



US00D613216S

(12) **United States Design Patent**  
**Ma**

(10) **Patent No.:** **US D613,216 S**

(45) **Date of Patent:** **\*\* Apr. 6, 2010**

(54) **PEDAL FOR AUTOMOBILES**

(76) Inventor: **Yongtao Ma**, Foshan (CN)

(\*\*) Term: **14 Years**

(21) Appl. No.: **29/313,649**

(22) Filed: **Jan. 29, 2009**

(30) **Foreign Application Priority Data**

Jul. 30, 2008 (CN) ..... 2008 3 0055256

(51) **LOC (9) Cl.** ..... **12-16**

(52) **U.S. Cl.** ..... **D12/174**

(58) **Field of Classification Search** ..... D12/125,  
D12/174, 400; 74/512, 560, 563; 280/259;  
403/257

See application file for complete search history.

(56) **References Cited**

**U.S. PATENT DOCUMENTS**

2,851,902 A \* 9/1958 Dishong ..... 74/560  
D221,215 S \* 7/1971 Hunckler ..... D12/174  
D250,814 S \* 1/1979 Dartnall ..... D12/174

D540,227 S \* 4/2007 Doucet ..... D12/174

\* cited by examiner

*Primary Examiner*—Susan Bennett Hattan

*Assistant Examiner*—Barbara B Lohr

(74) *Attorney, Agent, or Firm*—Timothy B. Kang; Mannava & Kang, P.C.

(57) **CLAIM**

The ornamental design for a pedal for automobiles, as shown and described.

**DESCRIPTION**

FIG. 1 is a front view of the pedal for automobiles in accordance with the present invention;

FIG. 2 is a rear view thereof;

FIG. 3 is a left side view thereof;

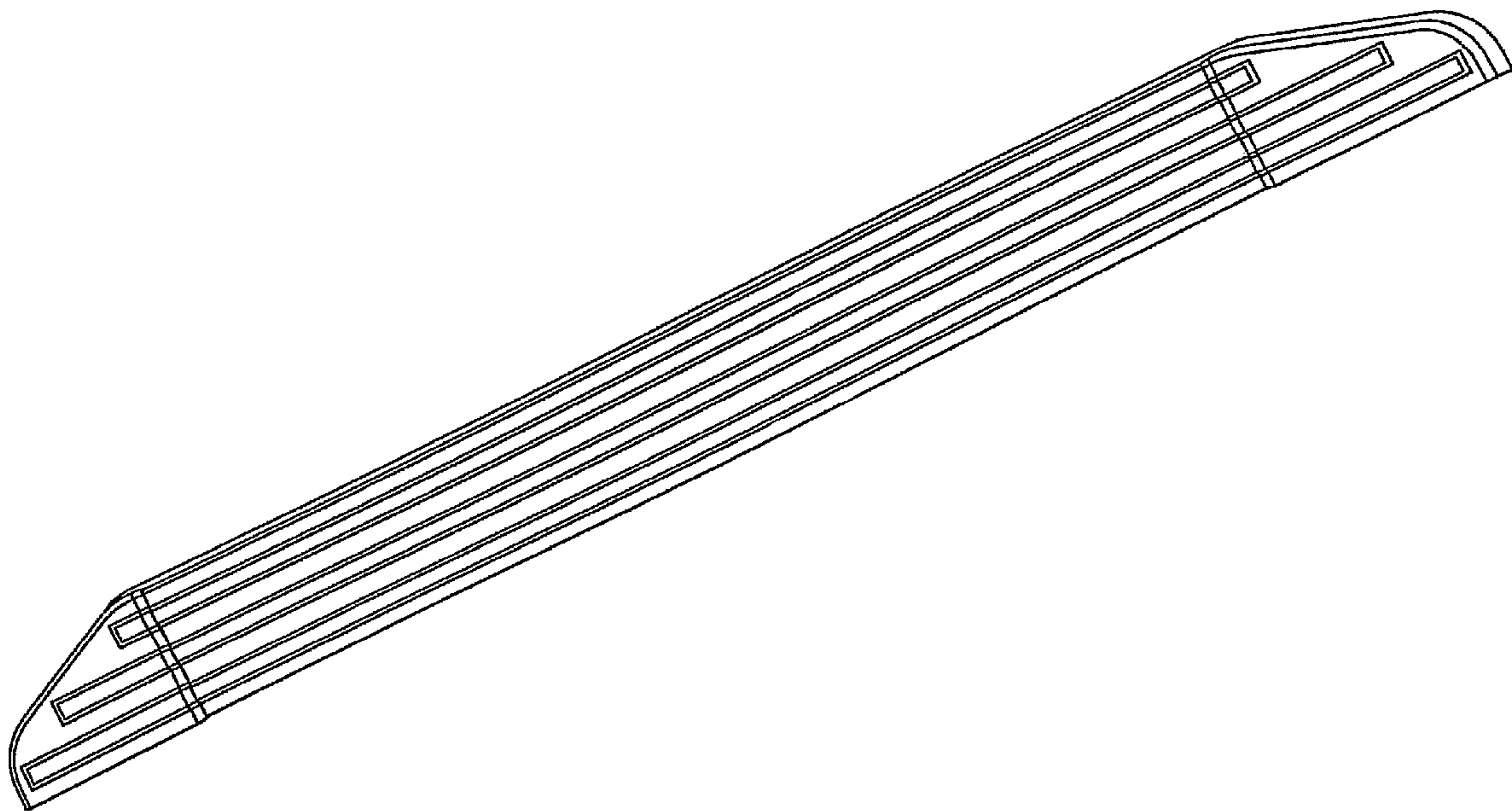
FIG. 4 is a right side view thereof;

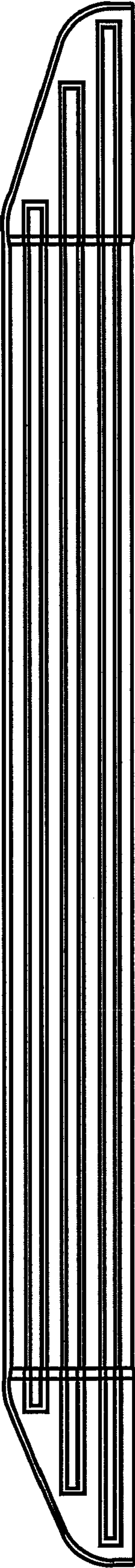
FIG. 5 is a top plan view thereof;

FIG. 6 is a bottom view thereof; and,

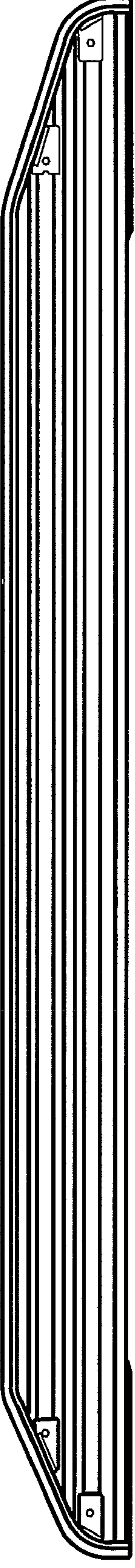
FIG. 7 is a perspective view thereof.

**1 Claim, 3 Drawing Sheets**

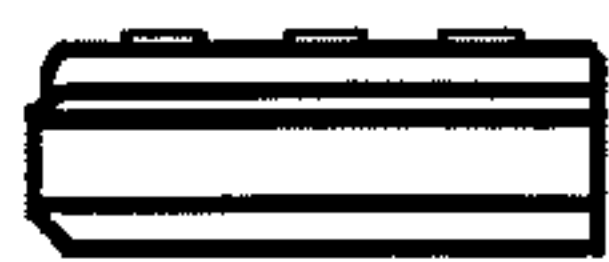




**FIG. 1**



**FIG. 2**



**FIG. 3**



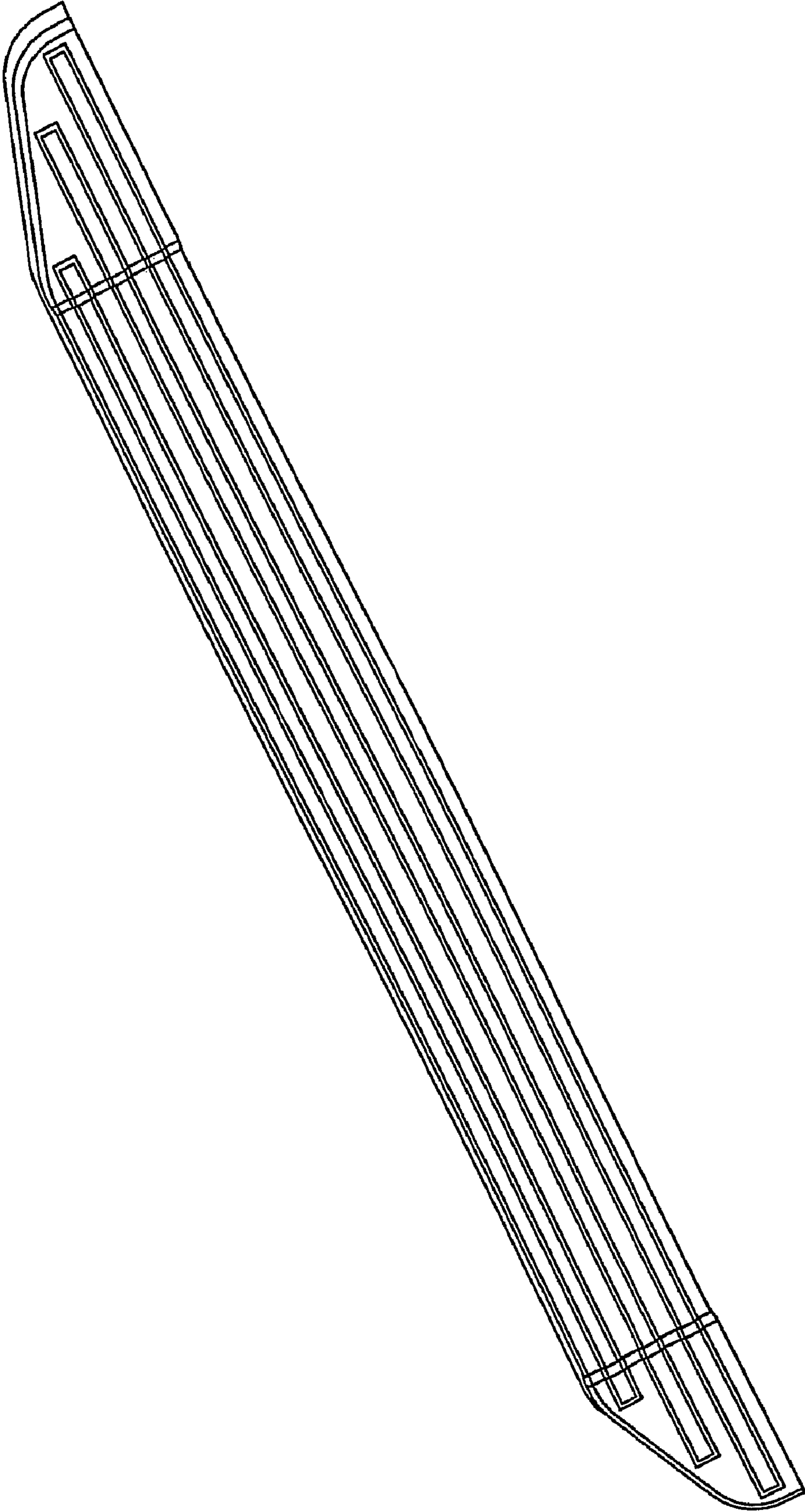
**FIG. 4**



**FIG. 5**



**FIG. 6**



**FIG. 7**