



US00D613204S

(12) **United States Design Patent**
Busch et al.

(10) **Patent No.:** **US D613,204 S**

(45) **Date of Patent:** **** Apr. 6, 2010**

(54) **VEHICLE**

(75) Inventors: **David B. Busch**, Fishers, IN (US);
Rollin Nothwehr, Holland, MI (US);
John E. Waters, Fortville, IN (US); **Lyle Shuey**, Noblesville, IN (US); **David Lauzun**, Noblesville, IN (US); **Sean Conway**, Royal Oaks, MI (US);
Hadrian Rori, Commerle, MI (US);
William Blair, Holand, MI (US); **John Clarke**, Farmington Hills, MI (US);
Peter LaDuke, Holand, MI (US);
Roland Knoepke, Zeeland, MI (US);
Michael Churchill, Toronto (CA);
Nathan Wills, Oceanside, CA (US);
Martin Goldman, South Lyon, MI (US);
Herbert Gruber, Rochester Hills, MI (US);
Michael Henderson, Greenville, SC (US); **Dale Frye**, West Olive, MI (US);
Timothy D. Bindon, Finnville, MI (US)

(73) Assignee: **Bright Automotive**, Anderson, IN (US)

(**) Term: **14 Years**

(21) Appl. No.: **29/335,696**

(22) Filed: **Apr. 20, 2009**

(51) **LOC (9) Cl.** **12-08**

(52) **U.S. Cl.** **D12/91**

(58) **Field of Classification Search** D12/86,
D12/90-92; 296/181.1, 181.5

See application file for complete search history.

(56) **References Cited**

U.S. PATENT DOCUMENTS

D249,495 S	9/1978	Wallace et al.
D256,348 S	8/1980	Galloway
D364,591 S	11/1995	Lewellen et al.
D410,415 S	6/1999	Schroeder
D411,141 S	6/1999	Gerisch et al.
D414,135 S	9/1999	Gerisch et al.

D433,363 S	11/2000	Gerisch et al.	
D445,068 S	7/2001	Martin et al.	
D499,987 S *	12/2004	Yanase et al.	D12/91
D501,428 S *	2/2005	Takahashi et al.	D12/91
D514,029 S	1/2006	Truong	
D605,557 S *	12/2009	Murakami	D12/91
D605,558 S *	12/2009	Koman et al.	D12/91

* cited by examiner

Primary Examiner—Melody N Brown

(74) *Attorney, Agent, or Firm*—Barnes & Thornburg LLP

(57) **CLAIM**

The ornamental design for a vehicle, as shown and described.

DESCRIPTION

FIG. 1 is a perspective view, taken from the front, left side, of an embodiment of the vehicle according to our design;

FIG. 2 is a front view thereof;

FIG. 3 is a left side view thereof;

FIG. 4 is a right side view thereof;

FIG. 5 is a top view thereof;

FIG. 6 is a rear view thereof;

FIG. 7 is a perspective view, taken from the front, left side, of a second embodiment of the vehicle according to our design;

FIG. 8 is a front view thereof;

FIG. 9 is a left side view thereof;

FIG. 10 is a right side view thereof;

FIG. 11 is a top view thereof; and,

FIG. 12 is a rear view thereof.

The broken lines for various components illustrated in FIGS. 7-12 are for illustrative purposes only and form no part of the claimed design.

Throughout the drawings, certain views are omitted. The omission of a particular view is intended to convey that the omitted view is plain and unornamented and forms no portion of the claimed design.

1 Claim, 12 Drawing Sheets

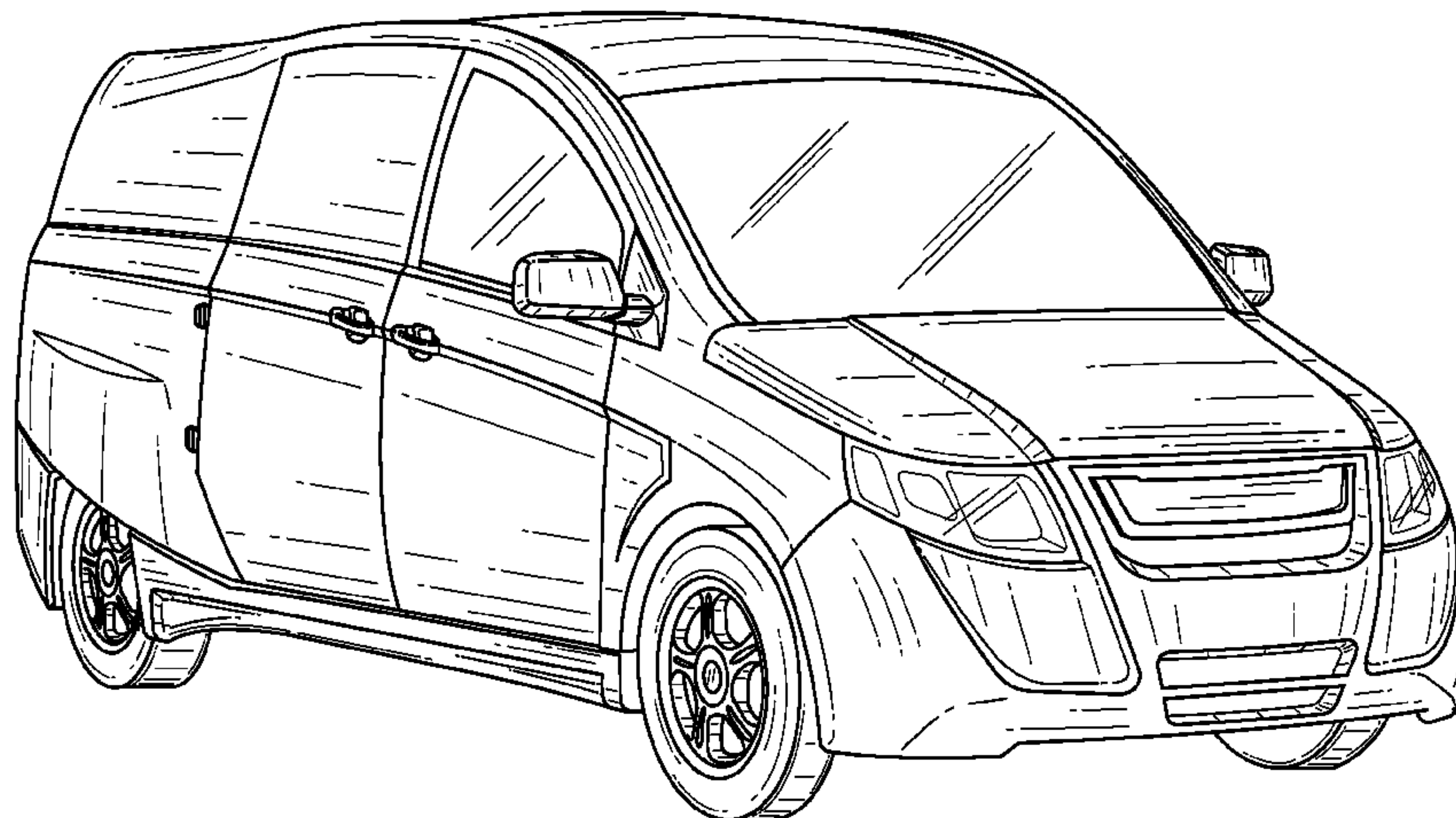

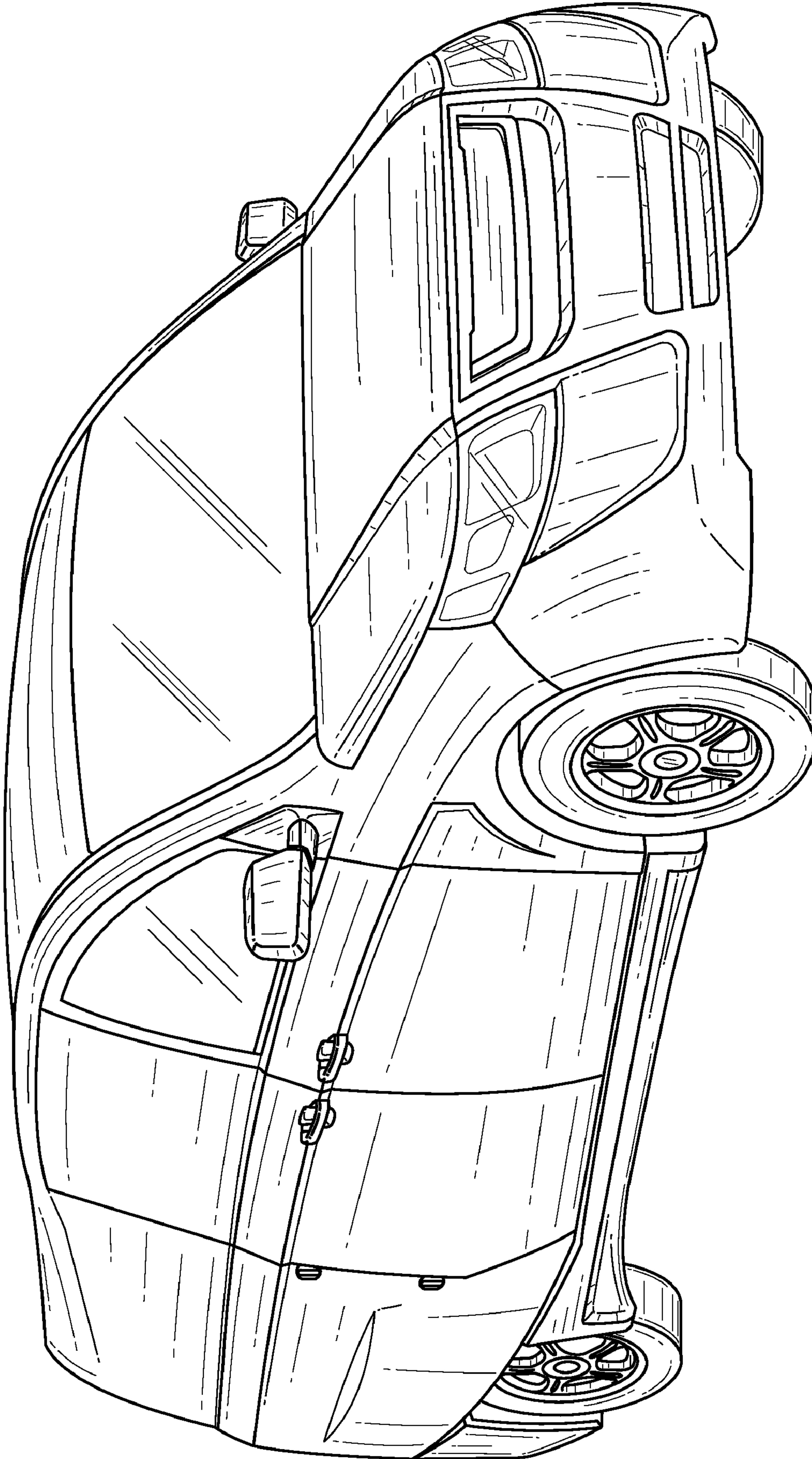

FIG. 1

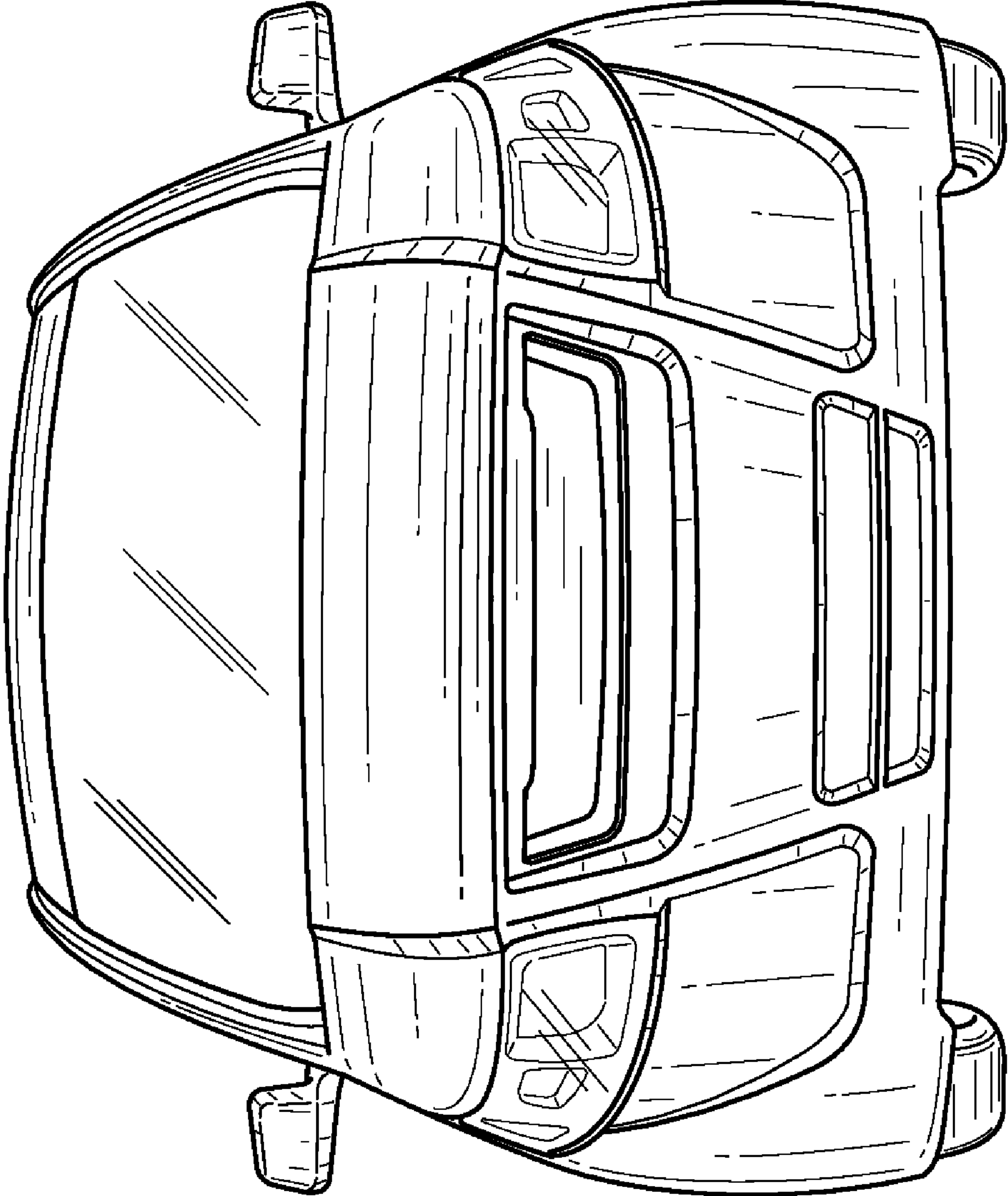

FIG. 2

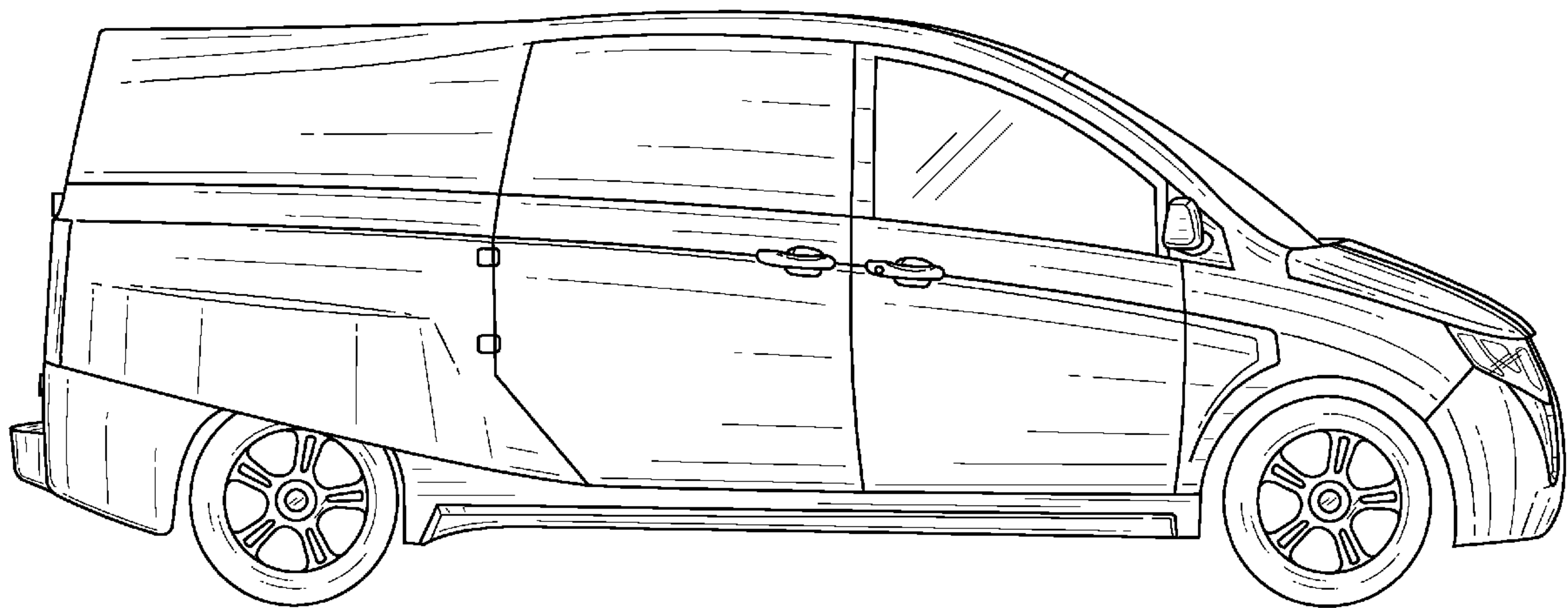

FIG. 3

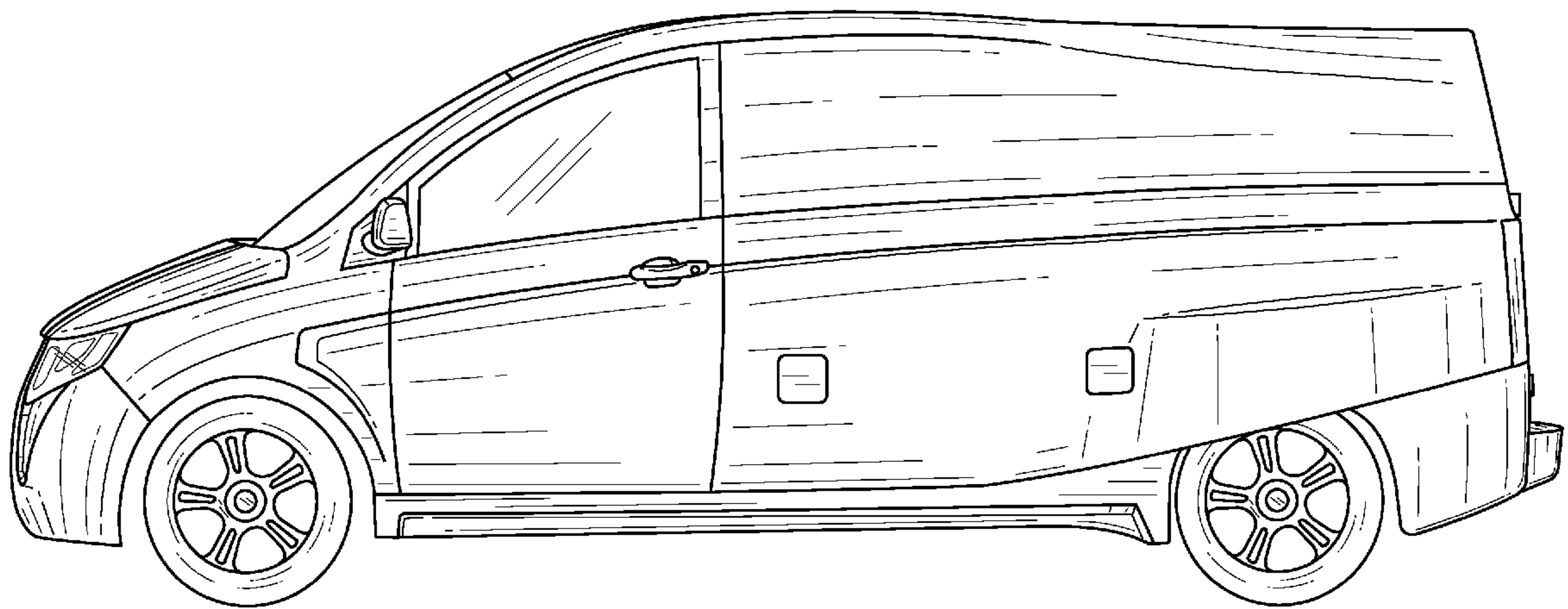

FIG. 4

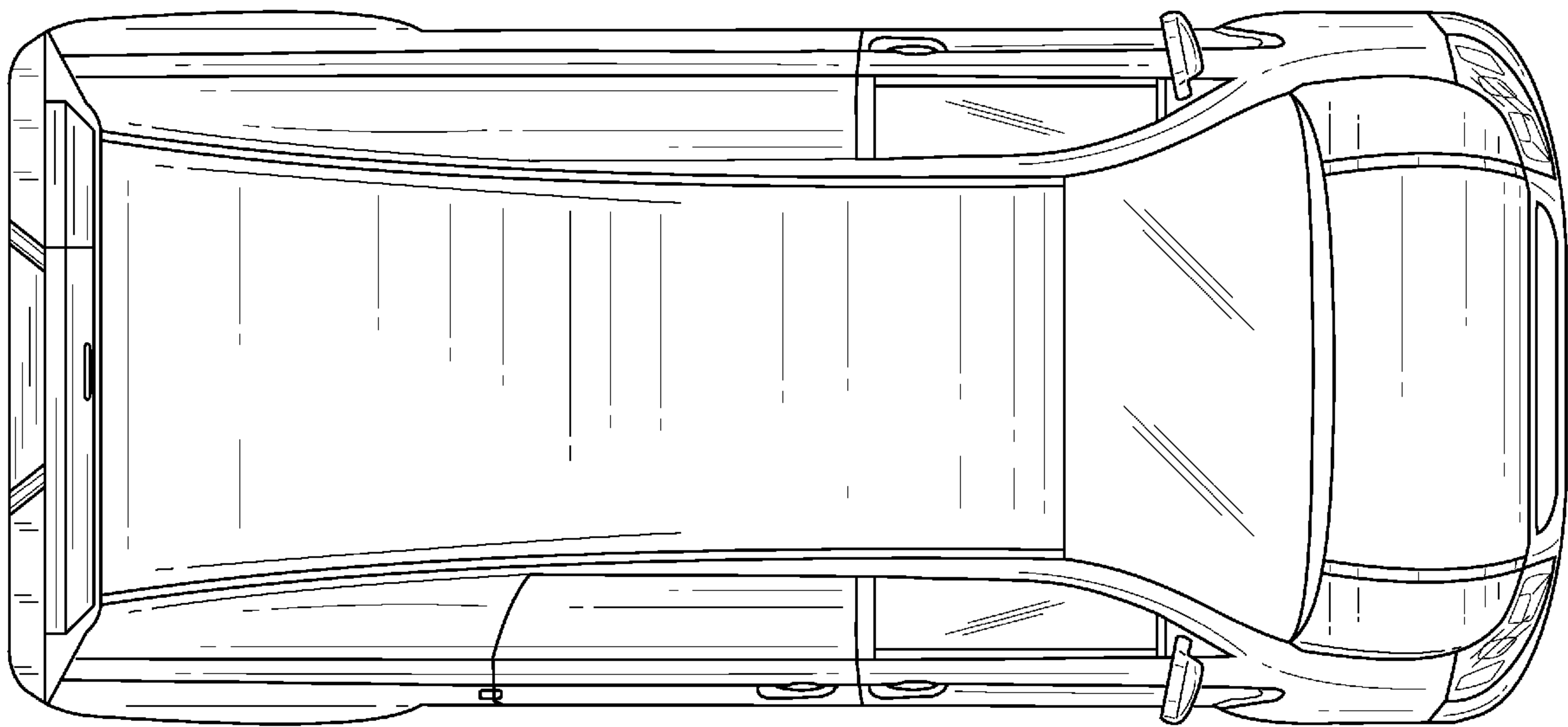

FIG. 5

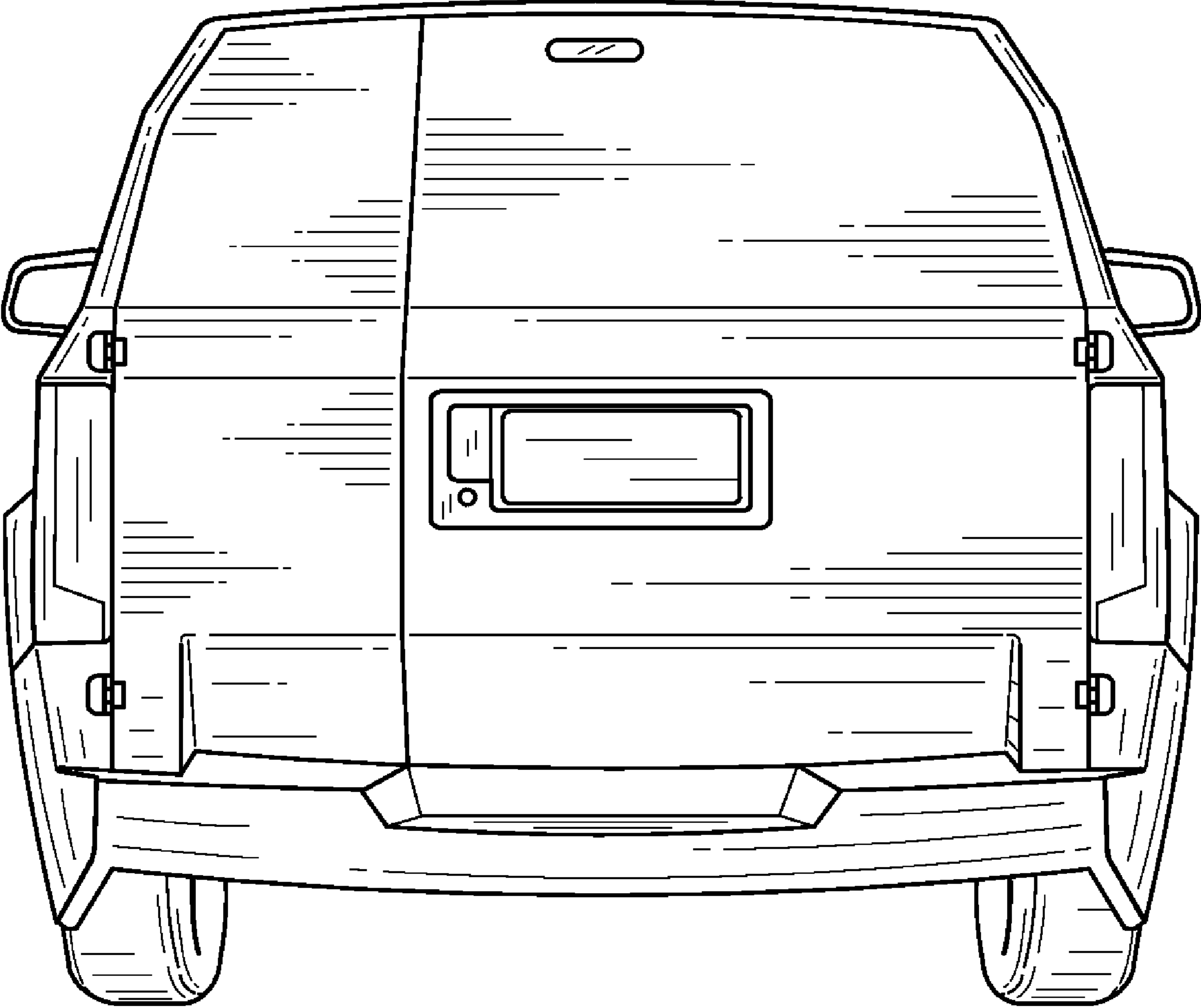

FIG. 6

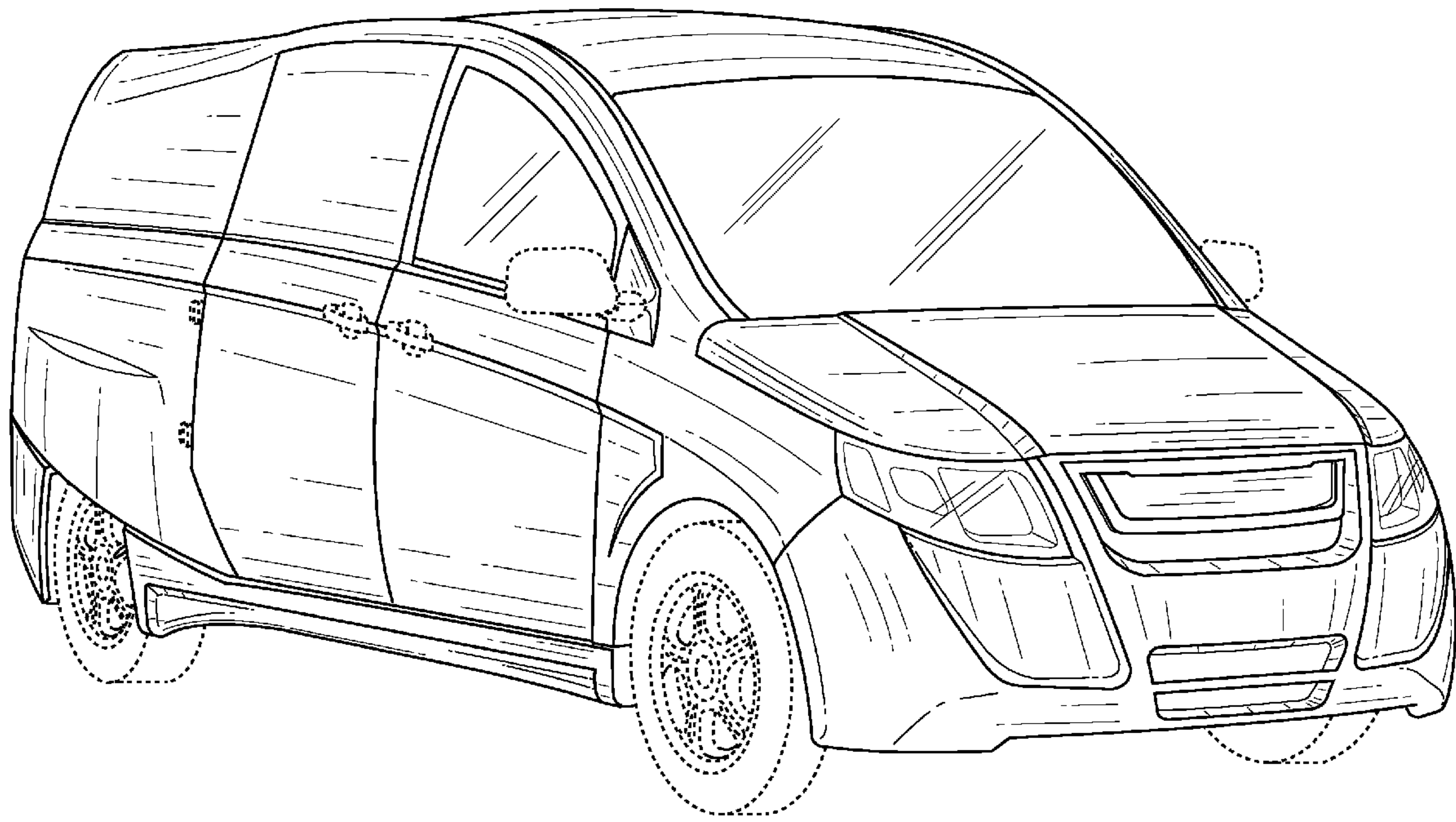

FIG. 7

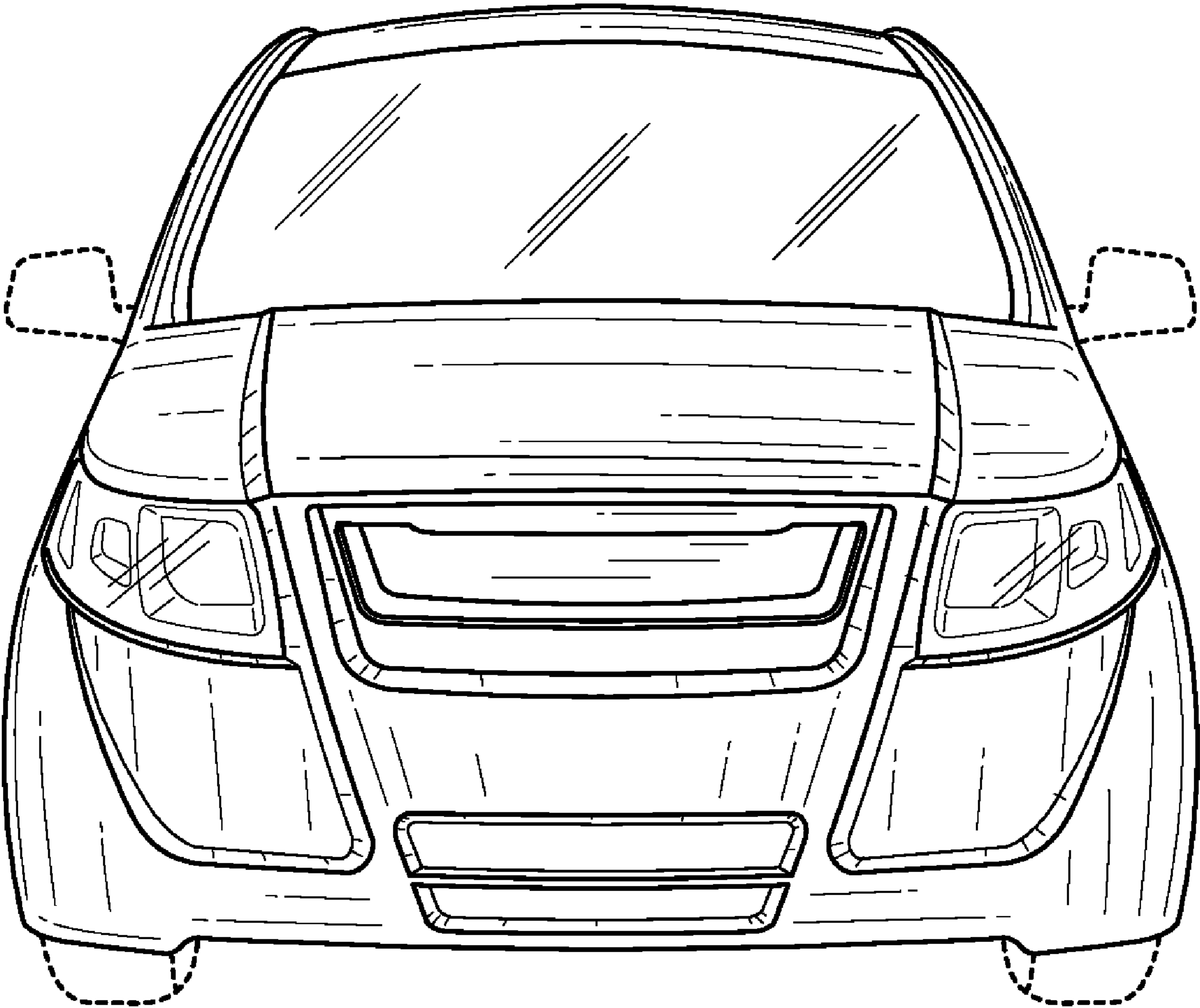

FIG. 8

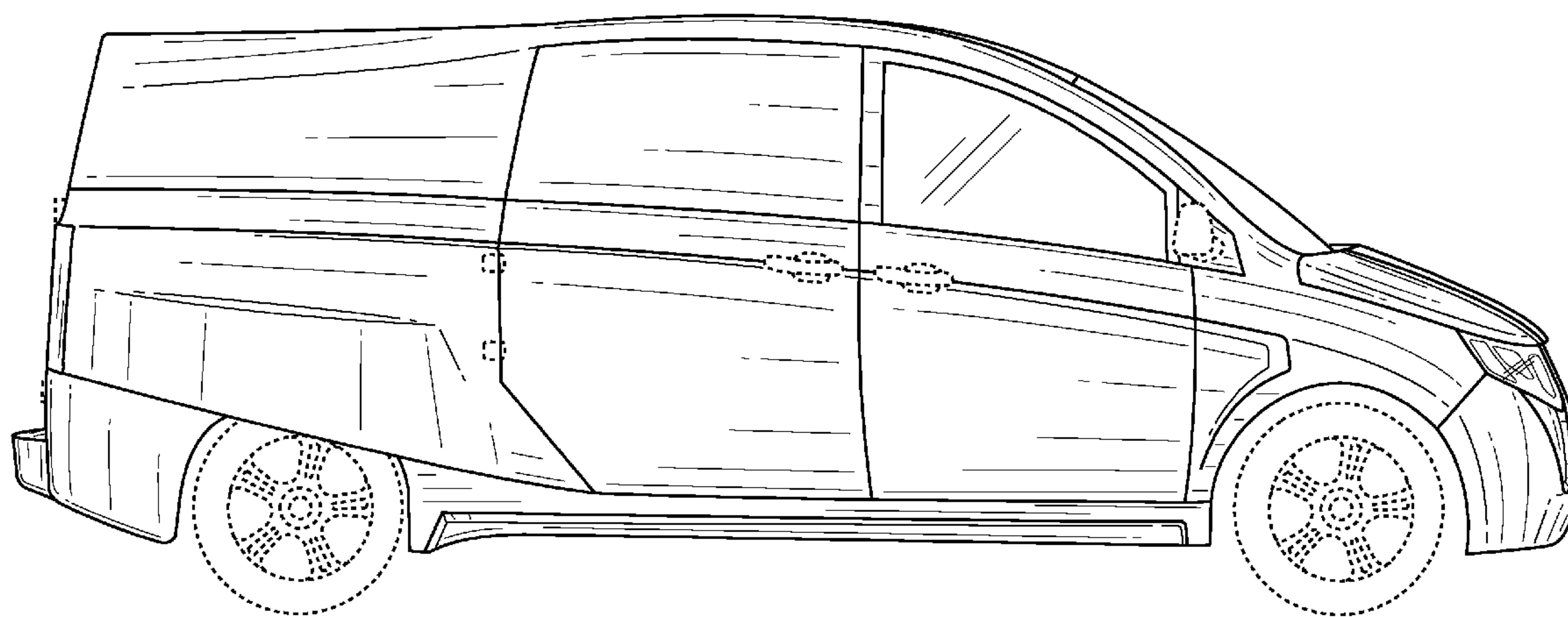

FIG. 9

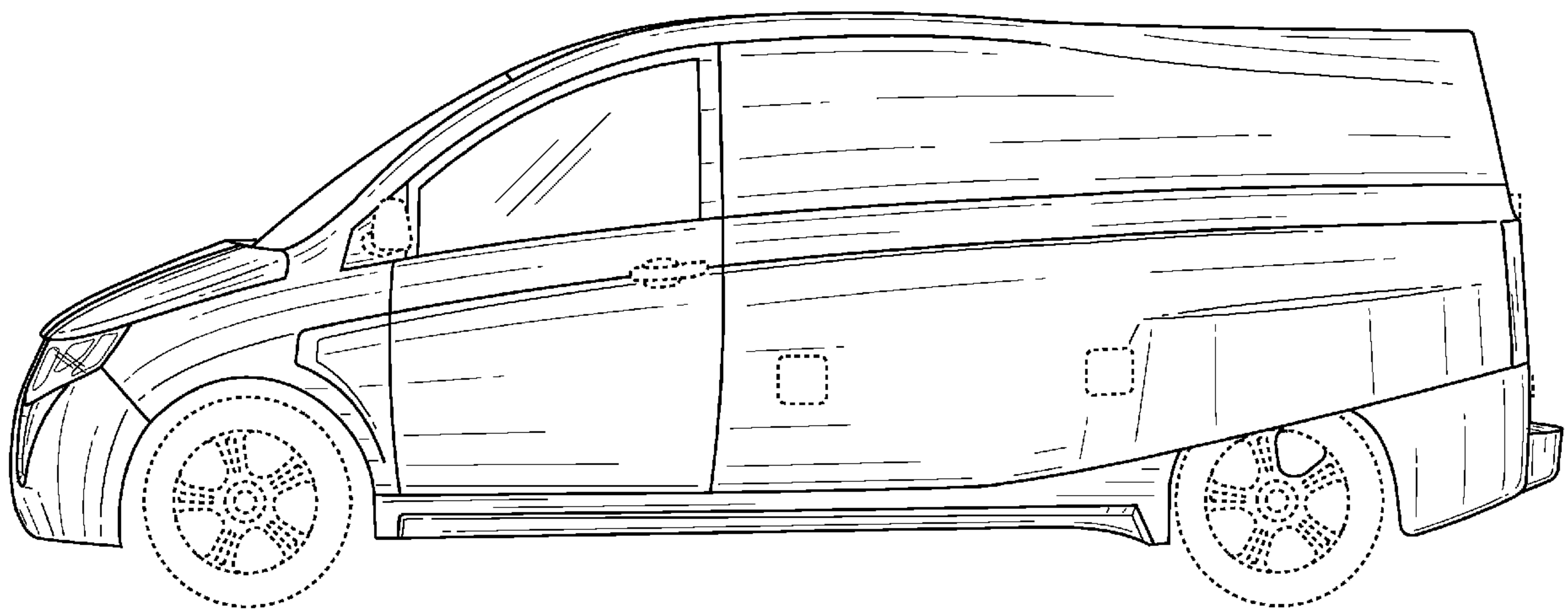

FIG. 10

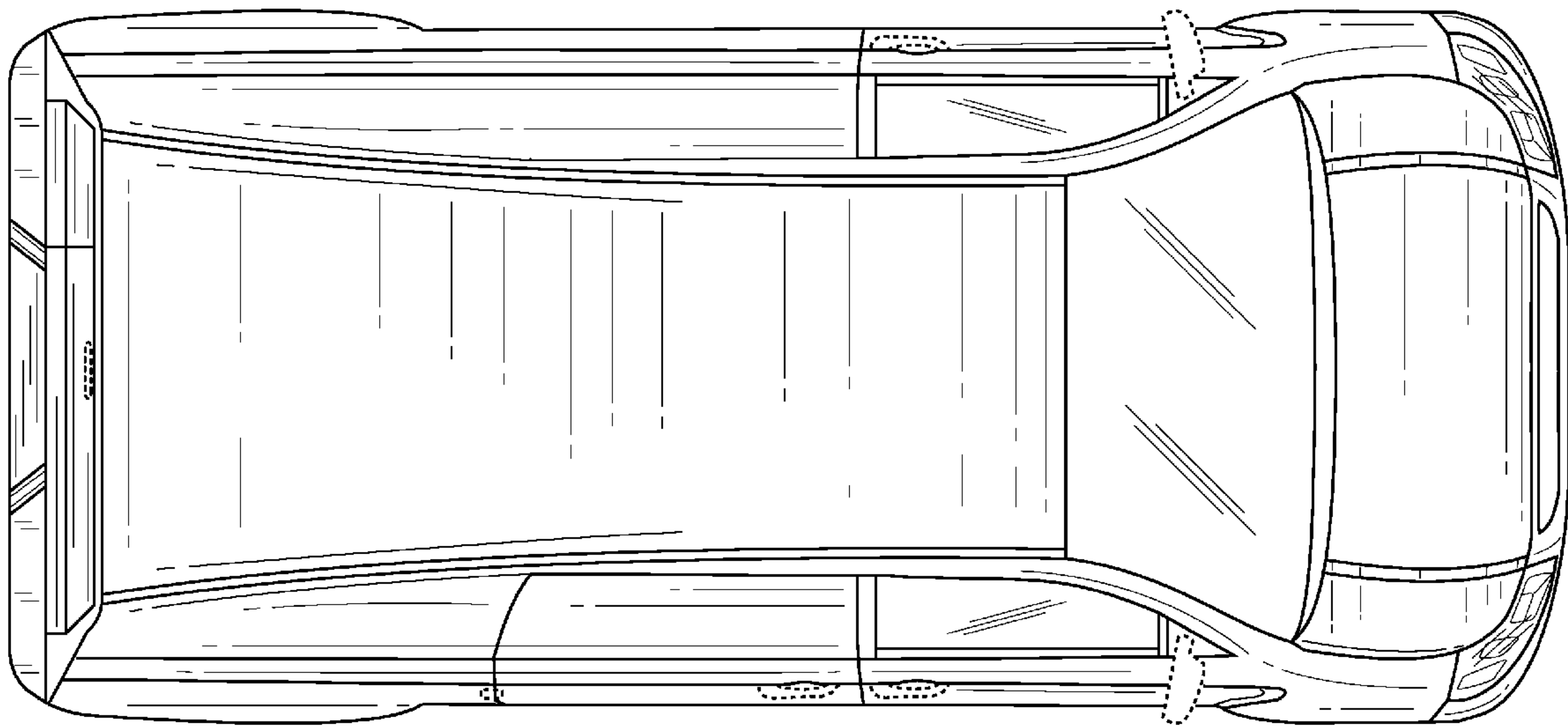

FIG. 11

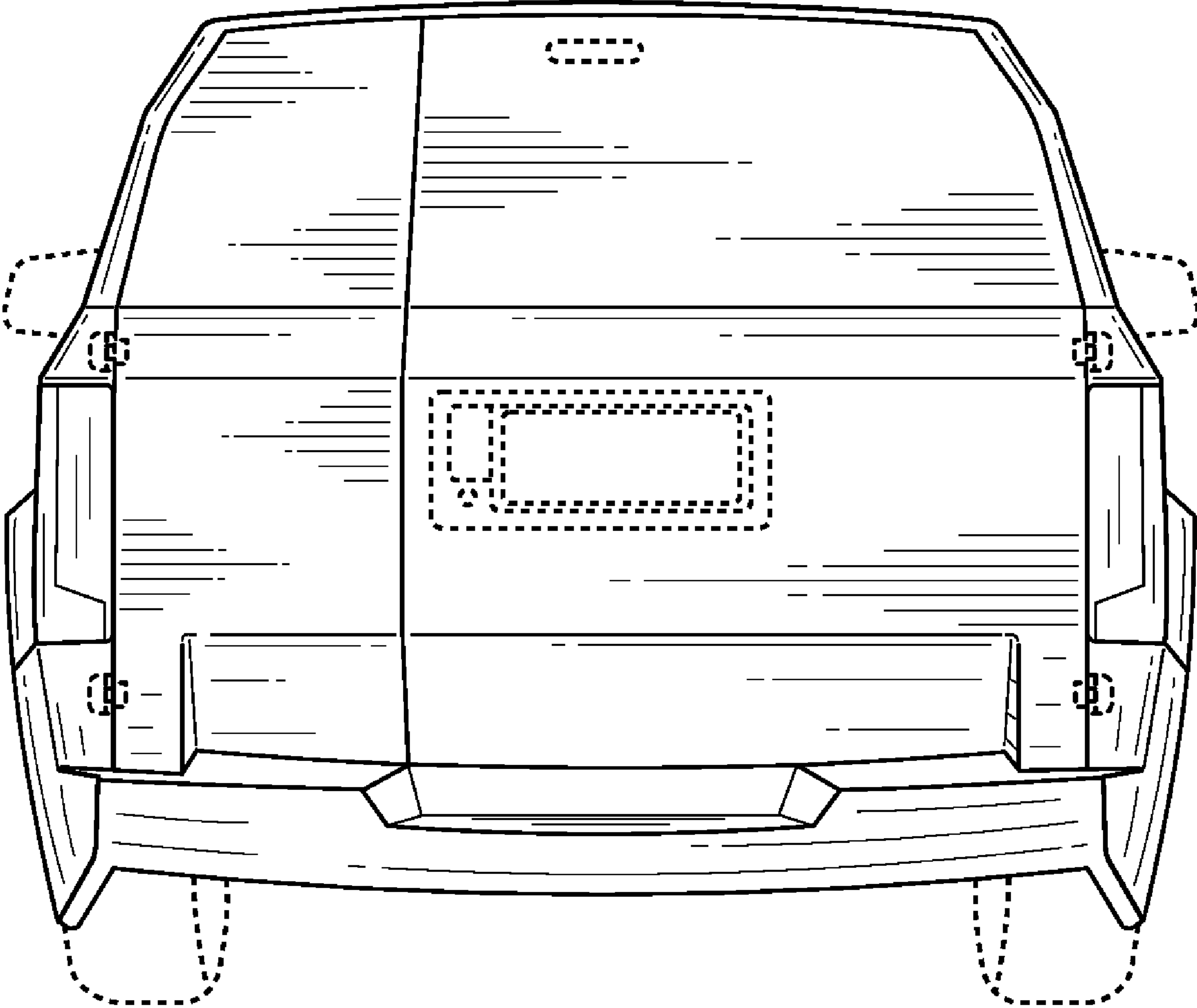

FIG. 12