



US00D613100S

(12) **United States Design Patent**
Chancey

(10) **Patent No.:** **US D613,100 S**
(45) **Date of Patent:** **** Apr. 6, 2010**

(54) **DRAWER DIVIDER DEVICE**

(75) Inventor: **Casey Chancey**, Circleville, OH (US)
(73) Assignee: **Health Care Logistics, Inc.**, Circleville, OH (US)
(**) Term: **14 Years**
(21) Appl. No.: **29/334,699**
(22) Filed: **Mar. 31, 2009**
(51) **LOC (9) Cl.** **06-06**
(52) **U.S. Cl.** **D6/510**
(58) **Field of Classification Search** D6/336,
D6/432, 436, 441, 445-446, 448, 462, 509-511;
D25/113, 155; 52/78, 177, 180, 302.4, 403.1,
52/590.1, 591.3, 591.4, 592.2; 156/258;
249/53 R, 159; 312/183; 404/41; 425/298;
472/90, 92
See application file for complete search history.

(56) **References Cited**
U.S. PATENT DOCUMENTS
1,823,285 A 9/1931 Petritsch

(Continued)

Primary Examiner—Caron Veynar
Assistant Examiner—Ricky Pham
(74) *Attorney, Agent, or Firm*—Standley Law Group LLP

(57) **CLAIM**

The ornamental design for a drawer divider device, as shown and described.

DESCRIPTION

FIG. 1 is a front perspective view of a single unit of the device;
FIG. 2 is a rear perspective view of the device from FIG. 1;
FIG. 3 is a top plan view of the device from FIG. 1;
FIG. 4 is a front elevational view of the device from FIG. 1;

FIG. 5 is a right side elevational view of the device from FIG. 1;
FIG. 6 is a rear elevational view of the device from FIG. 1;
FIG. 7 is a left side elevational view of the device from FIG. 1;
FIG. 8 is a bottom plan view of the device from FIG. 1;
FIG. 9 is a front perspective view showing a plurality of single units attached end to end;
FIG. 10 is a front perspective view showing the separation of units along the square wave seam;
FIG. 11 is a perspective view showing the assembly motion for assembling the units of FIG. 10 along their respective notches;
FIG. 12 is a perspective view showing the finished assembly of the units of FIG. 10 and 11;
FIG. 13 is a front perspective view showing the separation of units along a notch seam using a first motion;
FIG. 14 is a front perspective view showing the units from FIG. 13 once separated;
FIG. 15 is a perspective view showing the separation of units along a notch seam using a second motion;
FIG. 16 is a perspective view showing the units from FIG. 15 once separated;
FIG. 17 is a perspective view showing an assembly motion for assembling the unit from FIG. 14 into a notch seam of another piece;
FIG. 18 is a perspective view showing the completed assembly from FIG. 17;
FIG. 19 is a perspective view showing the completed assembly of a plurality of different pieces;
FIG. 20 is a perspective view showing the re-connection of a square wave seam making an angle greater than 90 degrees; and,
FIG. 21 is a perspective view showing the re-connection of a square wave seam making an angle less than 90 degrees.

1 Claim, 12 Drawing Sheets

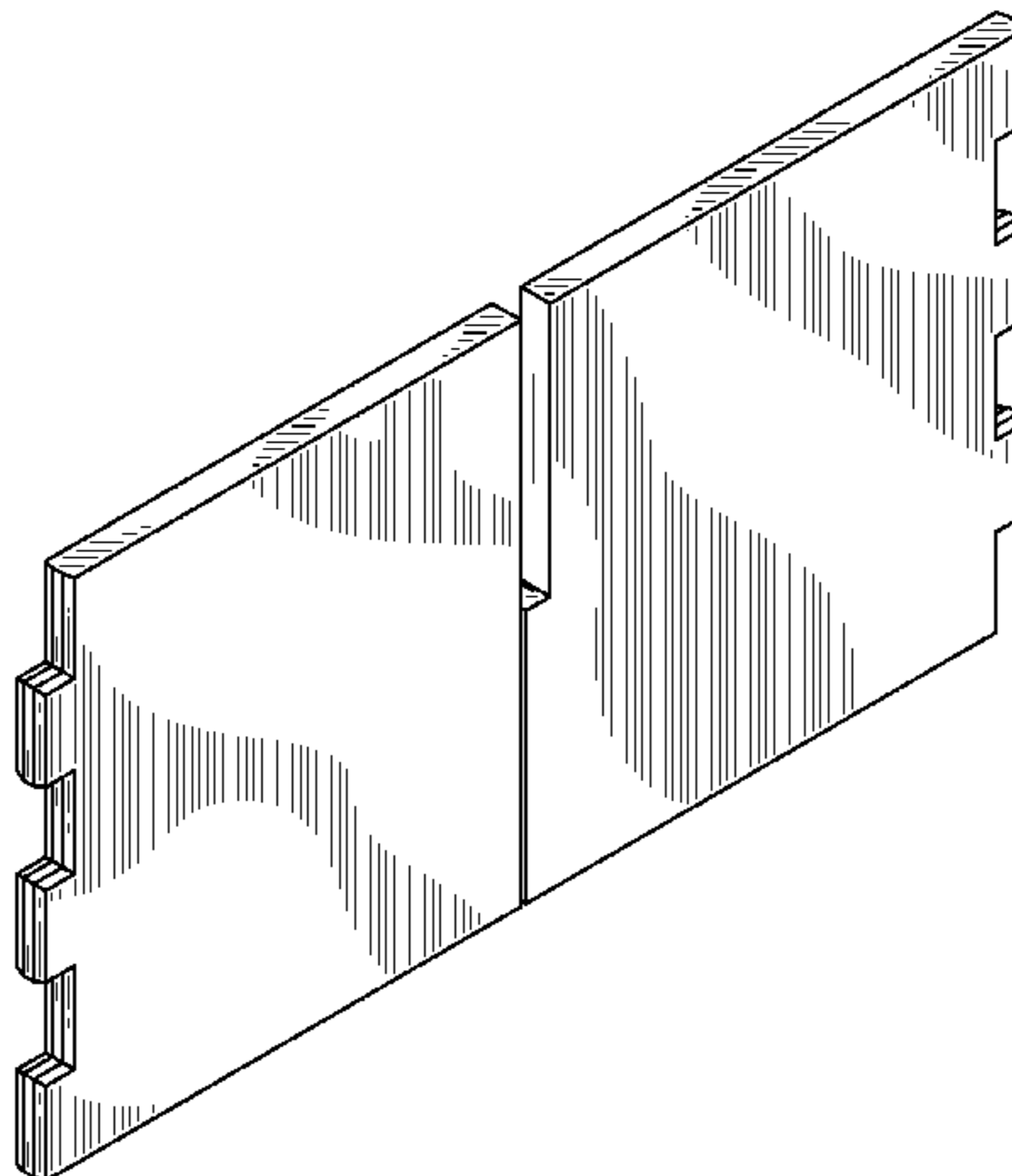

US D613,100 S

Page 2

U.S. PATENT DOCUMENTS

2,981,997	A *	5/1961	Painter	249/159	5,950,378	A *	9/1999	Council et al.	52/177
2,999,431	A *	9/1961	Mitchell	472/92	D417,986	S	12/1999	Quinn		
3,909,996	A *	10/1975	Ettlinger et al.	52/177	6,027,599	A *	2/2000	Wang	156/258
3,954,202	A	5/1976	Petrick			6,073,794	A	6/2000	Bidot		
4,005,943	A *	2/1977	Devenish et al.	404/41	D472,652	S *	4/2003	Stegner et al.	D25/155
4,018,025	A *	4/1977	Collette	52/302.4	6,584,747	B2 *	7/2003	Kettler et al.	52/592.2
4,030,729	A *	6/1977	Nathaniel	472/90	6,588,167	B2 *	7/2003	Chang	52/590.1
4,156,516	A *	5/1979	Oliver	249/53 R	D483,499	S *	12/2003	Payne	D25/113
4,226,064	A *	10/1980	Kraayenhof	52/180	6,820,386	B2 *	11/2004	Kappeli et al.	52/591.4
4,287,693	A *	9/1981	Collette	52/177	6,871,921	B2	3/2005	Ernst		
4,705,168	A	11/1987	Ward			7,210,920	B2 *	5/2007	Kolz	425/298
4,850,739	A *	7/1989	Gargollo	404/41	2006/0250053	A1 *	11/2006	Arney	312/183
5,257,693	A	11/1993	Kwasniak			2007/0261317	A1 *	11/2007	Moller, Jr.	52/78
5,791,114	A *	8/1998	Mandel	52/591.3	2009/0031658	A1 *	2/2009	Moller et al.	52/403.1

* cited by examiner

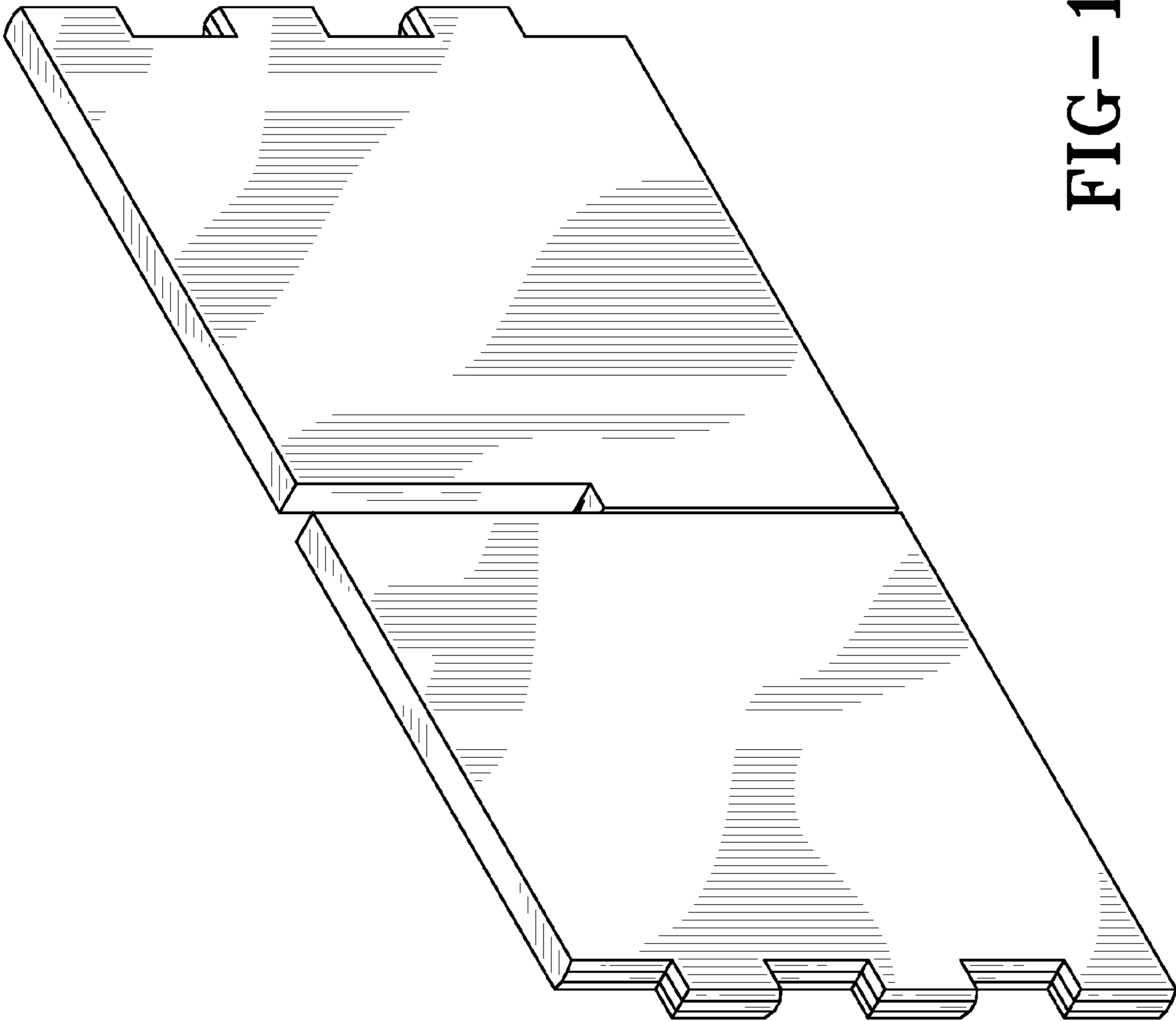

FIG-1

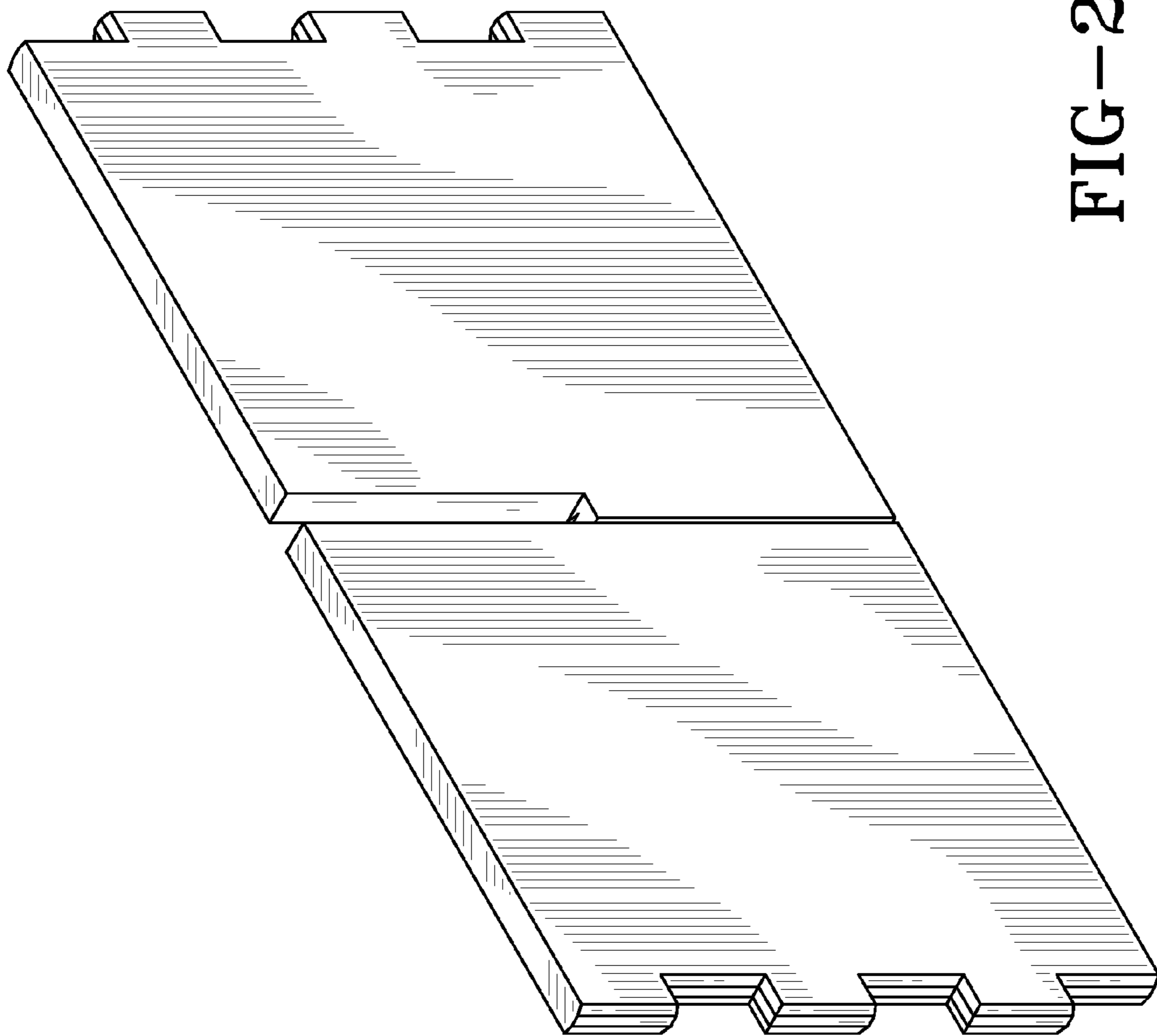

FIG-2



FIG-3

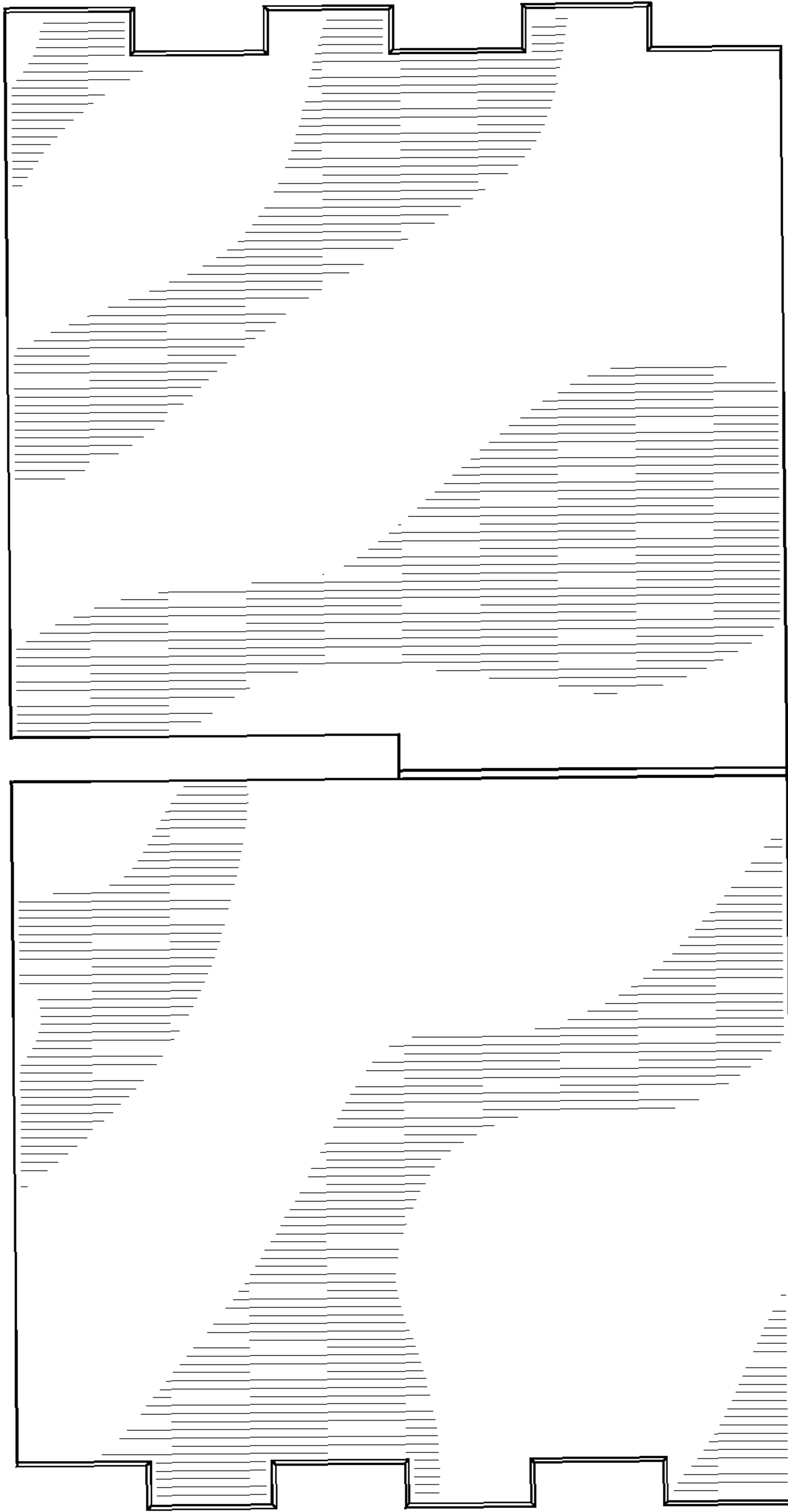

FIG-4



FIG-5



FIG-7



FIG-6



FIG-8

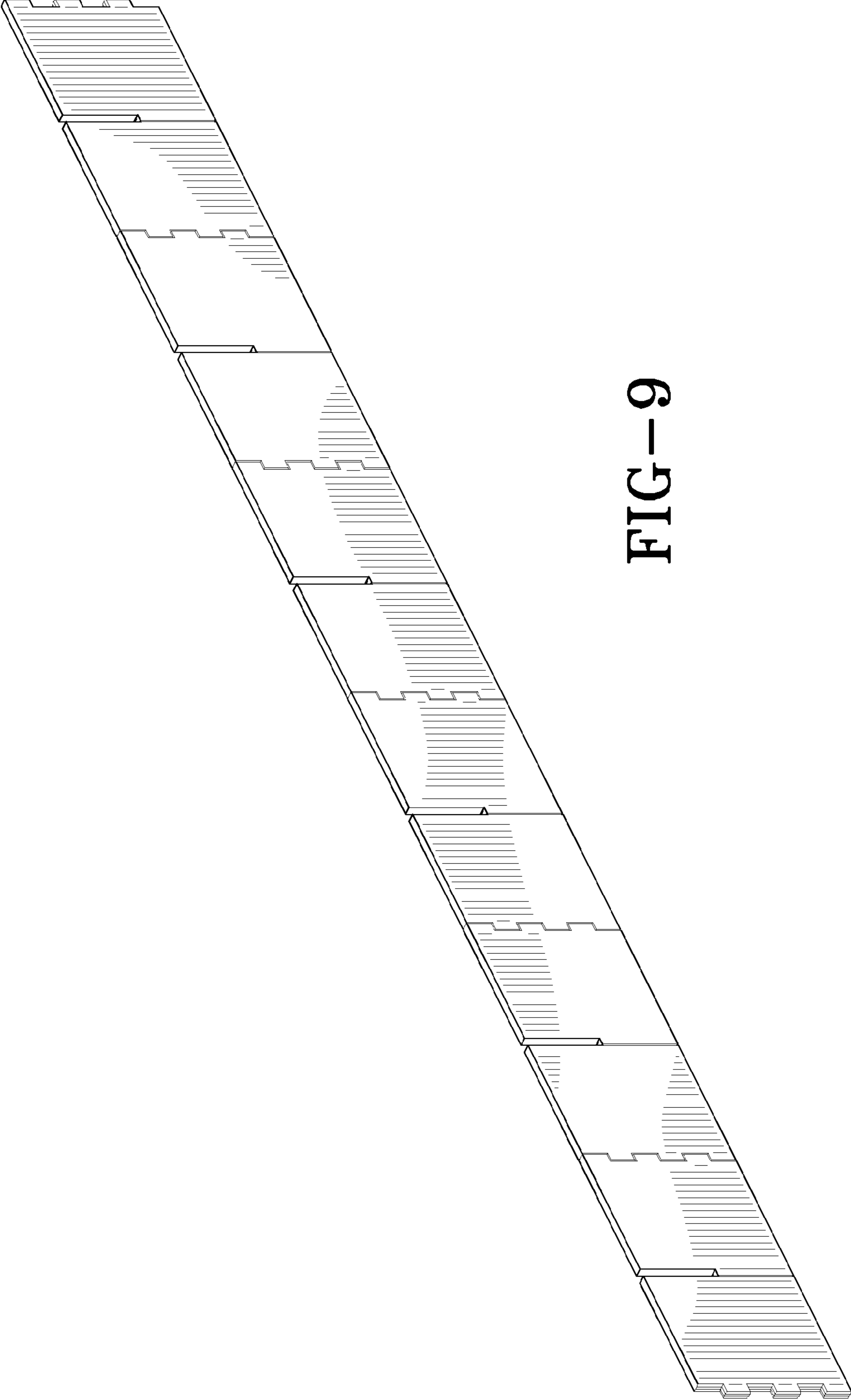

FIG-9

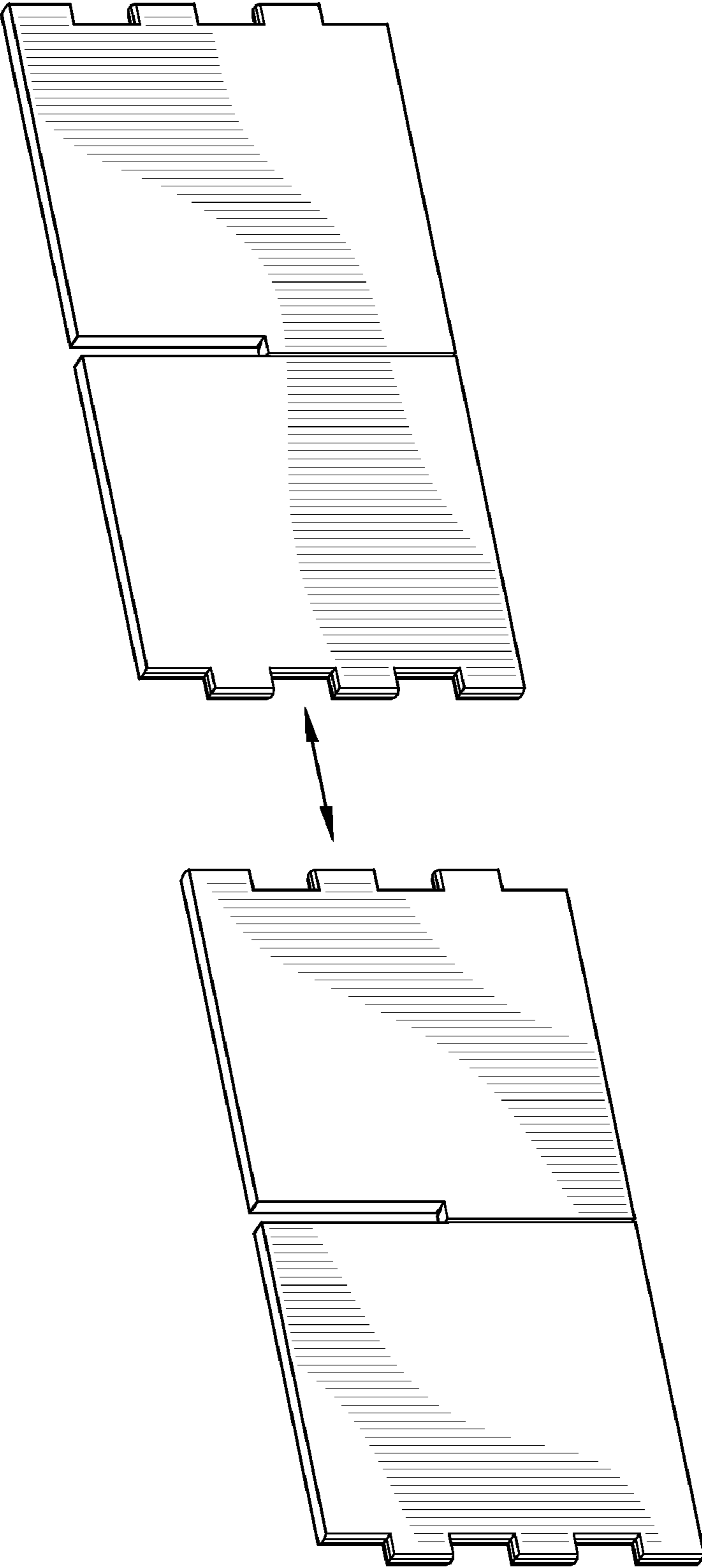

FIG--10

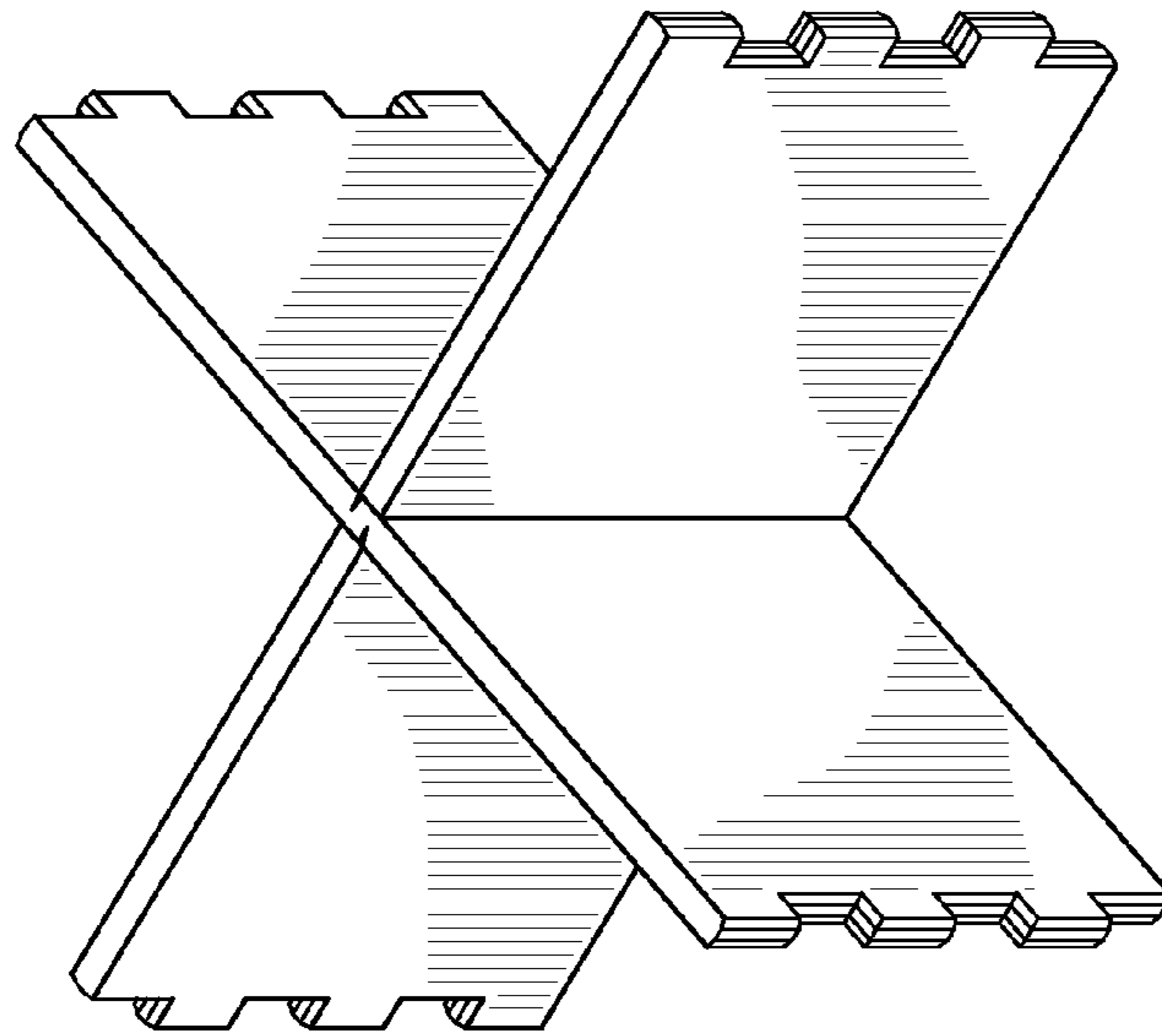

FIG-12

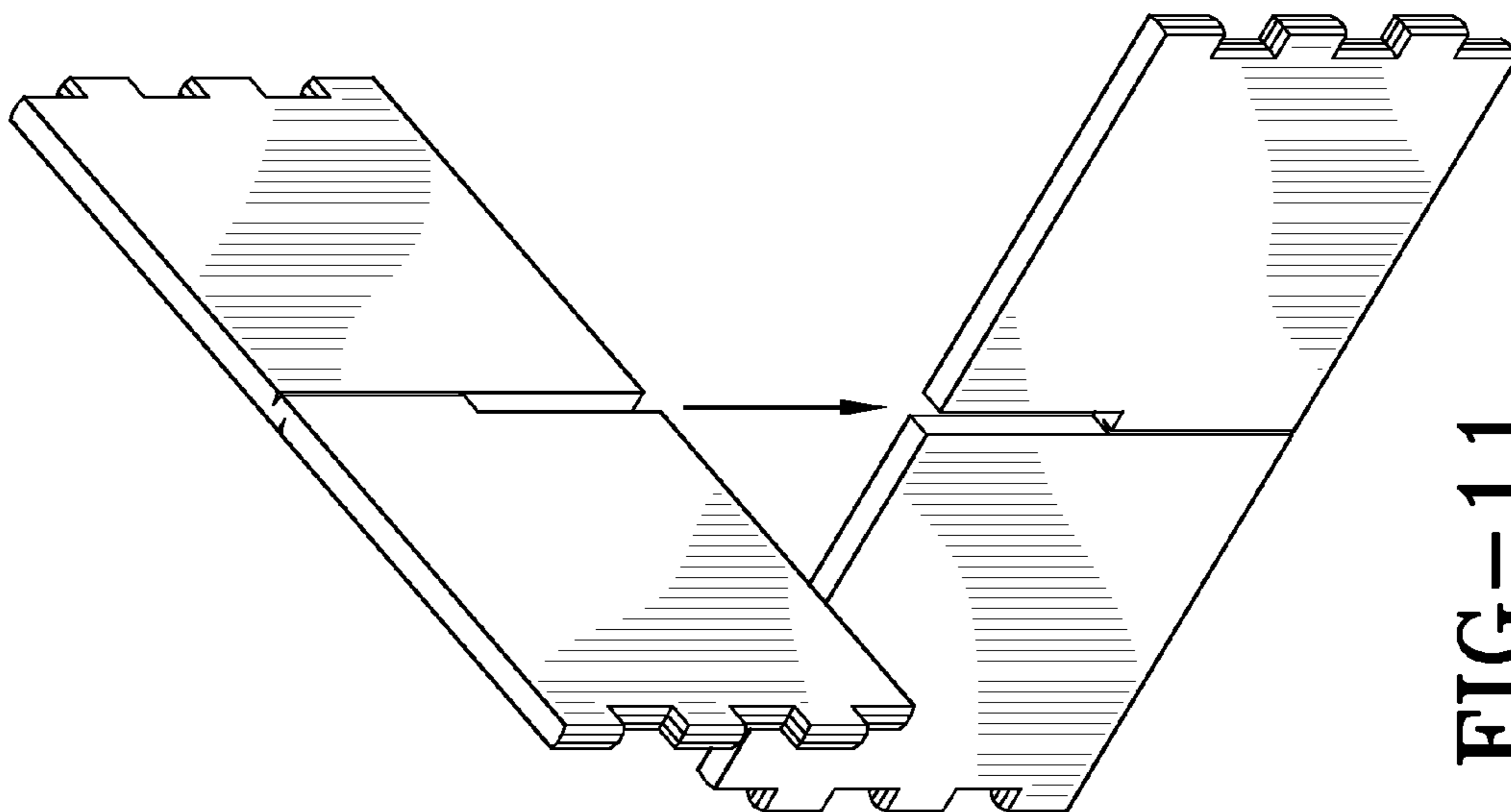

FIG-11

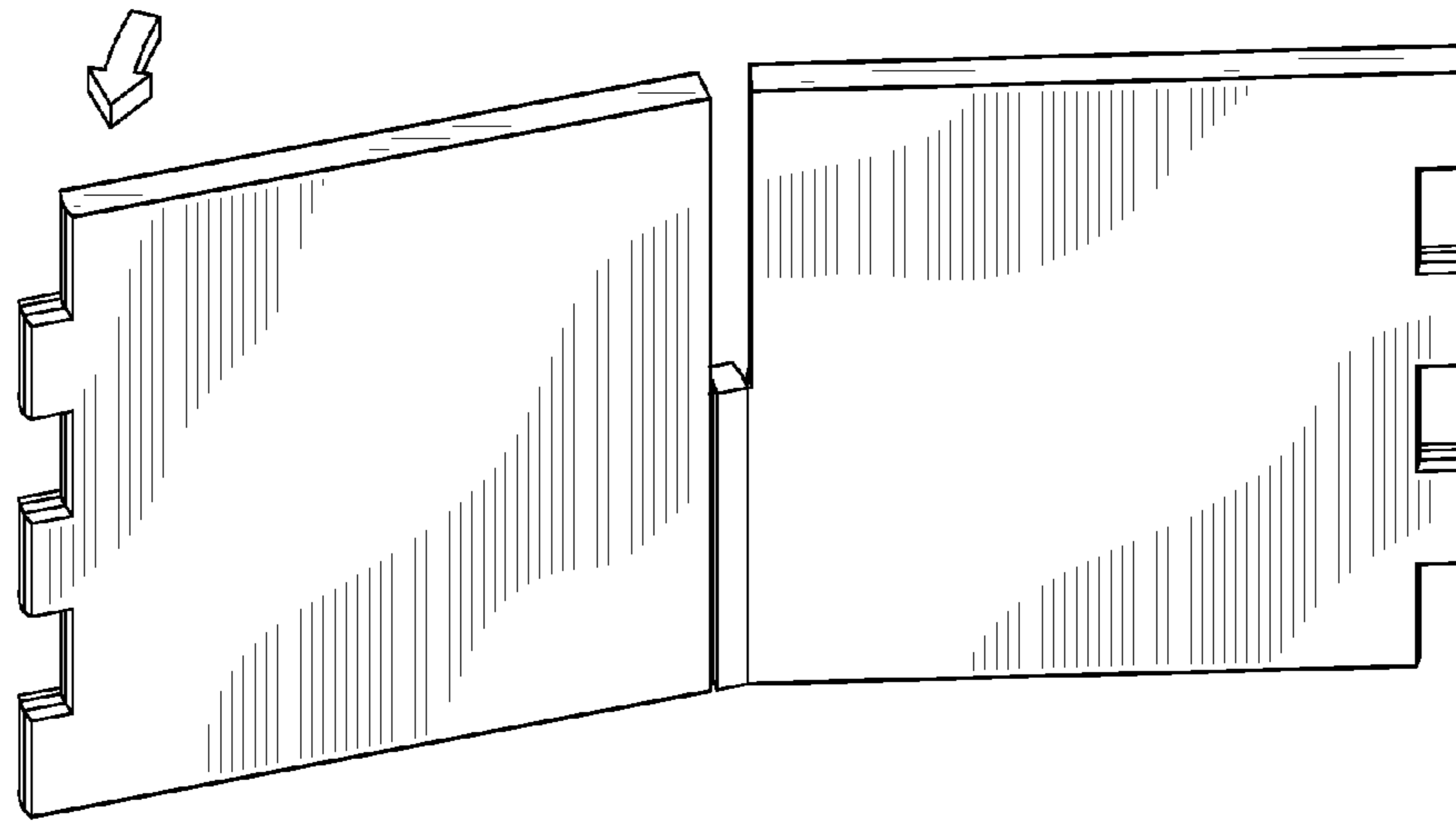

FIG-13

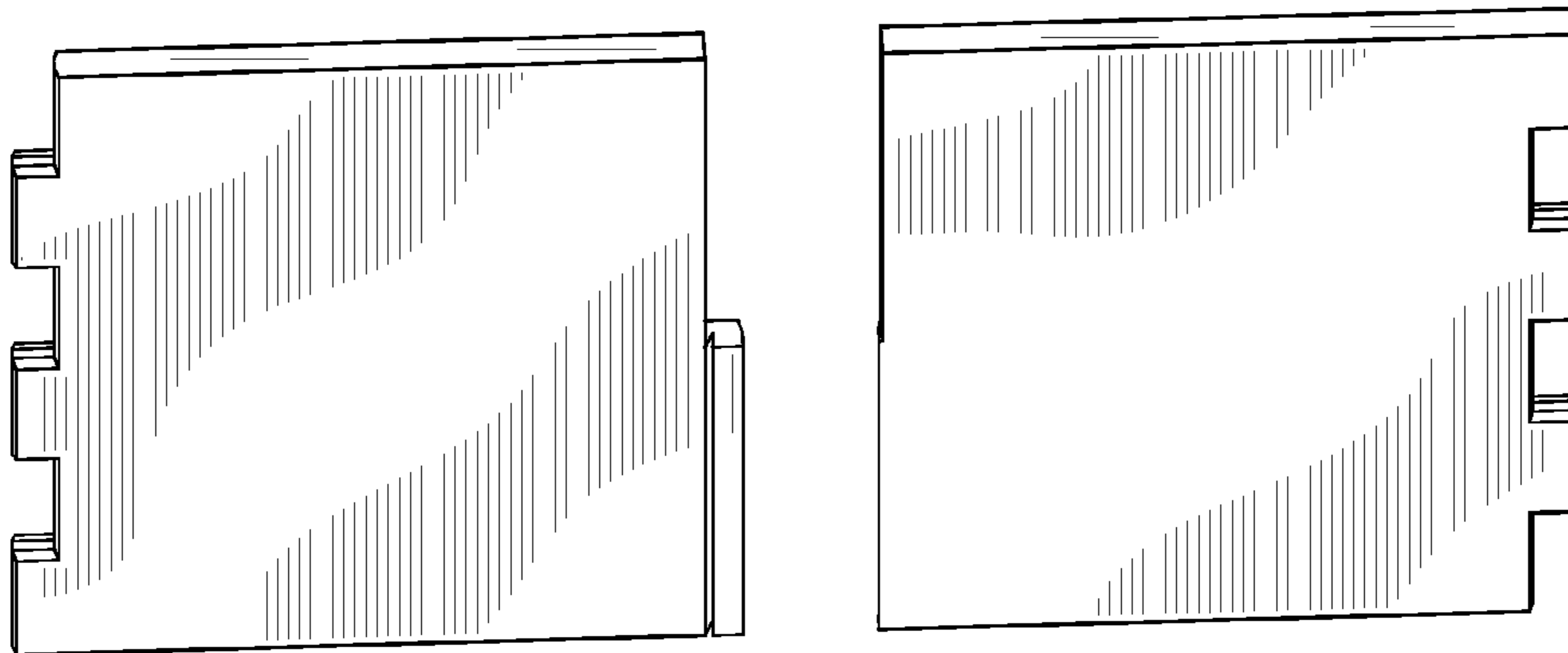

FIG-14

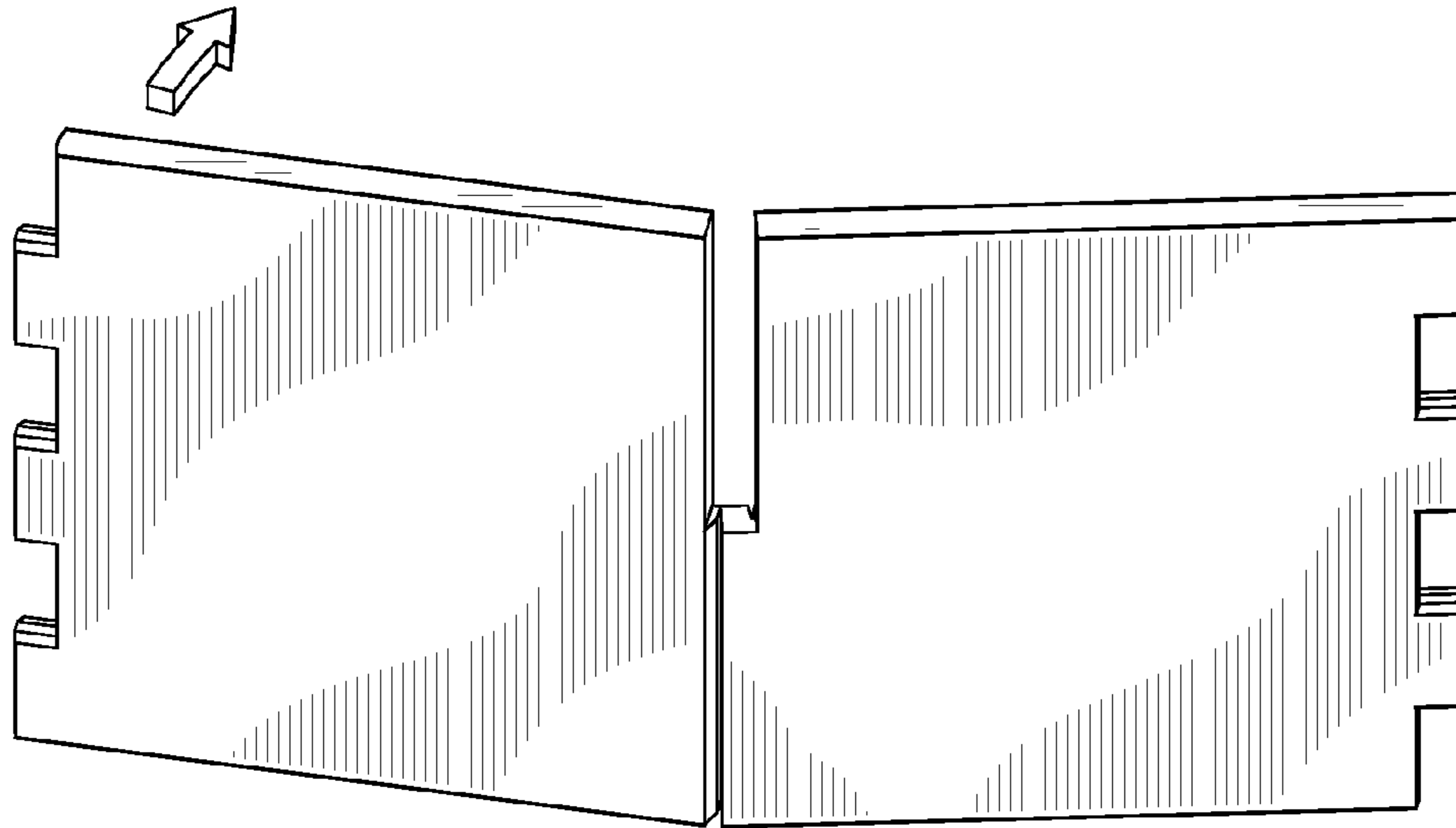

FIG-15

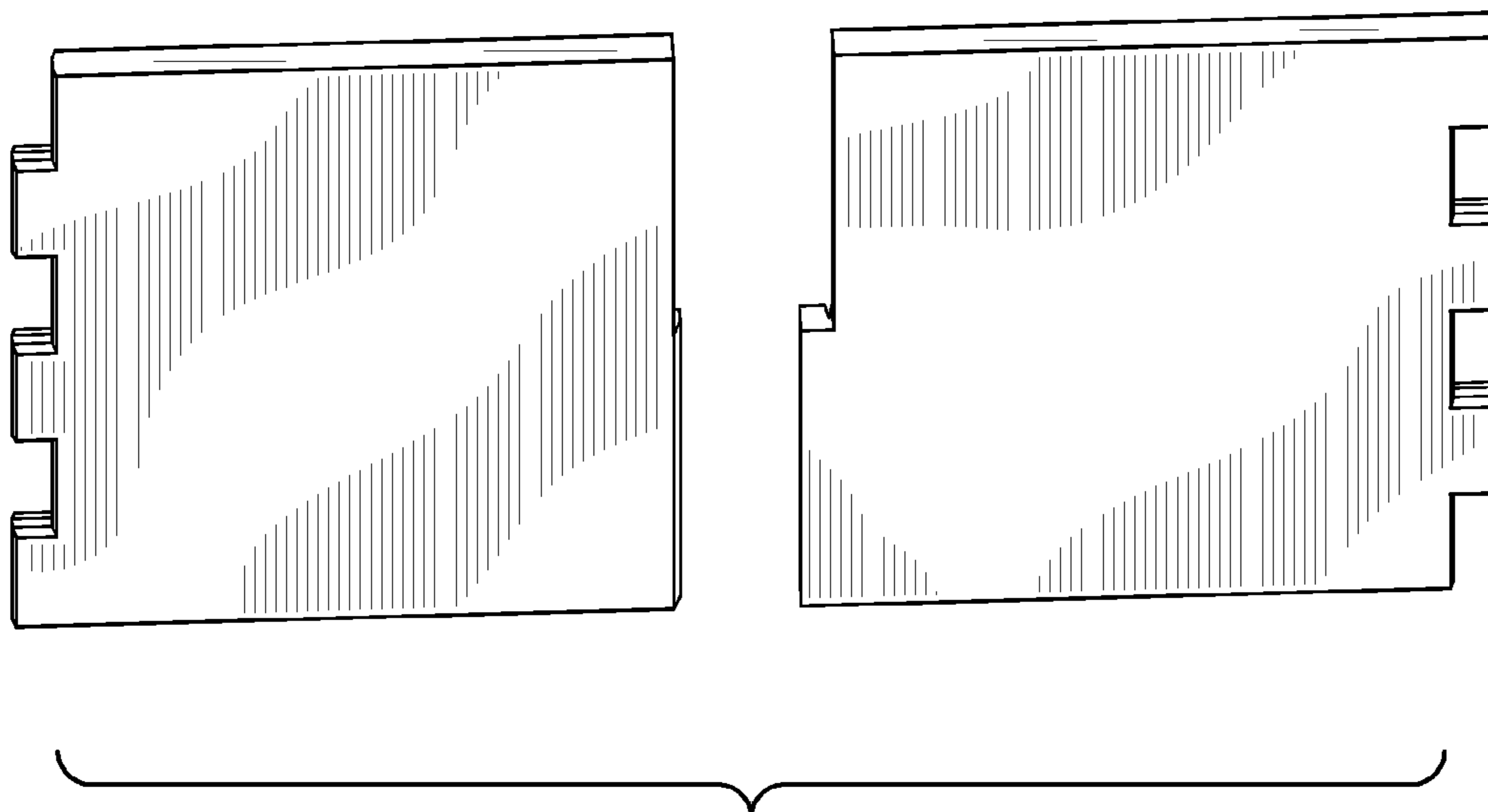

FIG-16

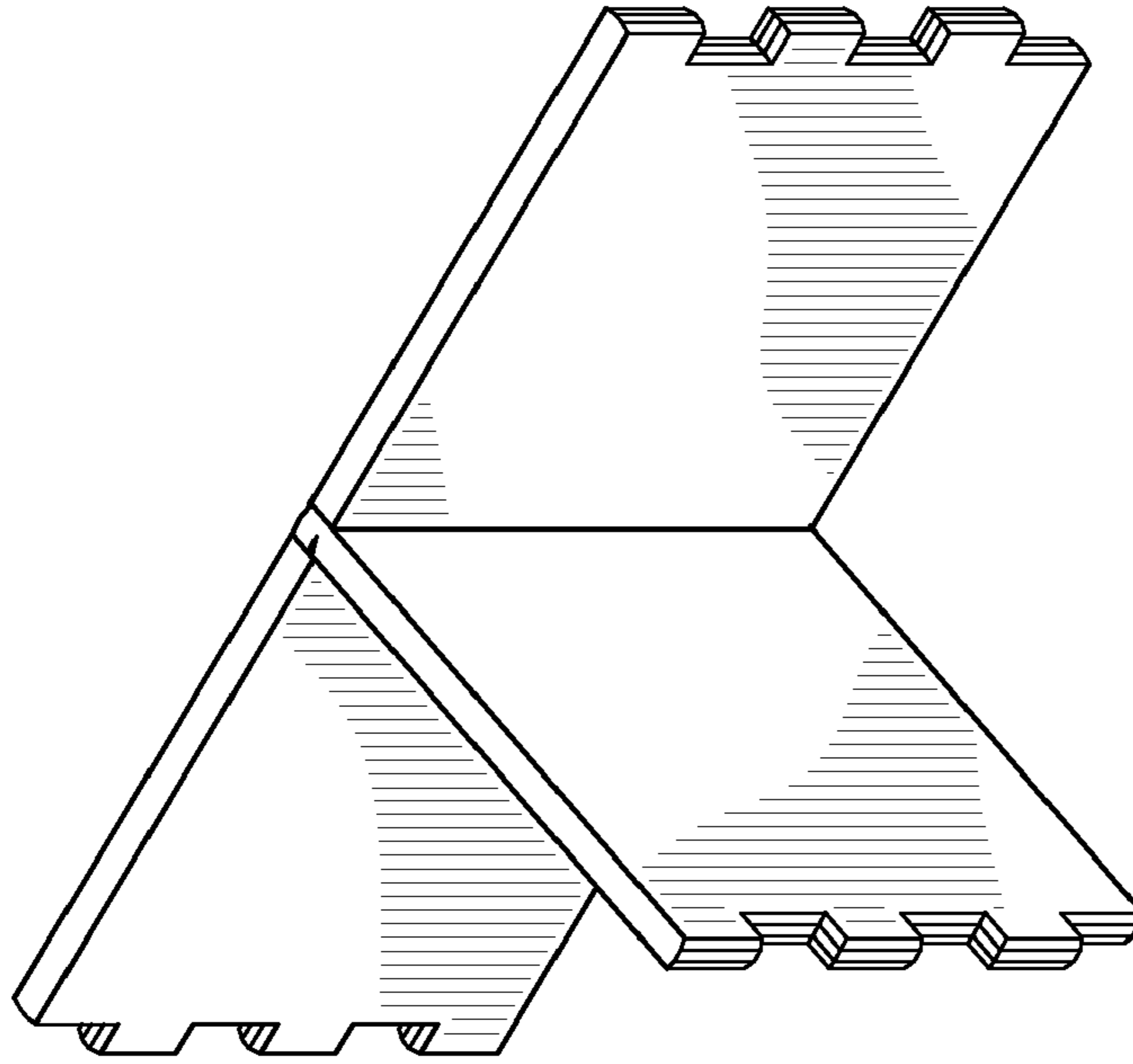

FIG-18

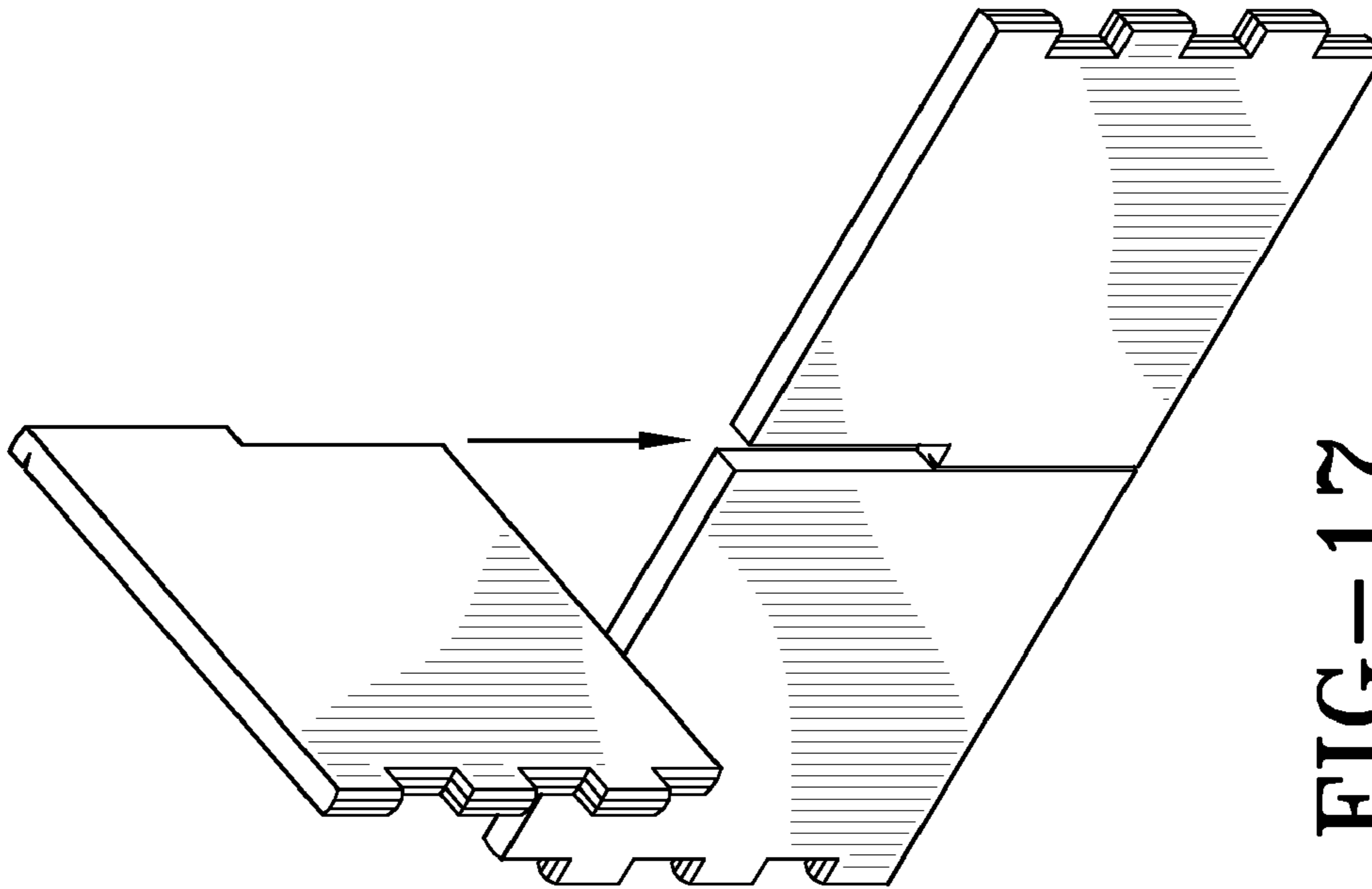

FIG-17

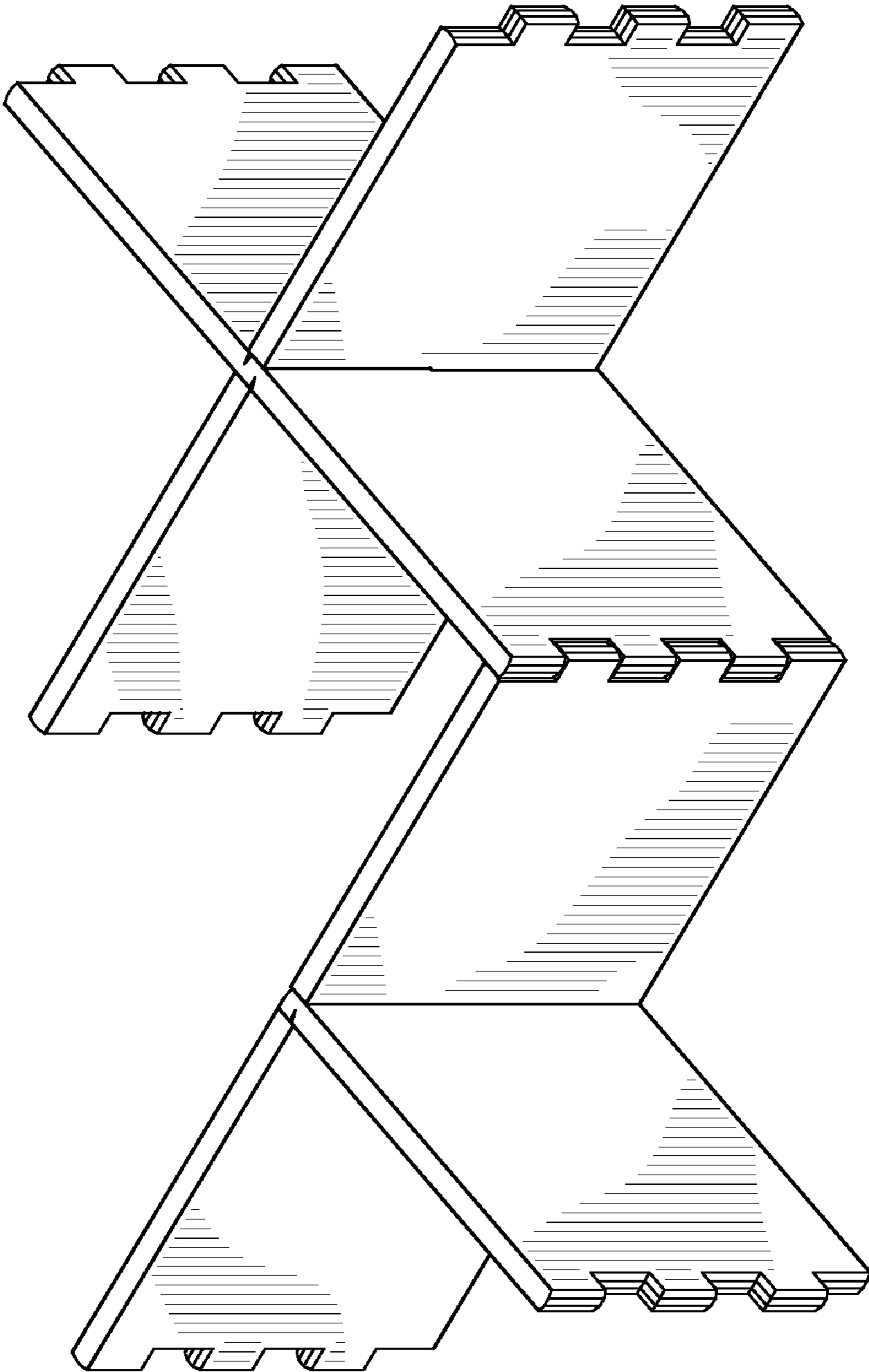

FIG-19

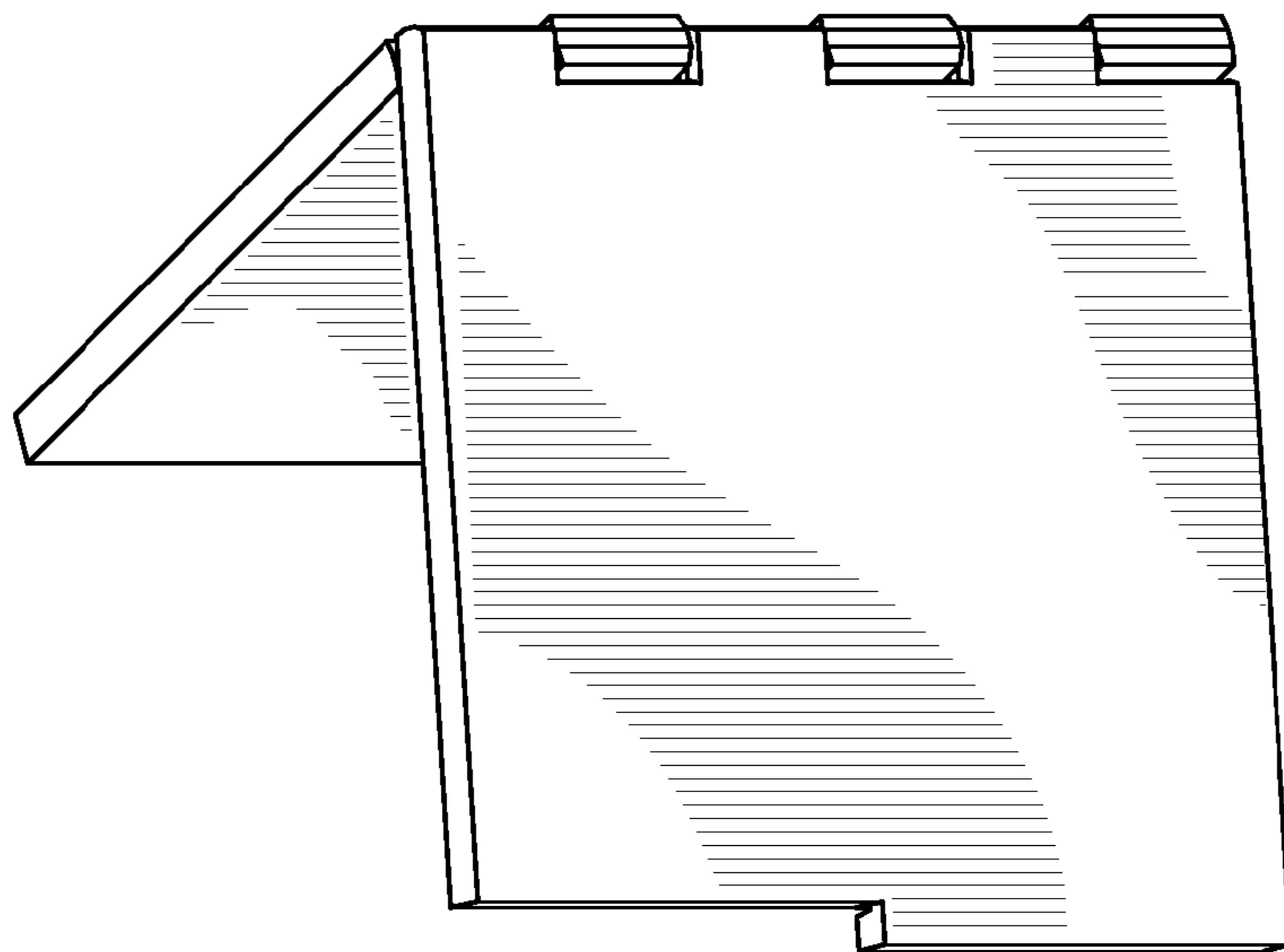

FIG-21

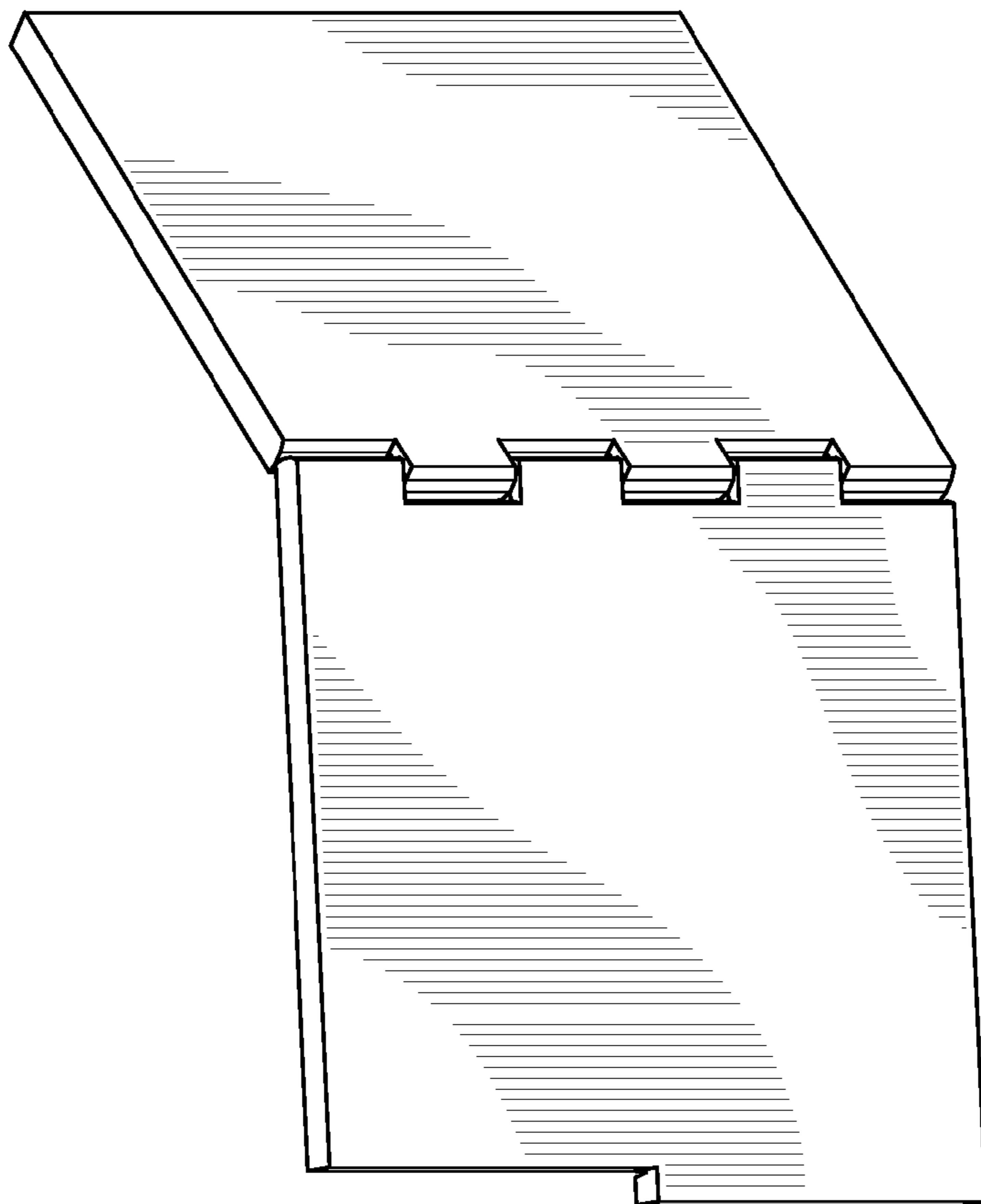

FIG-20