



US00D612918S

(12) **United States Design Patent**  
**Alcebo**

(10) **Patent No.:** **US D612,918 S**  
(45) **Date of Patent:** **\*\* Mar. 30, 2010**

(54) **FLUSH HOSE FOR MULTIPLE OUTBOARD ENGINES**

(74) *Attorney, Agent, or Firm*—McHale & Slavin, P.A.

(76) **Inventor:** **Gerardo Alcebo**, 12506 Westhampton Cir., West Palm Beach, FL (US) 33414

(57) **CLAIM**

The ornamental design for a flush hose for multiple outboard engines, as shown and described.

(\*\*) **Term:** **14 Years**

**DESCRIPTION**

(21) **Appl. No.:** **29/296,605**

FIG. 1 is a front perspective view of a flush hose for multiple outboard engines, showing my new design;

(22) **Filed:** **Oct. 24, 2007**

FIG. 2 is a rear perspective view thereof;

(51) **LOC (9) Cl.** ..... **23-01**

FIG. 3 is a top view thereof;

(52) **U.S. Cl.** ..... **D23/266**

FIG. 4 is a left side view thereof the right side view being a mirror image thereof;

(58) **Field of Classification Search** ..... D23/259–269,  
D23/285, 303, 337, 356; 138/109, 110, 119,  
138/134, 135, 137–146

FIG. 5 is a rear view thereof; and,

See application file for complete search history.

FIG. 6 is a front view thereof.

(56) **References Cited**

The hose is shown broken away with dashed, zig-zag, cut-off lines in the figures to indicate that no specific length is being claimed—it is understood that the interrupted portion of the hose has a uniform shape and appearance through out its length.

**U.S. PATENT DOCUMENTS**

The broken line portion of the figure drawings showing a typical usage environment in FIG. 1 is included to show unclaimed subject matter only and forms no part of the claimed design.

4,553,280	A *	11/1985	Stright	.....	7/157
D354,801	S *	1/1995	Grant et al.	.....	D23/263
5,879,029	A *	3/1999	Wilks	.....	285/8
D456,494	S *	4/2002	Whitfield	.....	D23/266

\* cited by examiner

*Primary Examiner*—Daniel D Bui  
*Assistant Examiner*—Thomas J Johannes

**1 Claim, 5 Drawing Sheets**

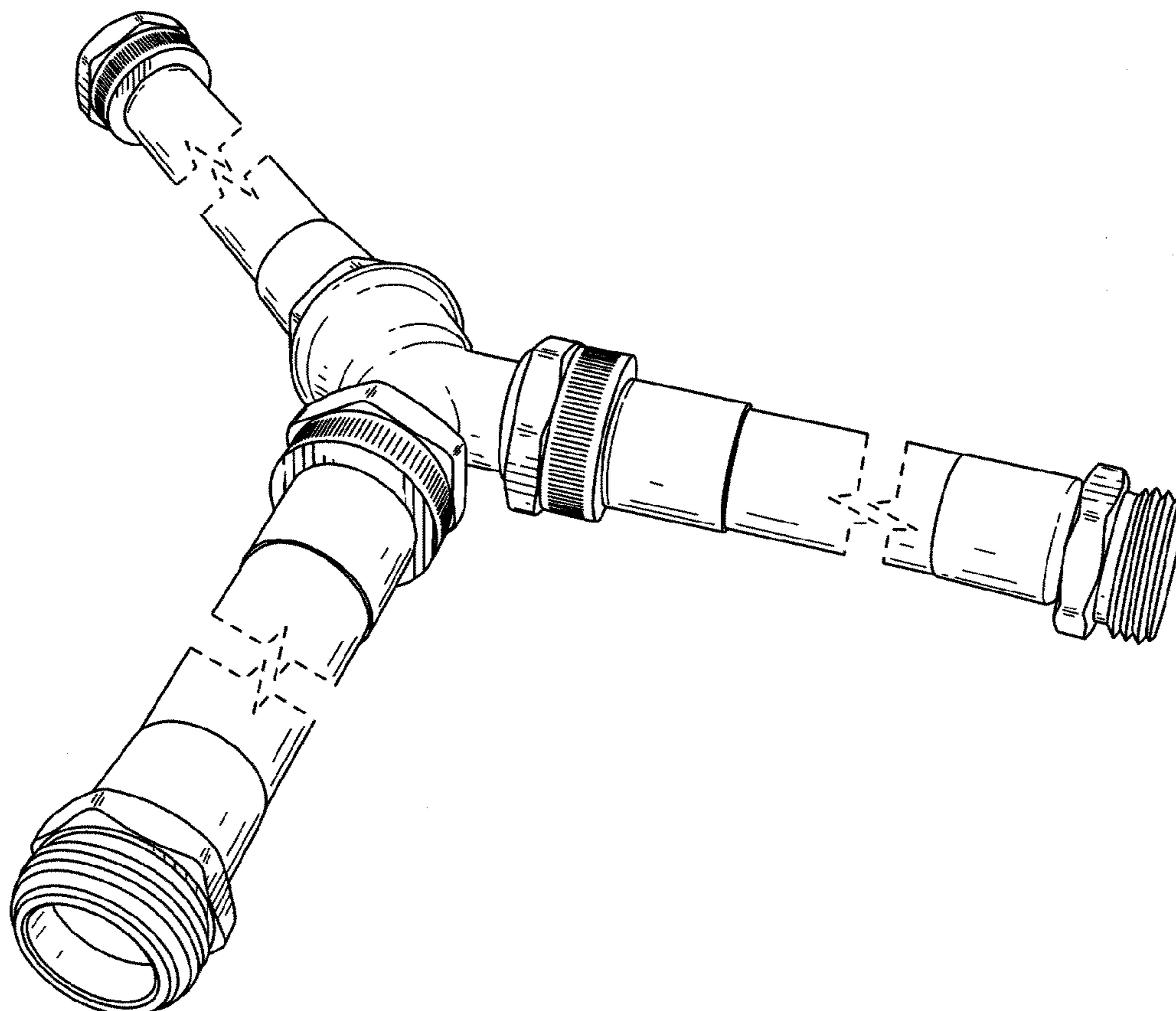

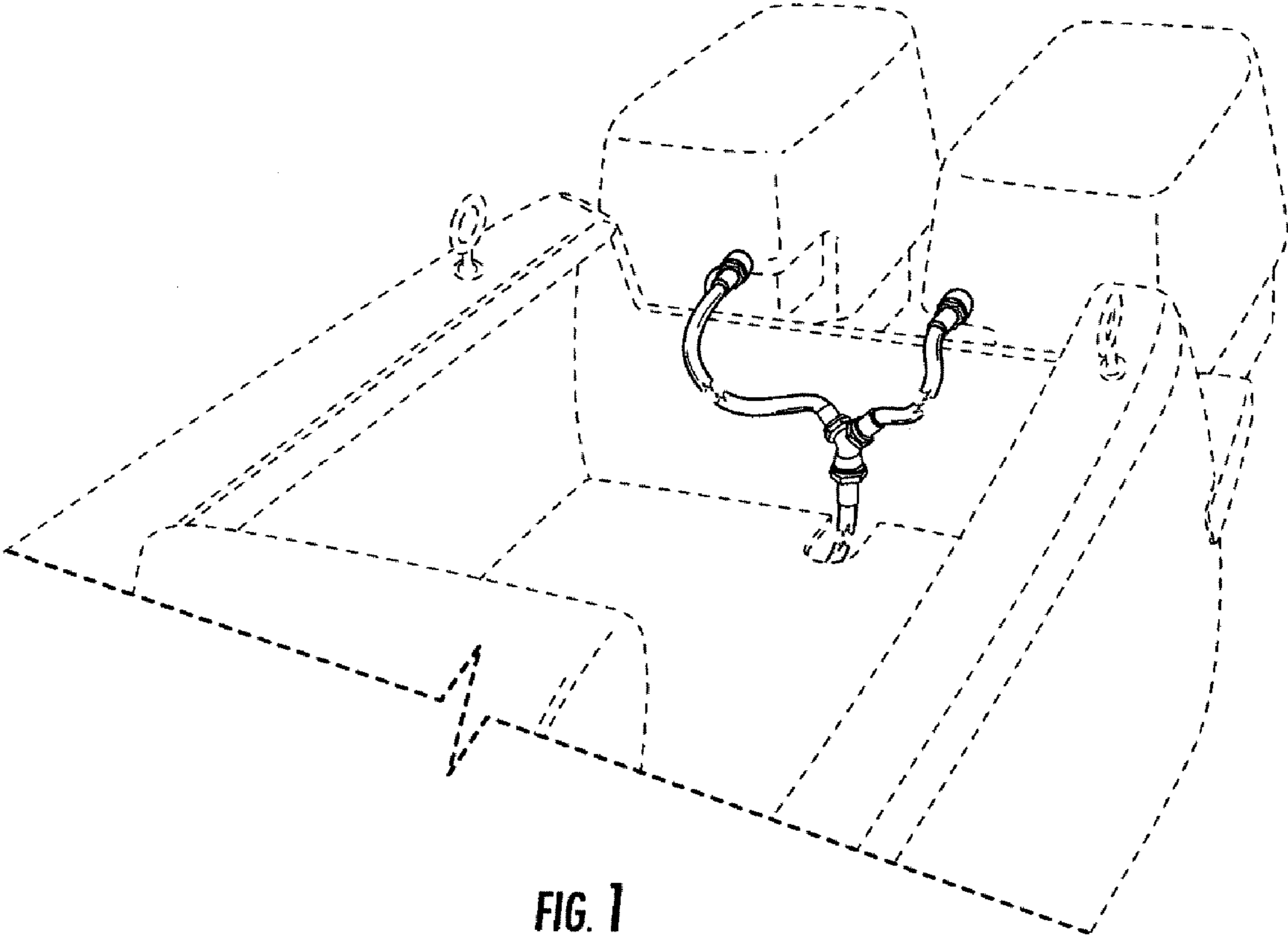

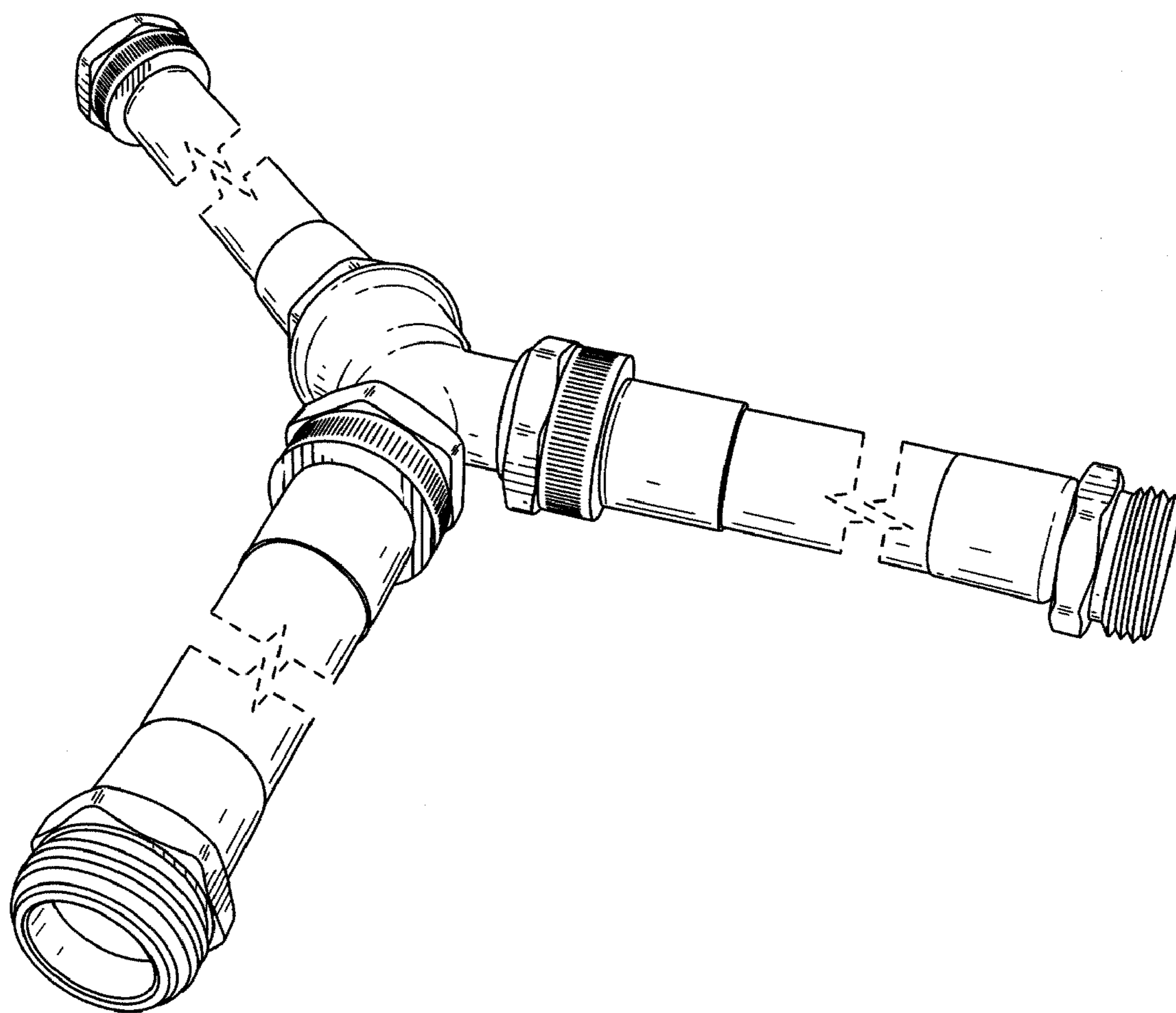

FIG. 2

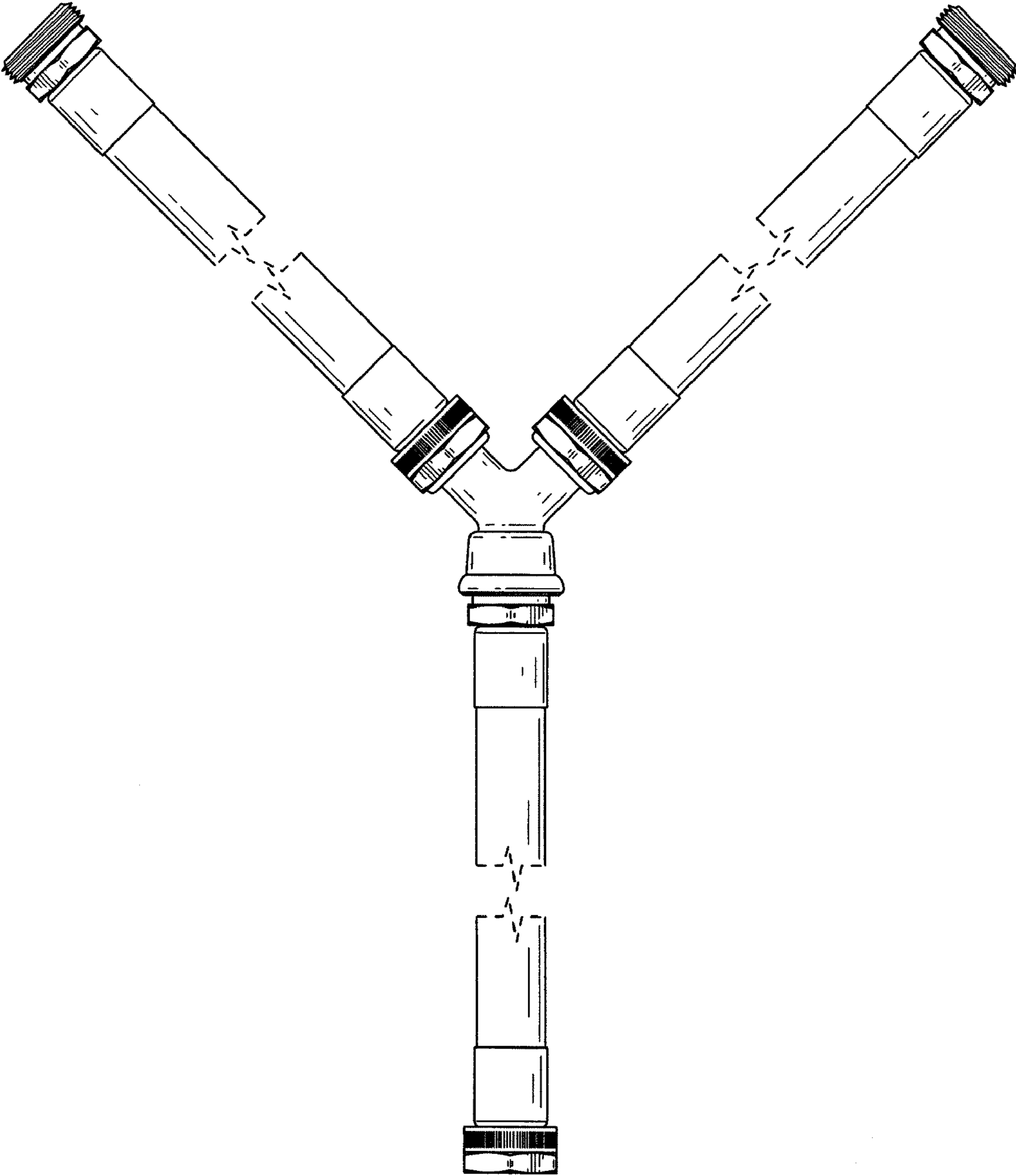
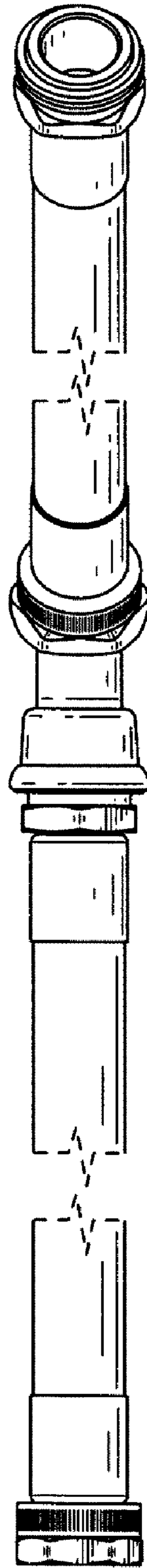

FIG. 3



**FIG. 4**

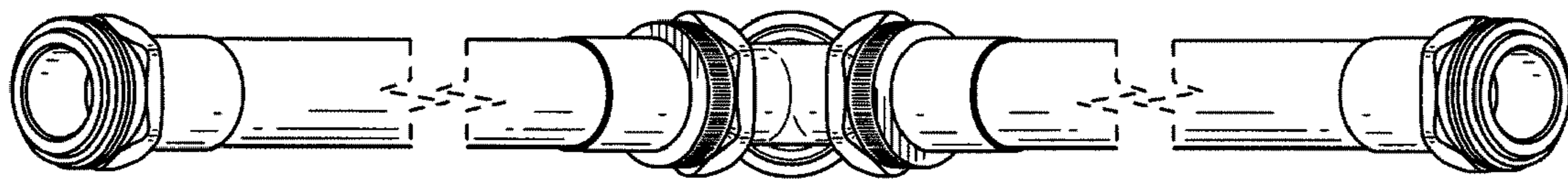

FIG. 5

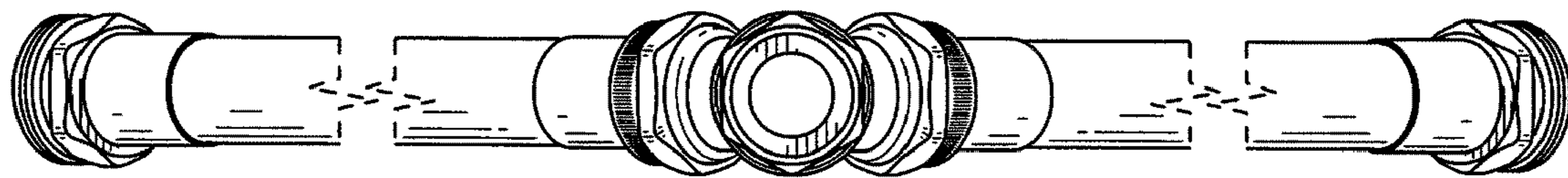

FIG. 6