



US00D612873S

(12) **United States Design Patent**  
**Spinelli et al.**

(10) **Patent No.:** **US D612,873 S**  
(45) **Date of Patent:** **\*\* Mar. 30, 2010**

(54) **MILLING MACHINE**

(75) Inventors: **Nico Spinelli**, Zurich (CH); **Tom Staebli**, Zurich (CH); **Daniel Iranyi**, Steinhausen (CH)

(73) Assignee: **Wieland Dental & Technik GmbH & Co. KG**, Pforzheim (DE)

(\*\*) Term: **14 Years**

(21) Appl. No.: **29/316,179**

(22) Filed: **Sep. 1, 2009**

(30) **Foreign Application Priority Data**

Mar. 6, 2009 (EM) ..... 001099162-0003

(51) **LOC (9) Cl.** ..... **15-09**

(52) **U.S. Cl.** ..... **D15/131**

(58) **Field of Classification Search** ..... D6/432, D6/436, 470-472; D15/122, 123, 124, 127, D15/131; 29/560, 568; 209/139.1; 241/37, 241/65, 79.1, 80, 117, 119, 121, 130, 159, 241/224, 227, 230, 232, 234, 235, 260; 408/38; 409/64, 89, 160, 201, 210  
See application file for complete search history.

(56) **References Cited**

**U.S. PATENT DOCUMENTS**

D129,859 S \* 10/1941 Carlson ..... D15/131  
3,881,663 A \* 5/1975 Brown ..... 241/225  
D302,163 S \* 7/1989 Itoh et al. .... D15/122

D328,467 S \* 8/1992 Maleschew ..... D15/131  
D419,165 S \* 1/2000 Muller et al. .... D15/127  
D495,723 S \* 9/2004 Kawamura et al. .... D15/127  
D542,311 S \* 5/2007 Inaba et al. .... D15/127  
D552,134 S \* 10/2007 Nakano ..... D15/131

\* cited by examiner

*Primary Examiner*—Sandra Snapp

*Assistant Examiner*—Patricia Palasik

(74) *Attorney, Agent, or Firm*—Flynn, Thiel, Boutell & Tanis, P.C.

(57) **CLAIM**

The ornamental design for a milling machine, as shown and described.

**DESCRIPTION**

FIG. 1 is a front perspective view-of a milling machine showing our new design;

FIG. 2 is a front elevation view thereof;

FIG. 3 is a right side elevation view thereof;

FIG. 4 is a left side elevation view thereof;

FIG. 5 is a rear elevation view thereof;

FIG. 6 is a front perspective view thereof with the right cover in an open position; and

FIG. 7 is a front perspective view thereof with the left cover in an open position.

The broken lines in the drawings depict unclaimed environmental subject matter.

**1 Claim, 7 Drawing Sheets**

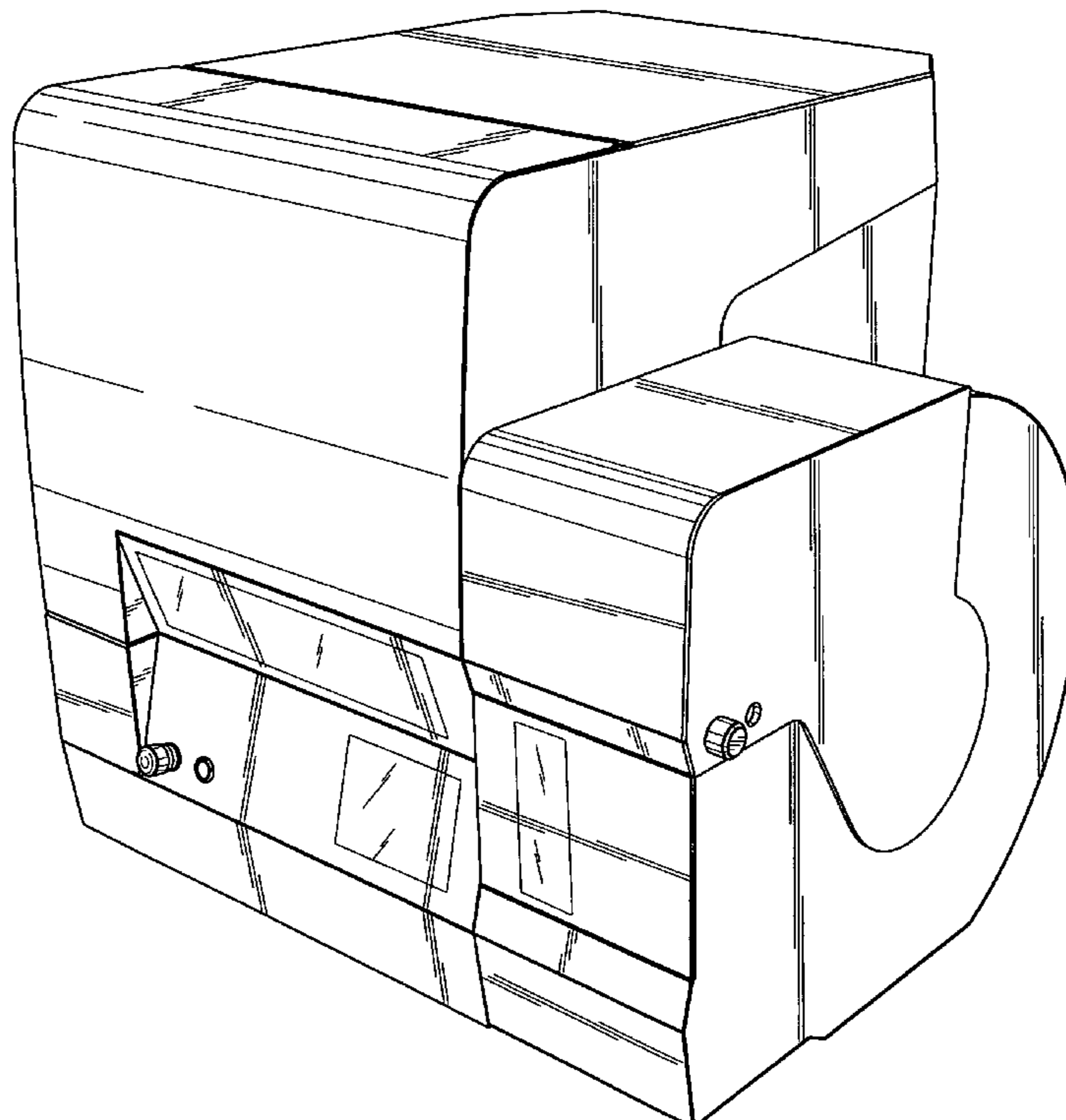

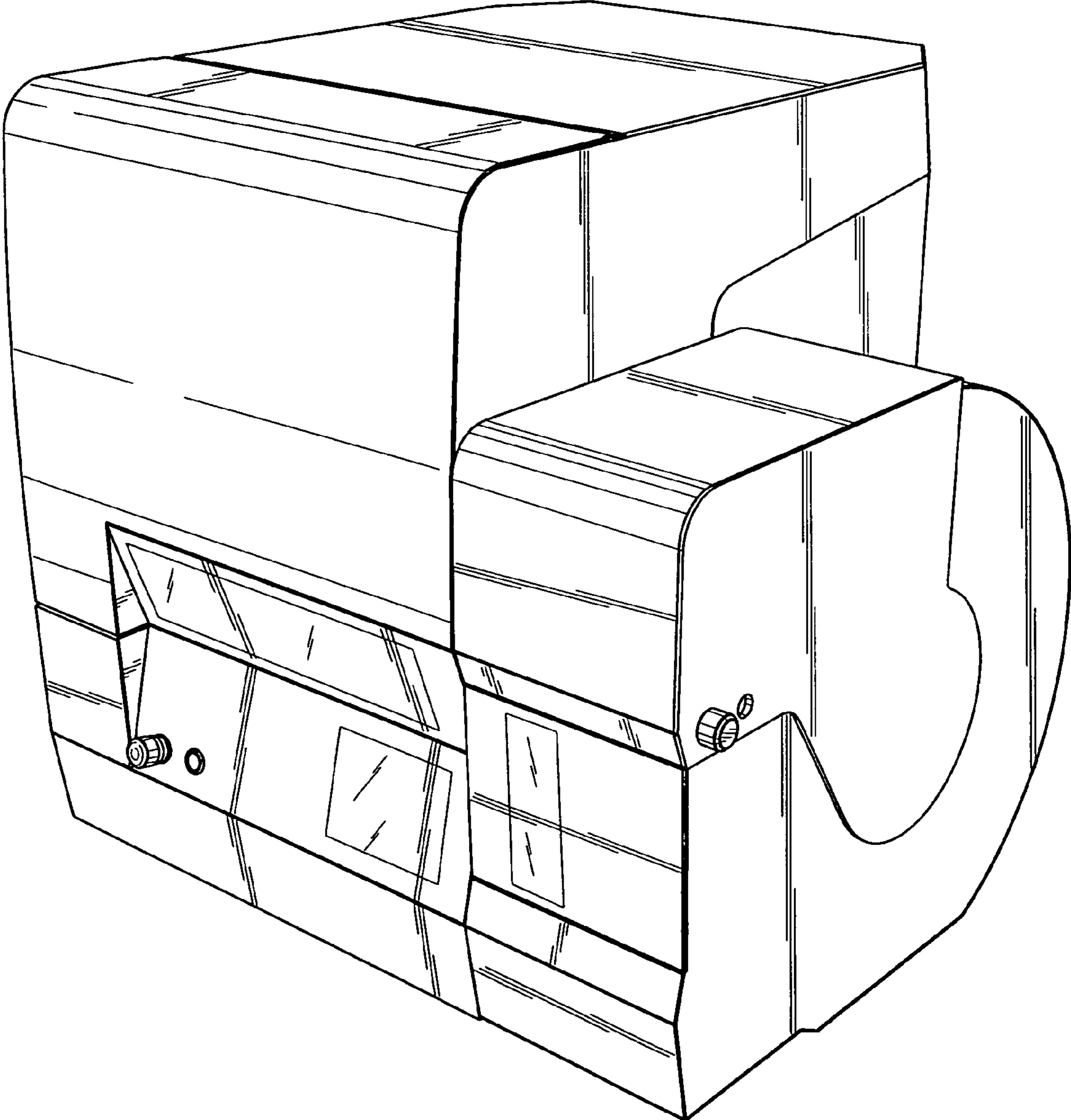

FIG. 1

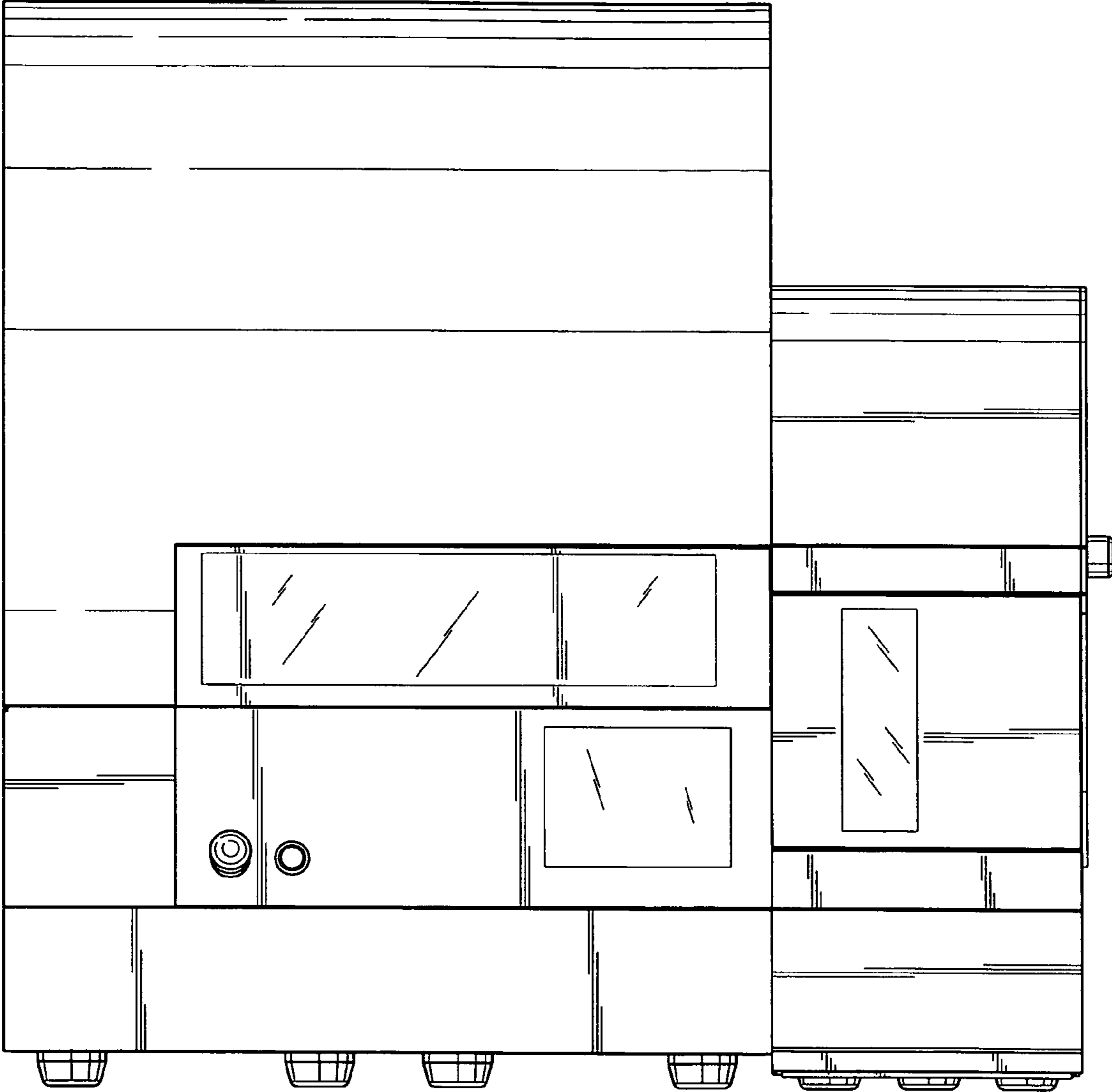

FIG. 2

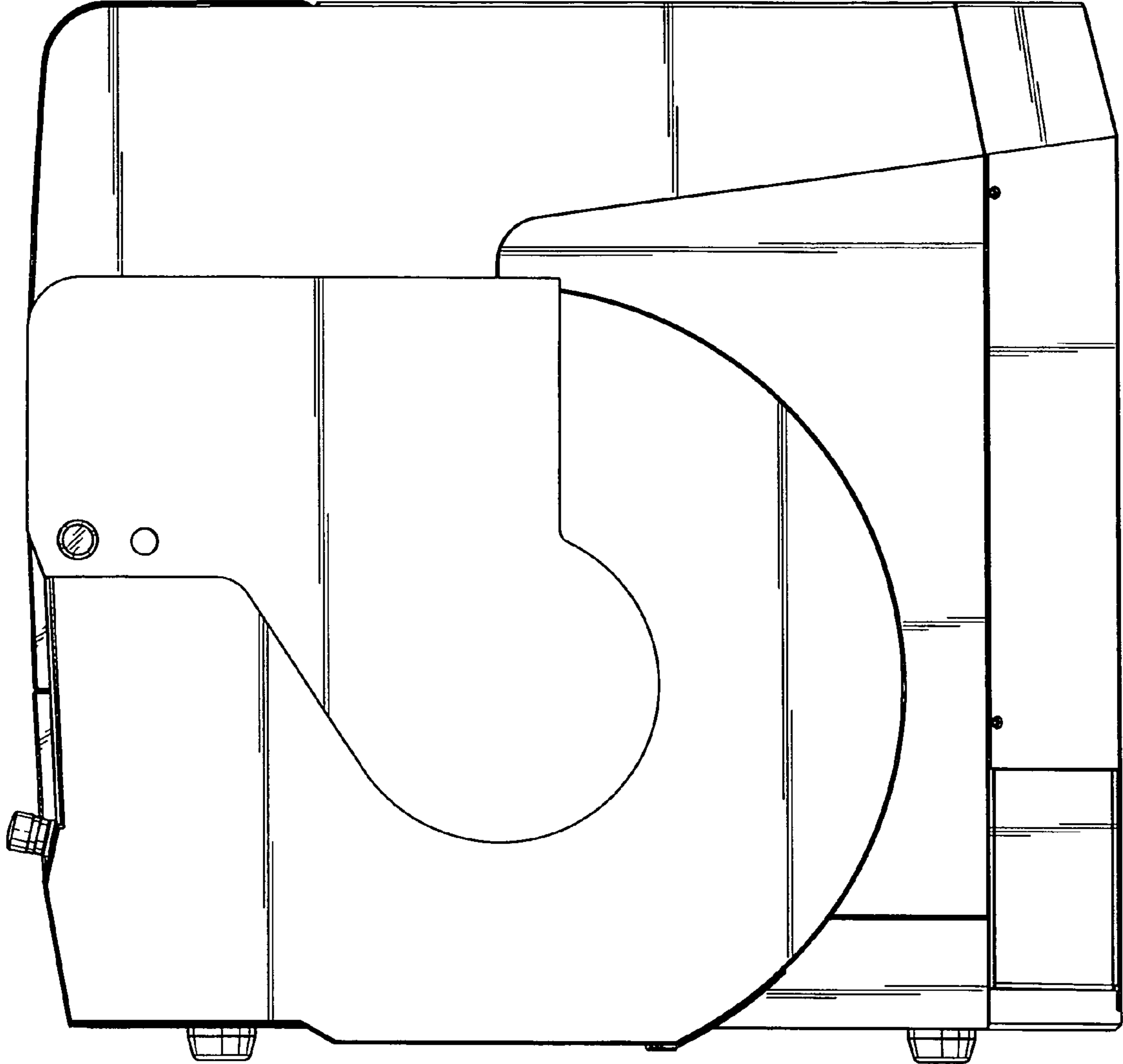

FIG. 3

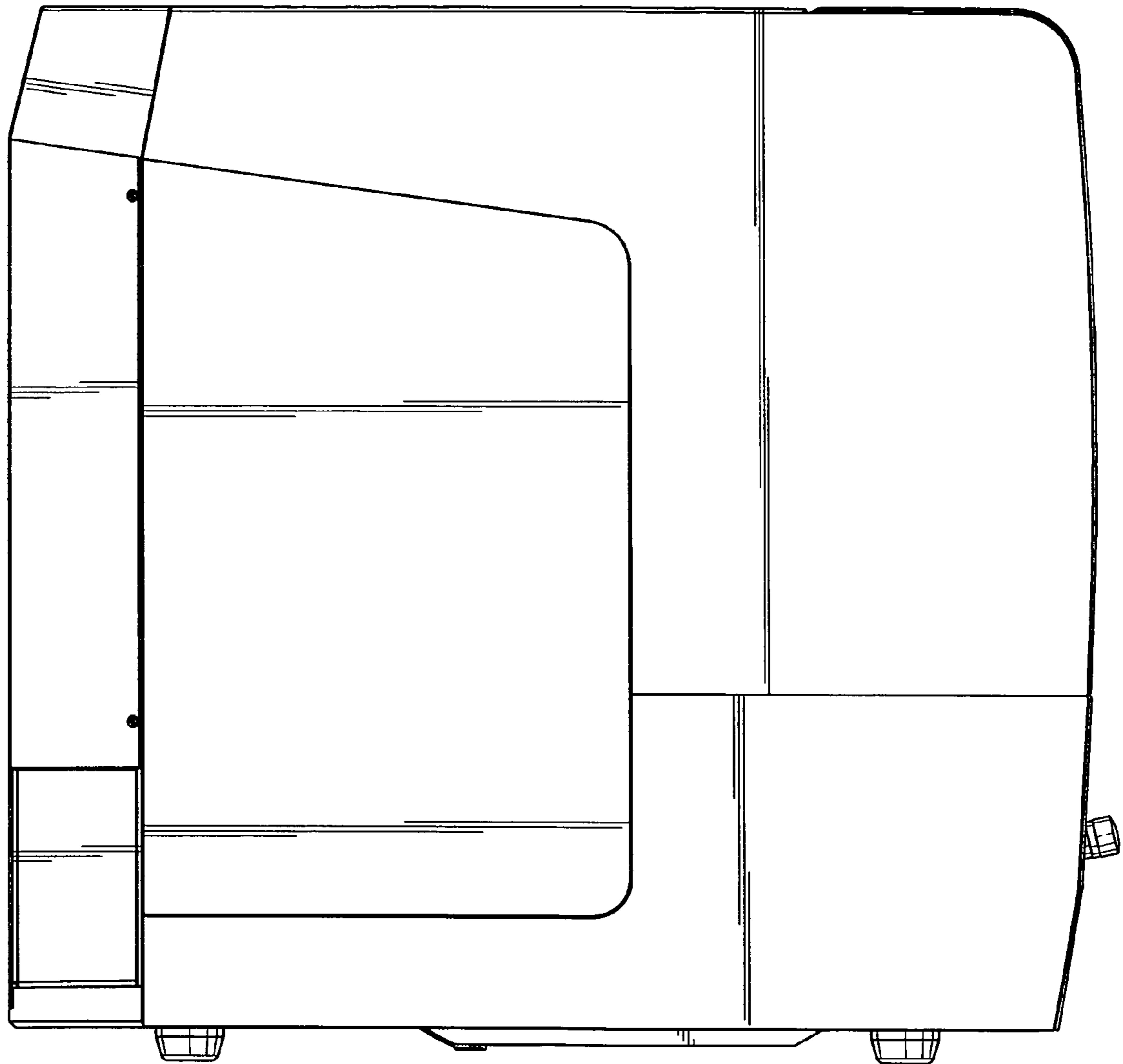

FIG. 4

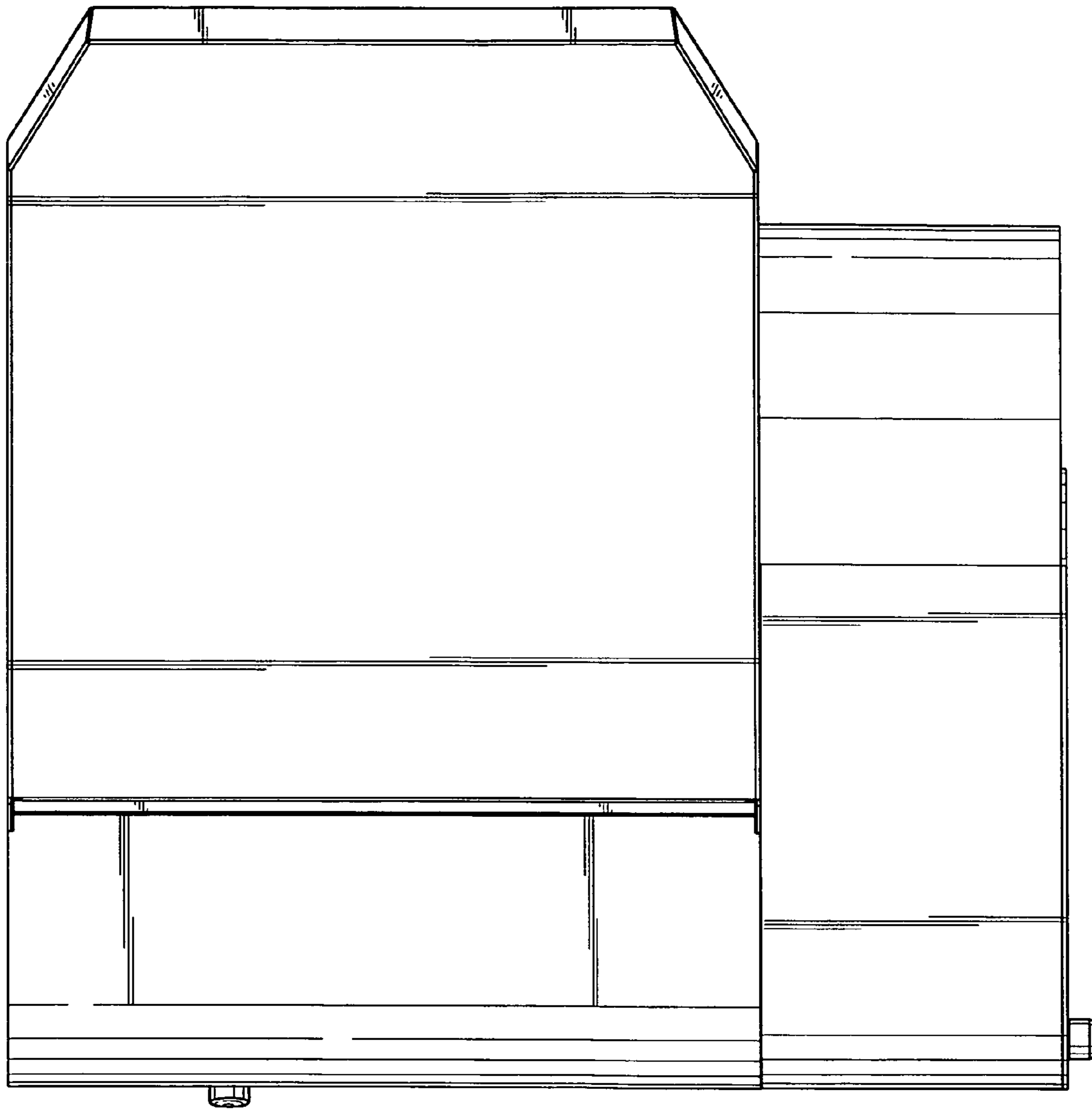

FIG. 5

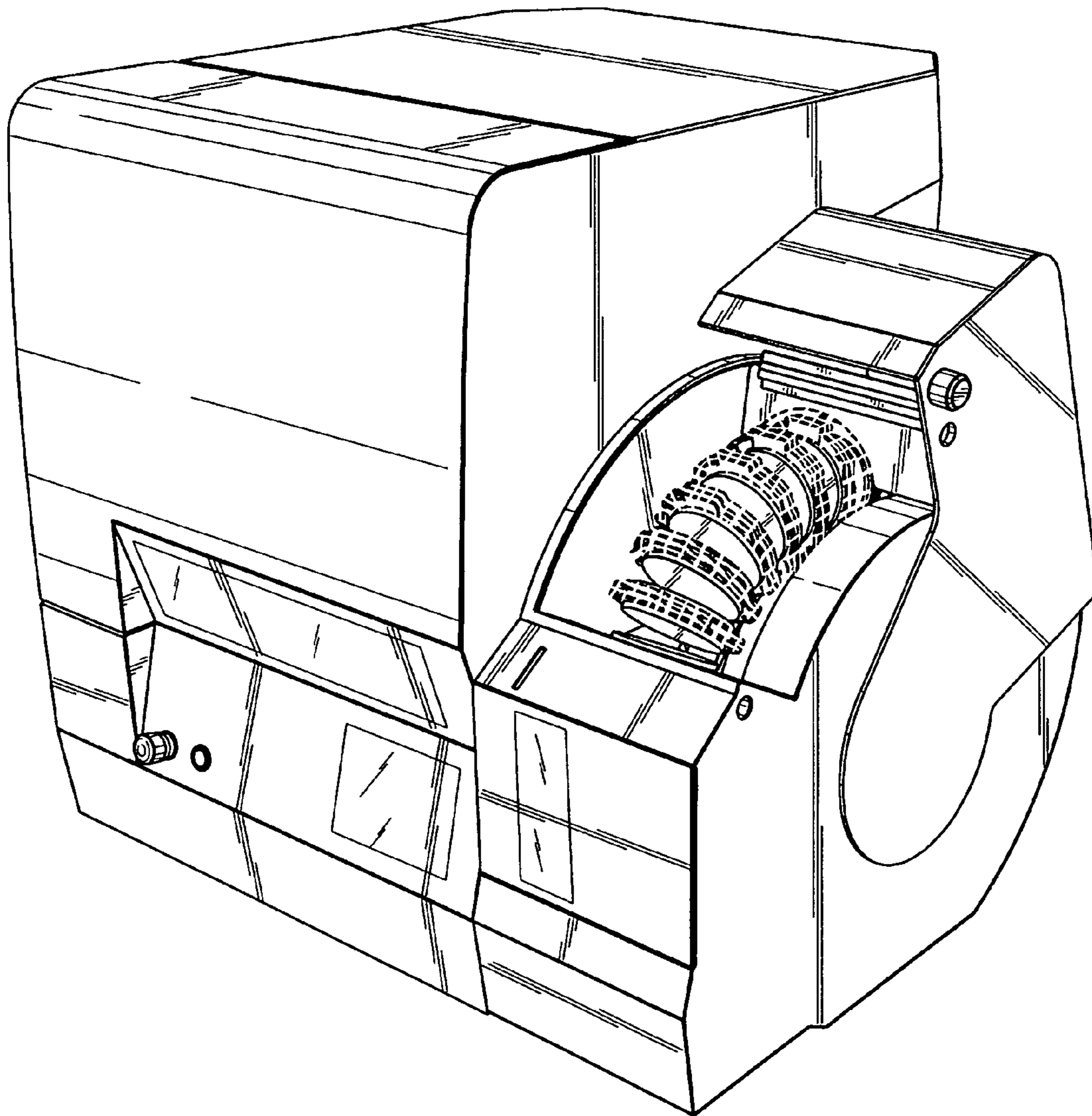

FIG. 6

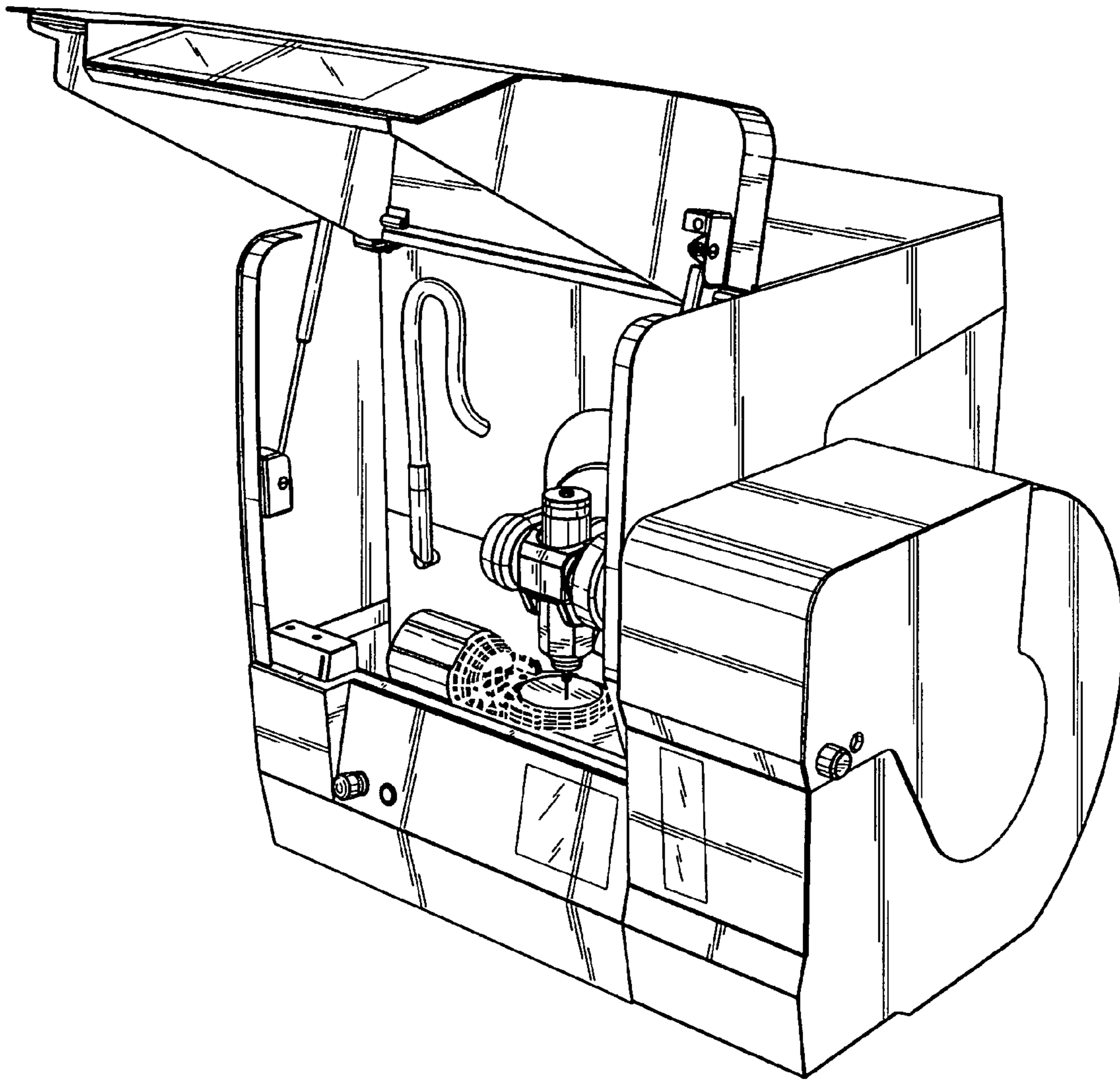

FIG. 7