



US00D612791S

(12) **United States Design Patent**
Morgan et al.

(10) **Patent No.:** **US D612,791 S**
(45) **Date of Patent:** **** Mar. 30, 2010**

(54) **AIRCRAFT**

(75) Inventors: **Robert Joseph Morgan**, Mojave, CA
(US); **James Joseph Tighe**, Mojave, CA
(US)

(73) Assignee: **TSC LLC**, New York, NY (US)

(**) Term: **14 Years**

(21) Appl. No.: **29/321,924**

(22) Filed: **Jul. 25, 2008**

(51) **LOC (9) Cl.** **12-07**

(52) **U.S. Cl.** **D12/319**

(58) **Field of Classification Search** D12/319,
D12/326, 329, 333, 334, 335, 337, 340, 341,
D12/343; D21/436, 447, 448, 451; 244/45 A,
244/45 R, 13, 15, 29, 46, 55, 91, 199; 446/30-34,
446/55-56, 231

See application file for complete search history.

(56) **References Cited**

U.S. PATENT DOCUMENTS

D232,711 S * 9/1974 Kirchner et al. D12/335
D277,200 S * 1/1985 Johnston D21/451
D291,555 S * 8/1987 Rosenthal D12/334
D369,776 S * 5/1996 Kraft et al. D12/344

D370,456 S * 6/1996 Buchsel et al. D12/340
D415,993 S * 11/1999 Birrenbach D12/337
D422,650 S * 4/2000 Wei D21/451
D596,267 S * 7/2009 Colgren et al. D12/319

* cited by examiner

Primary Examiner—Cathron C. Brooks

Assistant Examiner—Maurice Stevens

(74) *Attorney, Agent, or Firm*—Ostrolenk Faber LLP

(57) **CLAIM**

The ornamental design for an aircraft, as shown and described.

DESCRIPTION

FIG. 1 is an overhead perspective view of an aircraft according to an embodiment of the present invention;

FIG. 2 is an underside perspective view thereof;

FIG. 3 is a front elevation view thereof;

FIG. 4 is a rear elevation view thereof;

FIG. 5 is a top plan view thereof;

FIG. 6 is a bottom plan view thereof;

FIG. 7 is a left side elevation view thereof; and,

FIG. 8 is a right side elevation view thereof.

1 Claim, 6 Drawing Sheets

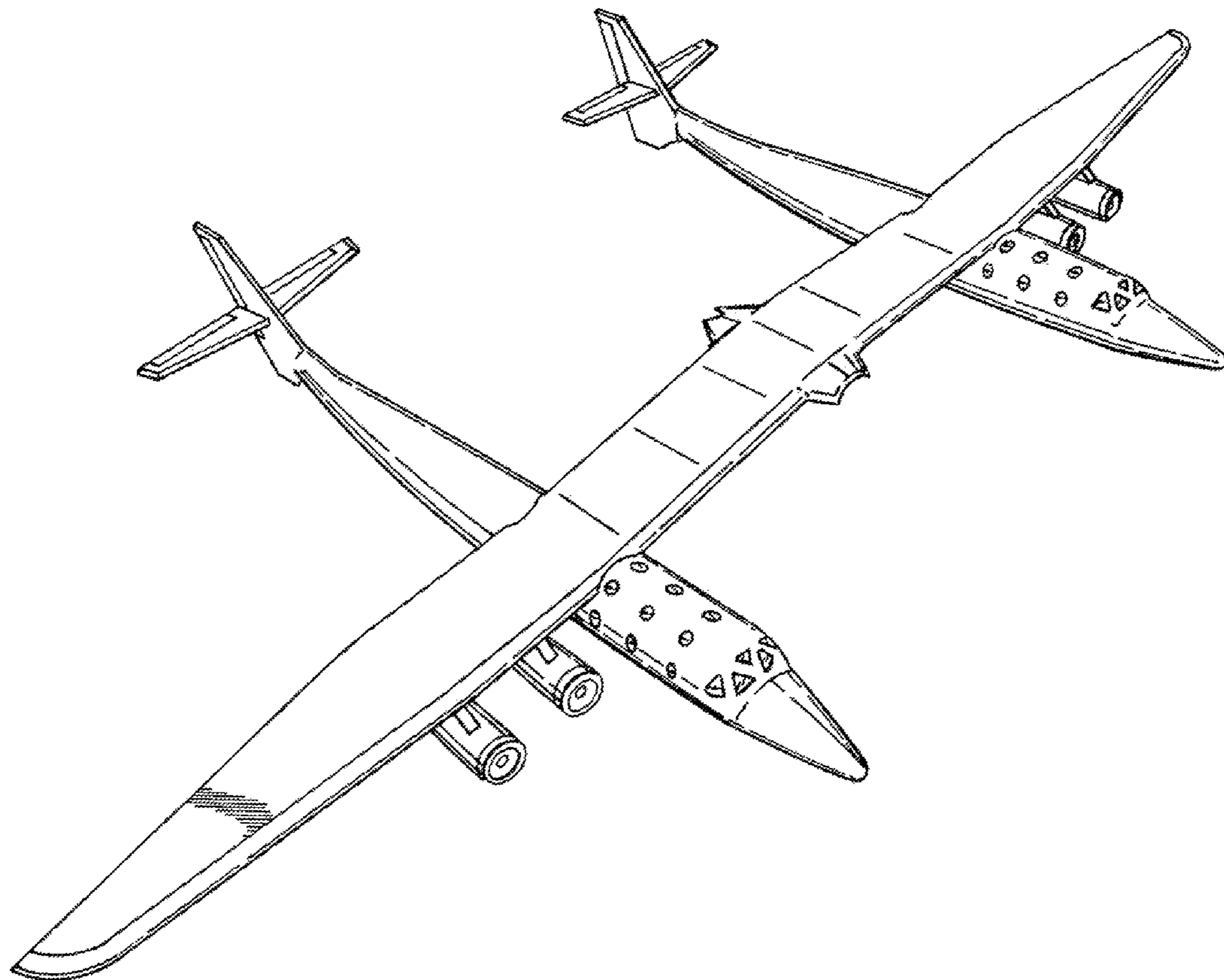

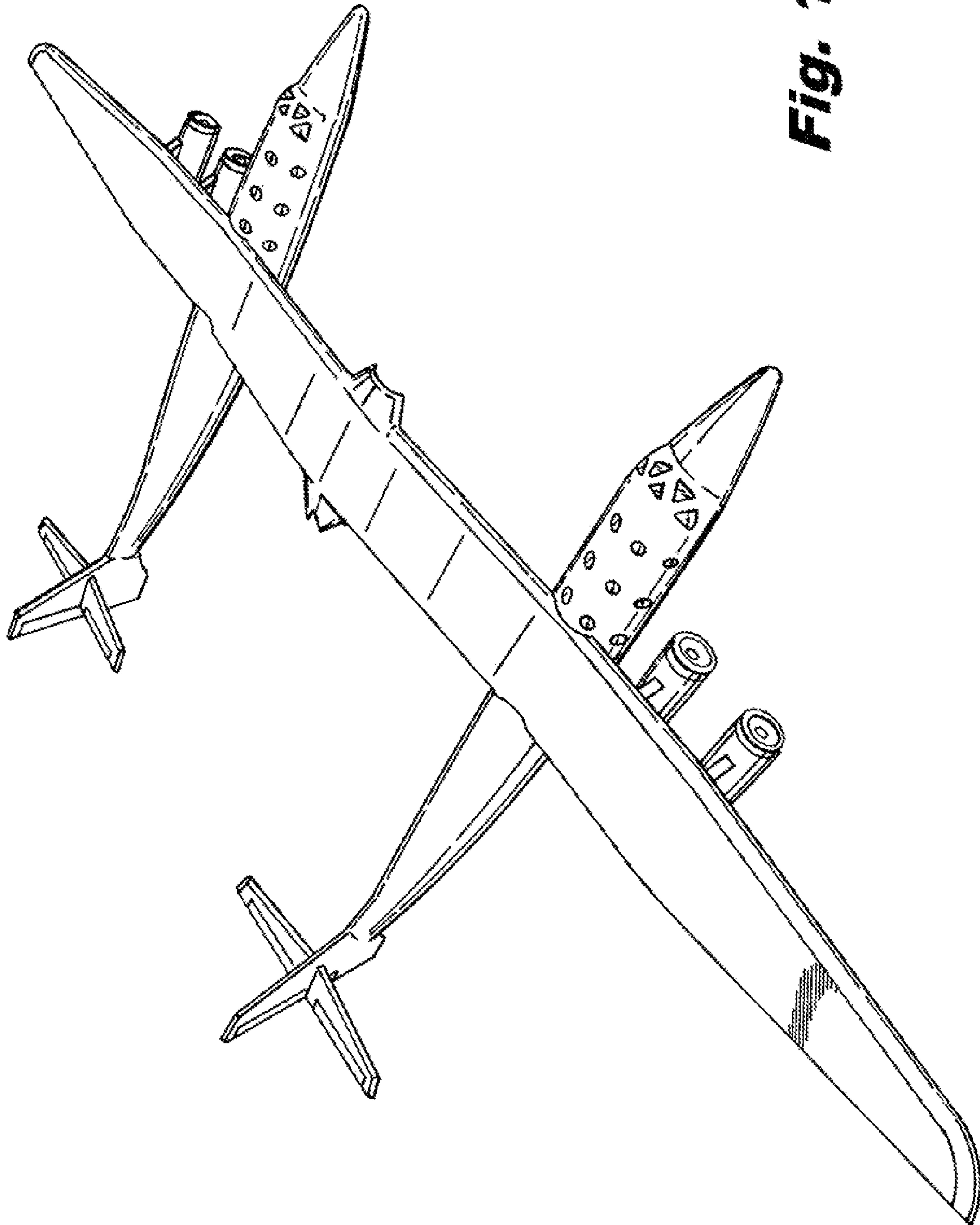
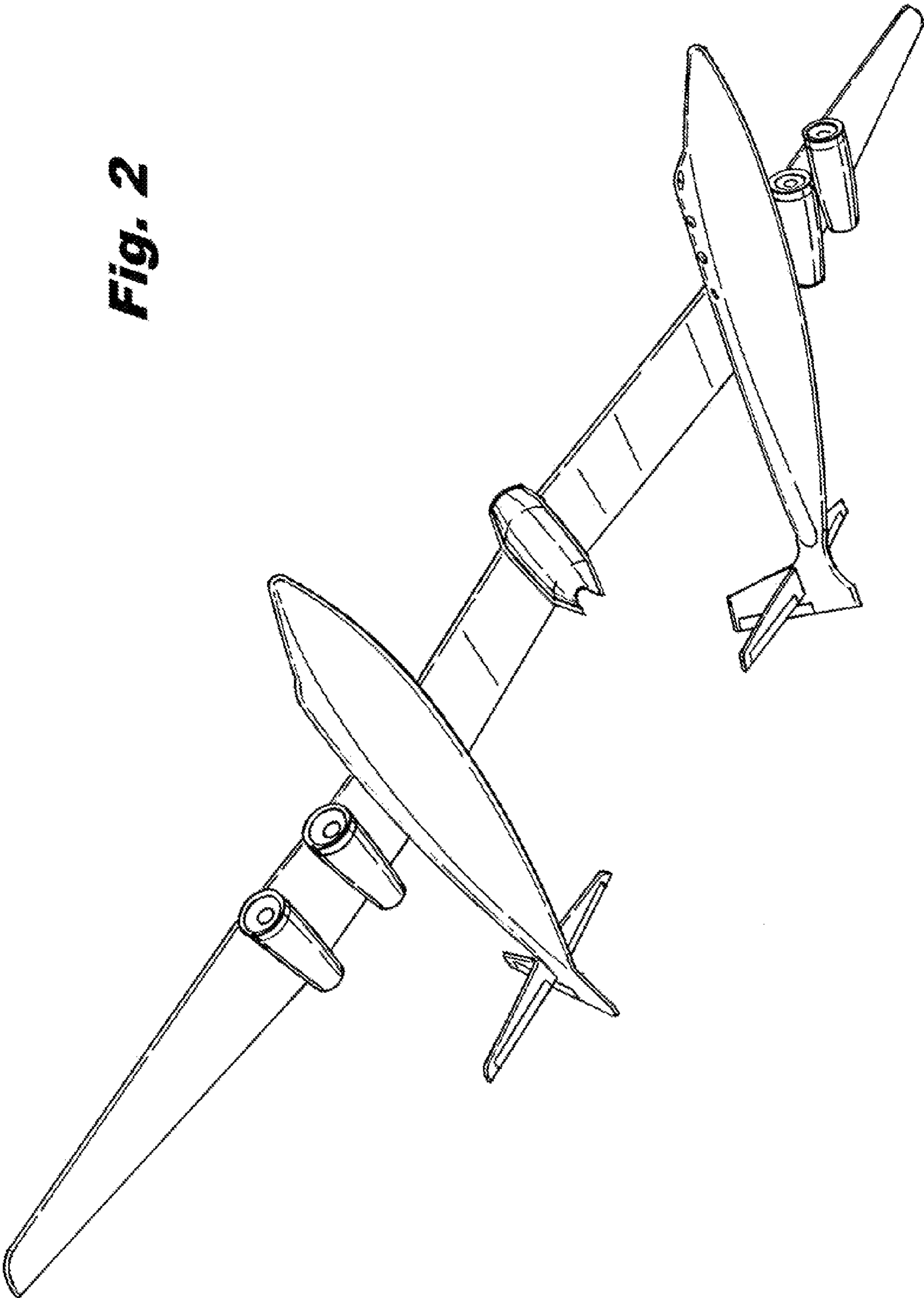

Fig. 1

Fig. 2



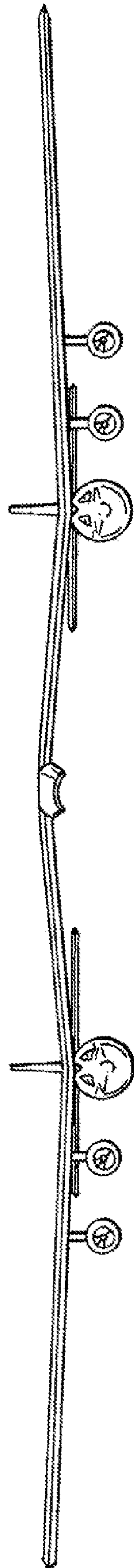

Fig. 3

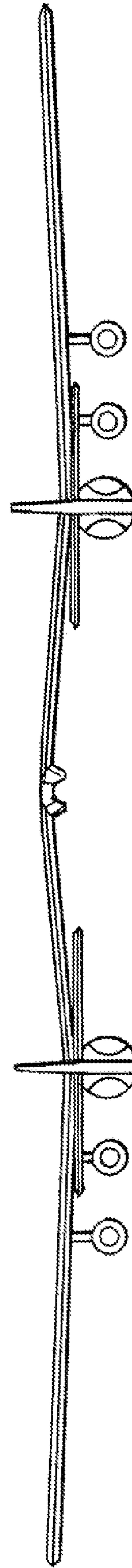

Fig. 4

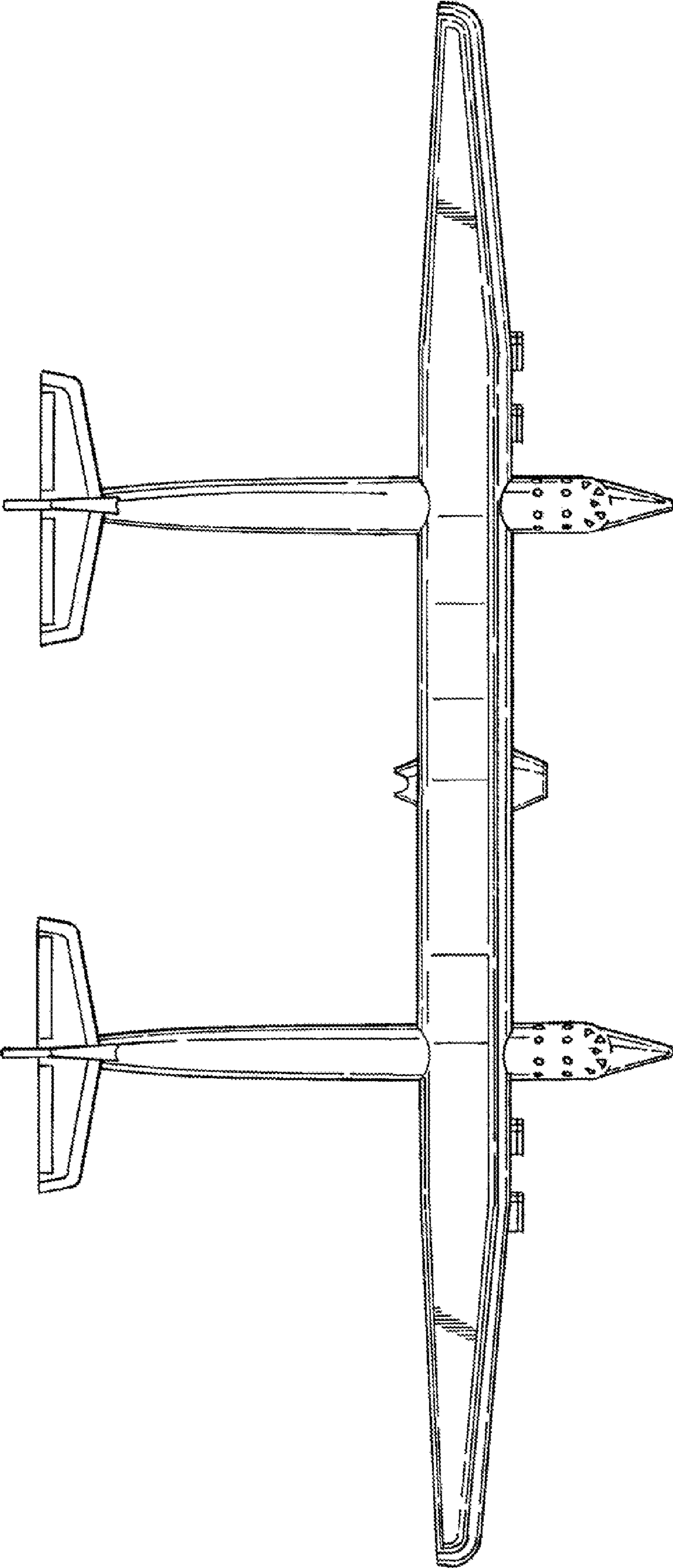

Fig. 5

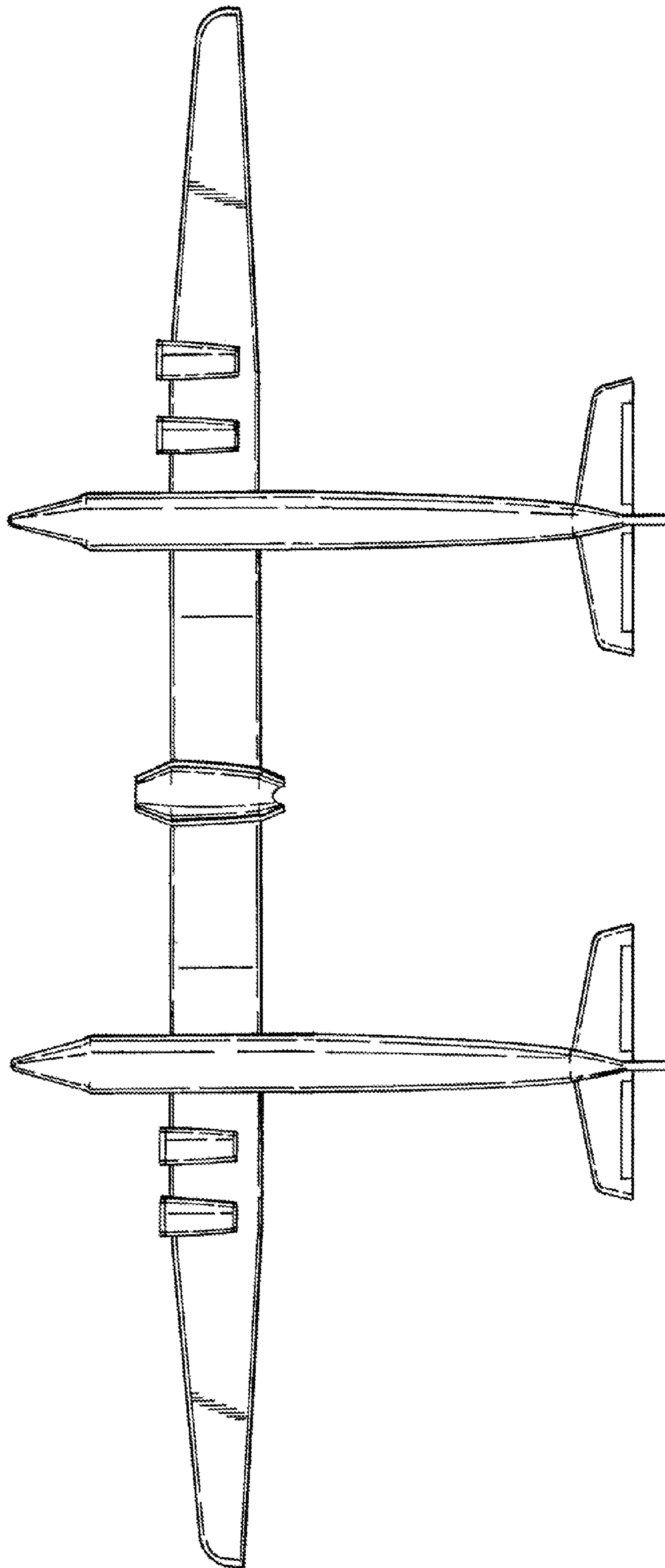

Fig. 6



Fig. 7

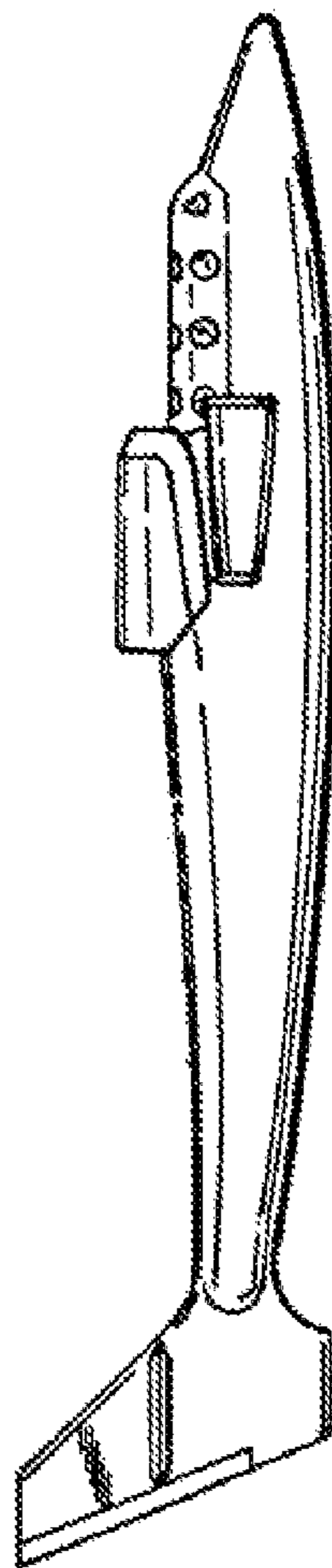

Fig. 8