



US00D612786S

(12) **United States Design Patent**
Hildebrand et al.

(10) **Patent No.:** **US D612,786 S**
(45) **Date of Patent:** **** Mar. 30, 2010**

(54) **DOOR FOR A VEHICLE**

D558,112 S * 12/2007 Leclercq D12/196
D583,289 S * 12/2008 Leclercq D12/196

(75) Inventors: **Gert Hildebrand**, Munich (DE);
Marcus Syring, Munich (DE)

FOREIGN PATENT DOCUMENTS

EM 000482419-0005 10/2006

(73) Assignee: **Bayerische Motoren Werke**
Aktiengesellschaft, Munich (DE)

* cited by examiner

(**) Term: **14 Years**

Primary Examiner—Robert M Spear
Assistant Examiner—Cynthia Underwood
(74) *Attorney, Agent, or Firm*—Crowell & Moring LLP

(21) Appl. No.: **29/287,954**

(57) **CLAIM**

(22) Filed: **Oct. 3, 2007**

The ornamental design for a door for a vehicle, as shown and described.

(30) **Foreign Application Priority Data**

DESCRIPTION

Apr. 4, 2007 (DE) 4 07 01 920

This application is related to the following co-pending application, of the inventors, filed on even date herewith:

(51) **LOC (9) Cl.** **12-16**

(52) **U.S. Cl.** **D12/196**

(58) **Field of Classification Search** D12/196,
D12/190, 400, 86, 90–92; D21/548; 116/22 A,
116/137 R; 296/181.1, 181.5

Application Ser. No. 29/287,949, entitled “Vehicle, Toy, and/or Other Replicas”.

See application file for complete search history.

FIG. 1 is a right perspective view of a first embodiment of a door for a vehicle according to our novel design;

FIG. 2 is a left perspective view thereof;

(56) **References Cited**

U.S. PATENT DOCUMENTS

- D235,429 S * 6/1975 Brown D12/196
- D236,103 S * 7/1975 Field D12/196
- D405,389 S * 2/1999 Trostle et al. D12/92
- D405,390 S * 2/1999 Castiglione et al. D12/92
- D409,262 S 5/1999 Stephenson
- D422,957 S * 4/2000 Damon et al. D12/196
- D433,980 S * 11/2000 Conway et al. D12/196
- D467,851 S * 12/2002 Warming D12/196
- D490,022 S * 5/2004 Sims et al. D12/92
- D491,859 S * 6/2004 Velazco D12/196
- D508,876 S * 8/2005 Kim et al. D12/92
- D511,128 S * 11/2005 Nagashima D12/196
- D521,434 S 5/2006 Fisker et al.
- D540,714 S 4/2007 Mueller-Stolz

FIG. 3 is a front view thereof;

FIG. 4 is a right side view thereof; and

FIG. 5 is a top view thereof.

FIG. 6 is a left perspective view of a second embodiment of the door for a vehicle according to our novel design;

FIG. 7 is a right perspective view thereof;

FIG. 8 is a left side view thereof;

FIG. 9 is a front view thereof; and,

FIG. 10 is a top view thereof.

The broken lines represent portions of the design that form no part of the claim.

1 Claim, 4 Drawing Sheets

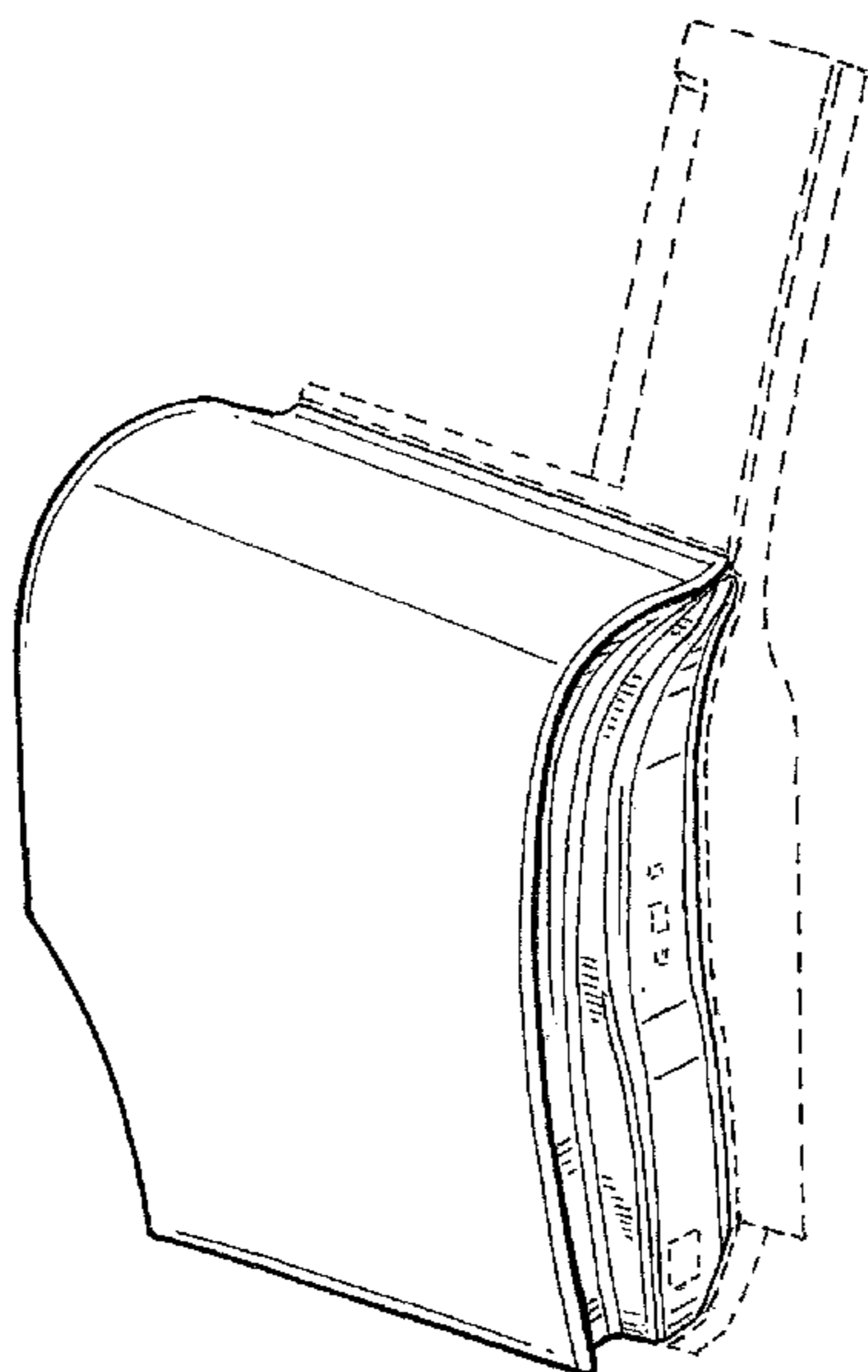

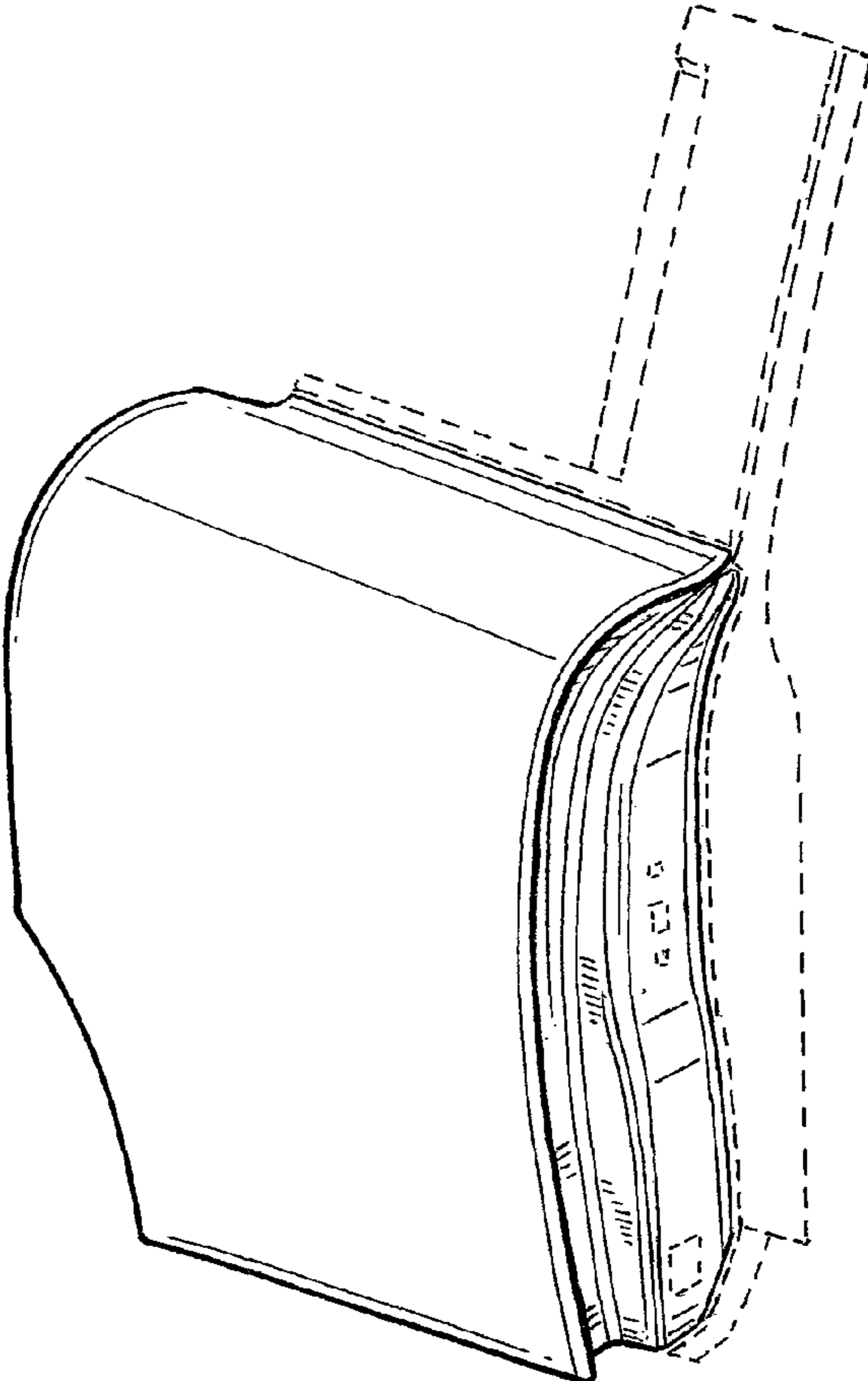

FIG. 1

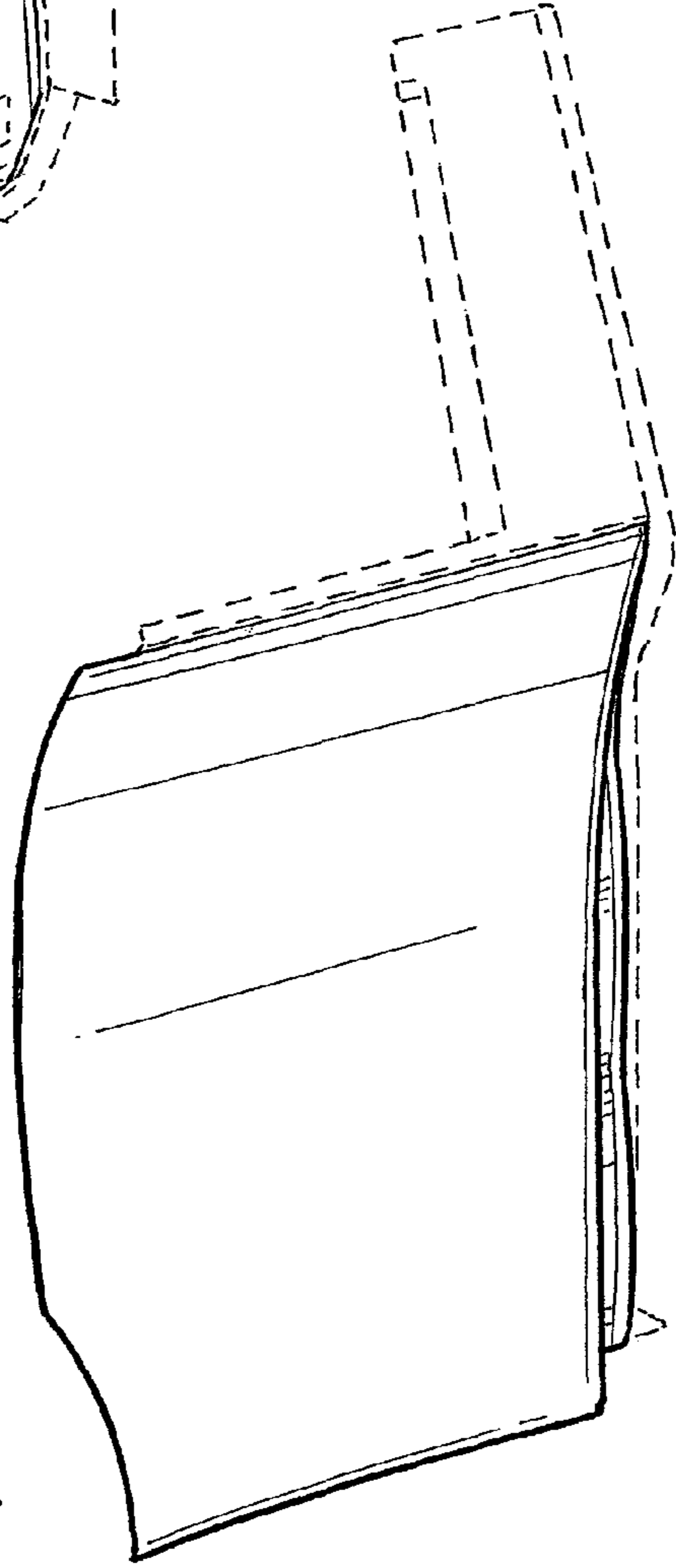

FIG. 2

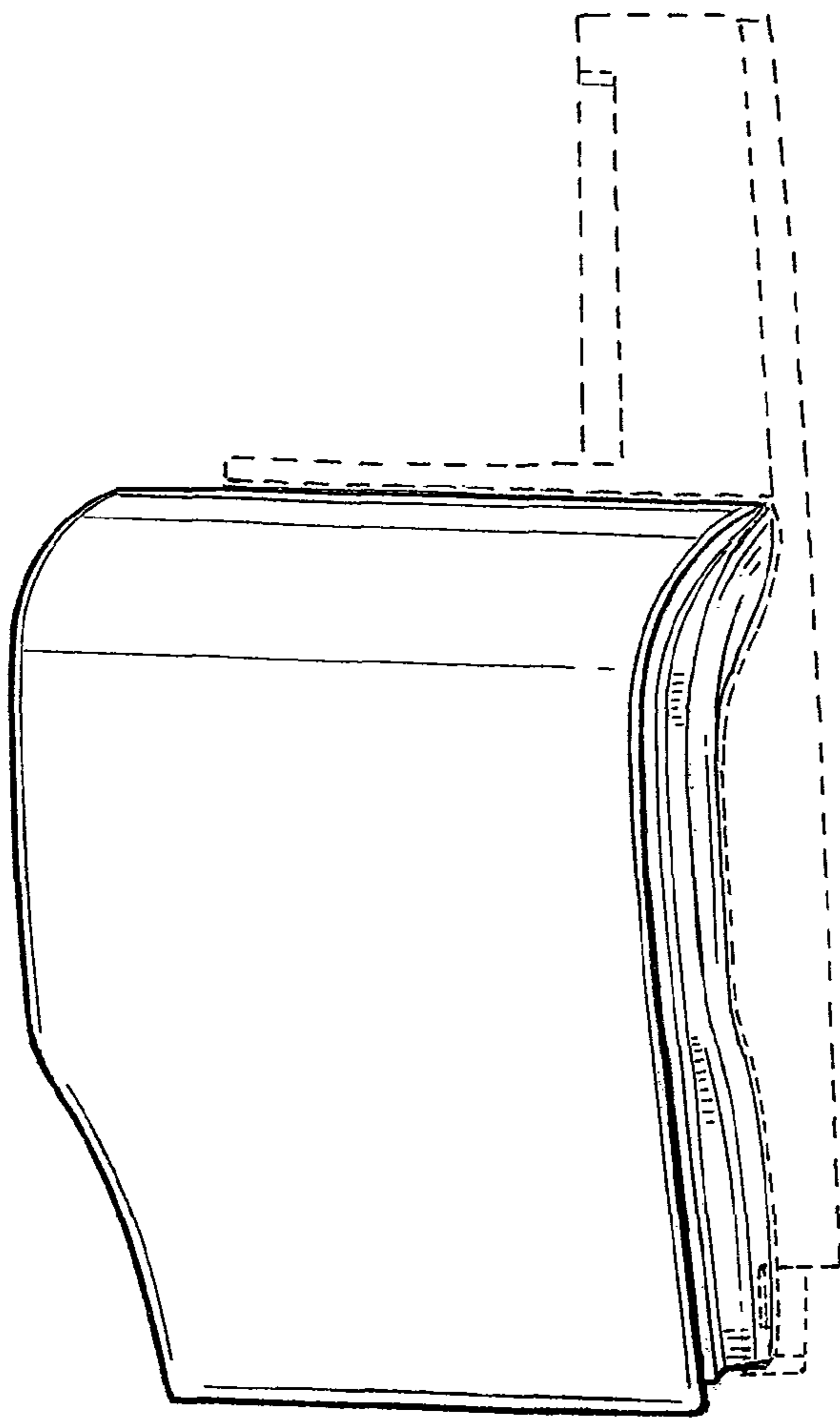

FIG. 3

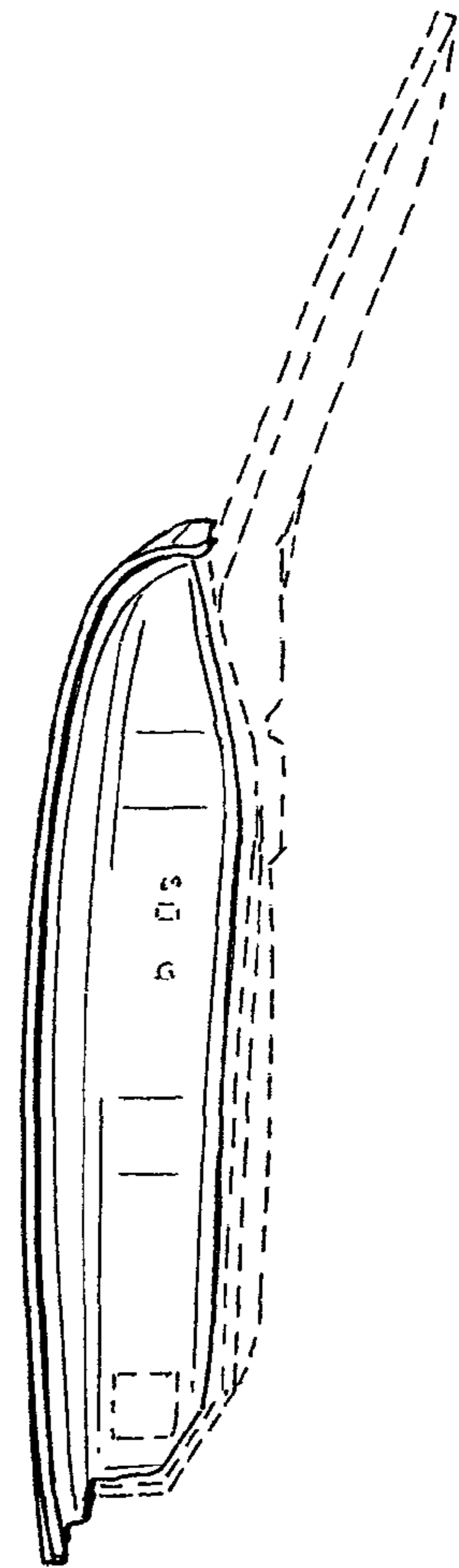

FIG. 4

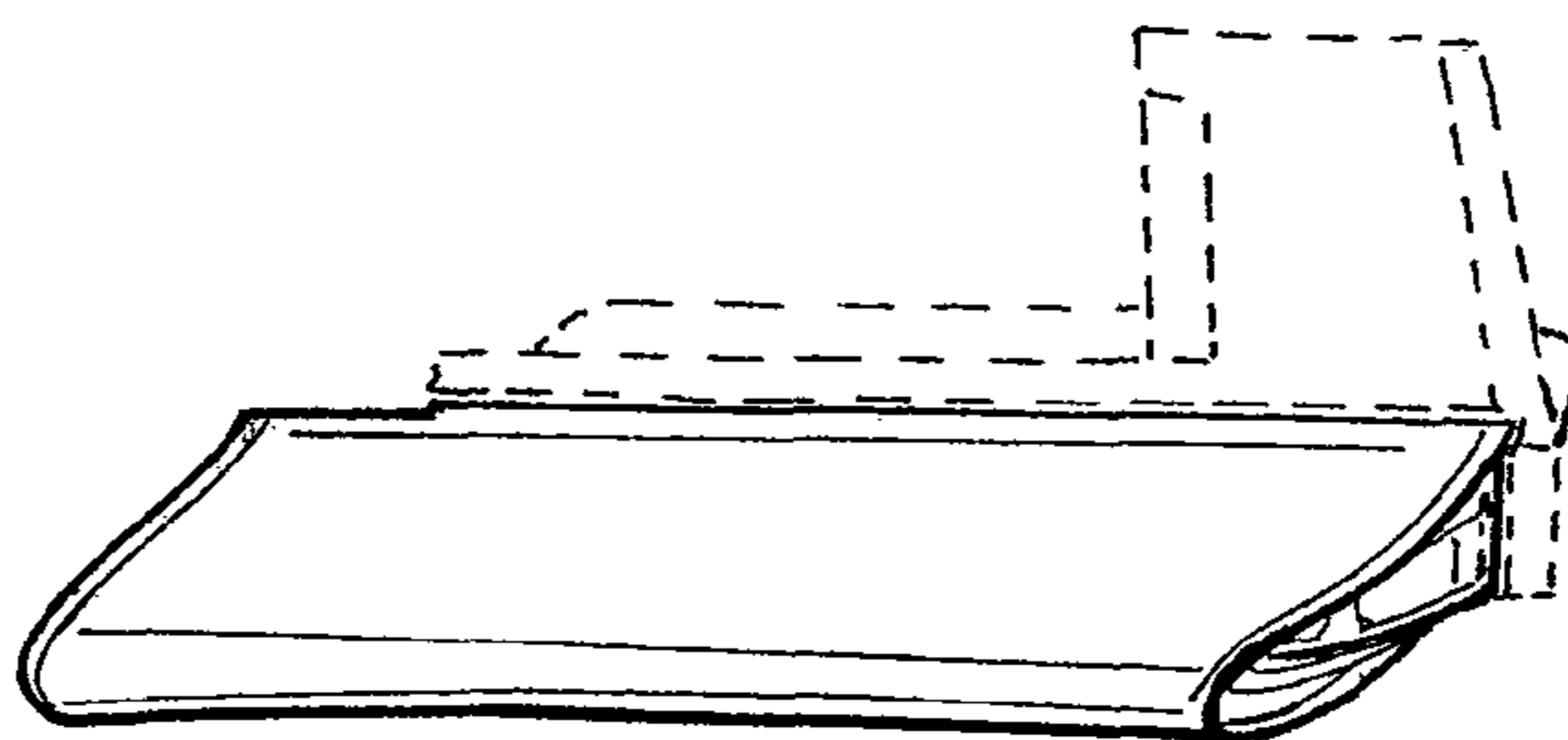

FIG. 5

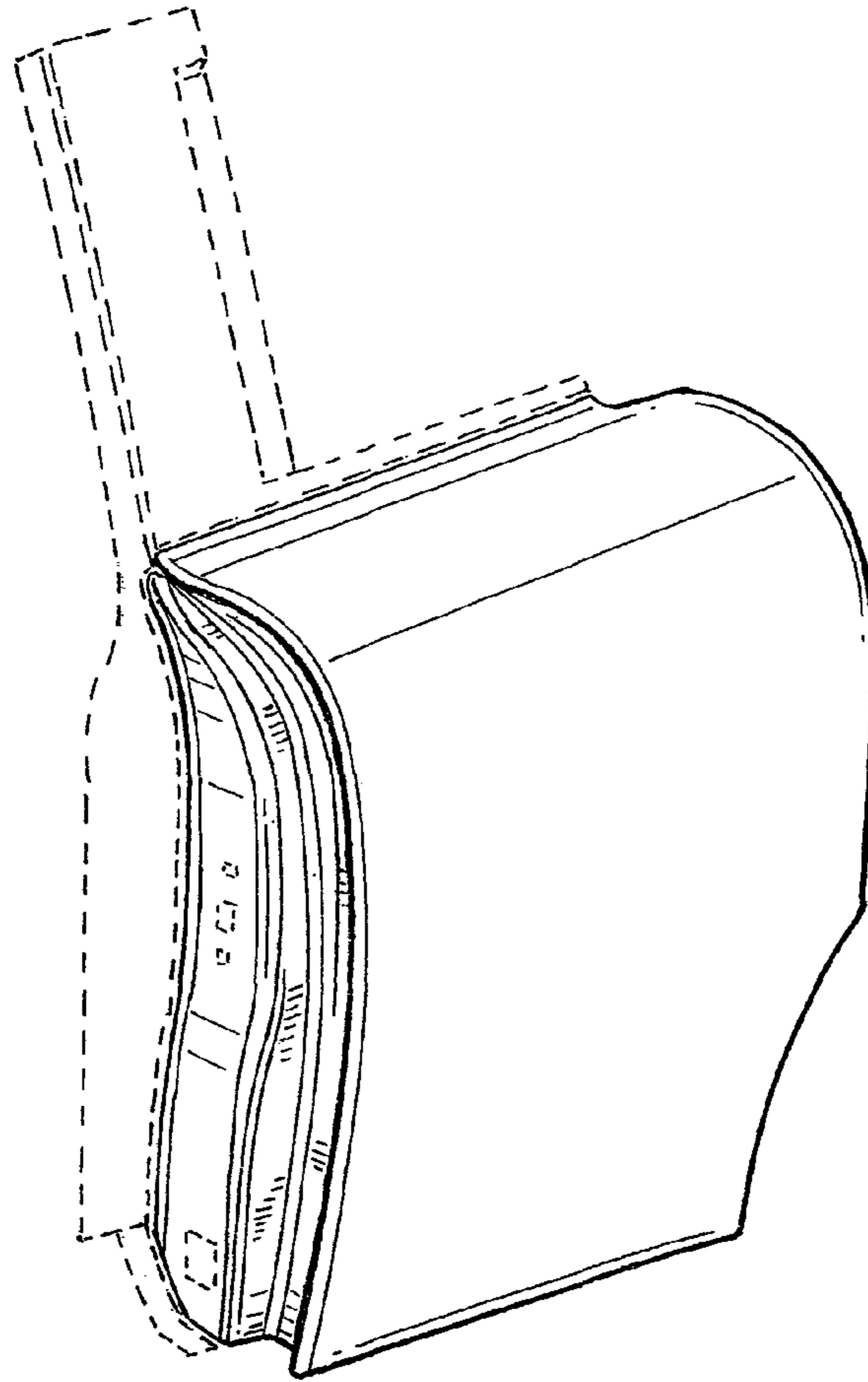

FIG. 6

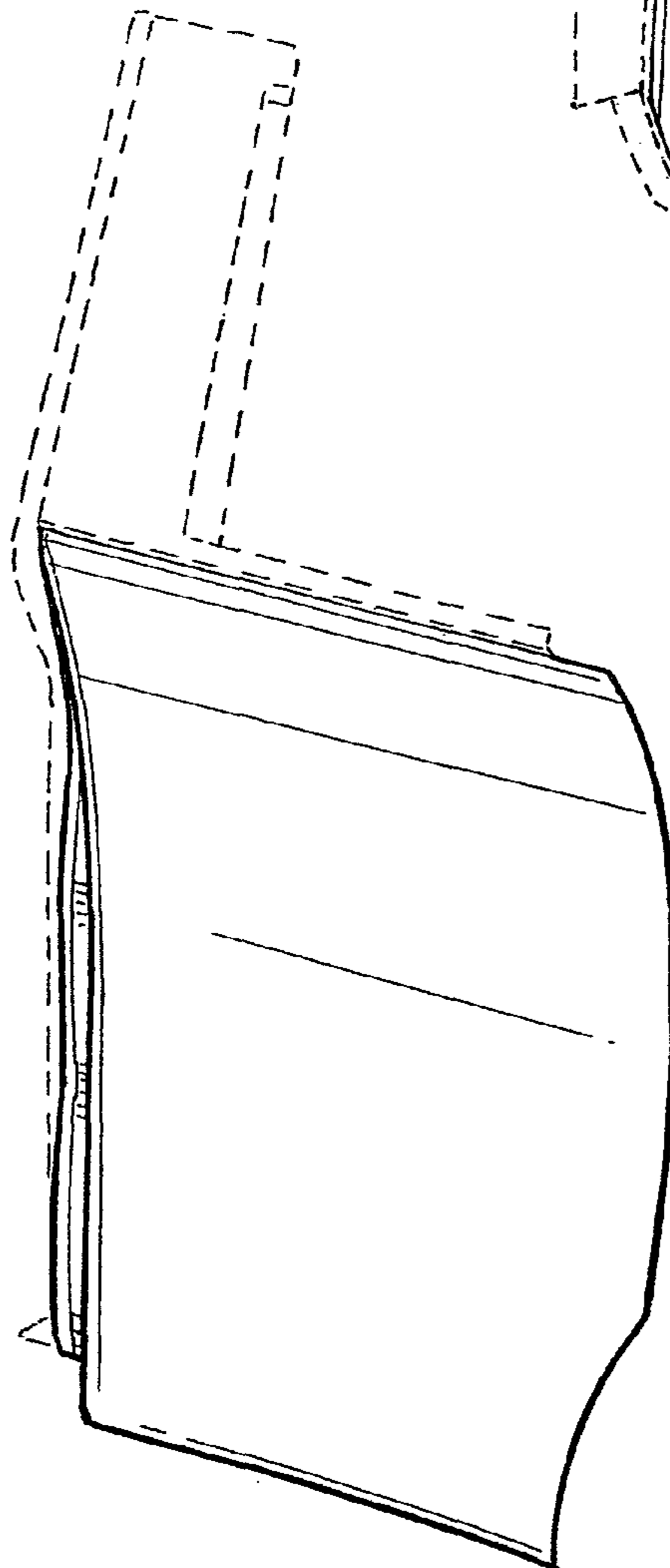

FIG. 7

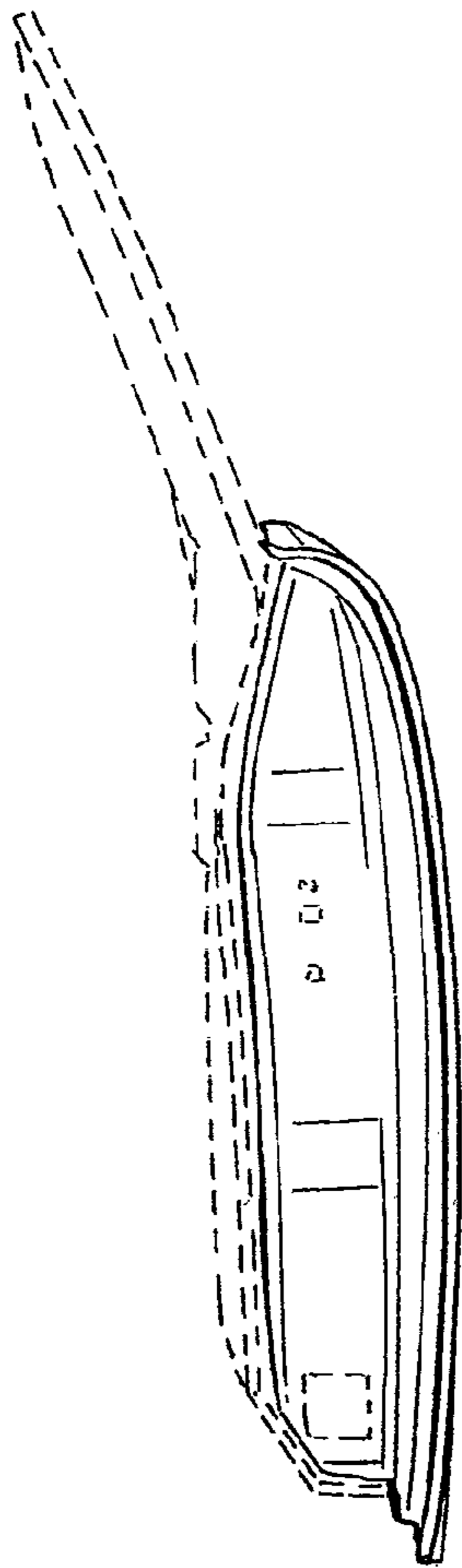

FIG. 8

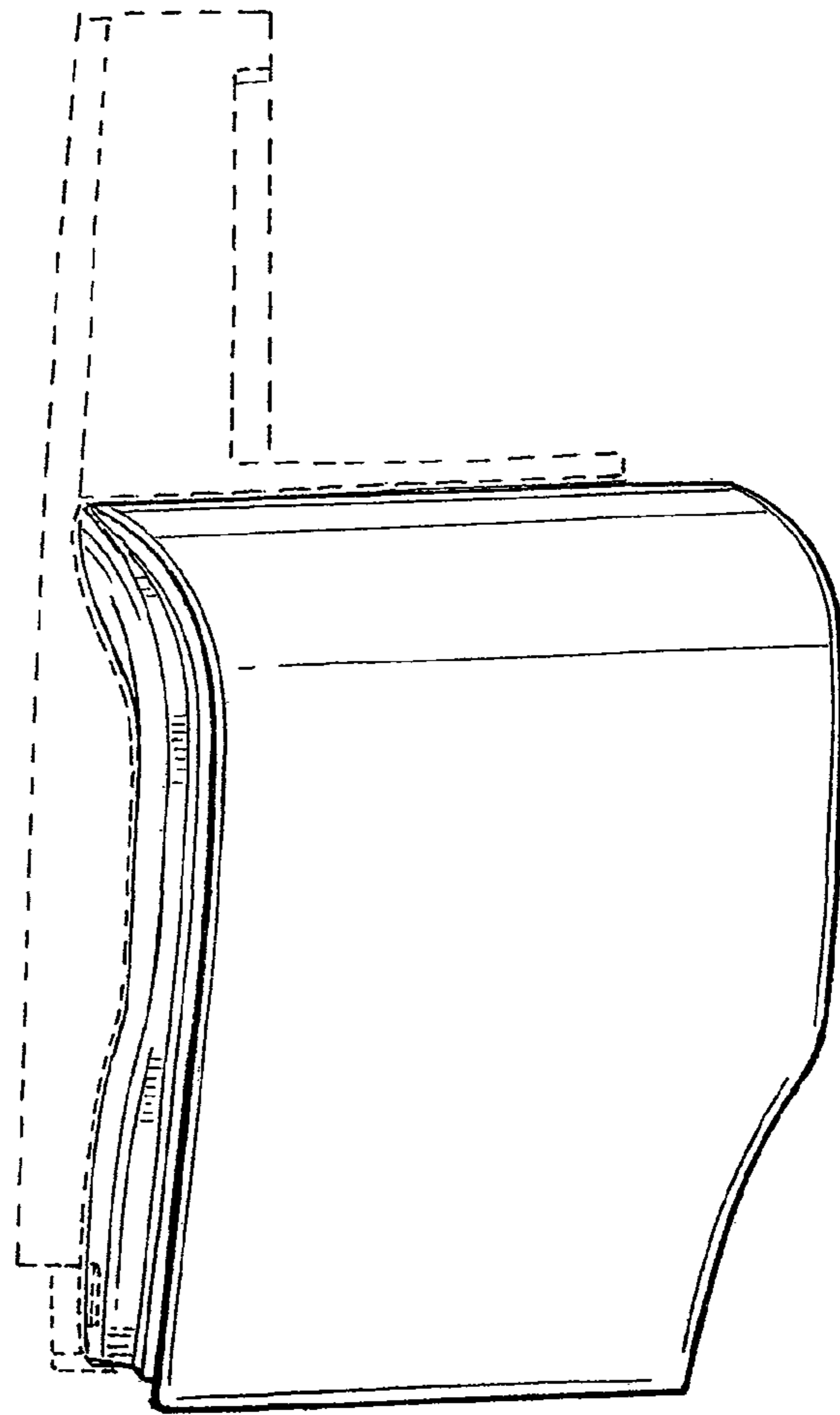

FIG. 9

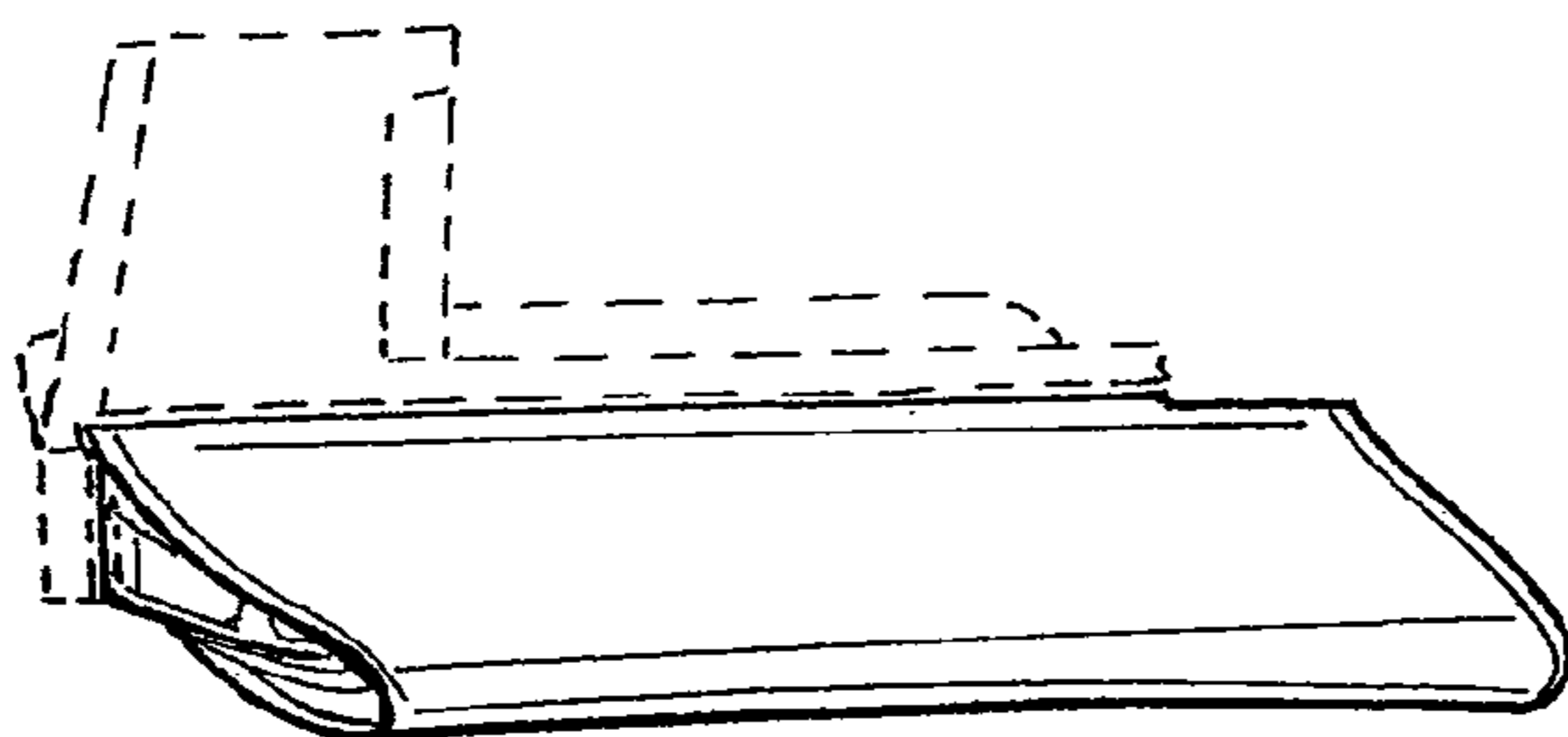

FIG. 10