



US00D612604S

(12) **United States Design Patent**  
**Horiyama et al.**

(10) **Patent No.:** **US D612,604 S**  
(45) **Date of Patent:** **\*\* Mar. 30, 2010**

- (54) **PLASTIC CASE**
- (75) Inventors: **Toru Horiyama**, Anjo (JP); **Shinsuke Okuda**, Anjo (JP)
- (73) Assignee: **Makita Corporation**, Anjo-shi (JP)
- (\*\*) Term: **14 Years**
- (21) Appl. No.: **29/344,166**
- (22) Filed: **Sep. 24, 2009**

- D413,203 S 8/1999 Zurwelle et al.
- D417,781 S 12/1999 Staheli
- D419,297 S 1/2000 Richardson et al.
- D419,768 S 2/2000 Richardson et al.
- D428,254 S 7/2000 Alexander-Katz
- D429,884 S 8/2000 Zurwelle et al.
- D432,304 S 10/2000 Zurwelle et al.
- D448,167 S 9/2001 Pangerc et al.
- D462,519 S 9/2002 Gaydos et al.
- D516,310 S 3/2006 Brunson et al.
- D516,808 S 3/2006 Brunson et al.
- 7,494,011 B2 2/2009 Henssler et al.

**Related U.S. Application Data**

- (62) Division of application No. 29/311,077, filed on Dec. 18, 2008.

**Foreign Application Priority Data**

- (30) Jun. 23, 2008 (JP) ..... D2008-015994
- Jun. 23, 2008 (JP) ..... D2008-015995
- Jun. 23, 2008 (JP) ..... D2008-015996

- (51) **LOC (9) Cl.** ..... **03-01**
- (52) **U.S. Cl.** ..... **D3/281; D3/294; D3/905**
- (58) **Field of Classification Search** ..... **D3/272-273, D3/276, 279-282, 291, 294-295, 905; 206/349, 206/372-373, 503, 508**  
See application file for complete search history.

**References Cited**

**U.S. PATENT DOCUMENTS**

- D234,273 S 2/1975 Wilson et al.
- D294,775 S 3/1988 Rechberg
- 4,743,038 A 5/1988 Myers et al.
- D385,109 S 10/1997 Staheli
- D402,462 S 12/1998 Sanderson

**FOREIGN PATENT DOCUMENTS**

- JP S-1268221 3/2006

*Primary Examiner*—Philip S Hyder  
*Assistant Examiner*—RoseLynne Cody  
 (74) *Attorney, Agent, or Firm*—Oliff & Berridge, PLC

(57) **CLAIM**

The ornamental design for a plastic case, as shown and described.

**DESCRIPTION**

FIG. 1 is a perspective view of a plastic case showing our new design;  
 FIG. 2 is a front elevation view thereof;  
 FIG. 3 is a rear elevation view thereof;  
 FIG. 4 is a left side elevation view thereof;  
 FIG. 5 is a right side elevation view thereof;  
 FIG. 6 is a top plan view thereof; and,  
 FIG. 7 is a bottom plan view thereof.

**1 Claim, 4 Drawing Sheets**

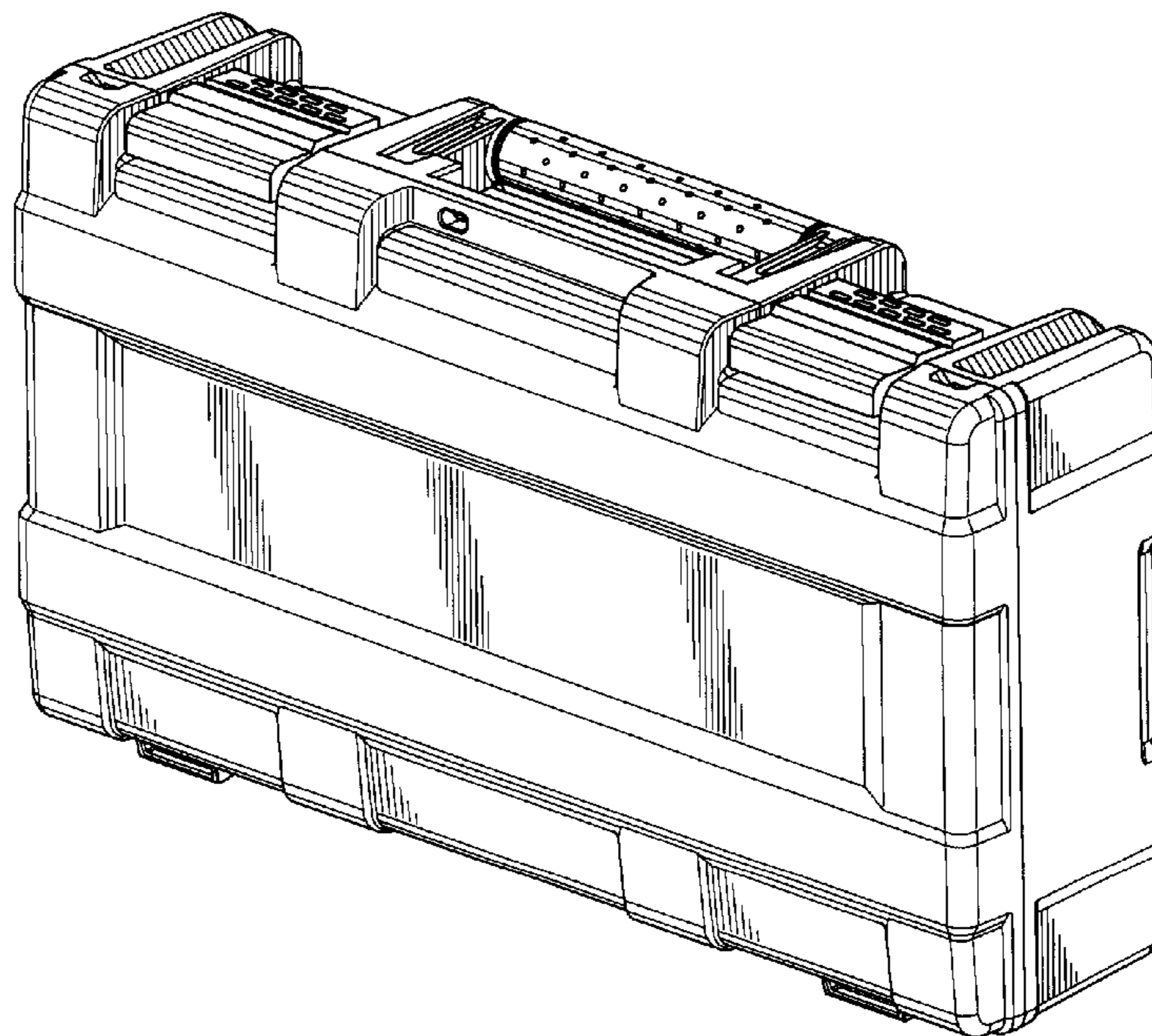

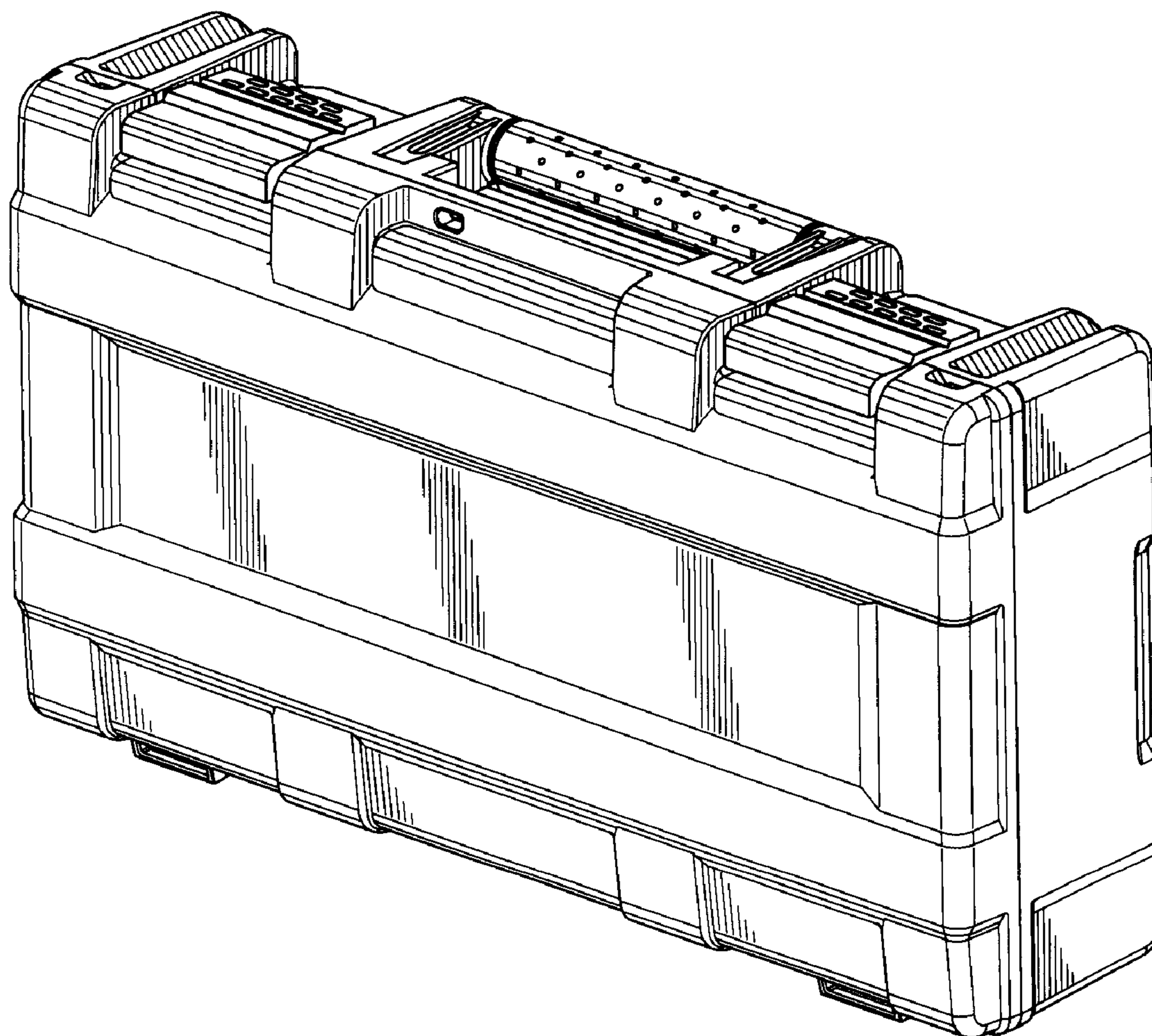

FIG. 1



FIG. 2

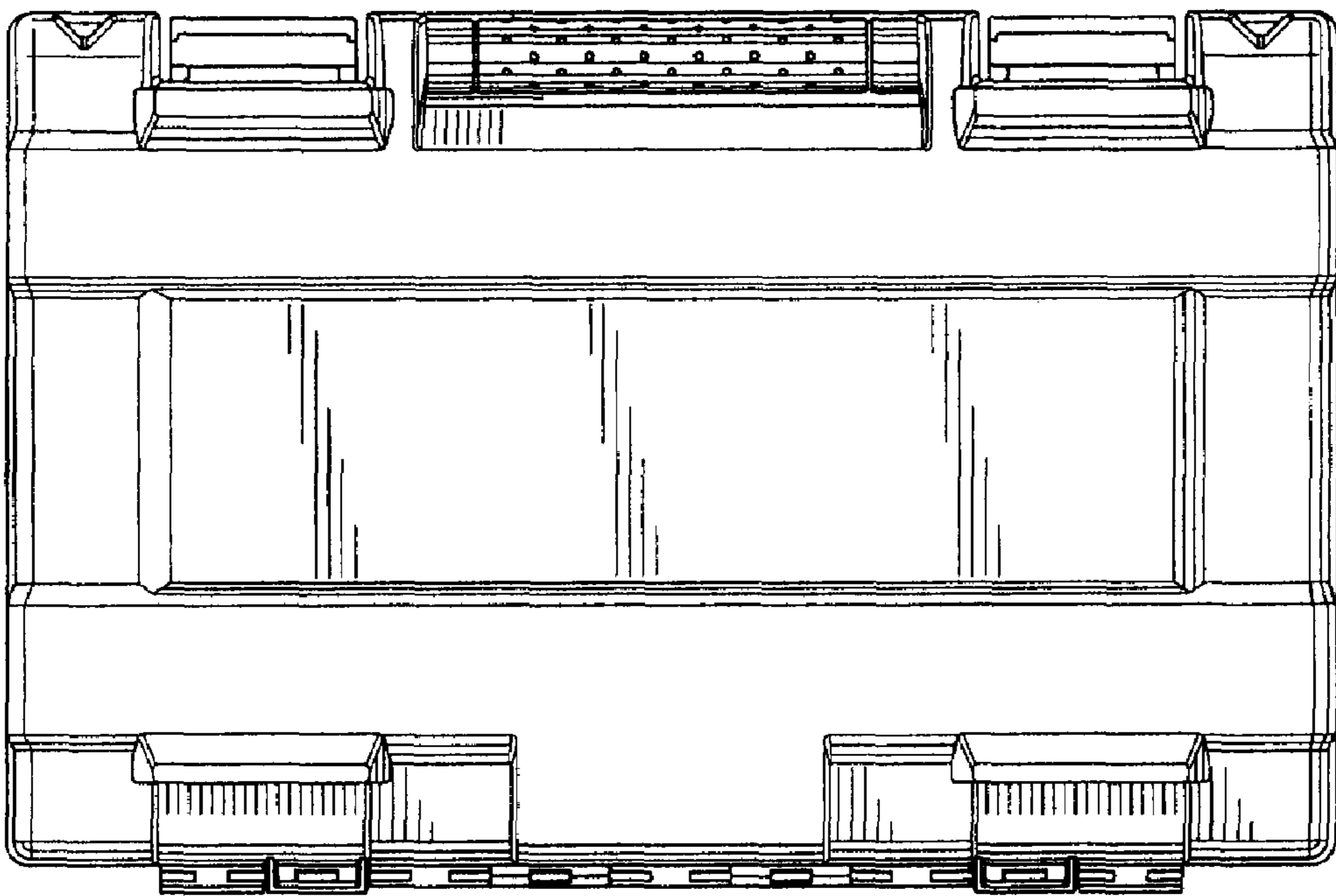

FIG. 3

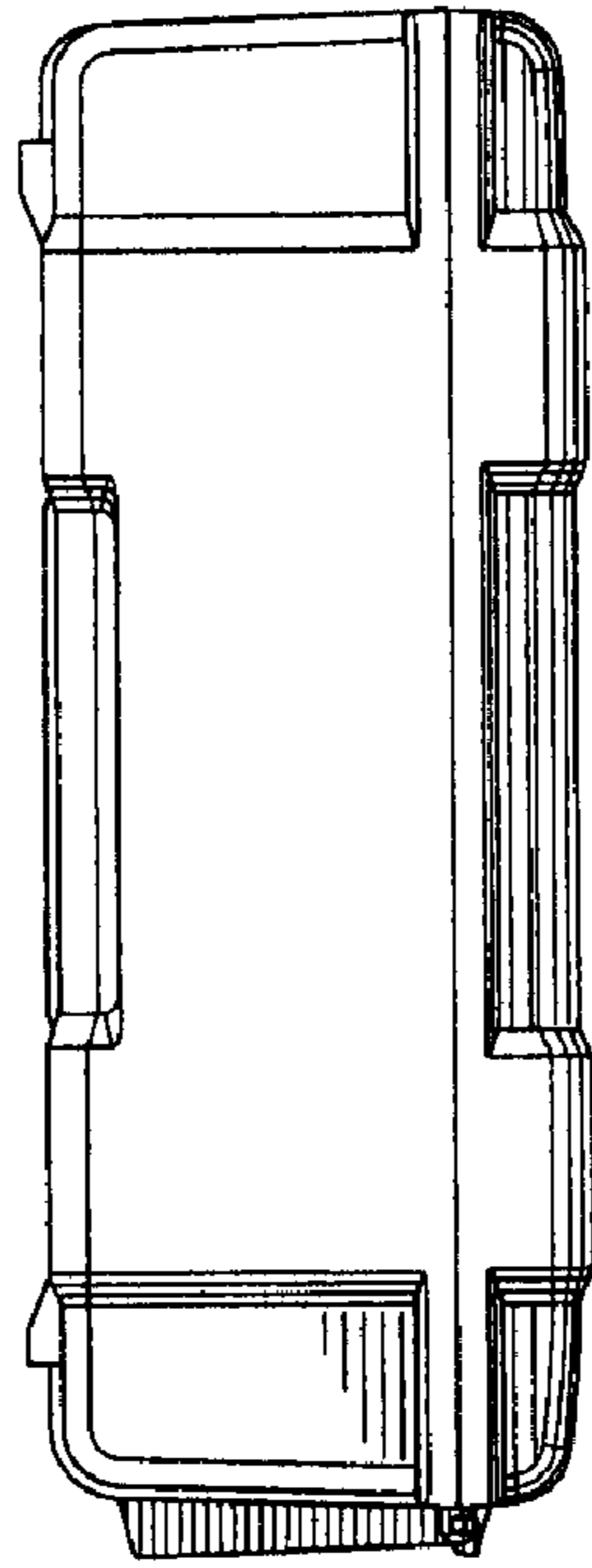

FIG. 4

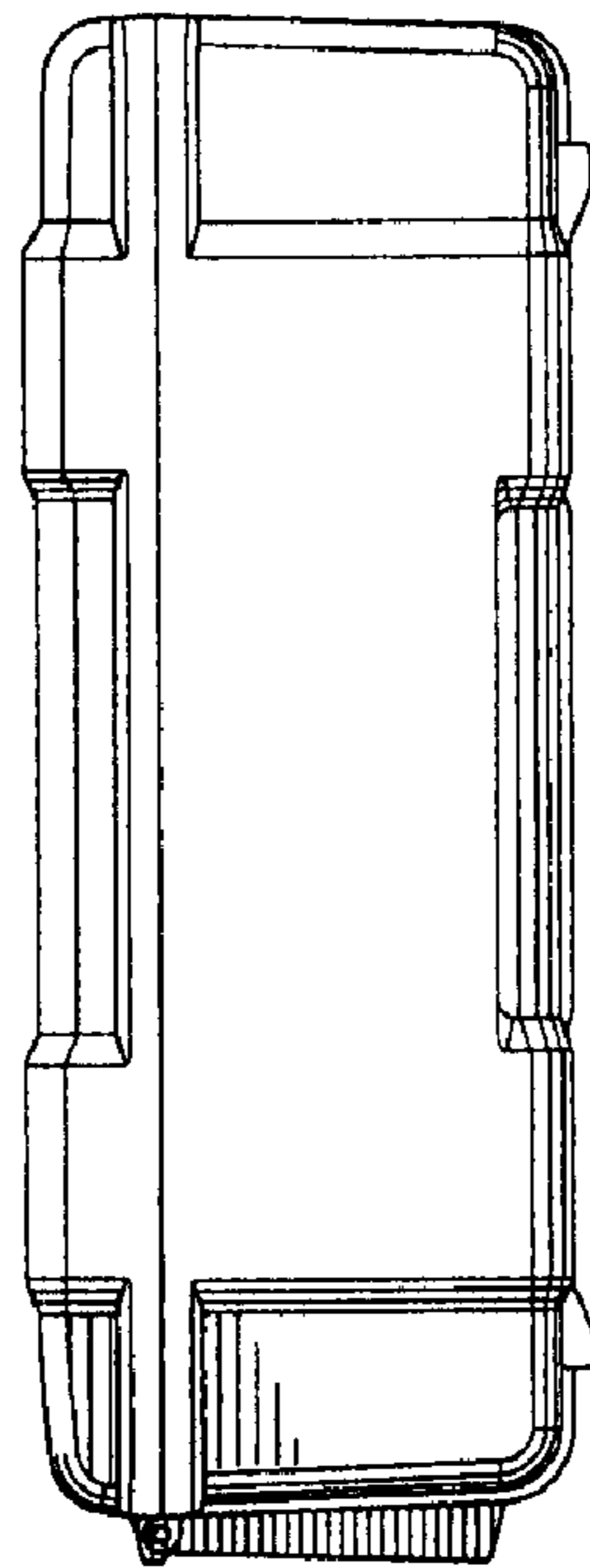

FIG. 5

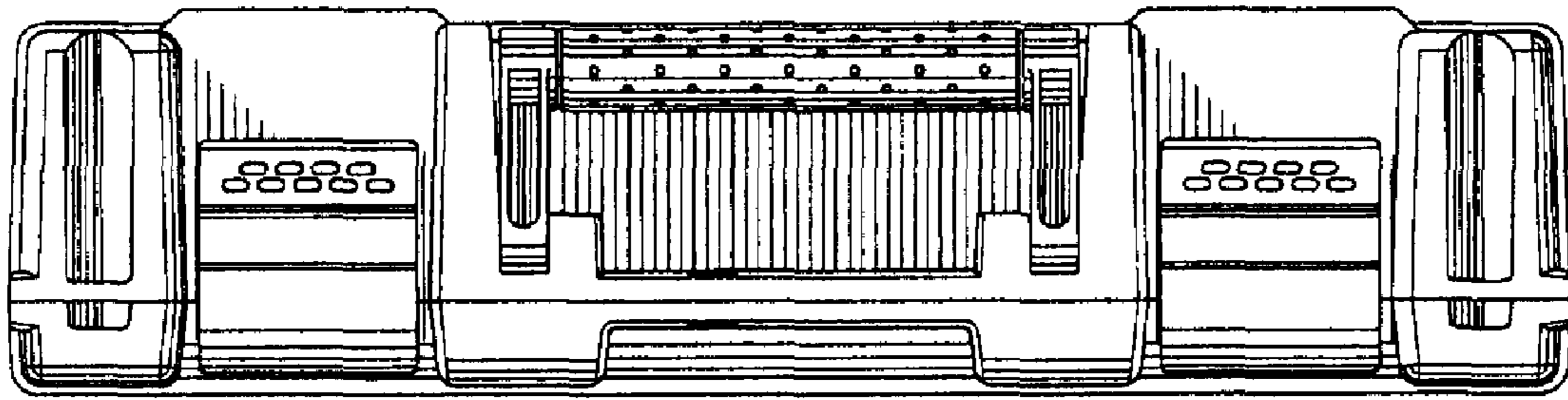

FIG. 6

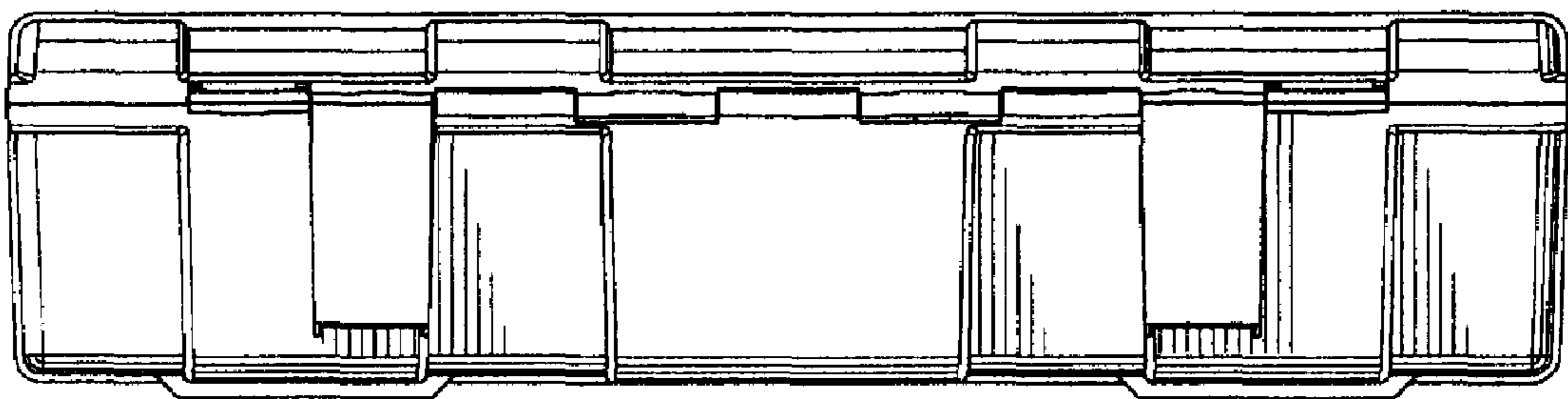

FIG. 7