



US00D612598S

(12) **United States Design Patent**  
**Shabi**

(10) **Patent No.:** **US D612,598 S**

(45) **Date of Patent:** **\*\* \*Mar. 30, 2010**

(54) **HANDBAG**

(75) Inventor: **Yaniv Shabi**, Forest Hills, NY (US)

(73) Assignee: **Tomgal, LLC**, Pompano Beach, FL (US)

(\*) Notice: This patent is subject to a terminal disclaimer.

(\*\*) Term: **14 Years**

(21) Appl. No.: **29/331,305**

(22) Filed: **Jan. 23, 2009**

(51) **LOC (9) Cl.** ..... **03-01**

(52) **U.S. Cl.** ..... **D3/234**

(58) **Field of Classification Search** ..... D3/232–234,  
D3/238, 240–246, 318, 324; 150/100, 103–104,  
150/106–110, 113–114, 118–119

See application file for complete search history.

(56) **References Cited**

U.S. PATENT DOCUMENTS

D244,914 S \* 7/1977 Nicol ..... D9/704  
D453,070 S \* 1/2002 Jacobs ..... D3/234

\* cited by examiner

*Primary Examiner*—Holly H Baynham

(74) *Attorney, Agent, or Firm*—Jon A. Gibbons; Fleit,  
Gibbons, Gutman, Bongini & Bianco P.L.

(57) **CLAIM**

The ornamental design for a handbag, as shown and described.

**DESCRIPTION**

FIG. 1 is a top plan view of a first embodiment of a handbag with the state of Alaska, showing our new design;

FIG. 2 is a top plan view of a second embodiment of a handbag with the state of Arizona, showing our new design;

FIG. 3 is a top plan view of a third embodiment of a handbag with the city of Atlanta, showing our new design;

FIG. 4 is a top plan view of a fourth embodiment of a handbag with the city of Atlantic City, showing our new design;

FIG. 5 is a top plan view of a fifth embodiment of a handbag with the city of Boston, showing our new design;

FIG. 6 is a top plan view of a sixth embodiment of a handbag with the state of California, showing our new design;

FIG. 7 is a top plan view of a first embodiment of a handbag with the city of Dallas, showing our new design;

FIG. 8 is a top plan view of a second embodiment of a handbag with the city of Hudson, showing our new design;

FIG. 9 is a top plan view of a third embodiment of a handbag with the city of Kansas City, showing our new design;

FIG. 10 is a top plan view of a fourth embodiment of a handbag with the state of Kentucky, showing our new design;

FIG. 11 is a top plan view of a fifth embodiment of a handbag with the city of Memphis, showing our new design;

FIG. 12 is a top plan view of a sixth embodiment of a handbag with the city of Myrtle Beach, showing our new design;

FIG. 13 is a top plan view of a sixth embodiment of a handbag with the city of Nashville, showing our new design.

FIG. 14 is a top plan view of a first embodiment of a handbag with the state of North Carolina, showing our new design;

FIG. 15 is a top plan view of a second embodiment of a handbag with the state of Ohio, showing our new design;

FIG. 16 is a top plan view of a third embodiment of a handbag with the territory of Puerto Rico, showing our new design;

FIG. 17 is a top plan view of a fourth embodiment of a handbag with the city of San Diego, showing our new design;

FIG. 18 is a top plan view of a fifth embodiment of a handbag with the state of Tennessee, showing our new design; and

FIG. 19 is a top plan view of a sixth embodiment of a handbag with the state of Texas, showing our new design;

FIG. 20 is a top plan view of a sixth embodiment of a handbag with the state of Washington, showing our new design.



FIG. **21** is a top plan view of a first embodiment of a handbag with the state of New Mexico, showing our new design;

FIG. **22** is a top plan view of a second embodiment of a handbag with the state of Maryland, showing our new design;

FIG. **23** is a top plan view of a third embodiment of a handbag with the state of Colorado, showing our new design;

FIG. **24** is a top plan view of a fourth embodiment of a handbag with the city of San Jose, showing our new design;

FIG. **25** is a top plan view of a fifth embodiment of a handbag with the city of Seattle, showing our new design; and

FIG. **26** is a top plan view of a sixth embodiment of a handbag with the city Portland, showing our new design;

FIG. **27** is a top plan view of a first embodiment of a handbag with the city of Pittsburg, showing our new design;

FIG. **28** is a top plan view of a second embodiment of a handbag with the city of Phoenix, showing our new design;

FIG. **29** is a top plan view of a third embodiment of a handbag with the city of Key West, showing our new design;

FIG. **30** is a top plan view of a fourth embodiment of a handbag with the state of Maine, showing our new design; and,

FIG. **31** is a top plan view of a fifth embodiment of a handbag with the island of Maui, showing our new design.

The broken lines in FIGS. **1–31** are included for the purpose of illustrating a portion of the handbag that forms no part of the claimed design.

**1 Claim, 31 Drawing Sheets**



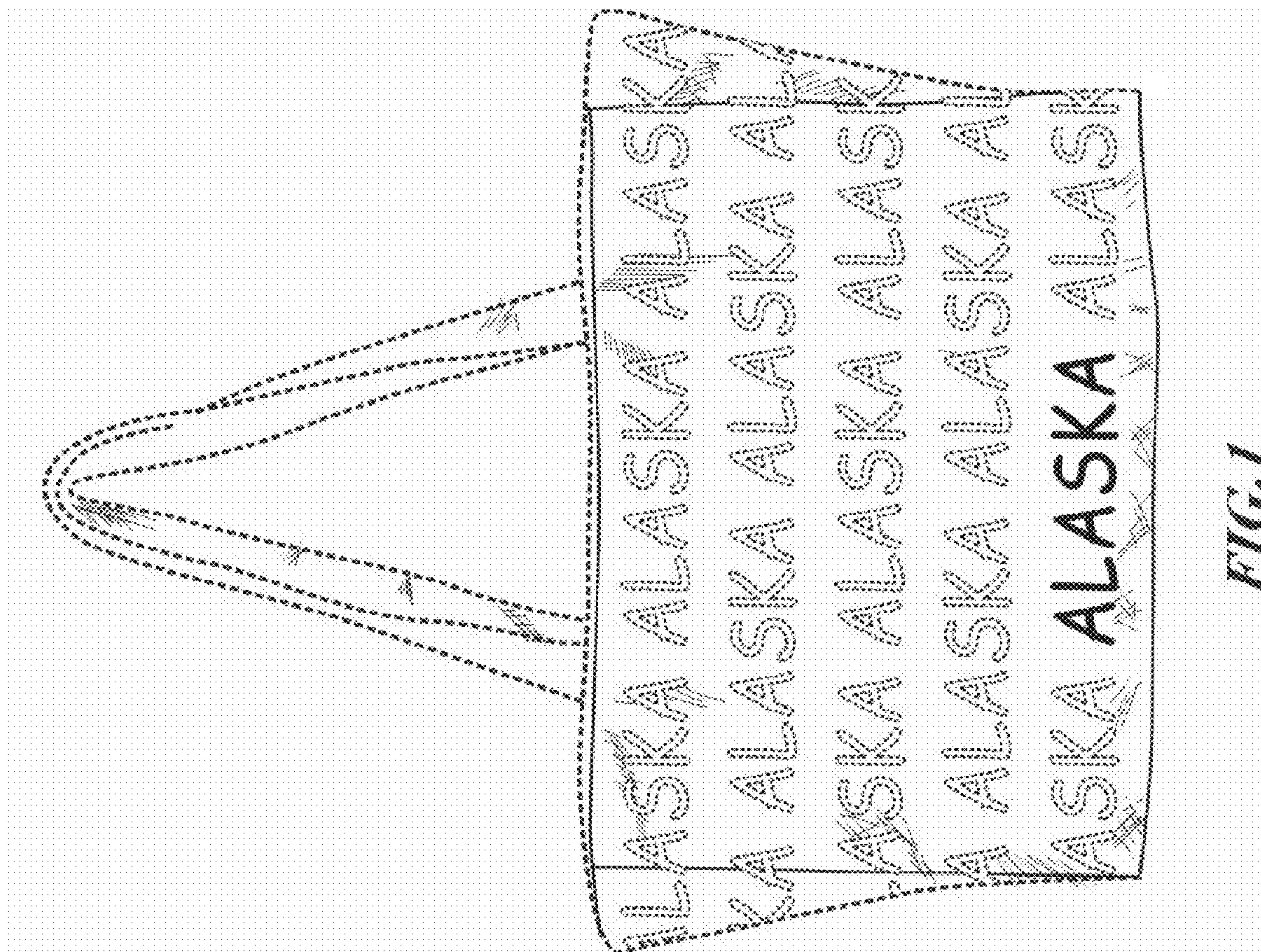

FIG. 1

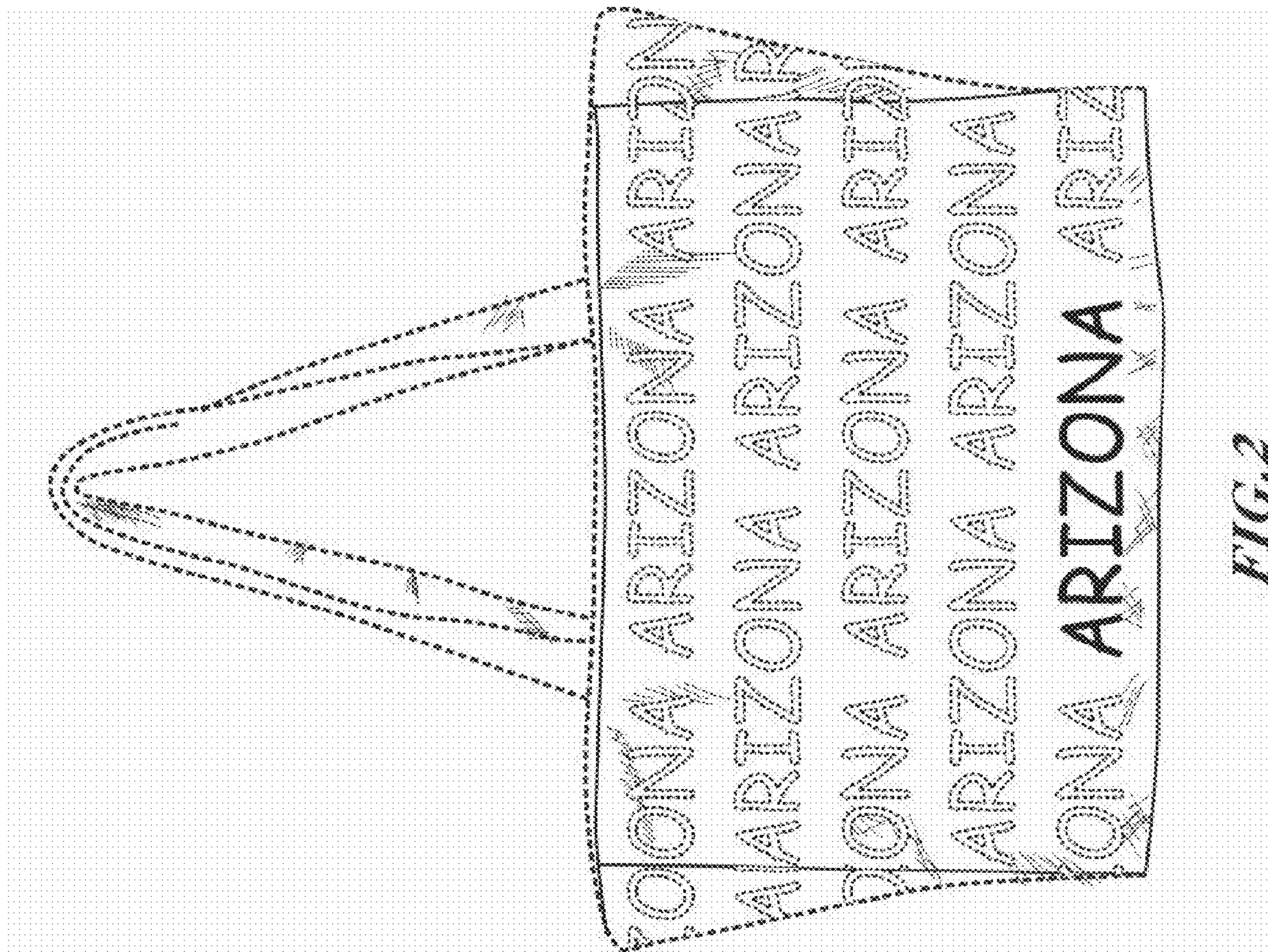

FIG. 2



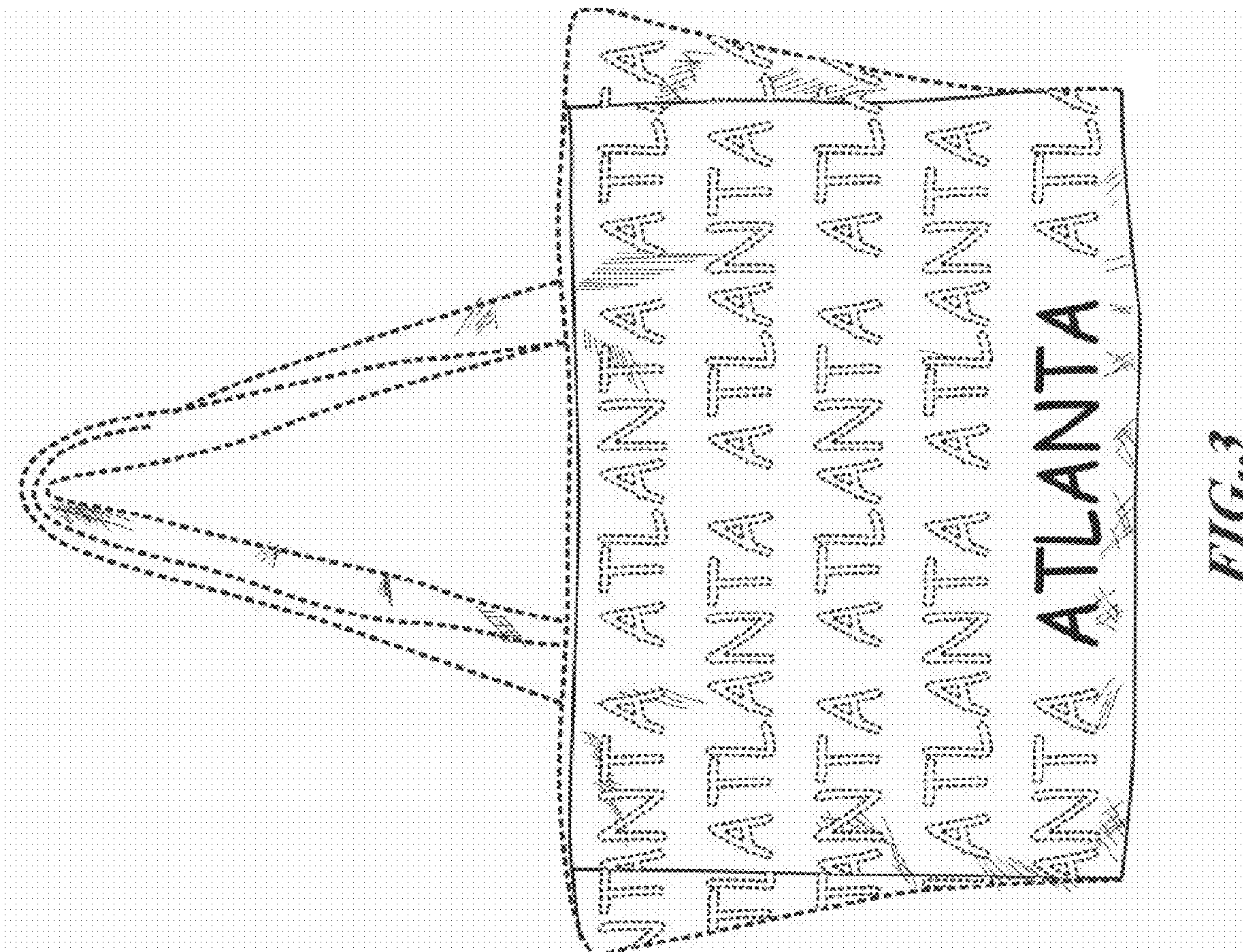

FIG. 3

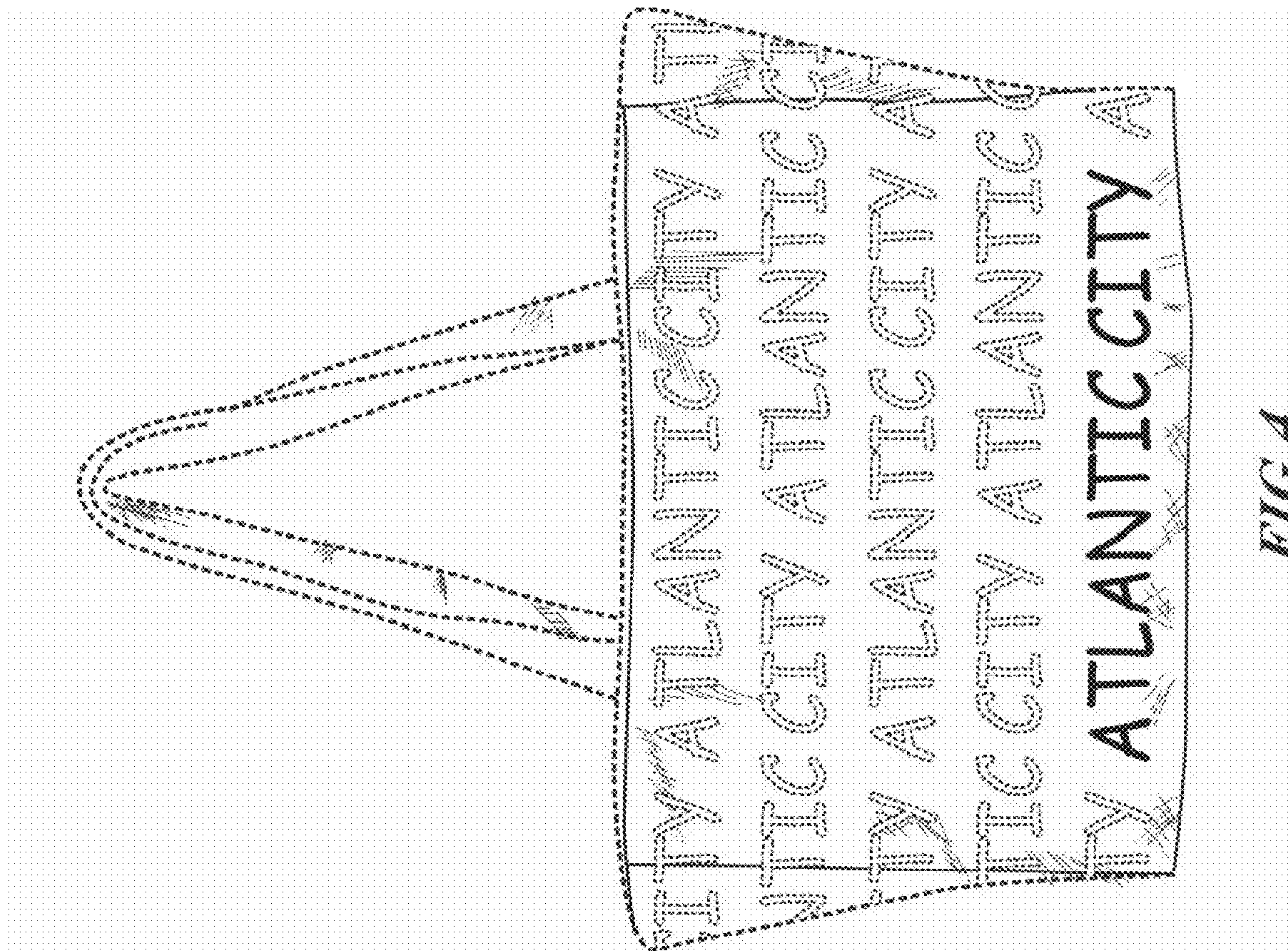
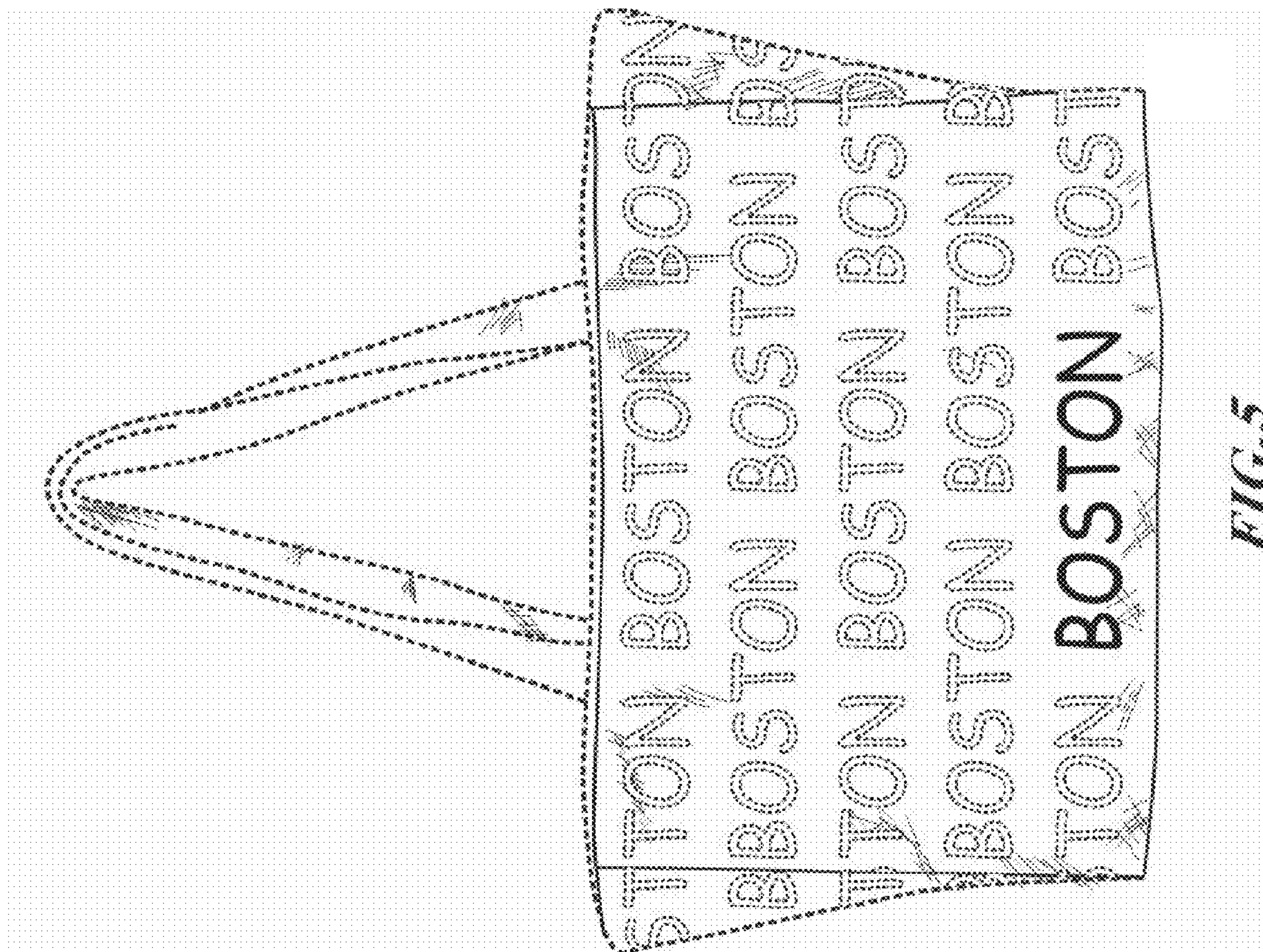

FIG. 4





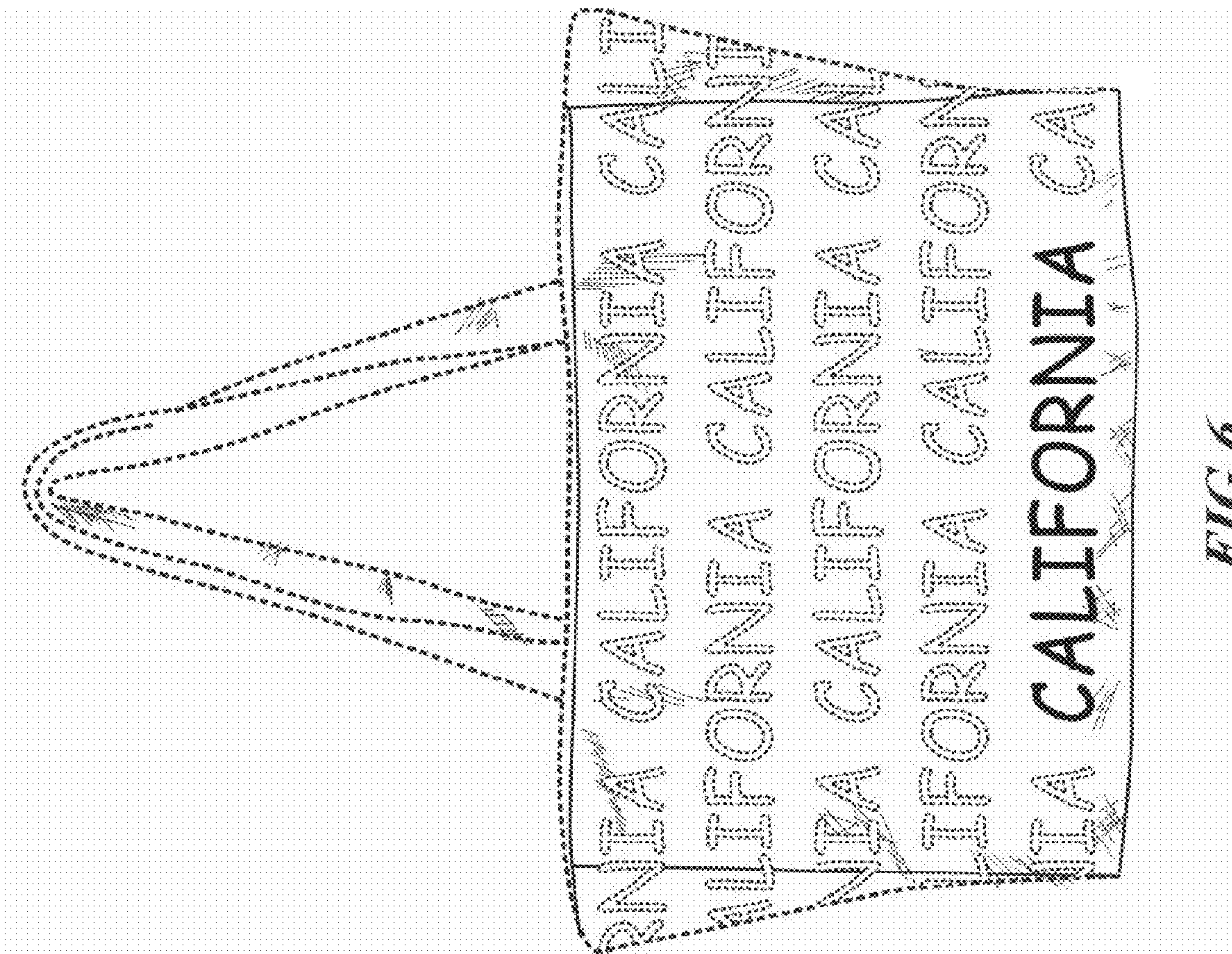

FIG. 6



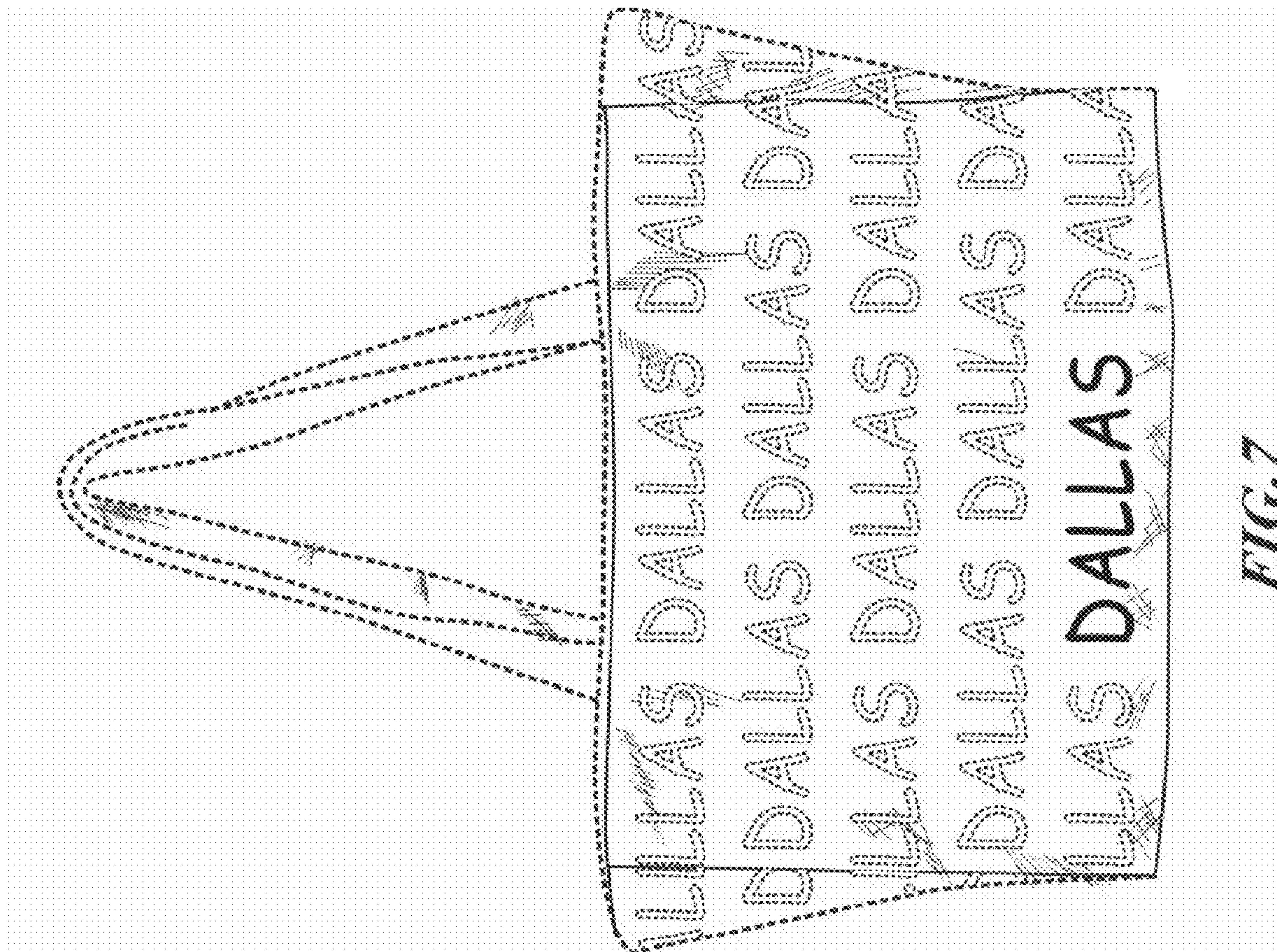

FIG. 7

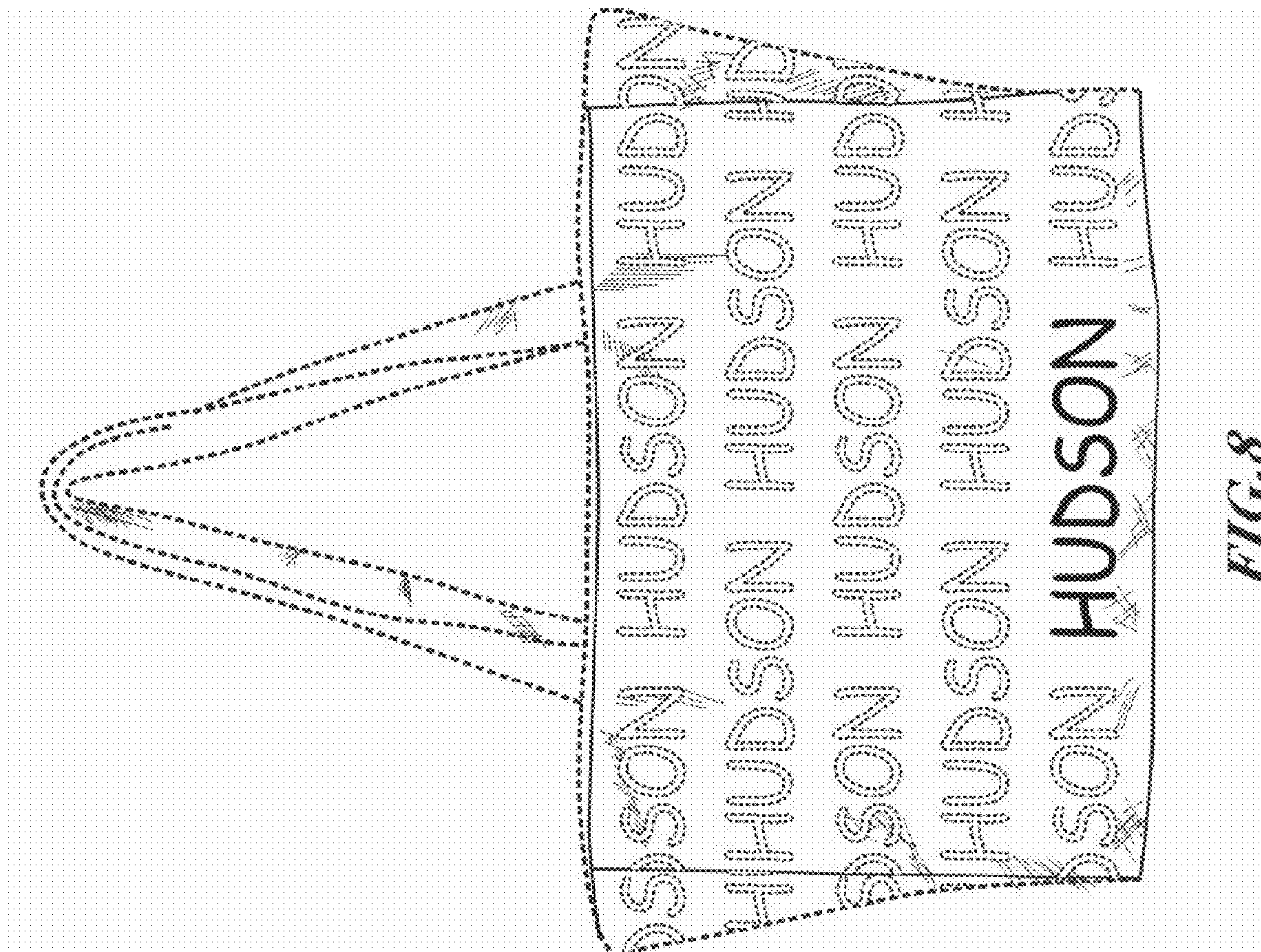

FIG. 8



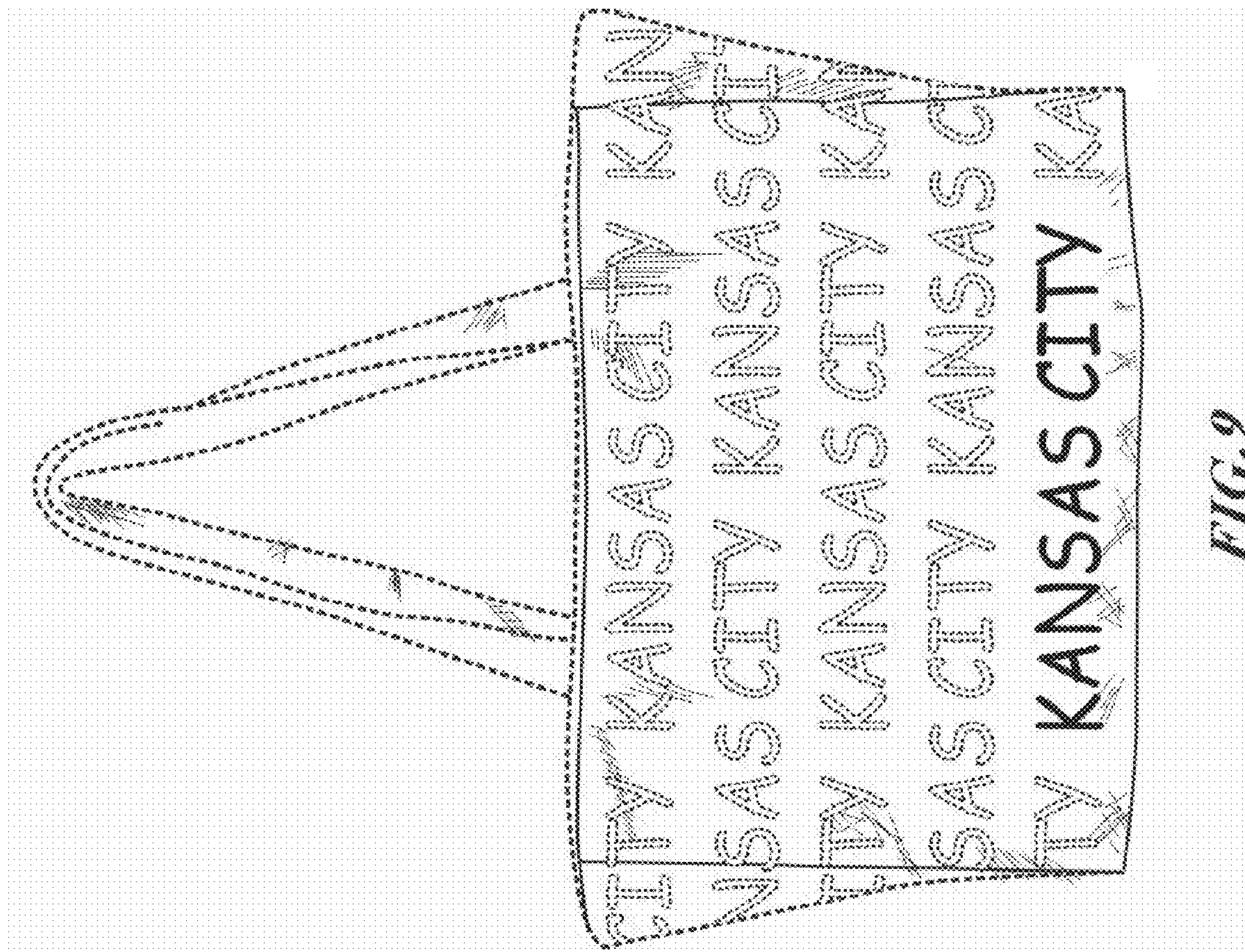

FIG. 9

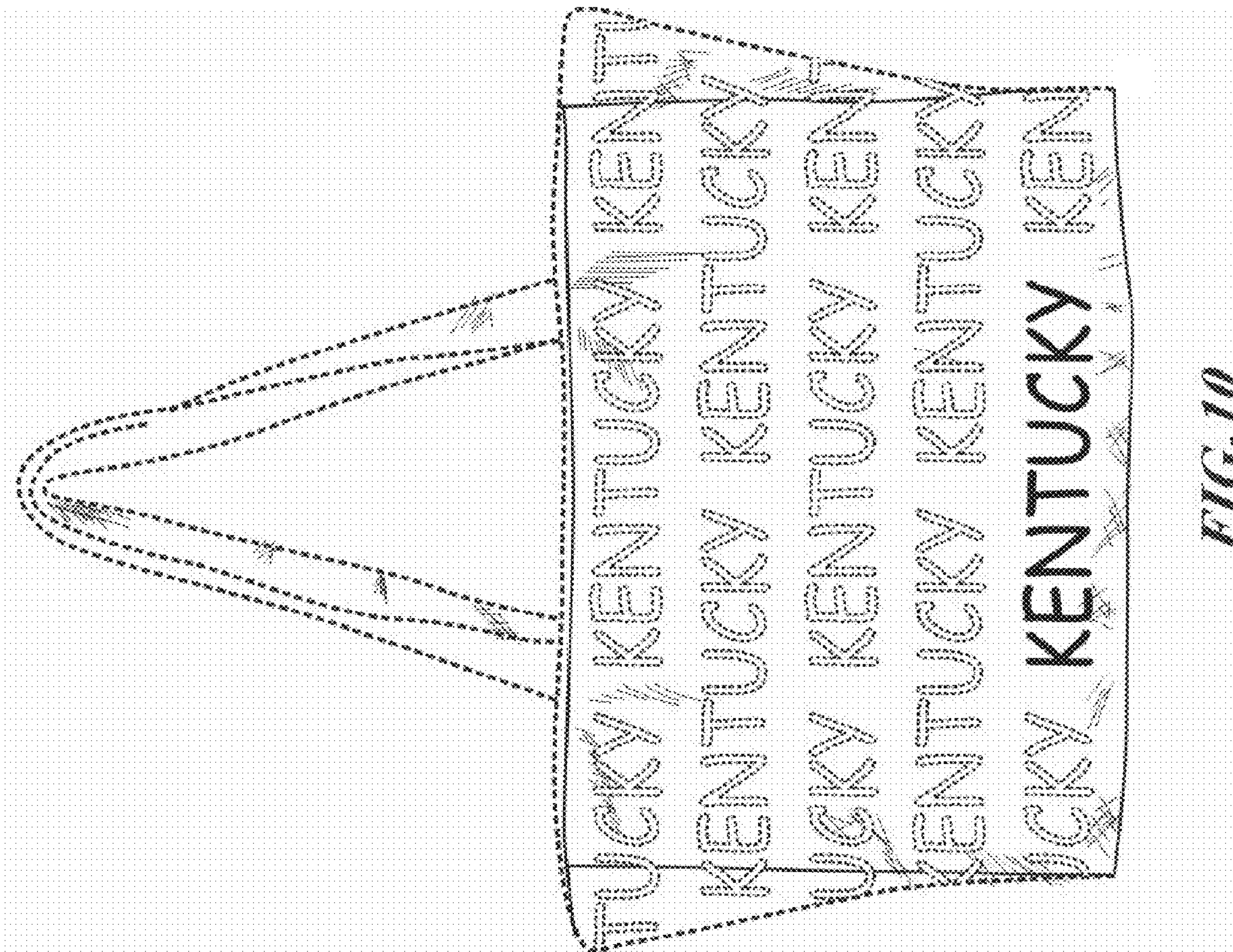

FIG. 10





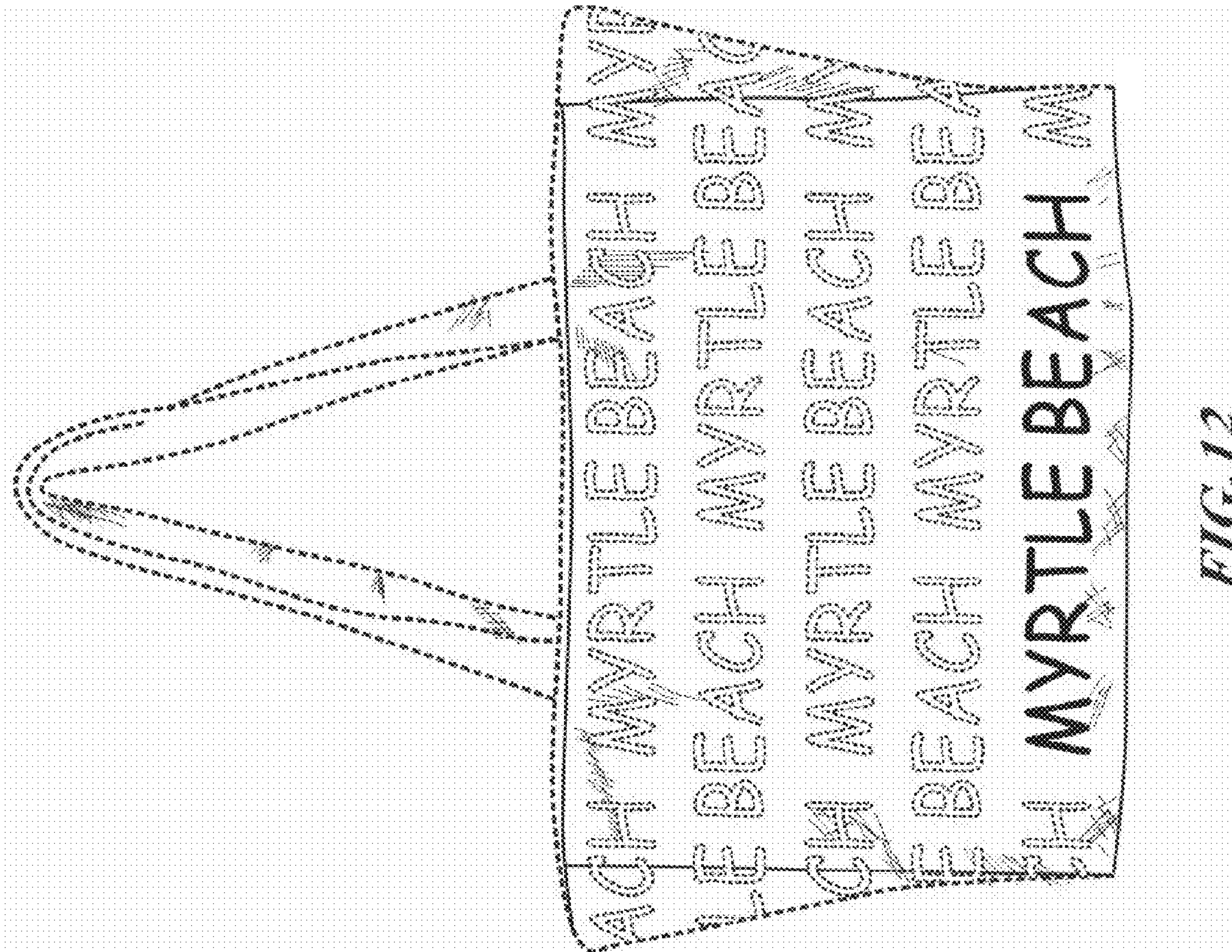

FIG. 12



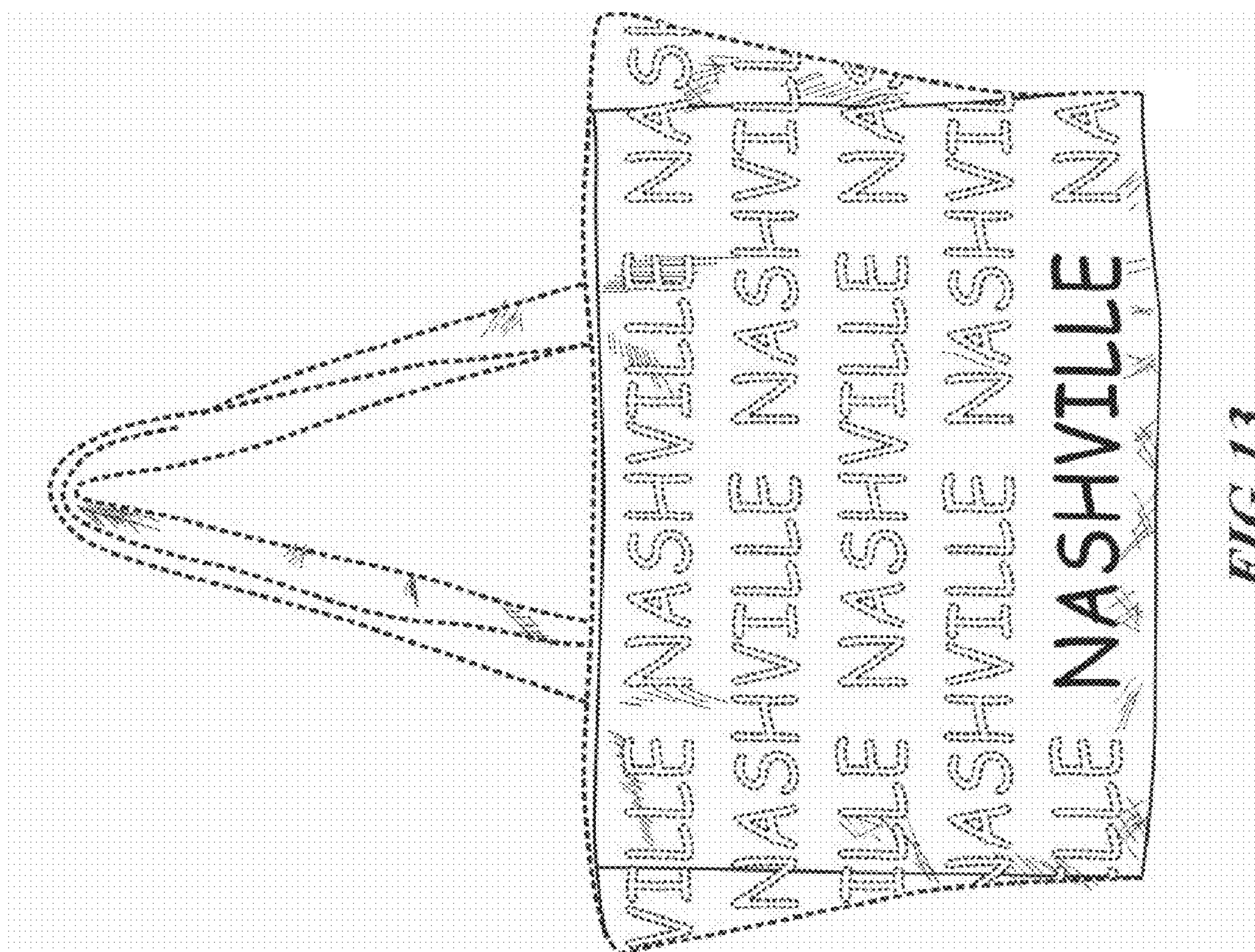

FIG. 13

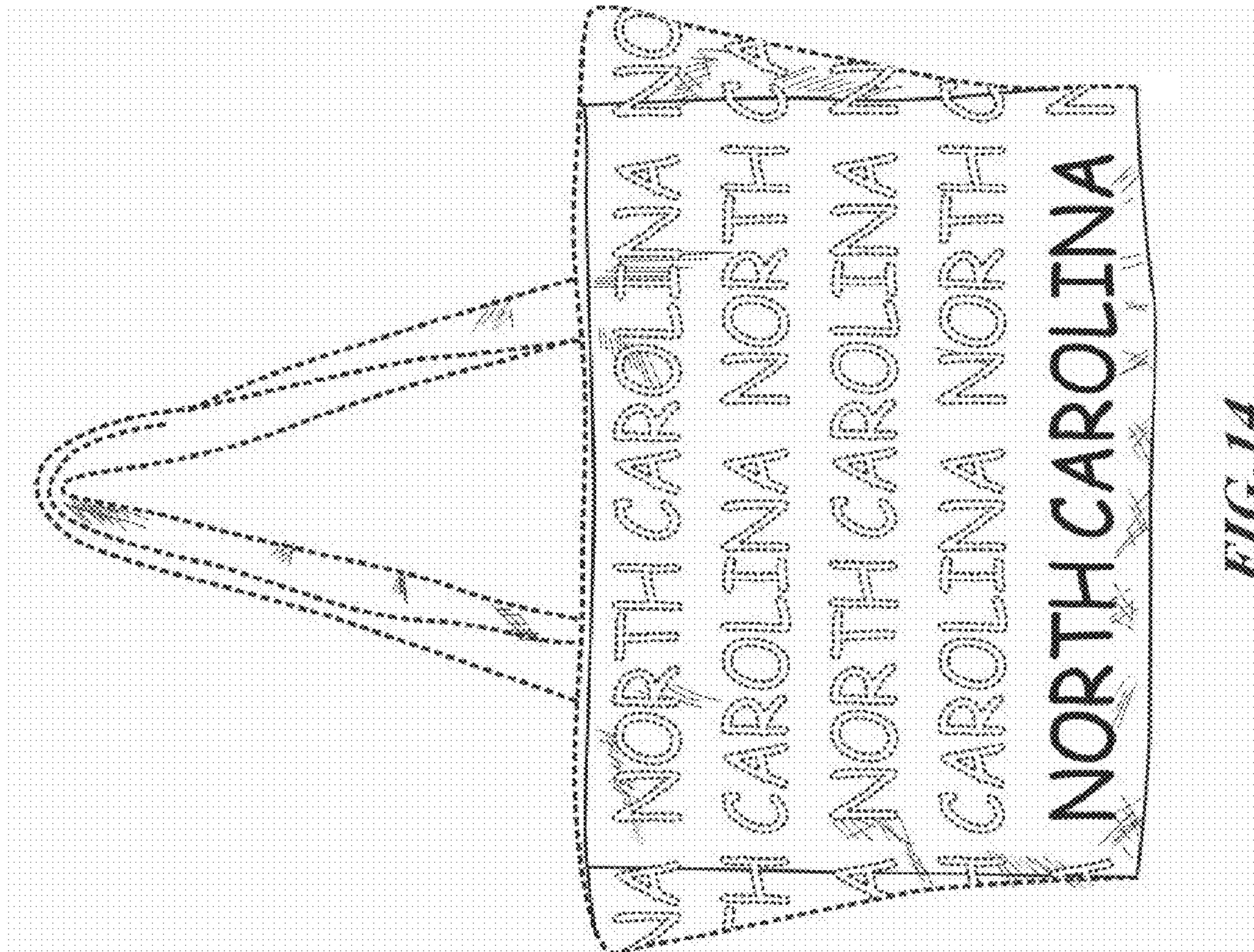

FIG. 14



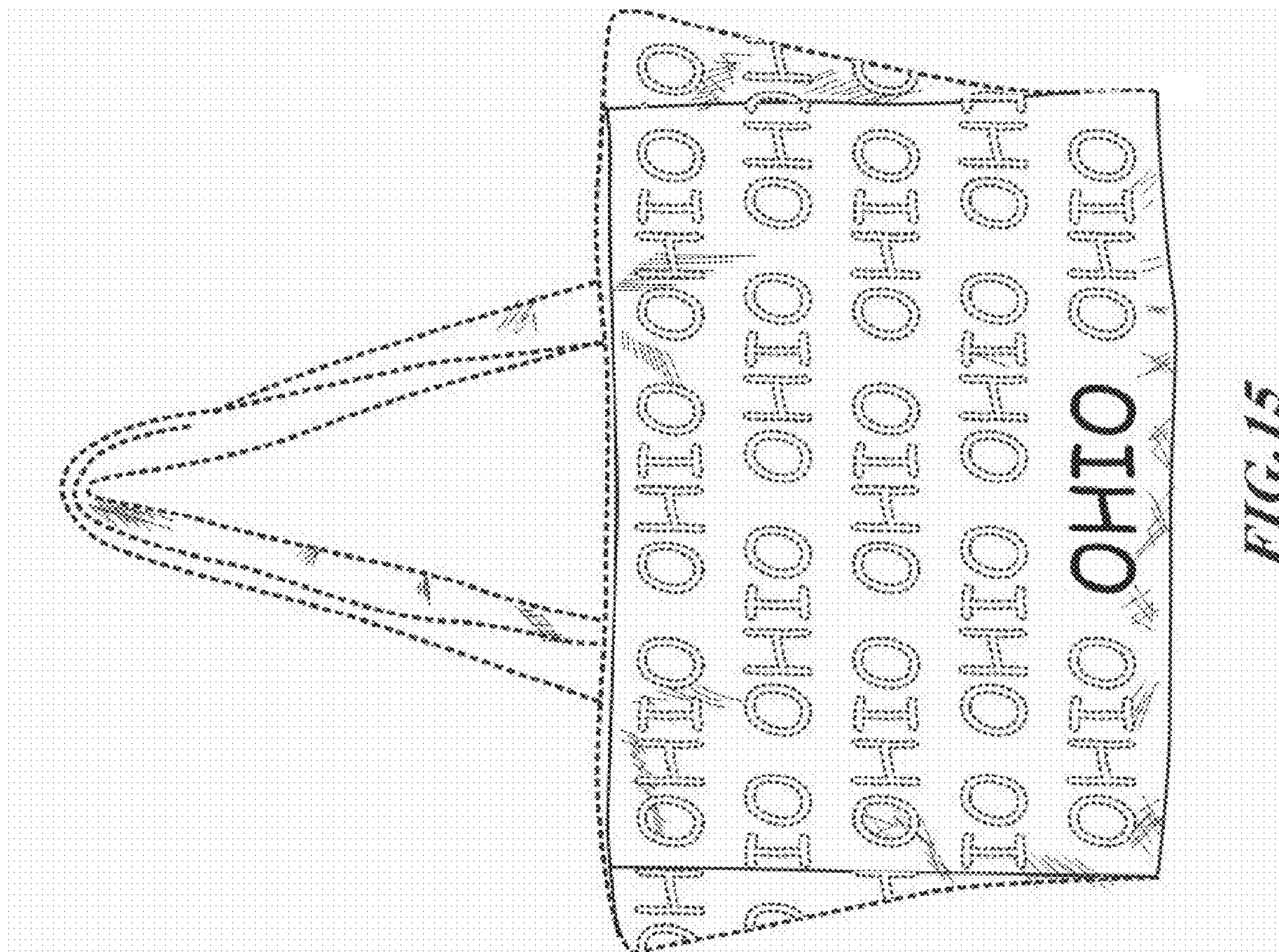
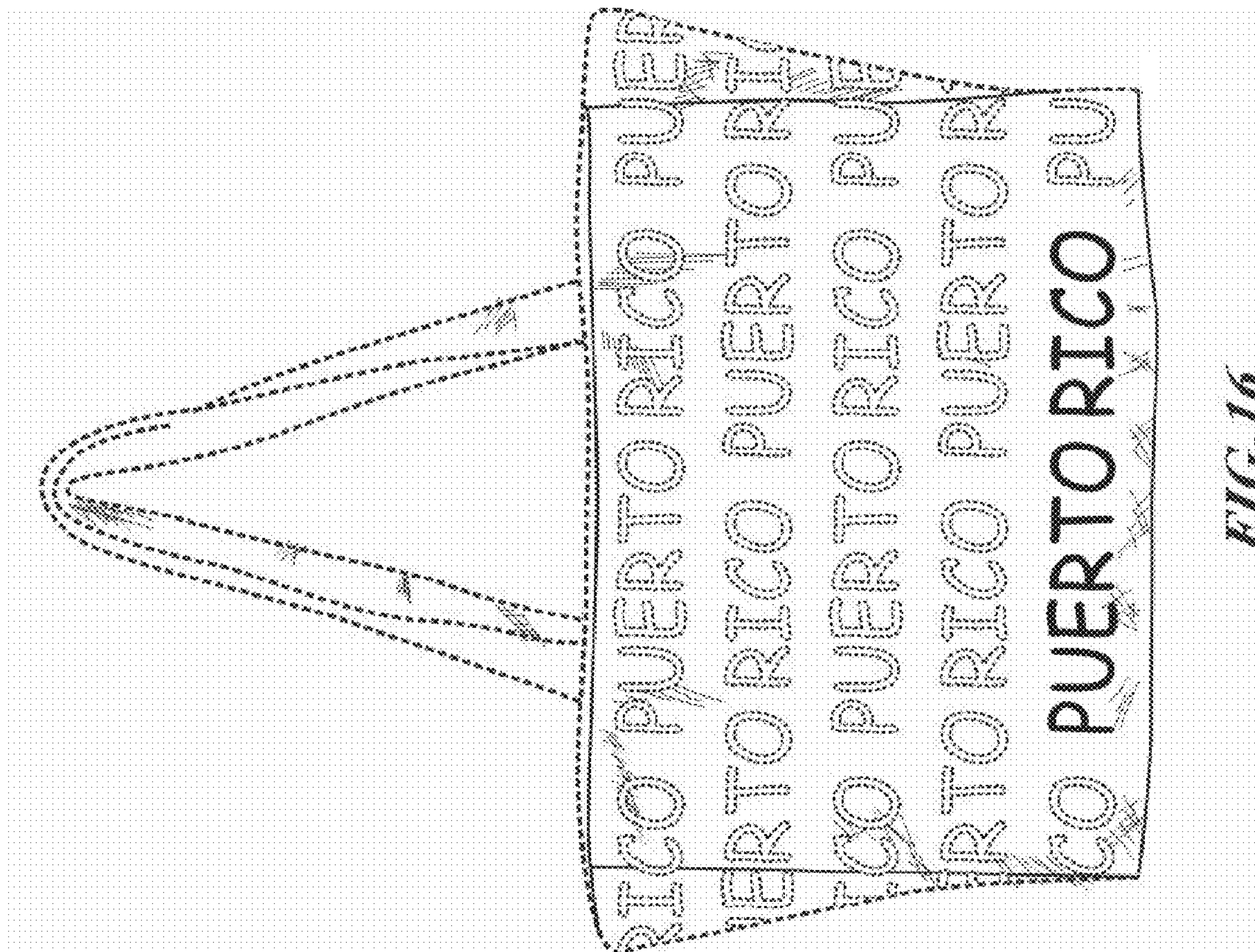

FIG. 15





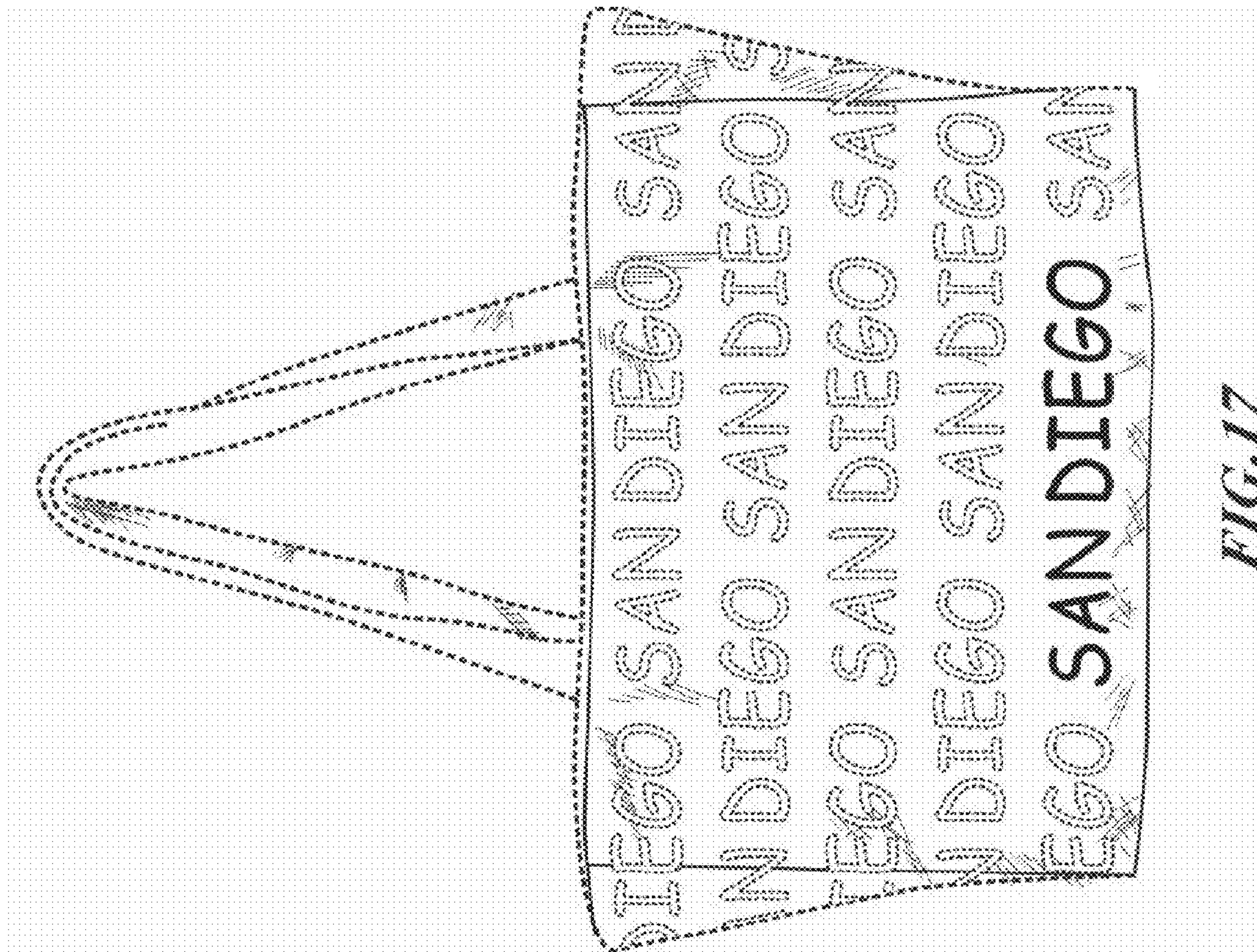

FIG.17

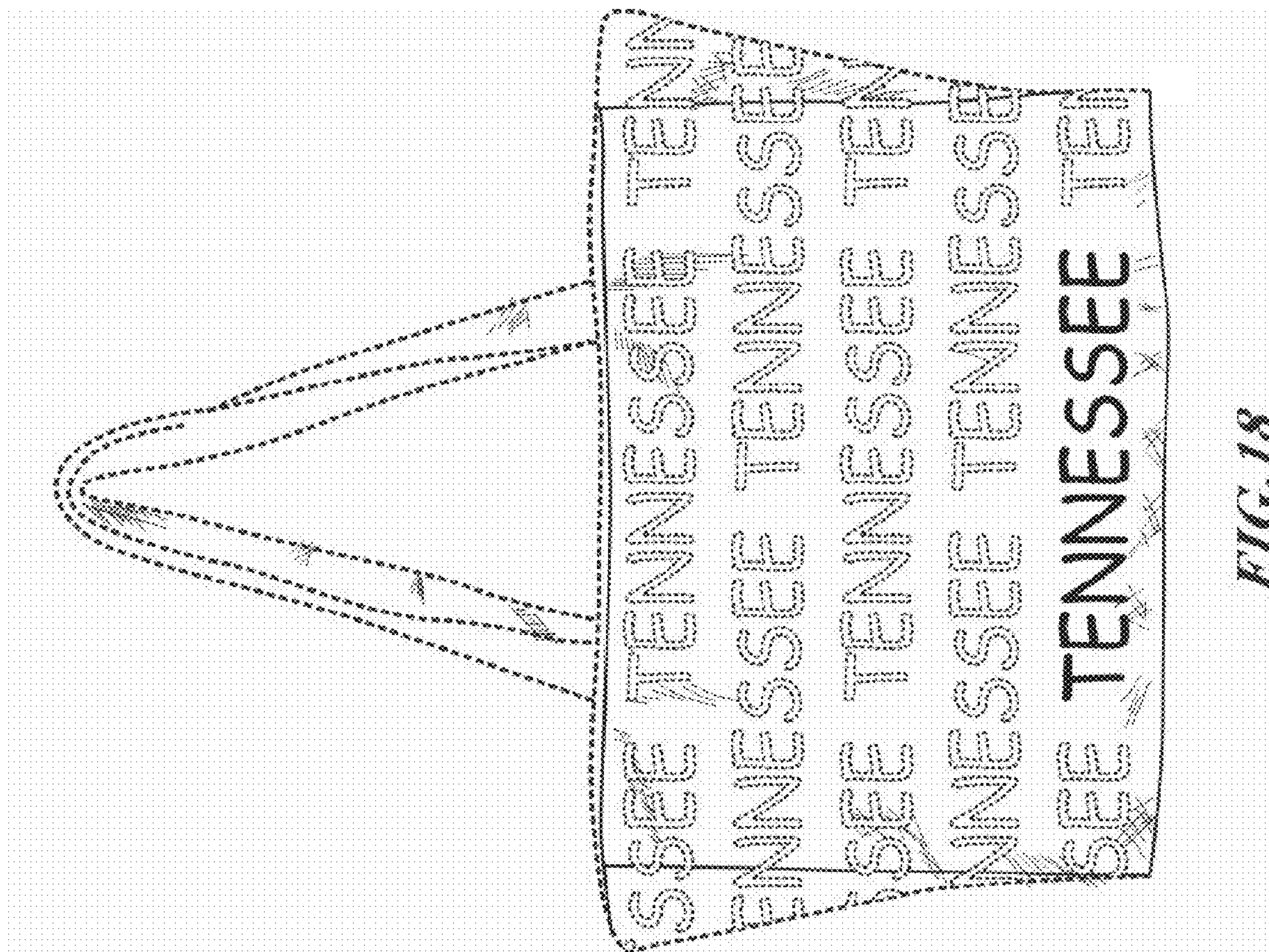

FIG. 18



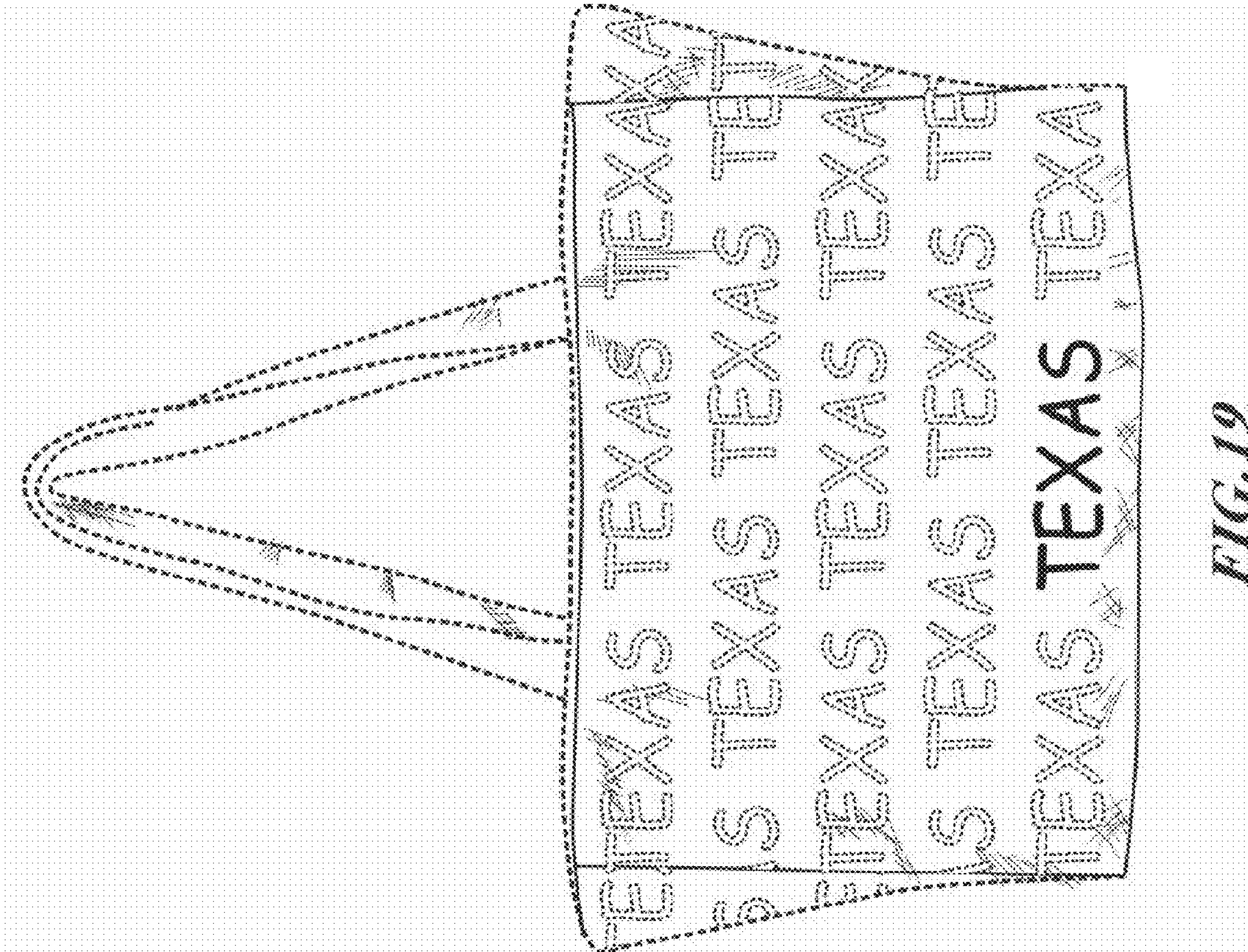

FIG. 19

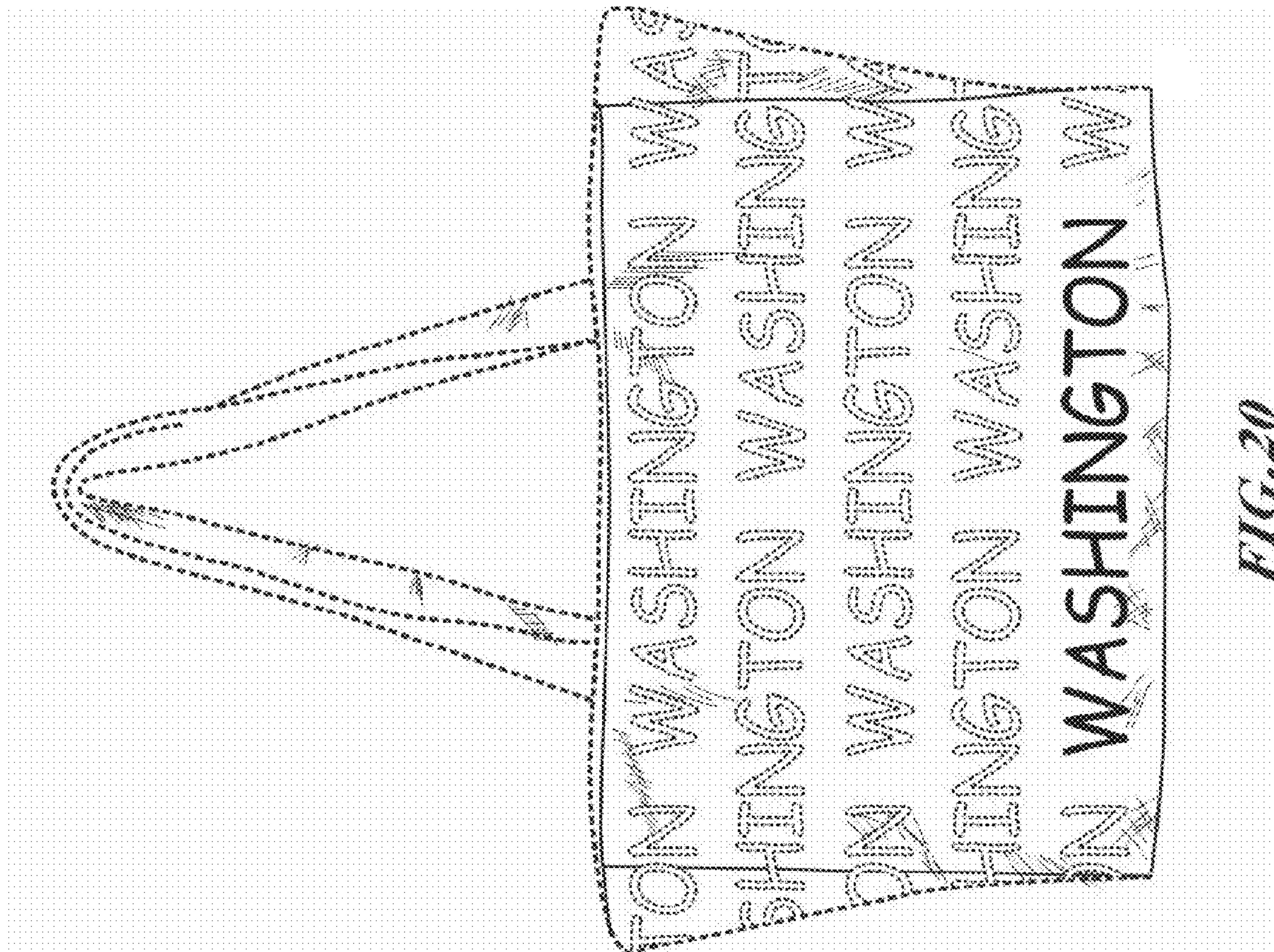

FIG. 20



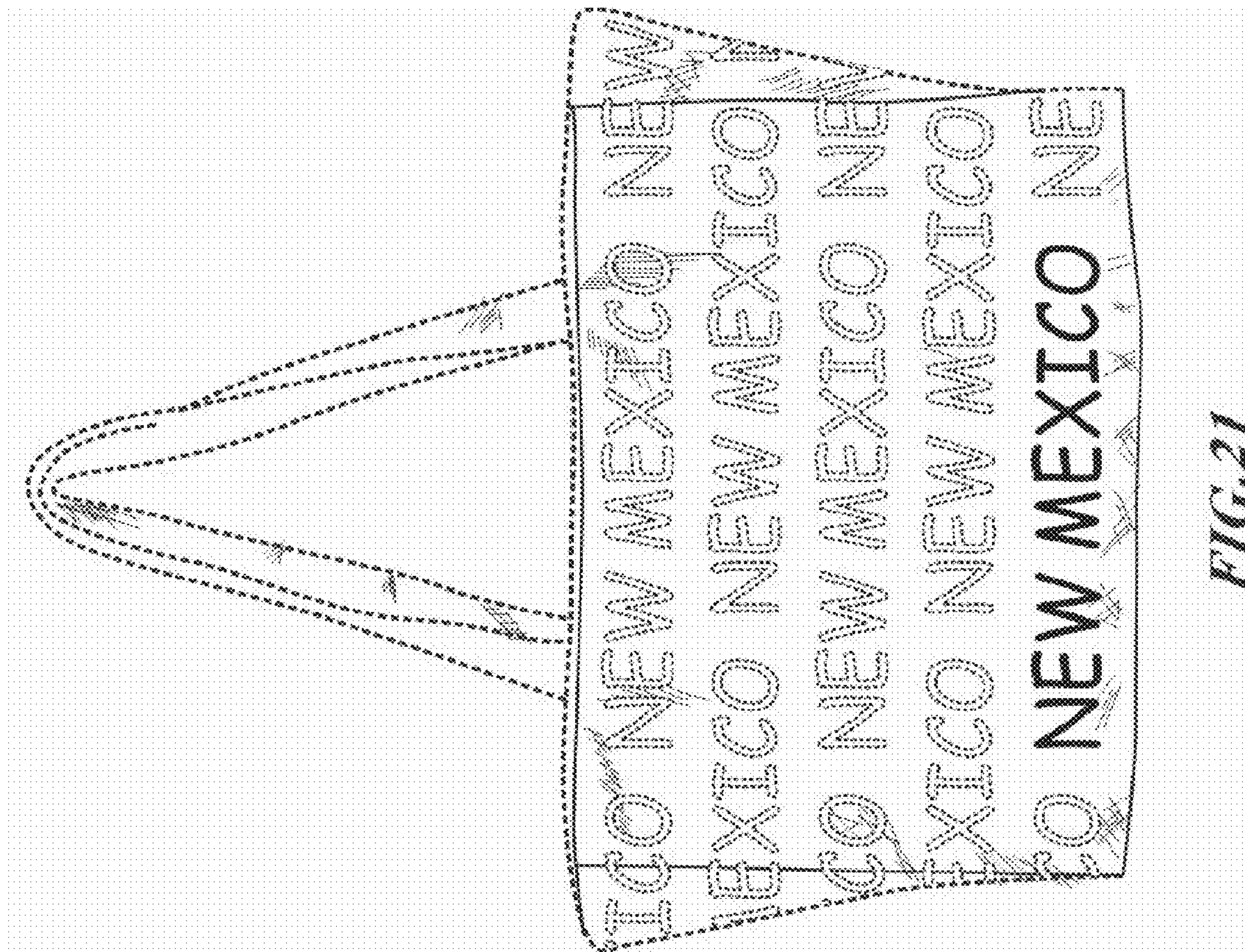

FIG. 21

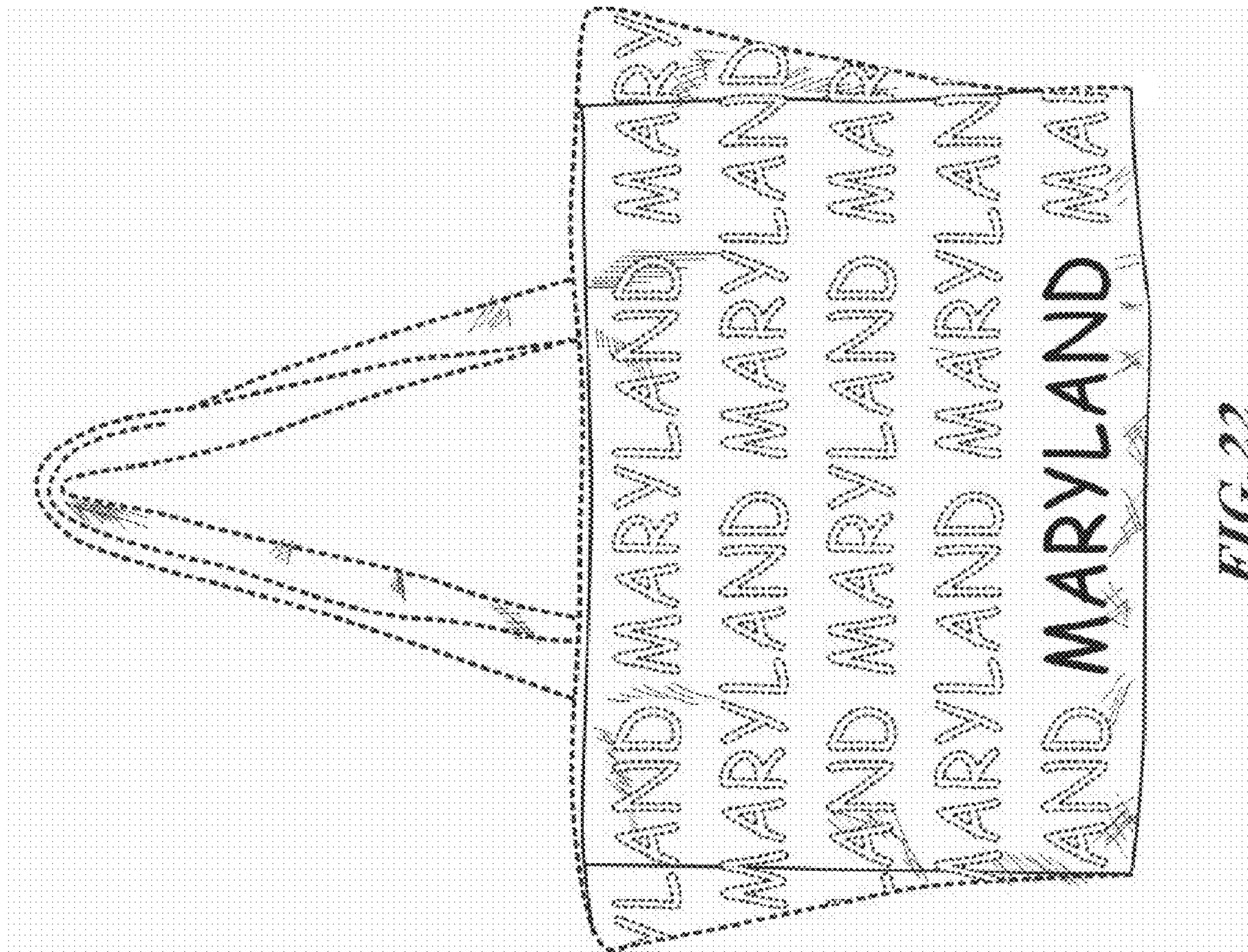

FIG. 22



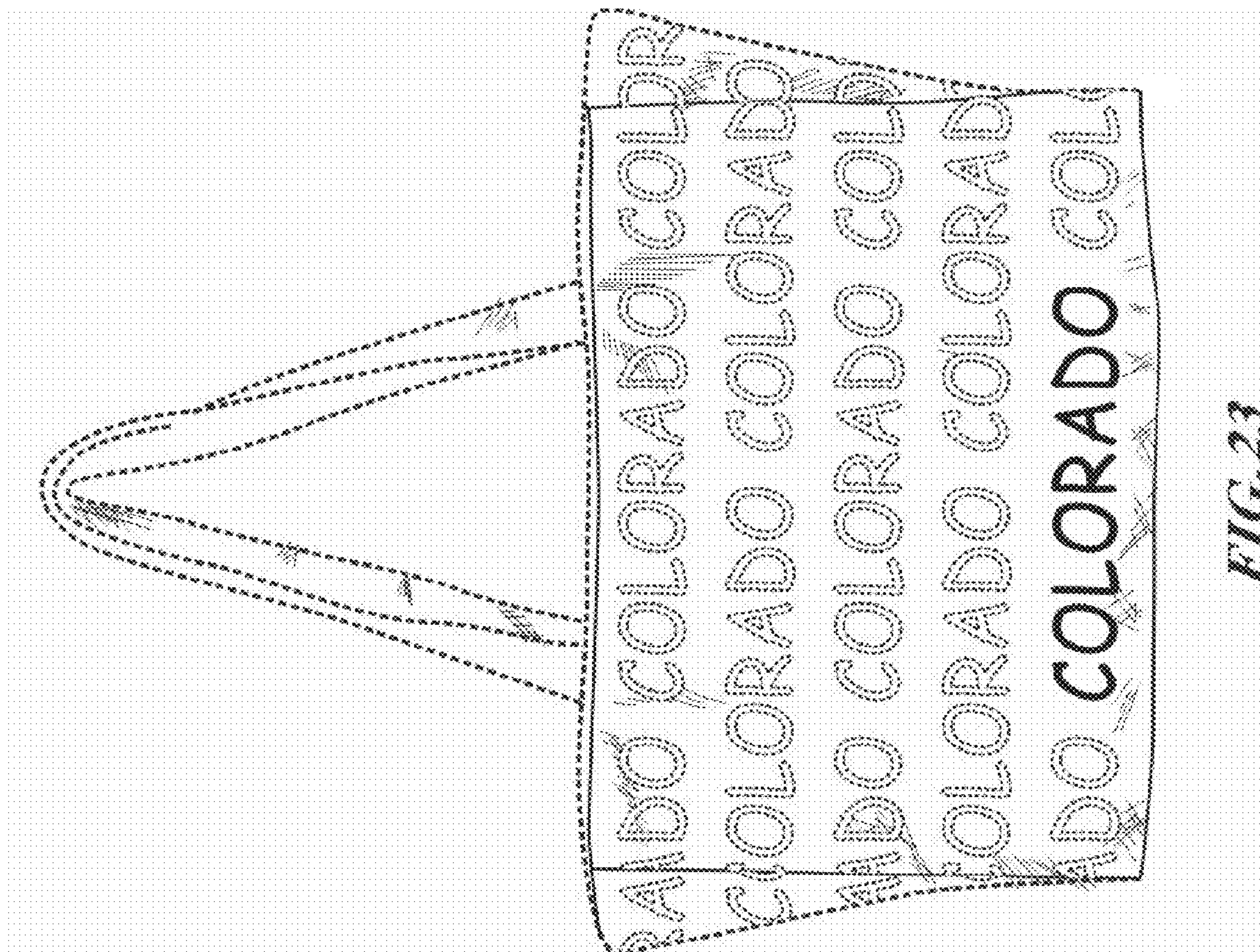

FIG. 23





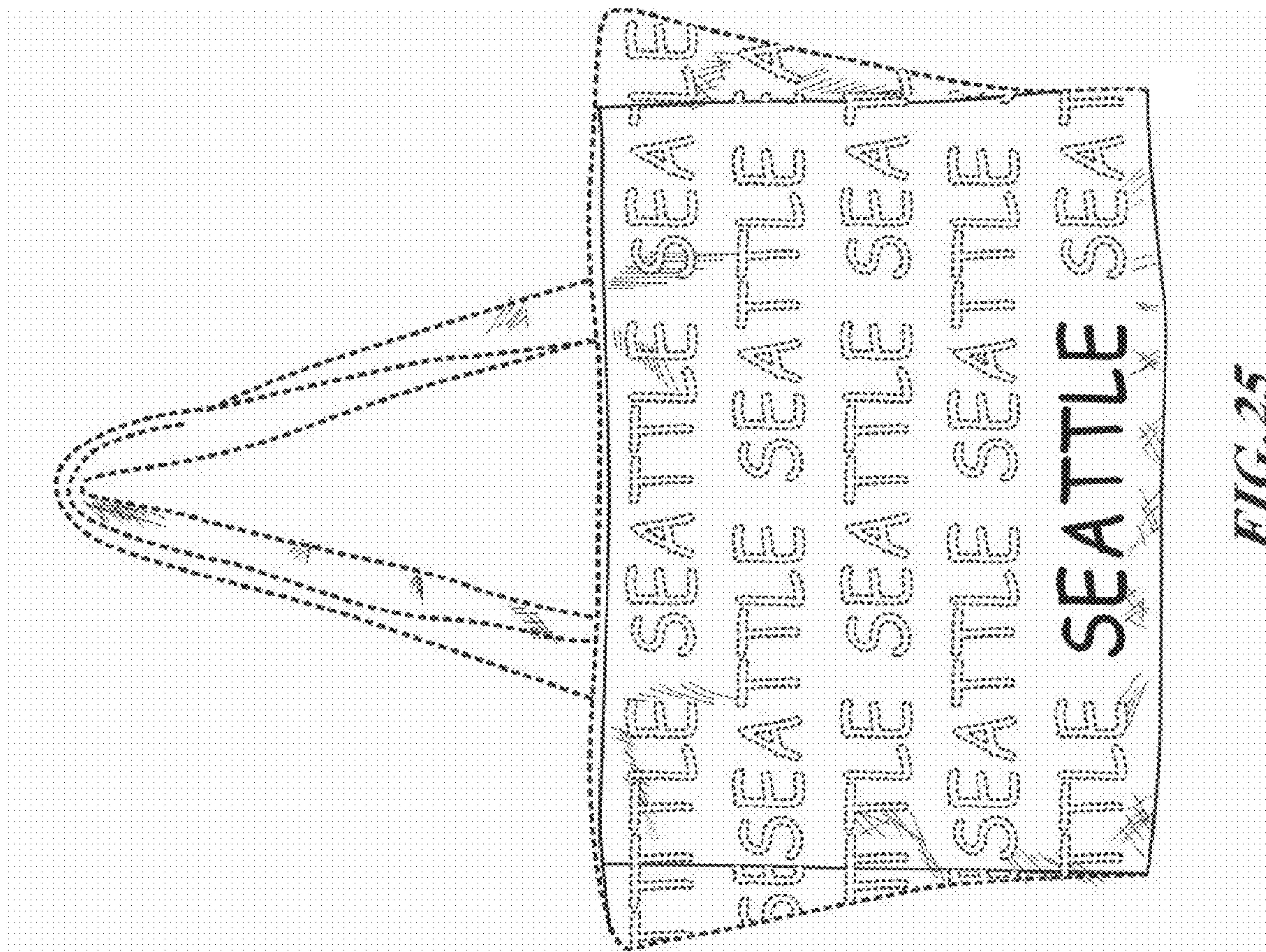

FIG. 25

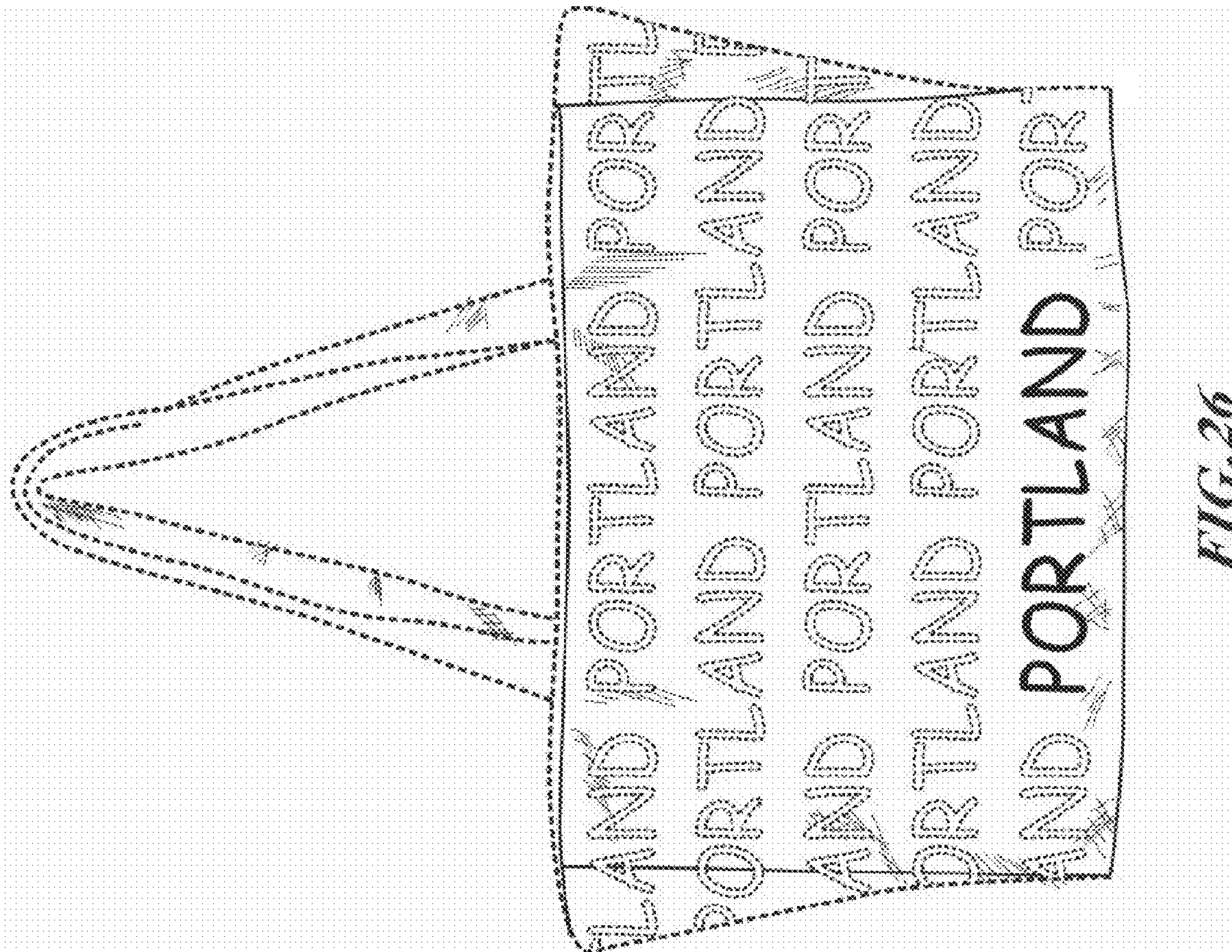

FIG. 26



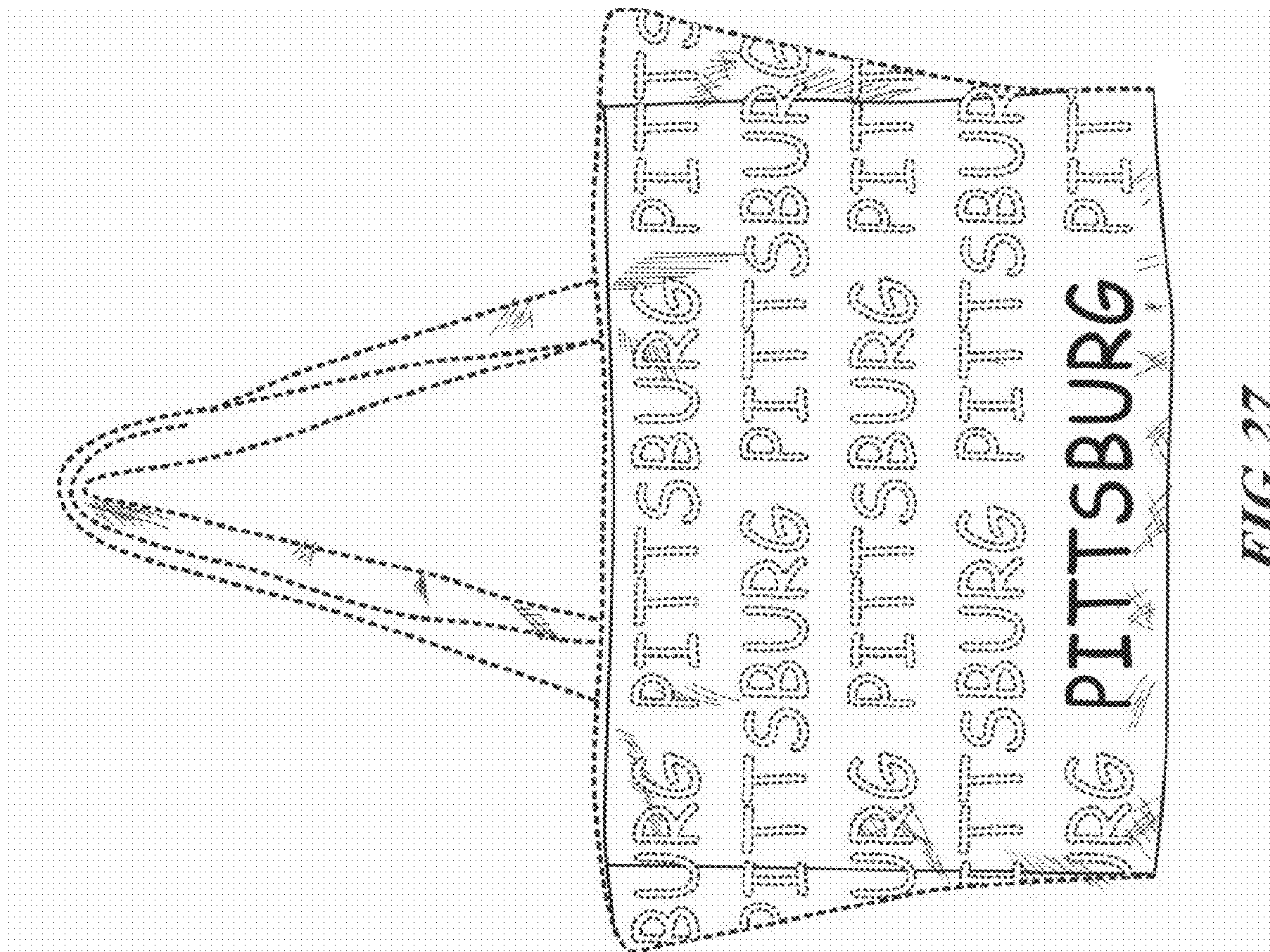

FIG. 27

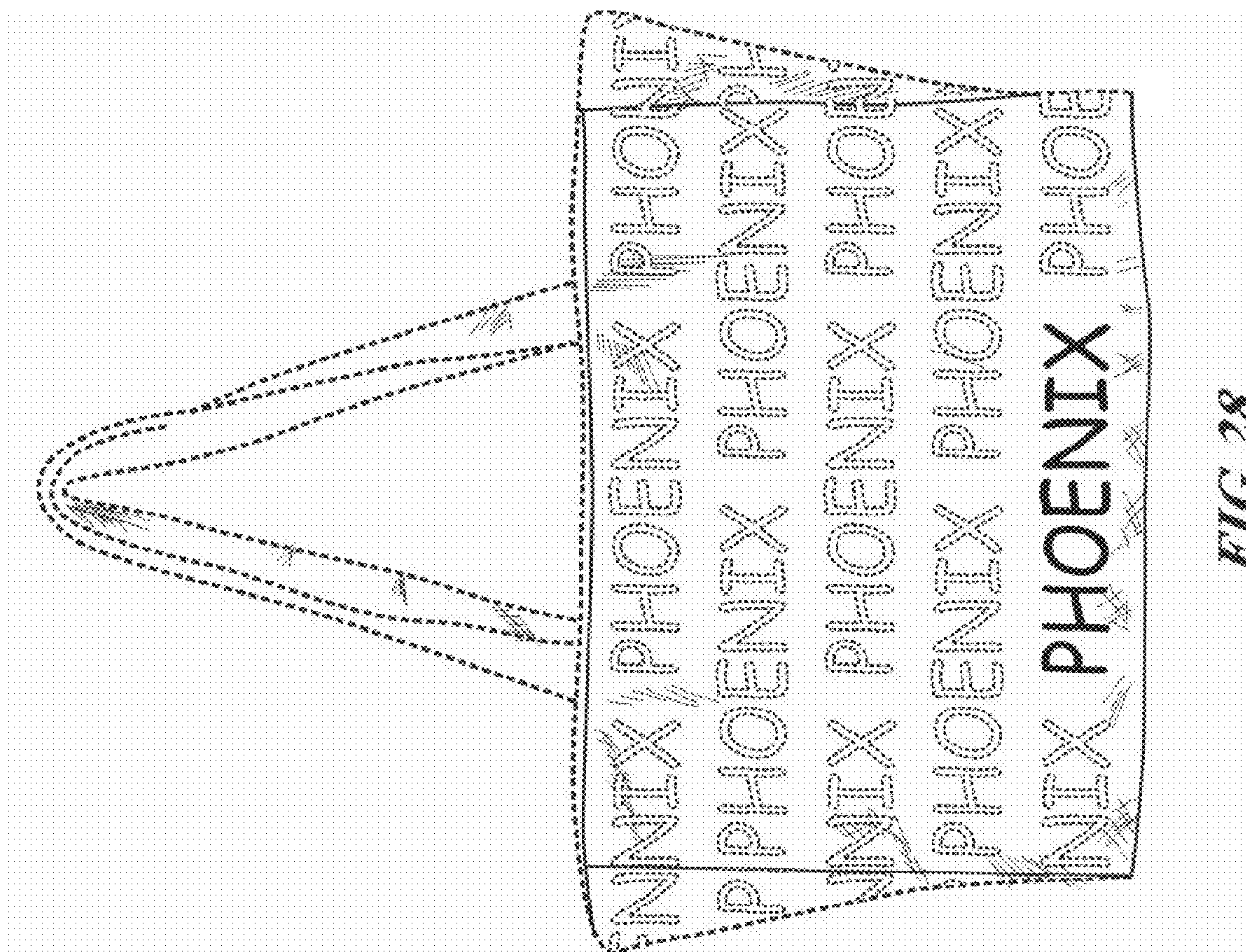

FIG. 28



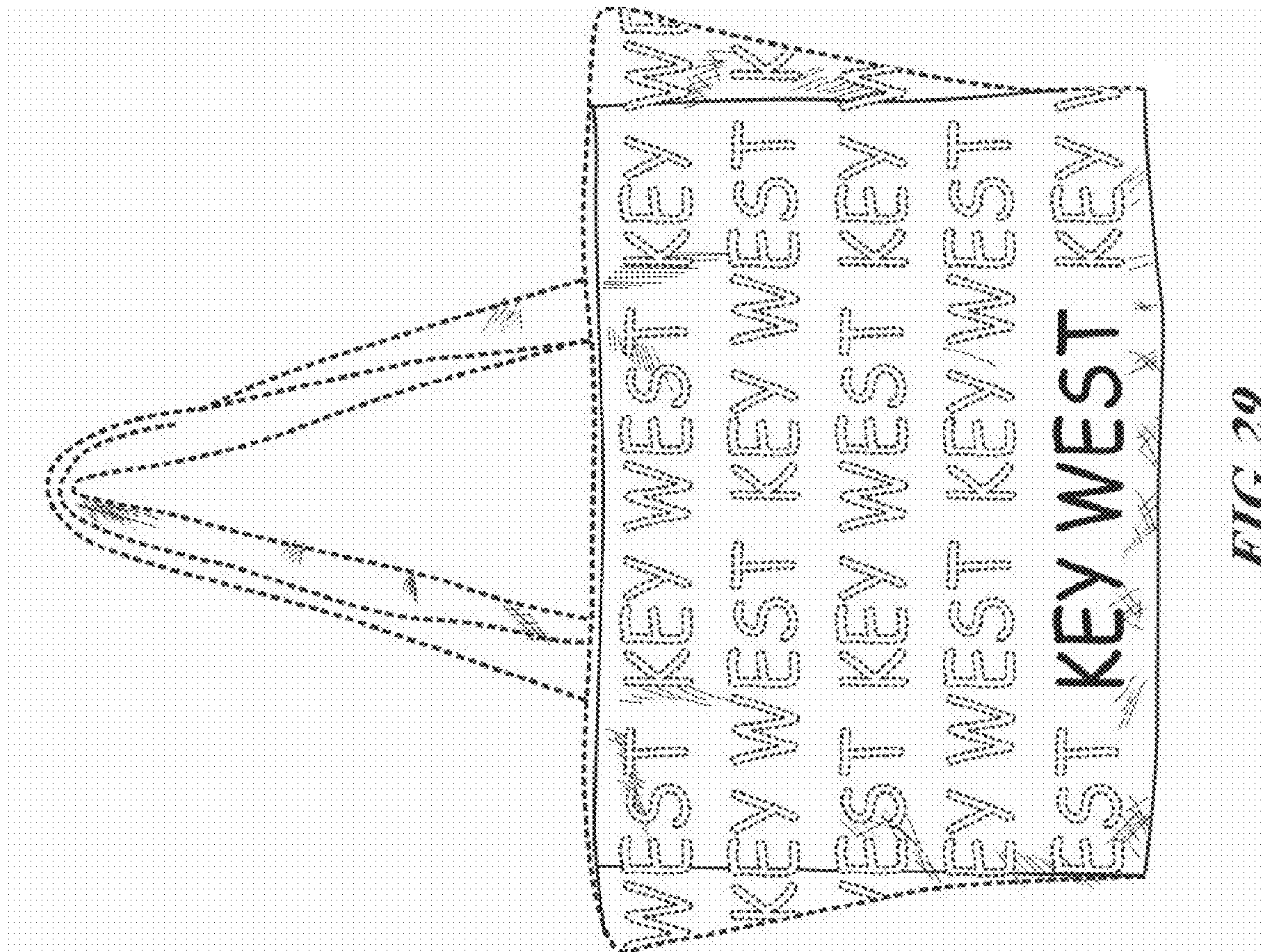

FIG. 29

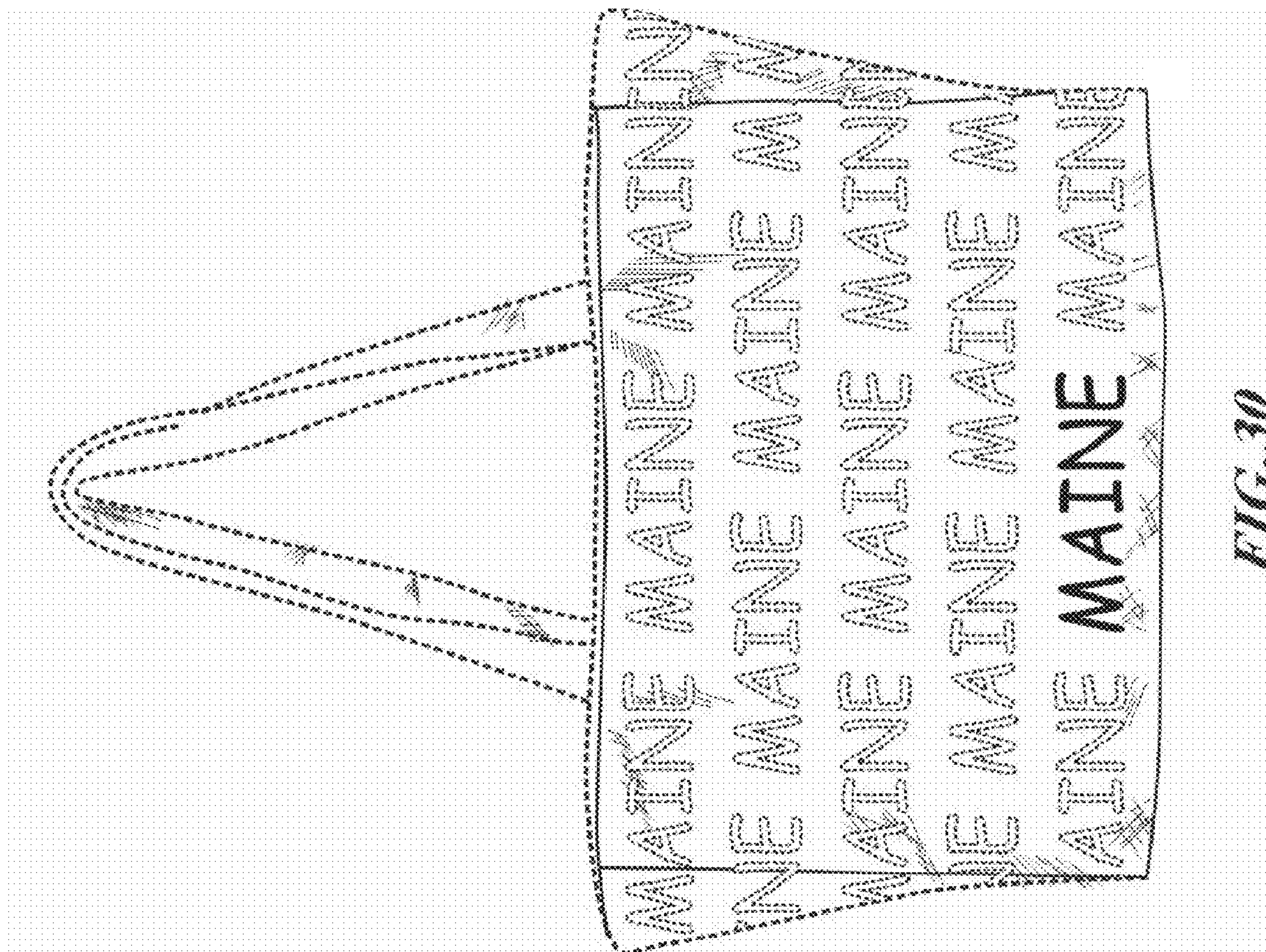

FIG. 30



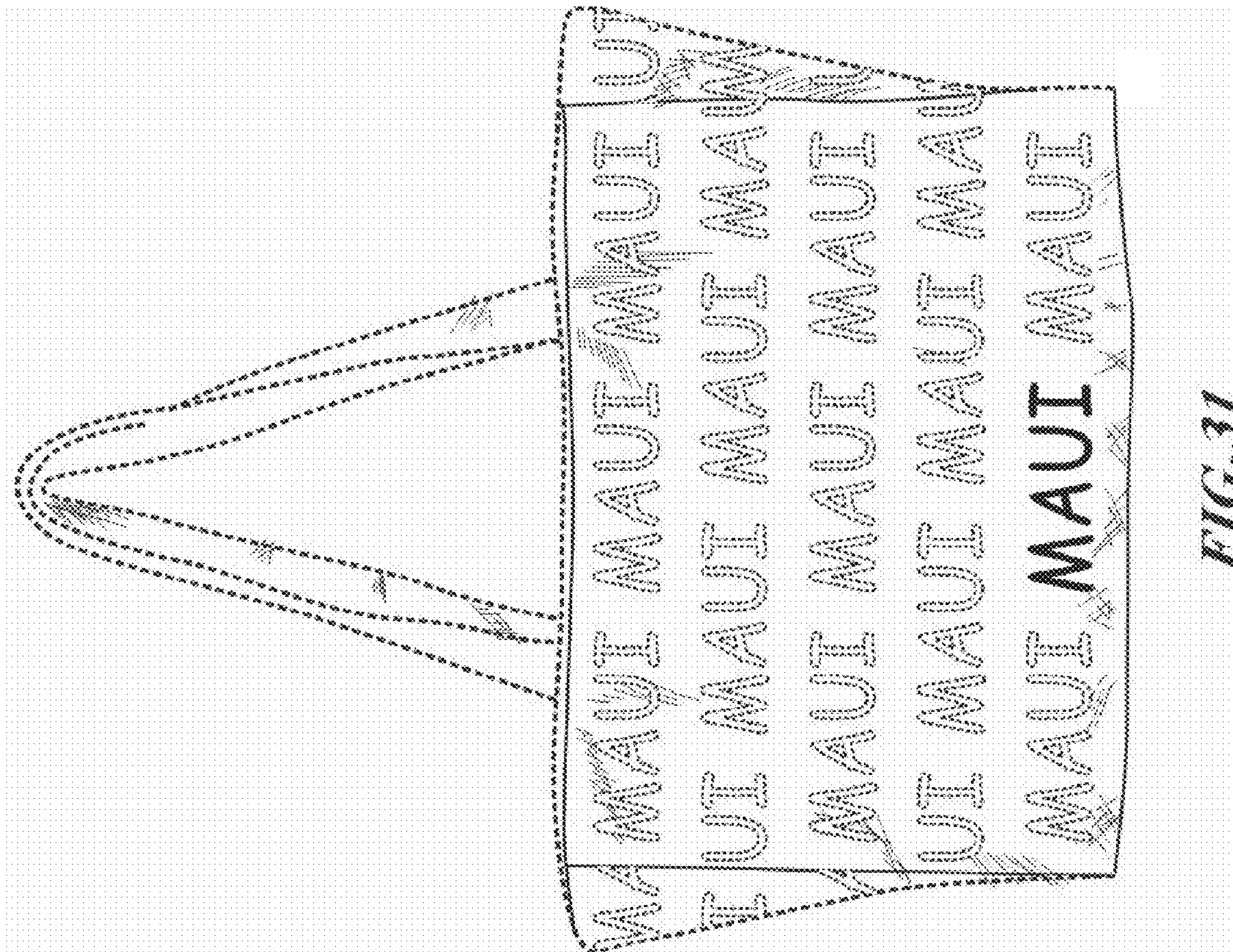

FIG. 31