



US00D612319S

(12) **United States Design Patent**  
**Bock**

(10) **Patent No.:** **US D612,319 S**  
(45) **Date of Patent:** **\*\* Mar. 23, 2010**

(54) **SET OF PARTITIONS FOR A COMMERCIAL AIRCRAFT PASSENGER CABIN**

(75) Inventor: **Thomas-Mathias Bock**, Grenade sur Garonne (FR)

(73) Assignee: **Airbus SAS**, Blagnac Cedex (FR)

(\*\*) Term: **14 Years**

(21) Appl. No.: **29/250,834**

(22) Filed: **Dec. 1, 2006**

(51) **LOC (9) Cl.** ..... **12-07**

(52) **U.S. Cl.** ..... **D12/345**

(58) **Field of Classification Search** ..... D12/345,  
D12/106, 20, 42, 43, 317, 319, 356; D6/349,  
D6/350, 355, 492, 332, 356, 511; 297/118;  
244/118.1, 118.2, 118.5, 118.6, 119, 120,  
244/121

See application file for complete search history.

(56) **References Cited**

**U.S. PATENT DOCUMENTS**

3,801,152	A *	4/1974	Tims et al.	.....	296/78.1
D248,912	S *	8/1978	Canfield et al.	.....	D6/421
D349,608	S *	8/1994	Savoie	.....	D6/332
D412,625	S *	8/1999	Montague et al.	.....	D6/421
D421,948	S *	3/2000	Dryburgh et al.	.....	D12/195
D458,041	S *	6/2002	Couture et al.	.....	D6/332
2002/0017810	A1 *	2/2002	Dryburgh et al.	.....	297/354.13
2006/0170261	A1 *	8/2006	Baatz et al.	.....	297/245

**OTHER PUBLICATIONS**

- U.S. Appl. No. 29/250,809. Title: Partition for a Commercial Aircraft Passenger Cabin, filed Dec. 1, 2006.
- U.S. Appl. No. 29/250,814. Title: Partition for a Commercial Aircraft Passenger Cabin, filed Dec. 1, 2006.
- U.S. Appl. No. 29/250,818. Title: Partition for a Commercial Aircraft Passenger Cabin, filed Dec. 1, 2006.
- U.S. Appl. No. 29/250,828. Title: Partition for a Commercial Aircraft Passenger Cabin, filed Dec. 1, 2006.

(Continued)

*Primary Examiner*—Cathron C Brooks

*Assistant Examiner*—Kevin K Rudzinski

(74) *Attorney, Agent, or Firm*—Osler, Hoskin & Harcourt LLP

(57) **CLAIM**

The ornamental design for a set of partitions for a commercial aircraft passenger cabin, as shown and described.

**DESCRIPTION**

FIG. 1 is a top plan view of a set of partitions for a commercial aircraft passenger cabin according to my design;

FIG. 2 is a front elevation view thereof;

FIG. 3 is a left side elevation view thereof;

FIG. 4 is a right side elevation view thereof;

FIG. 5 is a top plan view of the set of partitions of FIG. 1, shown with commercial aircraft passenger cabin seats, ottomans, and additional partitions;

FIG. 6 is a front, left perspective view of the set of partitions of FIG. 1, shown in a commercial aircraft passenger cabin; and,

FIG. 7 is a top plan view of the set of partitions and cabin as shown in FIG. 6.

No bottom plan and rear elevation views are included as no features of the claimed design are visible therein.

Throughout the Figures, the broken lines on the partitions represent the unclaimed boundaries of the claimed design, with the shaded areas being part of the claimed design and the non-shaded areas forming no part of the claimed design. The broken lines showing environment are for illustrative purposes only and form no part of the claimed design.

As shown in the Figures, both the design of the individual partitions and the partition arrangement (the positioning of each with respect to the others) are within the scope of the claimed design.

**1 Claim, 6 Drawing Sheets**

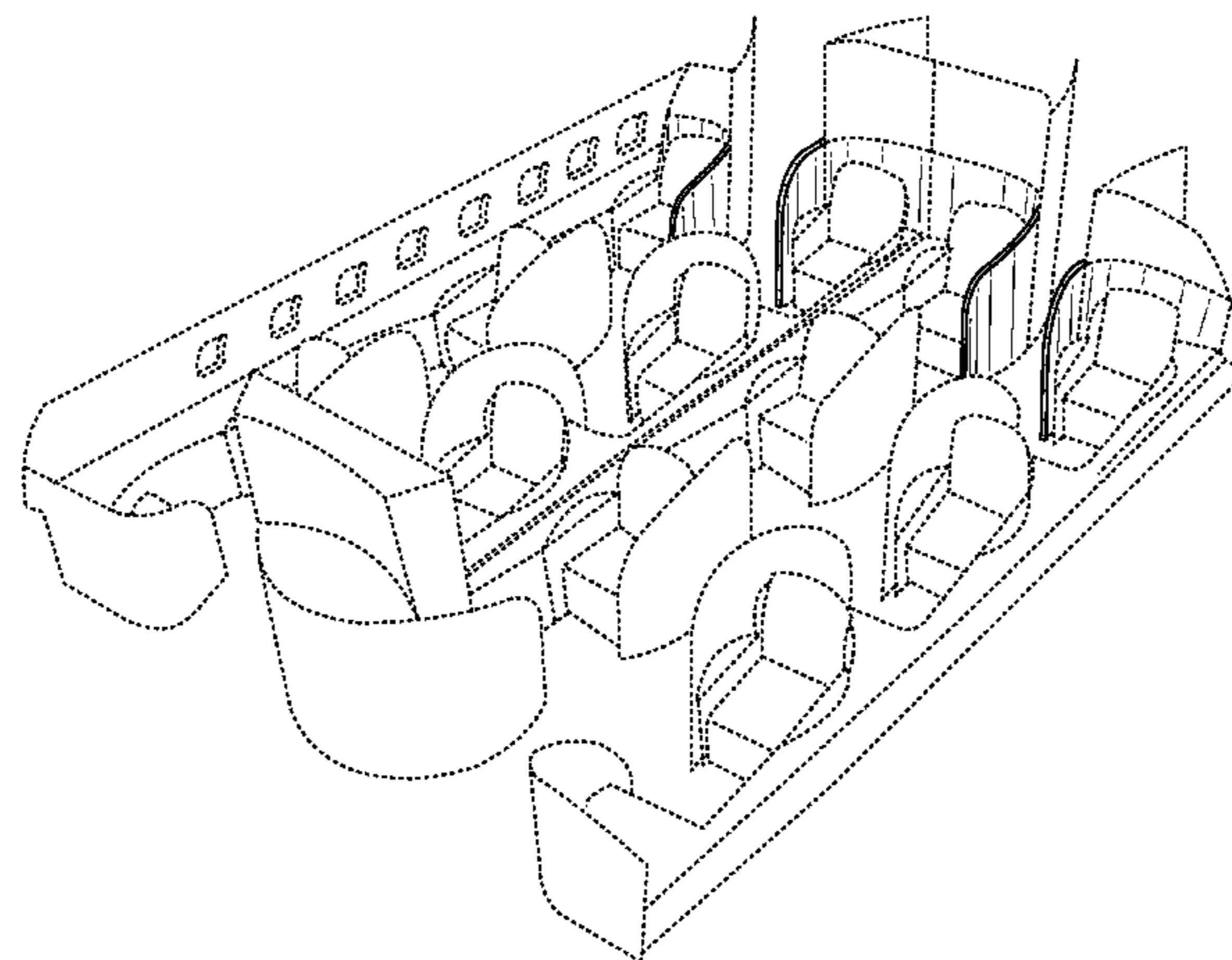

OTHER PUBLICATIONS

U.S. Appl. No. 29/250,831. Title: Seat Body for a Commercial Aircraft Passenger Cabin, filed Dec. 1, 2006.

U.S. Appl. No. 29/250,826. Title: Seat Layout for a Commercial Aircraft Passenger Cabin, filed Dec. 1, 2006.

U.S. Appl. No. 29/250,825. Title: Partition Layout for a Commercial Aircraft Passenger Cabin, filed Dec. 1, 2006.

U.S. Appl. No. 29/250,833. Title: Partition Layout for a Commercial Aircraft Passenger Cabin, filed Dec. 1, 2006.

U.S. Appl. No. 29/250,832. Title: Ottoman for a Commercial Aircraft Passenger Cabin, filed Dec. 1, 2006.

U.S. Appl. No. 29/250,811. Title: Seat for a Commercial Aircraft Passenger Cabin, filed Dec. 1, 2006.

U.S. Appl. No. 29/250,810. Title: Furniture for a Commercial Aircraft Passenger Cabin, filed Dec. 1, 2006.

U.S. Appl. No. 29/250,829. Title: Furniture for a Commercial Aircraft Passenger Cabin, filed Dec. 1, 2006.

U.S. Appl. No. 29/250,813. Title: Armrest/Backrest Combination for an Ottoman for a Commercial Aircraft Passenger Cabin, filed Dec. 1, 2006.

\* cited by examiner

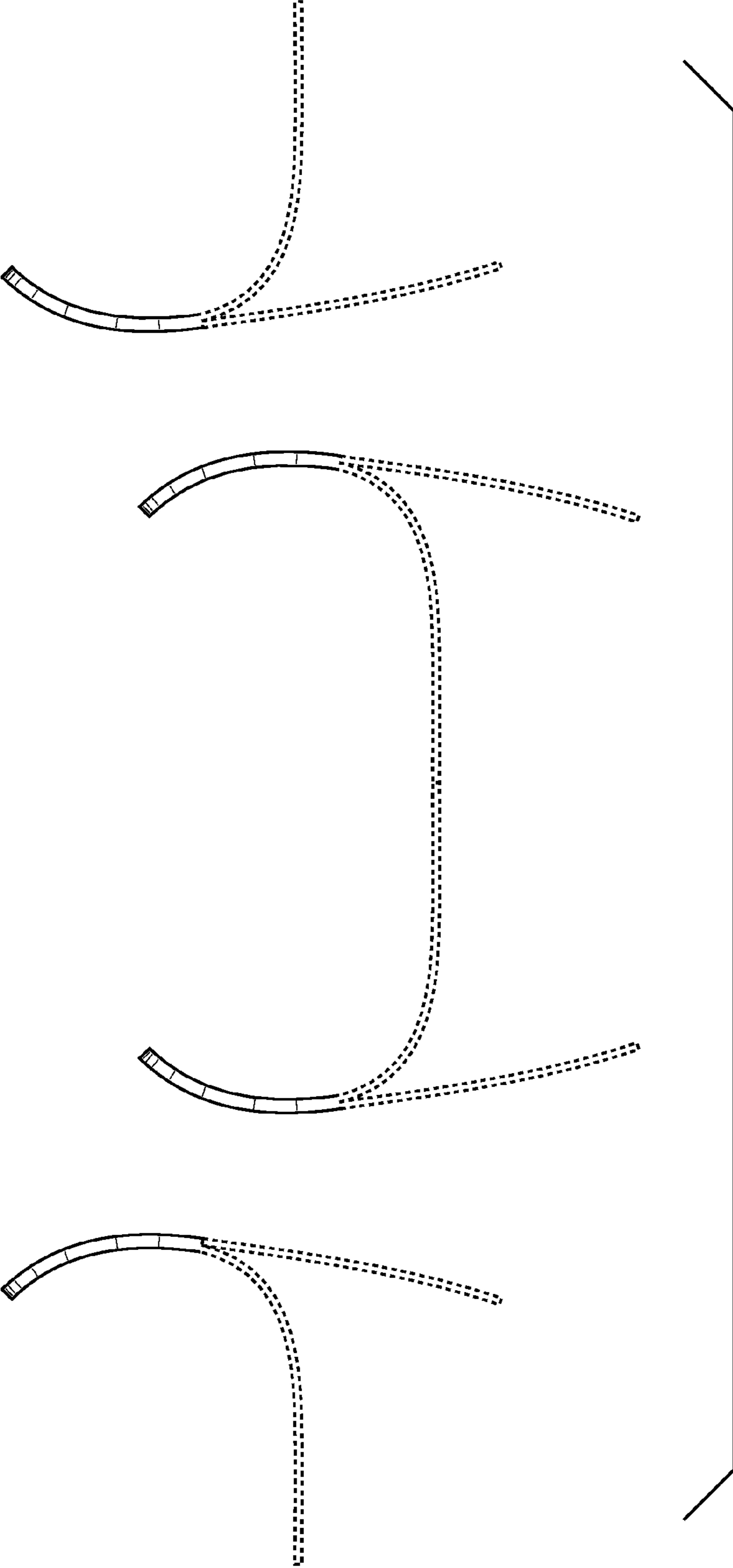

**FIG. 1**

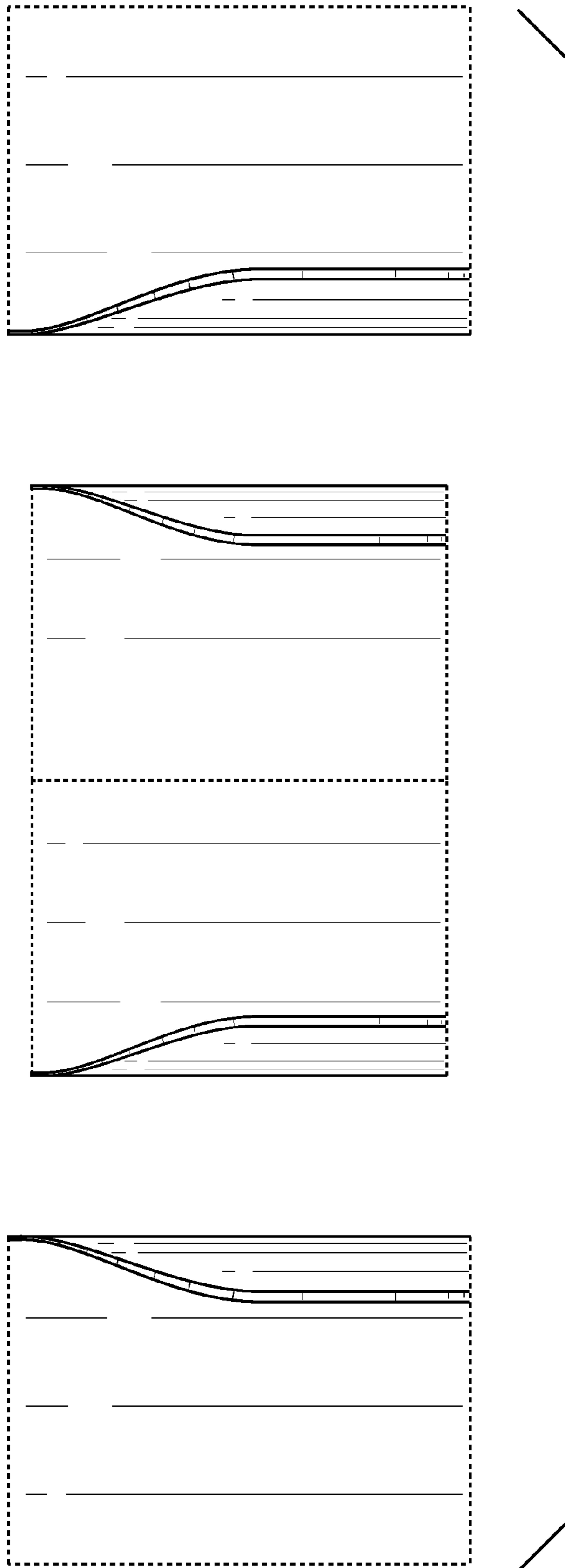

**FIG. 2**

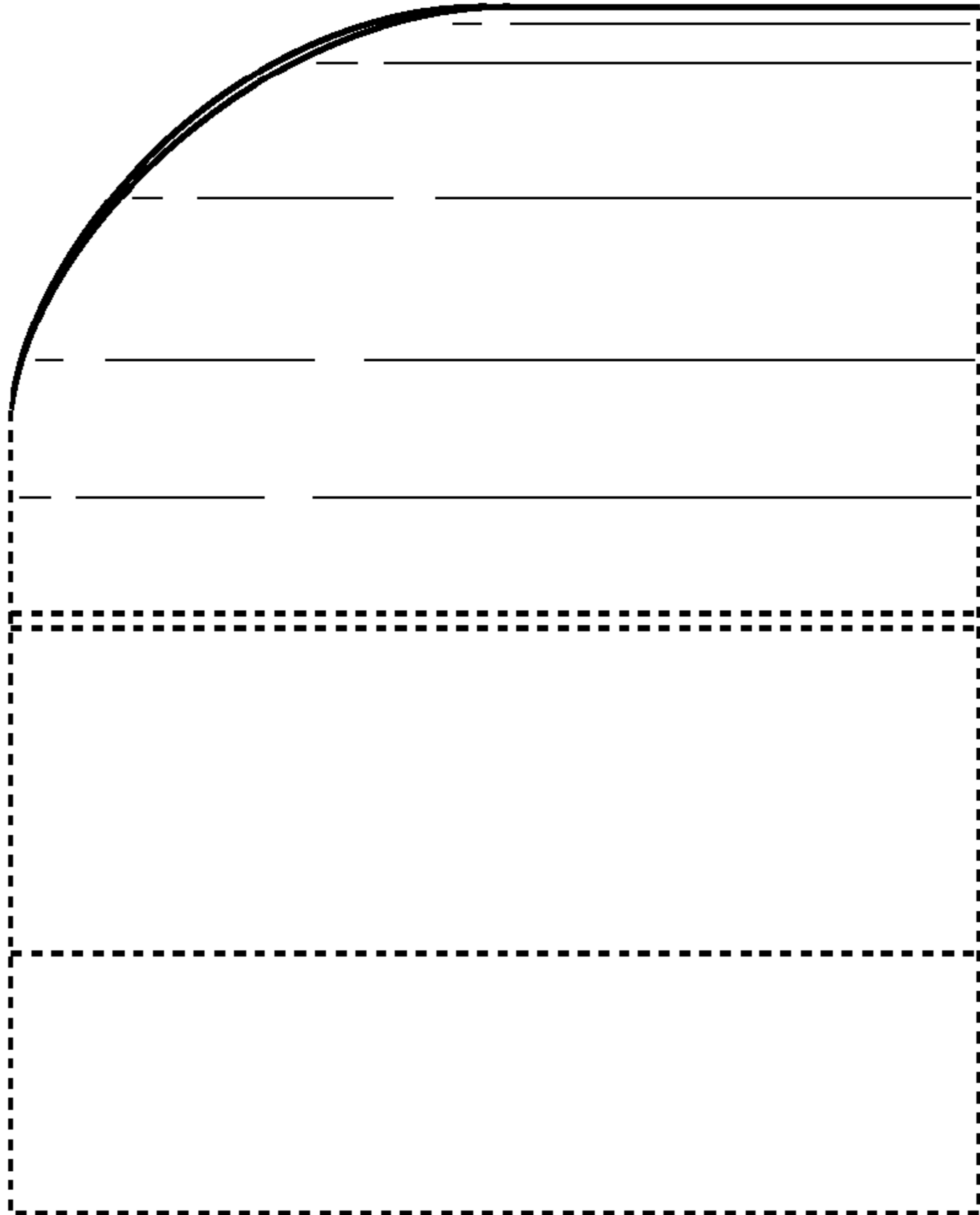

**FIG. 4**

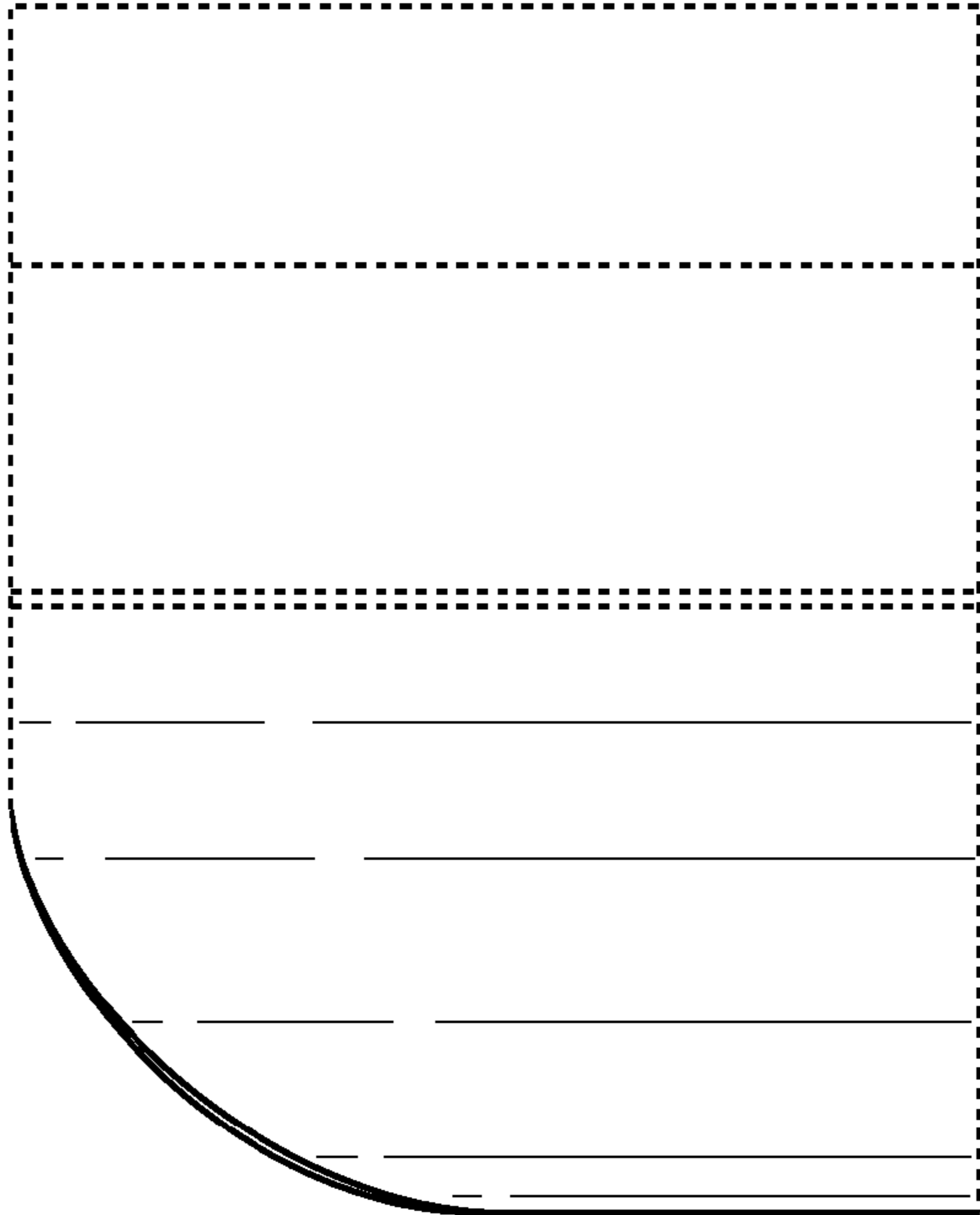

**FIG. 3**

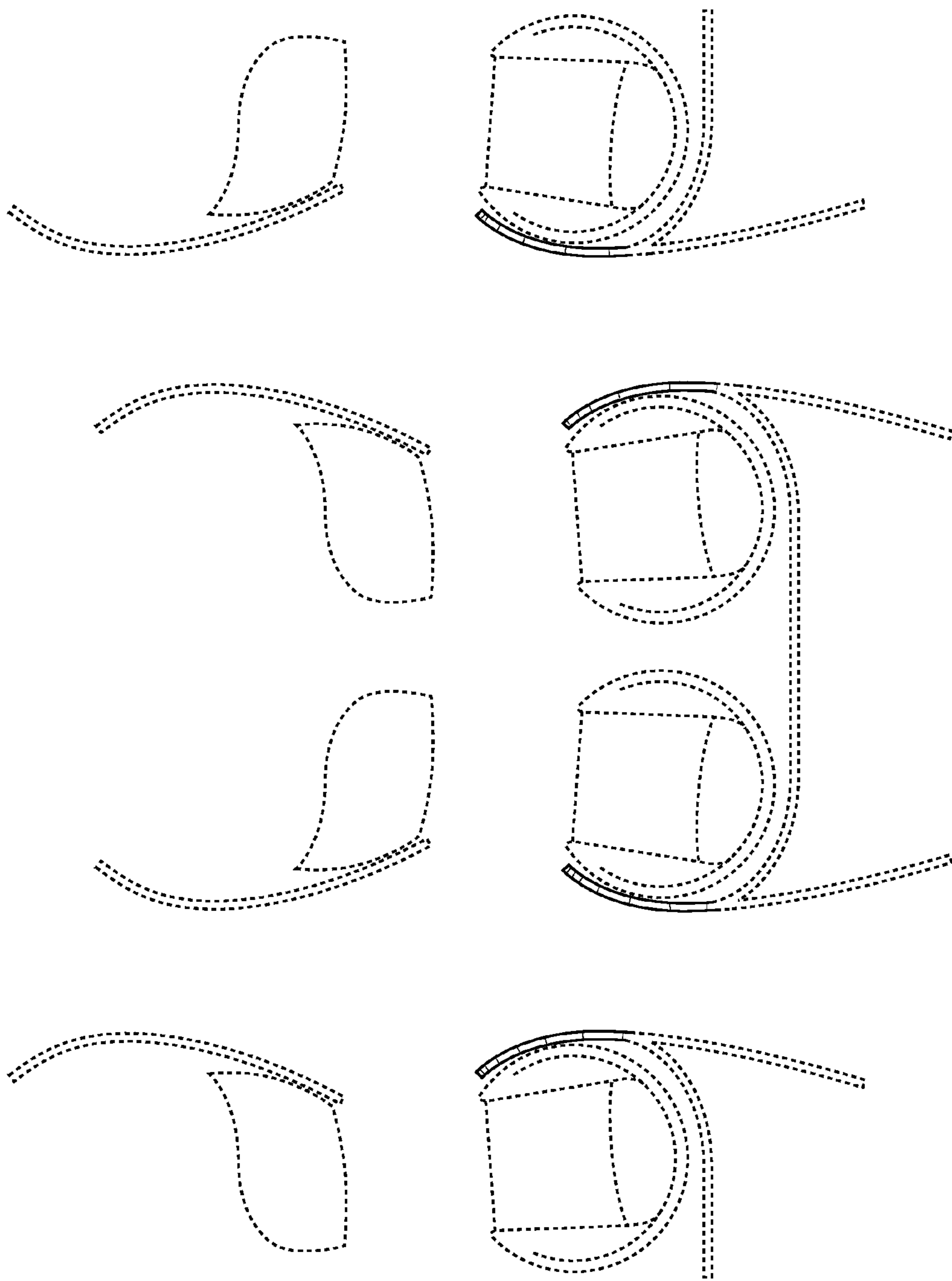

**FIG. 5**

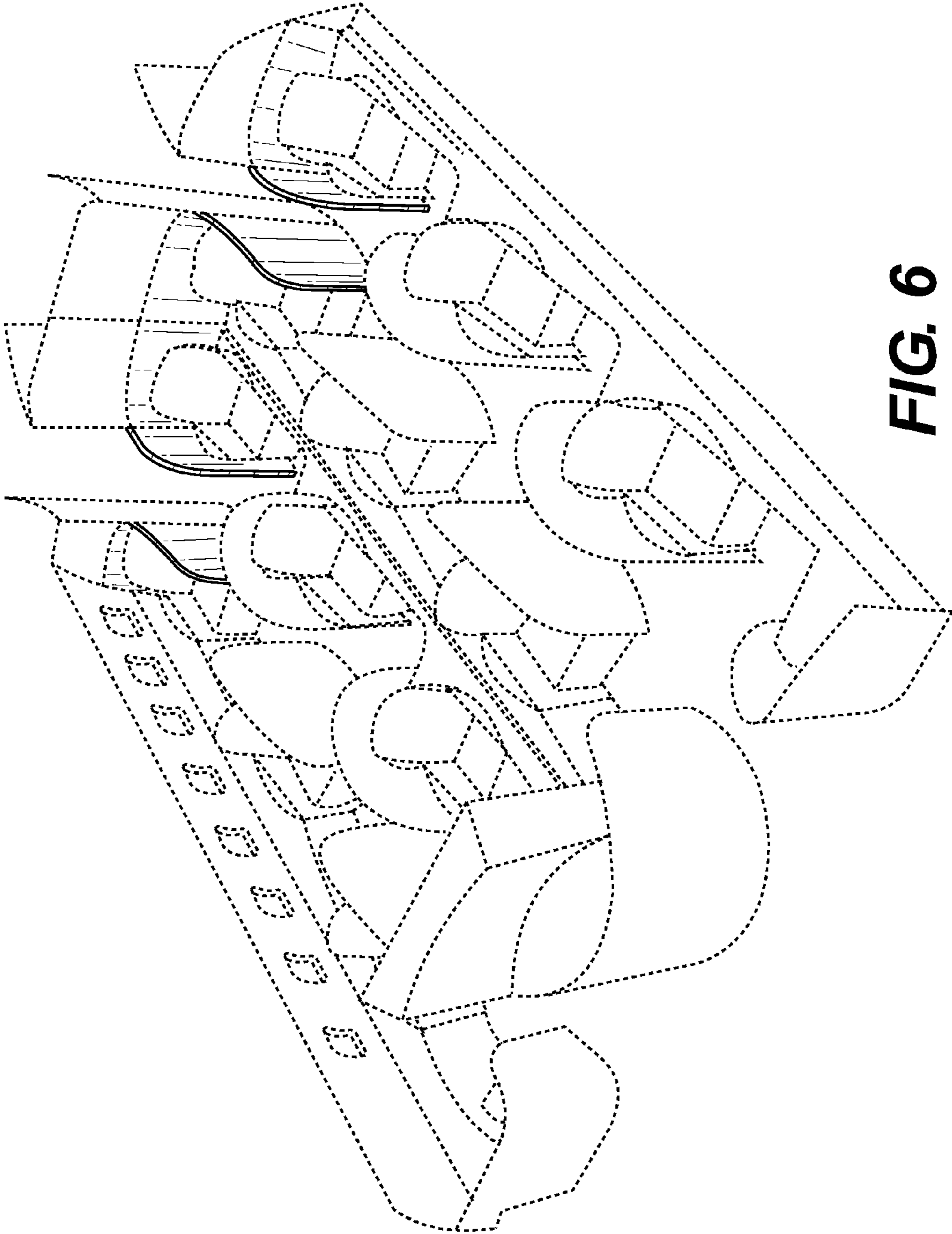

**FIG. 6**

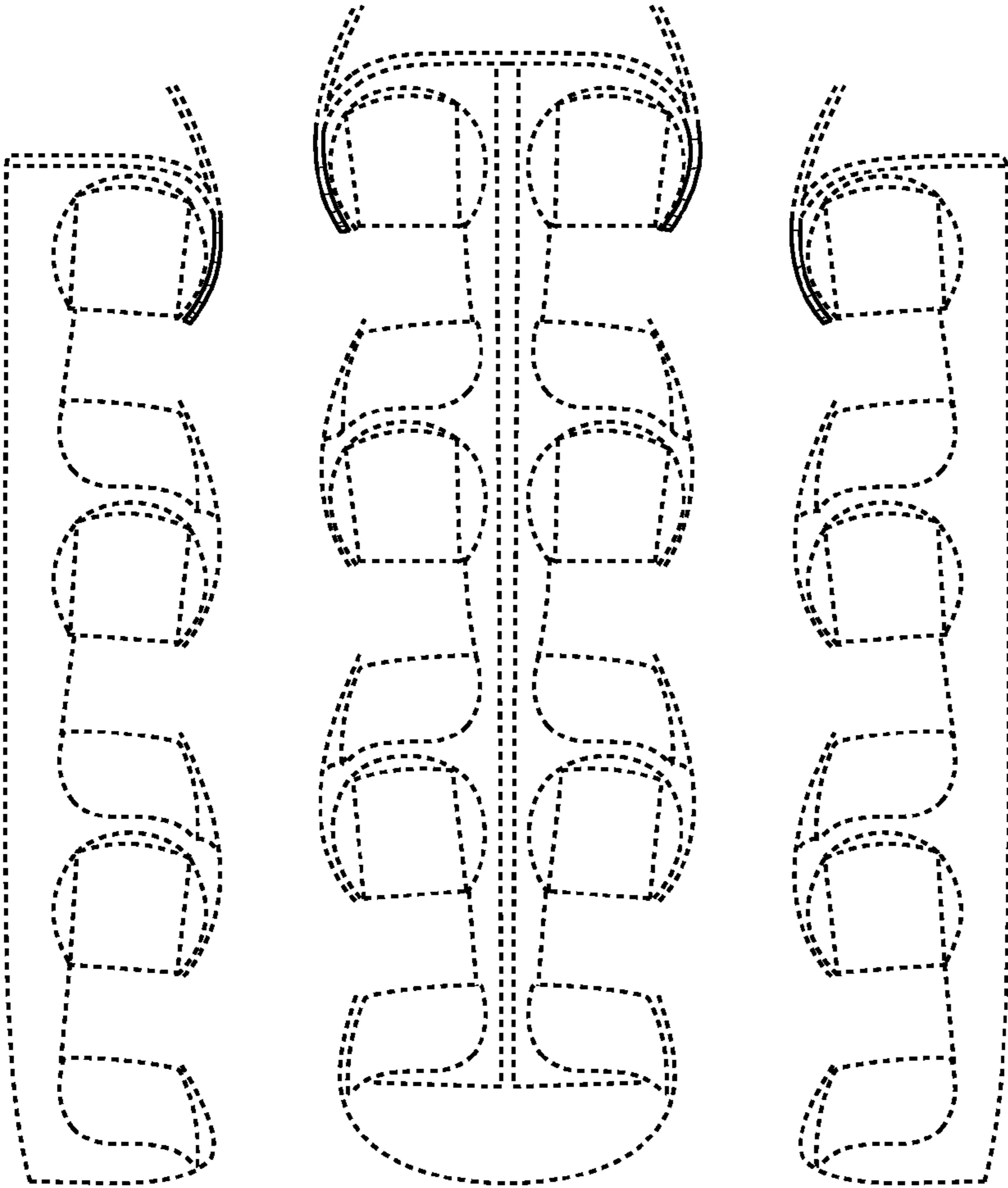

**FIG. 7**