



US00D612281S

(12) **United States Design Patent**  
**Andretti**

(10) **Patent No.:** **US D612,281 S**  
(45) **Date of Patent:** **\*\* Mar. 23, 2010**

(54) **RACECAR ROSARY**

D507,689 S 7/2005 Schmitt  
D517,443 S 3/2006 Dennis

(76) Inventor: **Sandra Cecelia Andretti**, 1201 Seifert Rd., Nazareth, PA (US) 18064

**OTHER PUBLICATIONS**

(\*\*) Term: **14 Years**

[http://www.kaboodle.com/hi/img/c/0/0/46/0/AAAADFNE3g0AAAAAEYK\\_A.jpg](http://www.kaboodle.com/hi/img/c/0/0/46/0/AAAADFNE3g0AAAAAEYK_A.jpg). Accessed Dec. 30, 2009.\*  
<http://www.handmaid-jewelry.com/rosaries/midnight-black-rosary.jpg>. Accessed Dec. 30, 2009.\*

(21) Appl. No.: **29/335,490**

\* cited by examiner

(22) Filed: **Apr. 16, 2009**

(51) **LOC (9) Cl.** ..... **11-01**

*Primary Examiner*—Cathron C Brooks

(52) **U.S. Cl.** ..... **D11/3; D99/26**

*Assistant Examiner*—Melanie Levy

(58) **Field of Classification Search** ..... D11/1–26,  
D11/29, 37–39, 61, 81, 101, 69; D99/25–27;  
63/3, 3.1, 3.2, 15

(74) *Attorney, Agent, or Firm*—QuickPatents, Inc.; Kevin Prince

See application file for complete search history.

(57) **CLAIM**

(56) **References Cited**

I claim the ornamental design for a racecar rosary, as shown and described.

**U.S. PATENT DOCUMENTS**

**DESCRIPTION**

D37,659 S *	11/1905	Nehr	.....	D99/26
D37,876 S	3/1906	Teubner		
D63,129 S	10/1923	Evans		
D137,865 S	5/1944	Kelley		
D146,577 S	4/1947	Kelley		
D155,819 S	11/1949	Lukeman		
D160,693 S	10/1950	Civelli		
D179,845 S	3/1957	Goodman		
D201,254 S	6/1965	Sloan		
D211,539 S	6/1968	Lademann		
D225,444 S	12/1972	McMahon		
D232,683 S	9/1974	Levine		
D307,501 S	4/1990	Abel		
D307,502 S	4/1990	Mielnicki		
D328,380 S	7/1992	Skomski		
D395,126 S	6/1998	VonZwehl		
D454,999 S	3/2002	Villafana		
D459,856 S *	7/2002	Ghirelli	.....	D99/26
D474,872 S	5/2003	Sullivan		
D494,729 S *	8/2004	Portney	.....	D99/26
D506,943 S	7/2005	Erickson		

FIG. 1 is a front elevational view of a racecar rosary, showing my new design;

FIG. 2 is a perspective view of a single racecar bead thereof, the remaining portion of the rosary being omitted for ease of illustration;

FIG. 3 is a top plan view thereof;

FIG. 4 is a left-side elevational view thereof, the right-side elevational view being a mirror image thereof;

FIG. 5 is a front elevational view thereof;

FIG. 6 is a rear elevational view thereof; and,

FIG. 7 is a bottom plan view thereof.

The broken lines showing beads and a cross in FIG. 1 are included for the purpose of illustrating the invention in use, and form no part of the claimed design.

**1 Claim, 3 Drawing Sheets**

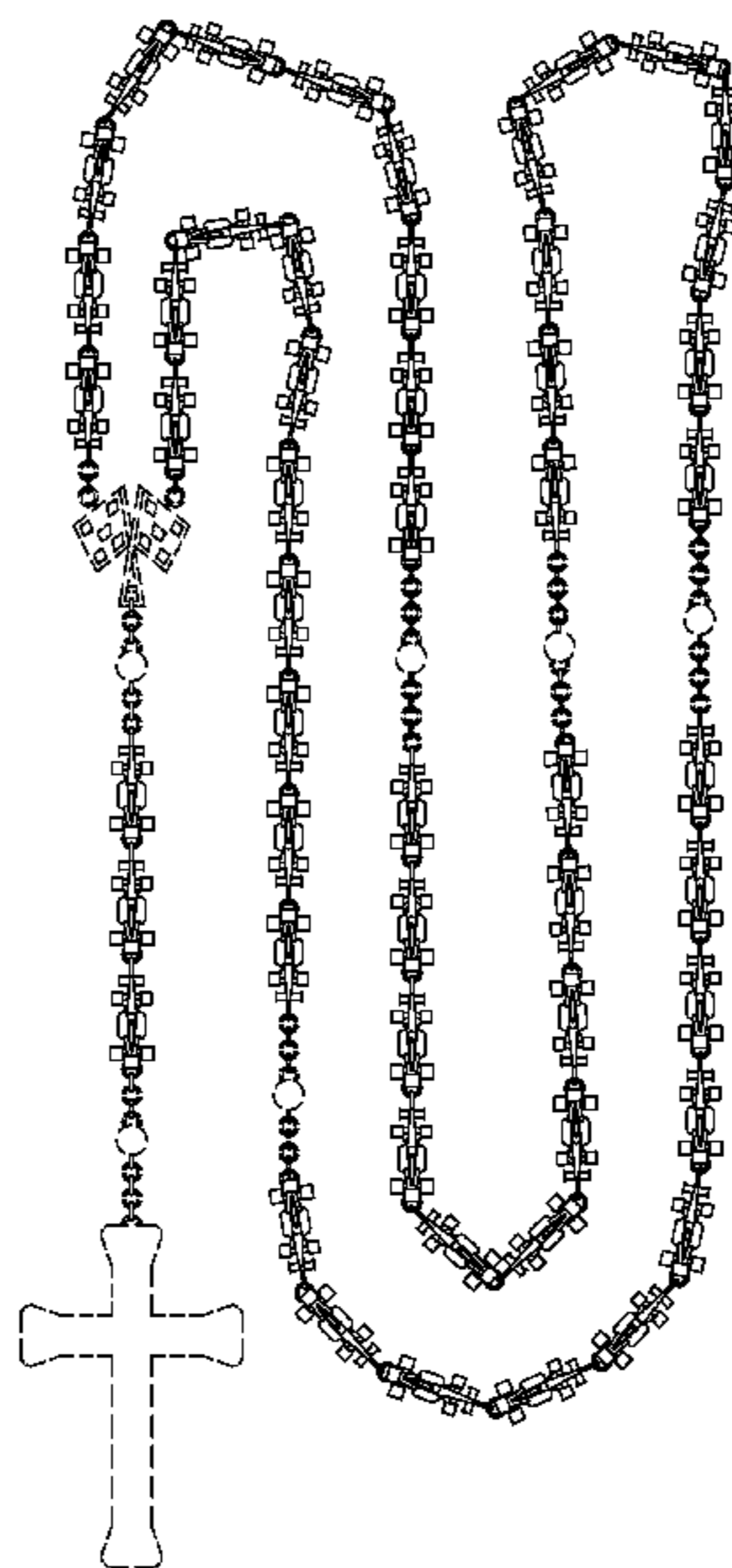

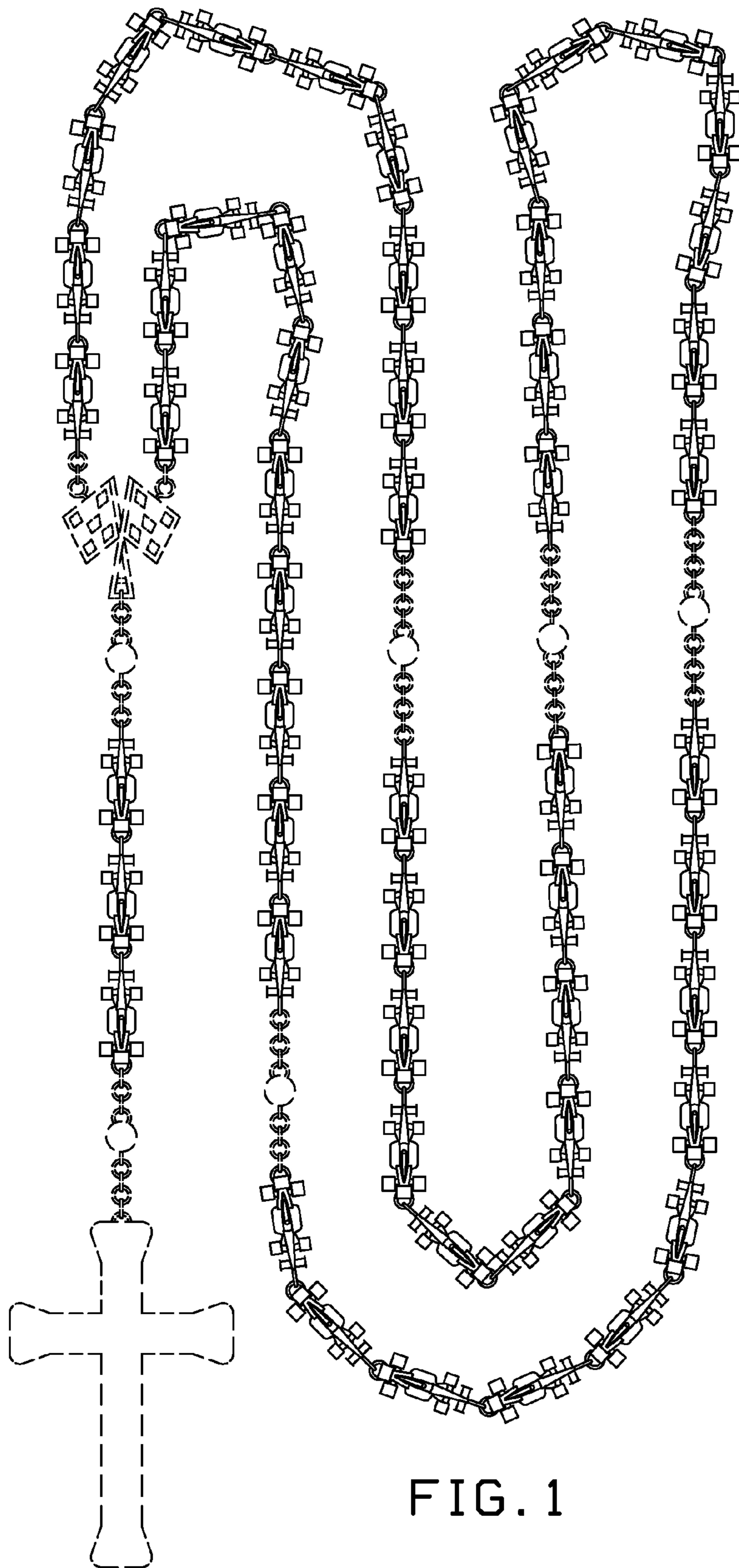

FIG. 1

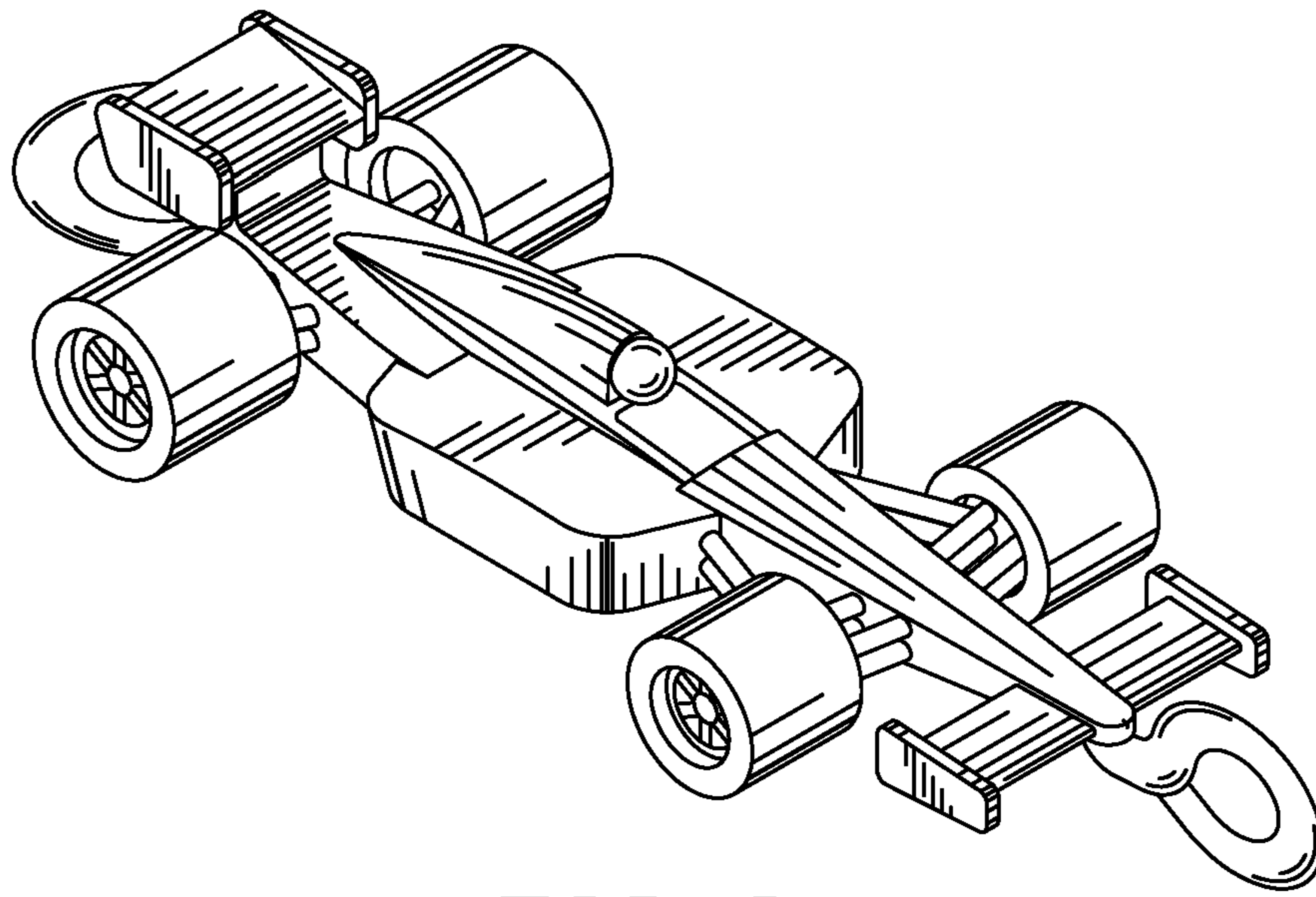

FIG. 2

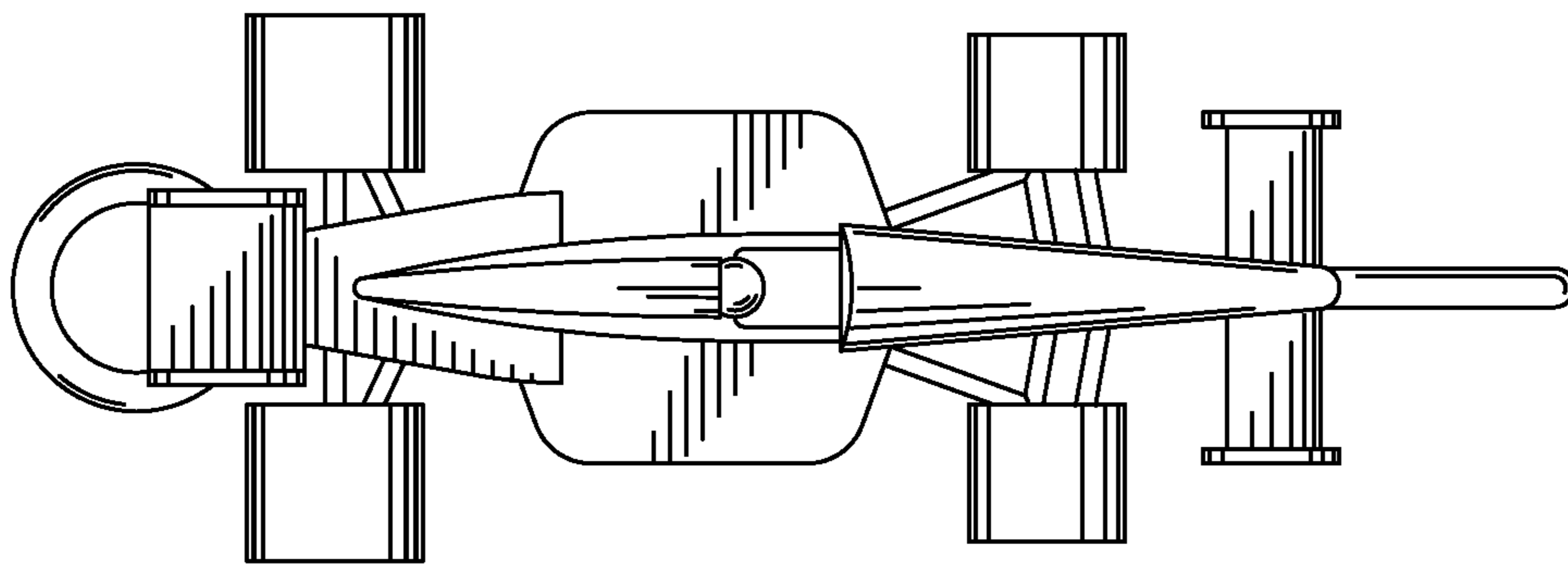

FIG. 3

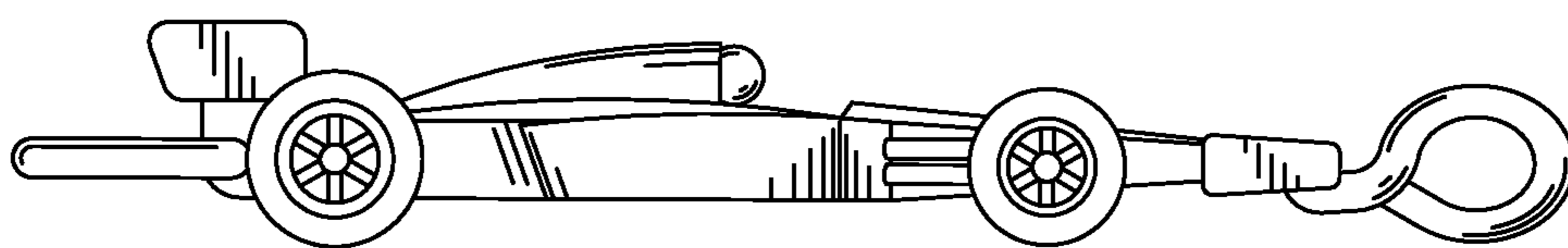

FIG. 4

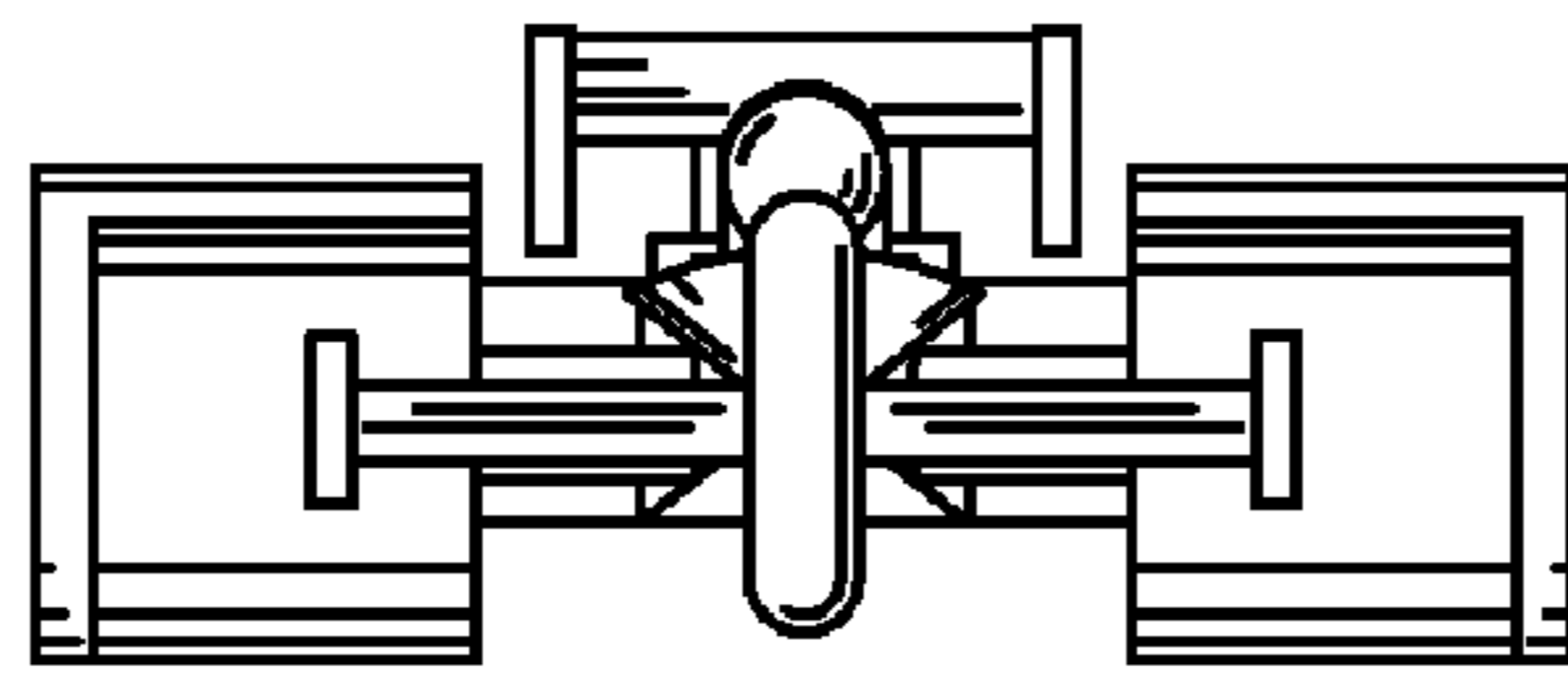

FIG. 5

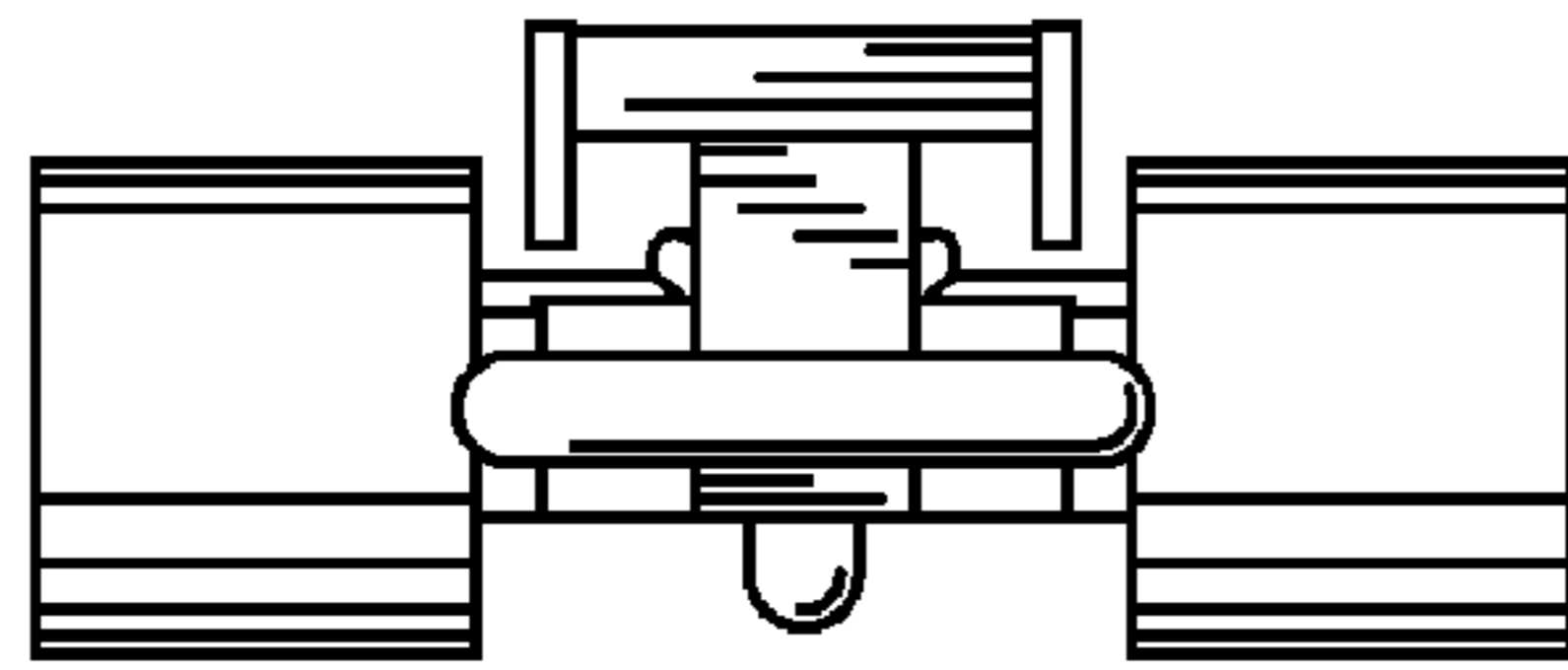

FIG. 6

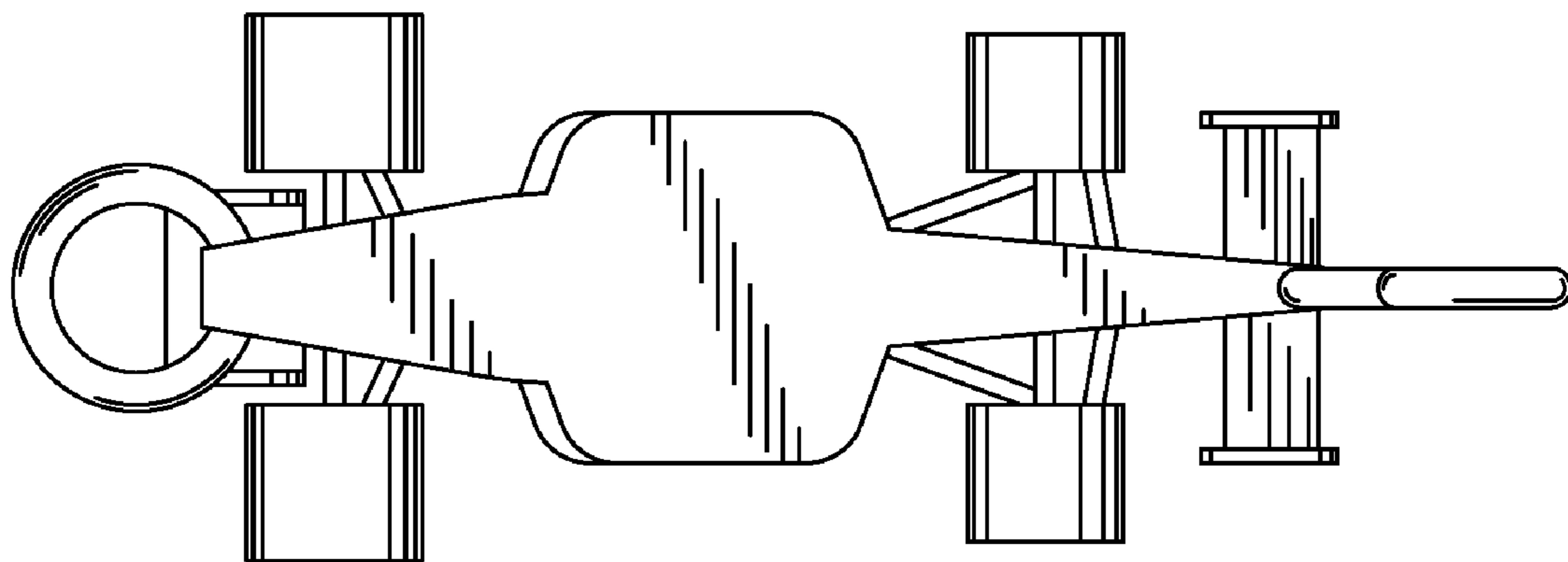

FIG. 7