



US00D612123S

(12) **United States Design Patent**  
**Lawrence**

(10) **Patent No.:** **US D612,123 S**

(45) **Date of Patent:** **\*\* Mar. 16, 2010**

(54) **CART**

(76) **Inventor:** **Ralph G. Lawrence**, 90 Wood Cove Dr.,  
Coventry, RI (US) 02816

(\*\*) **Term:** **14 Years**

(21) **Appl. No.:** **29/340,806**

(22) **Filed:** **Jul. 27, 2009**

(51) **LOC (9) Cl.** ..... **12-02**

(52) **U.S. Cl.** ..... **D34/24**

(58) **Field of Classification Search** ..... D34/12-27;  
248/99, 129, 95; 280/47.19, 47.26, 47.33;  
414/444, 448, 546, 469

See application file for complete search history.

(56) **References Cited**

**U.S. PATENT DOCUMENTS**

3,479,047	A *	11/1969	Bailey	.....	280/47.19
4,179,132	A *	12/1979	Rich	.....	280/47.26
D351,700	S *	10/1994	Uzelman	.....	D34/5
D356,410	S *	3/1995	Cole	.....	D34/15
D393,131	S *	3/1998	Scandalis	.....	D34/24
D411,361	S *	6/1999	Villarreal	.....	D34/24
D447,847	S *	9/2001	Shyshka et al.	.....	D34/21
D463,649	S *	9/2002	Halstead	.....	D34/24
6,715,723	B2 *	4/2004	Zhu	.....	248/129

2005/0103950	A1 *	5/2005	Joubert	.....	248/98
2008/0197587	A1 *	8/2008	Nowak	.....	280/30
2008/0224431	A1 *	9/2008	Reinicke	.....	280/47.26

\* cited by examiner

*Primary Examiner*—Cynthia E Ramirez

(74) *Attorney, Agent, or Firm*—Lackebach Siegel, LLP;  
Andrew F. Young

(57) **CLAIM**

The ornamental design for a cart, as shown and described.

**DESCRIPTION**

FIG. 1 is a front perspective view of a cart of the present invention.

FIG. 2 is a right side elevation view of the present invention.

FIG. 3 is a left side elevation view of the present invention.

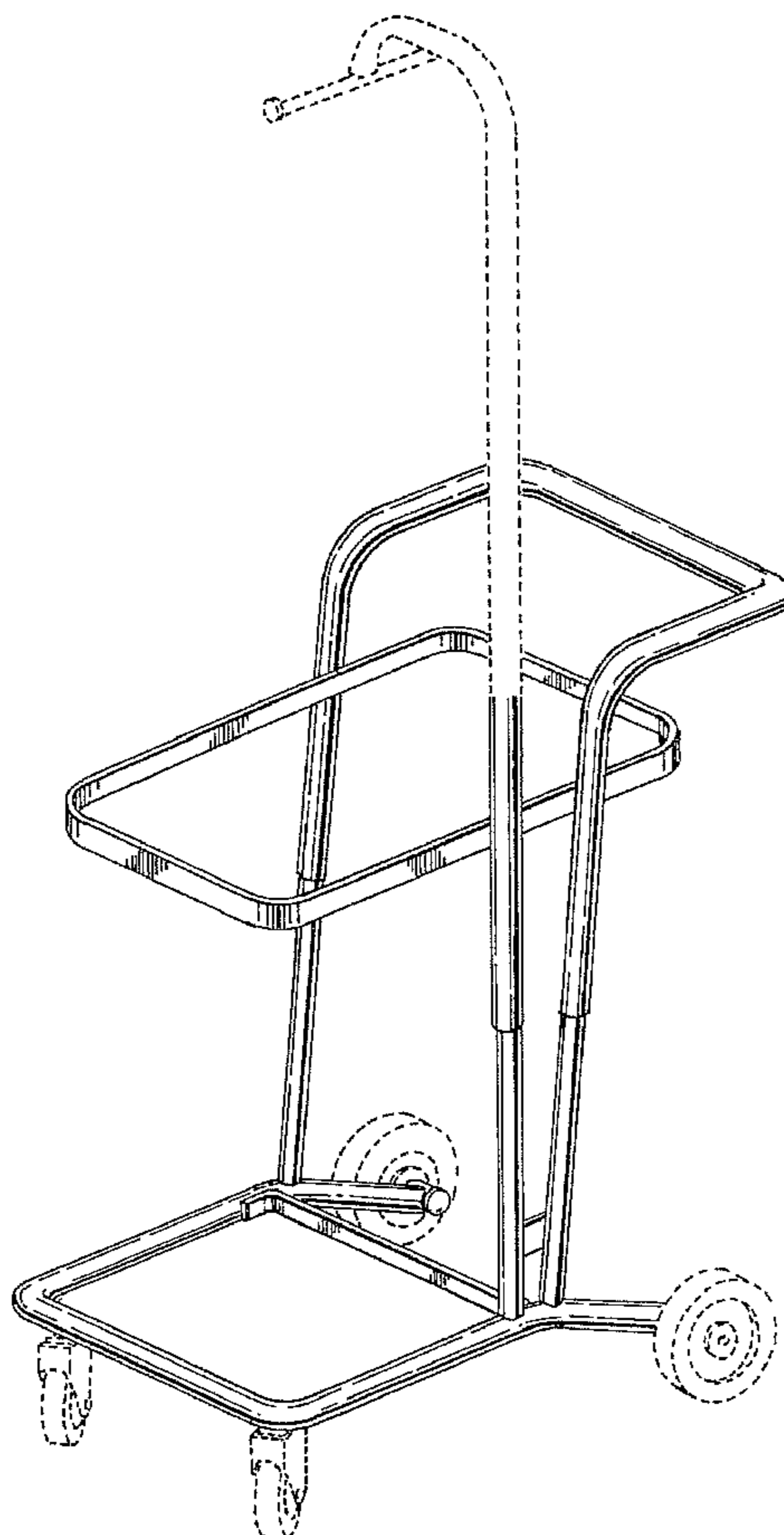
FIG. 4 is a front elevation view of the present invention.

FIG. 5 is a rear elevation view of the present invention; and,

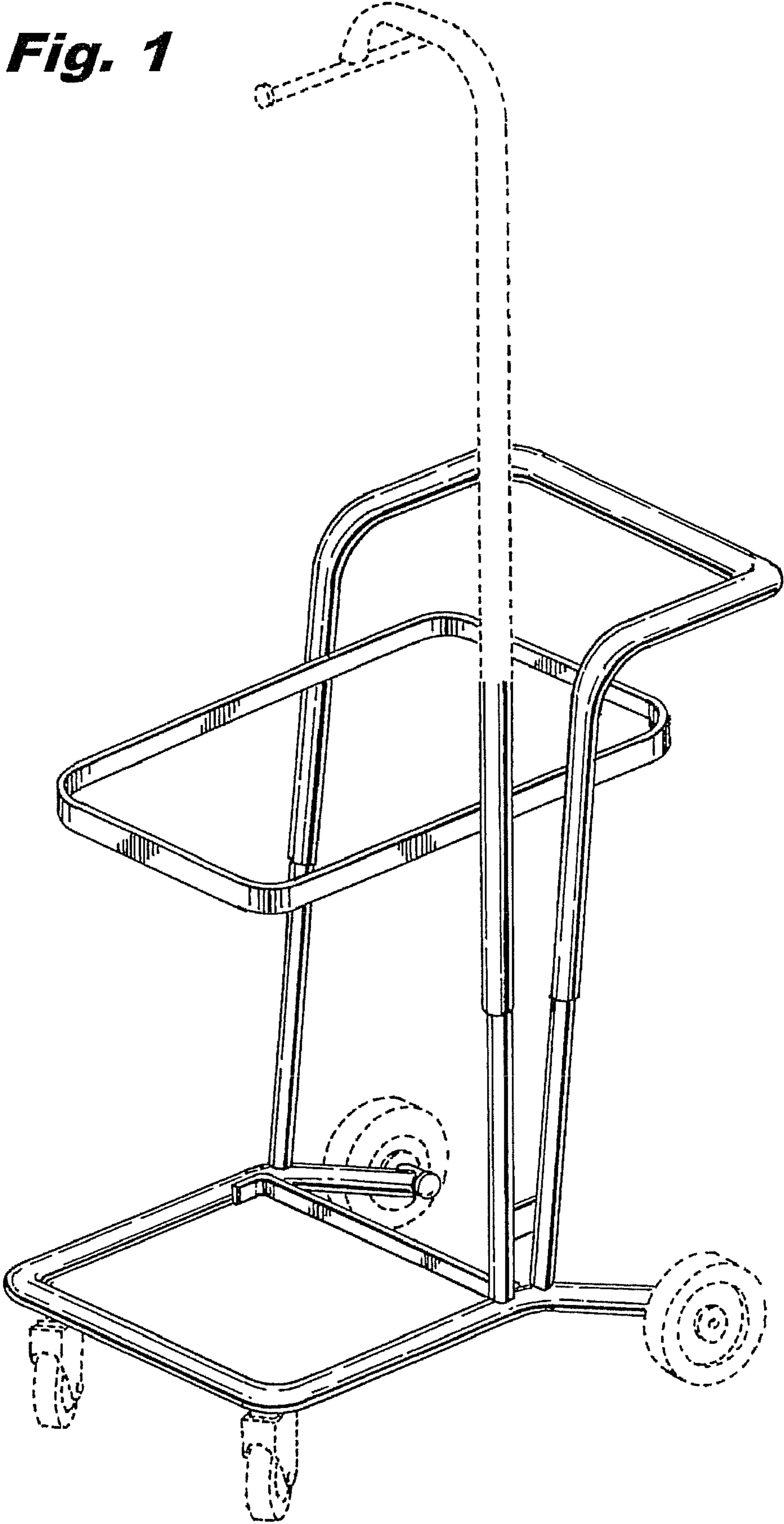
FIG. 6 is a top plan view of the present invention.

The broken lines showing the wheels and support structure is for illustrative purposes only and forms no part of the claimed design.

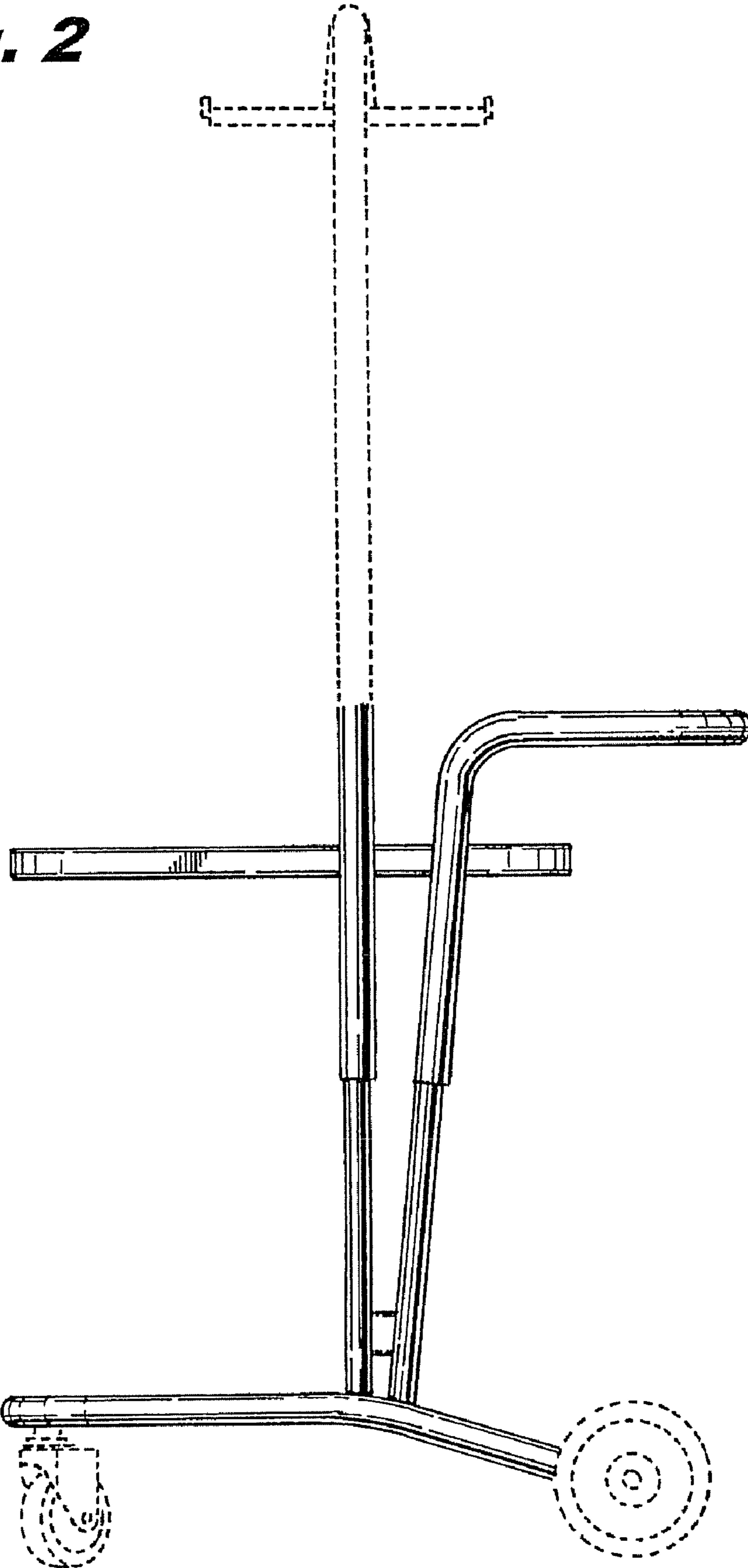
**1 Claim, 6 Drawing Sheets**



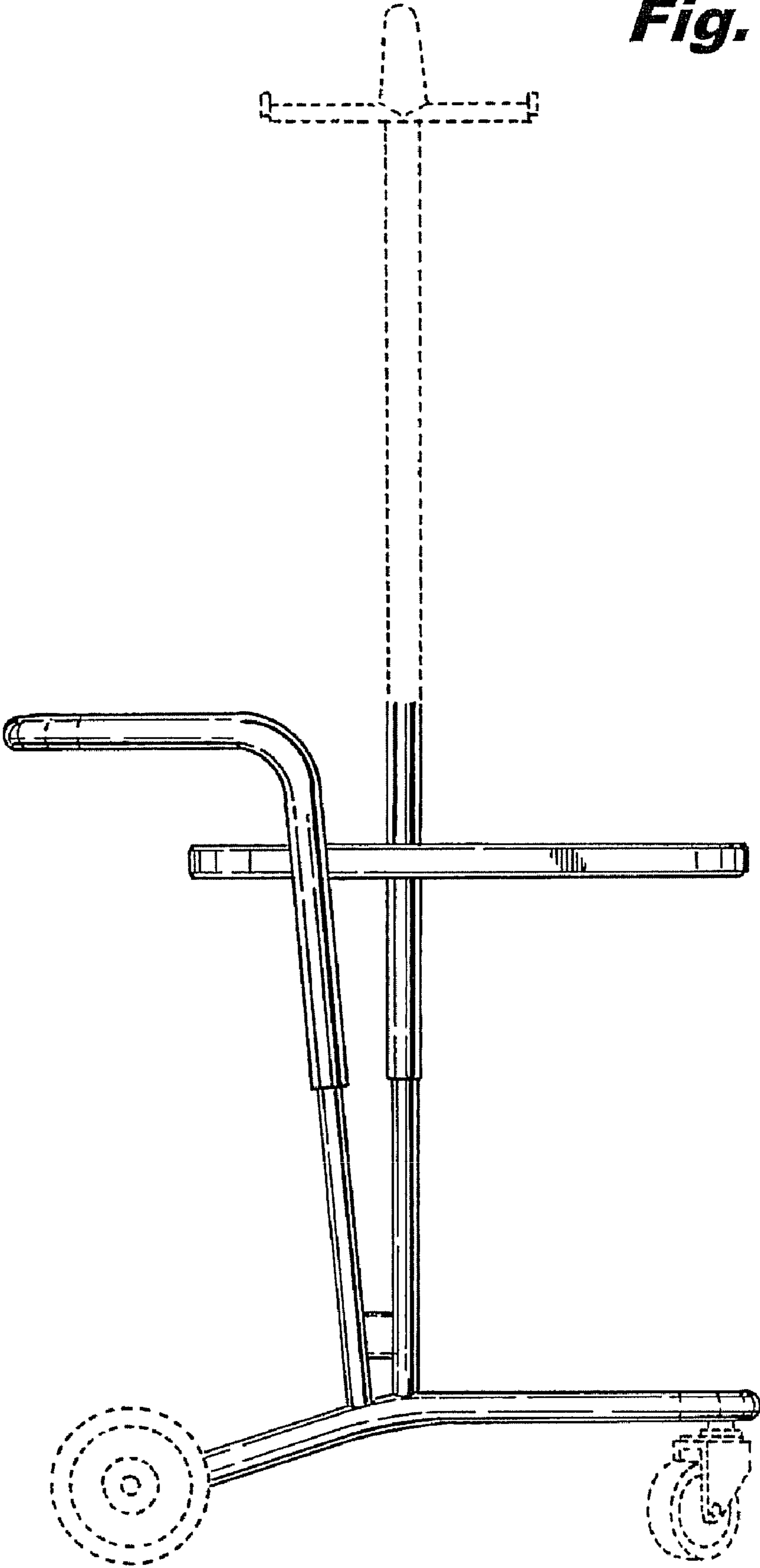
**Fig. 1**



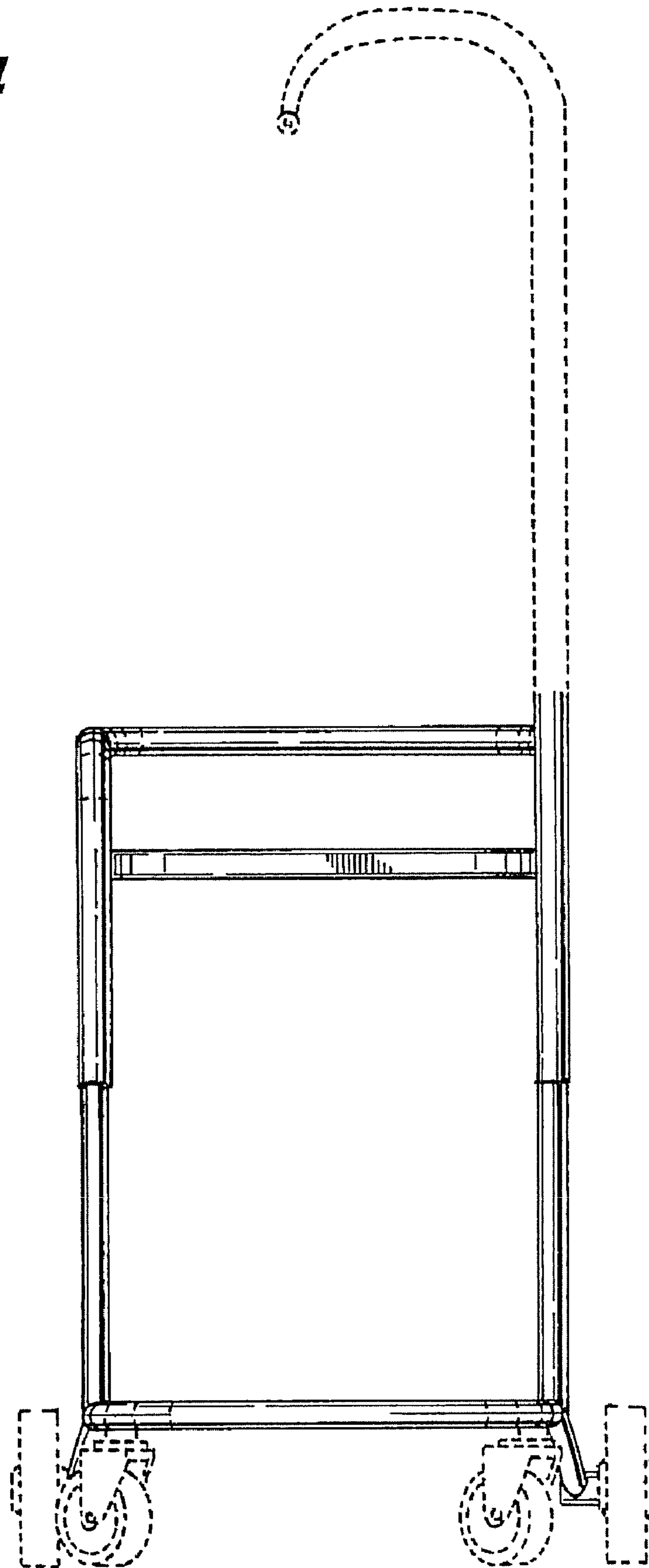
**Fig. 2**

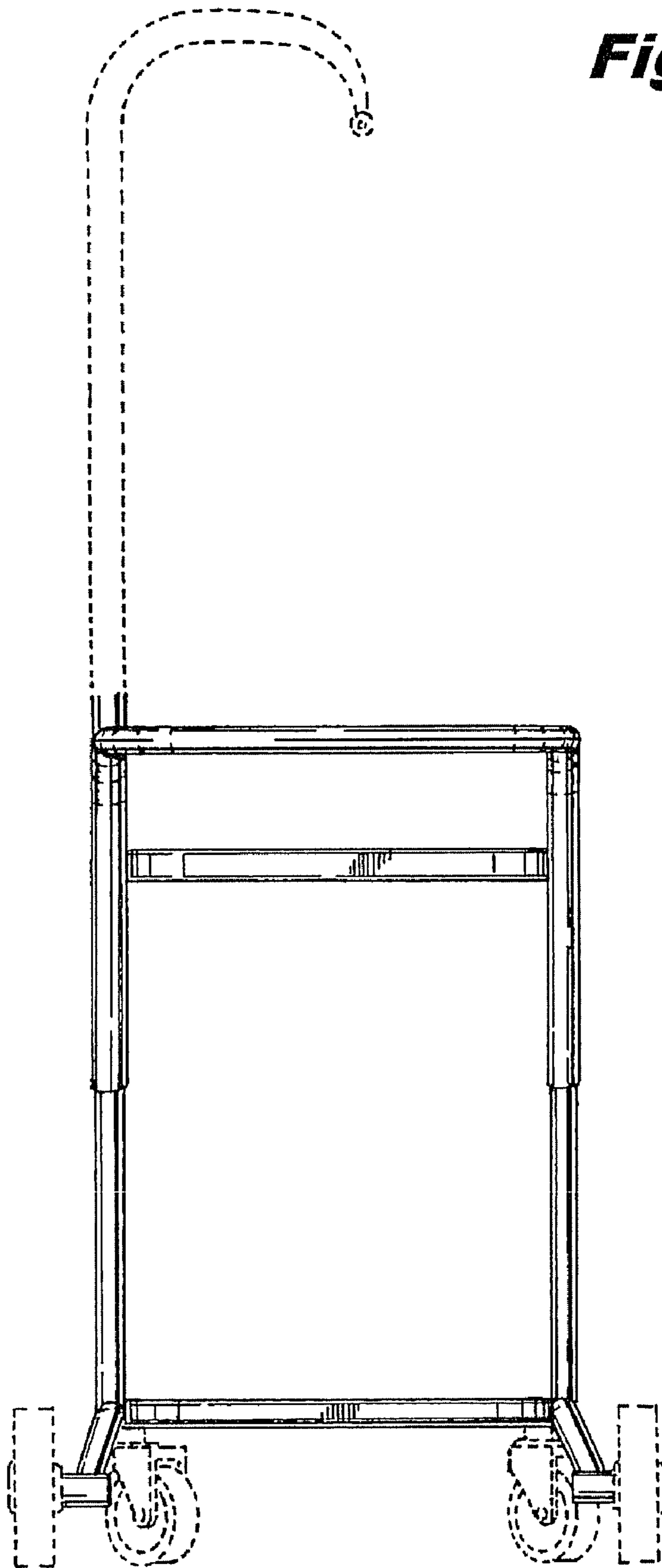


**Fig. 3**



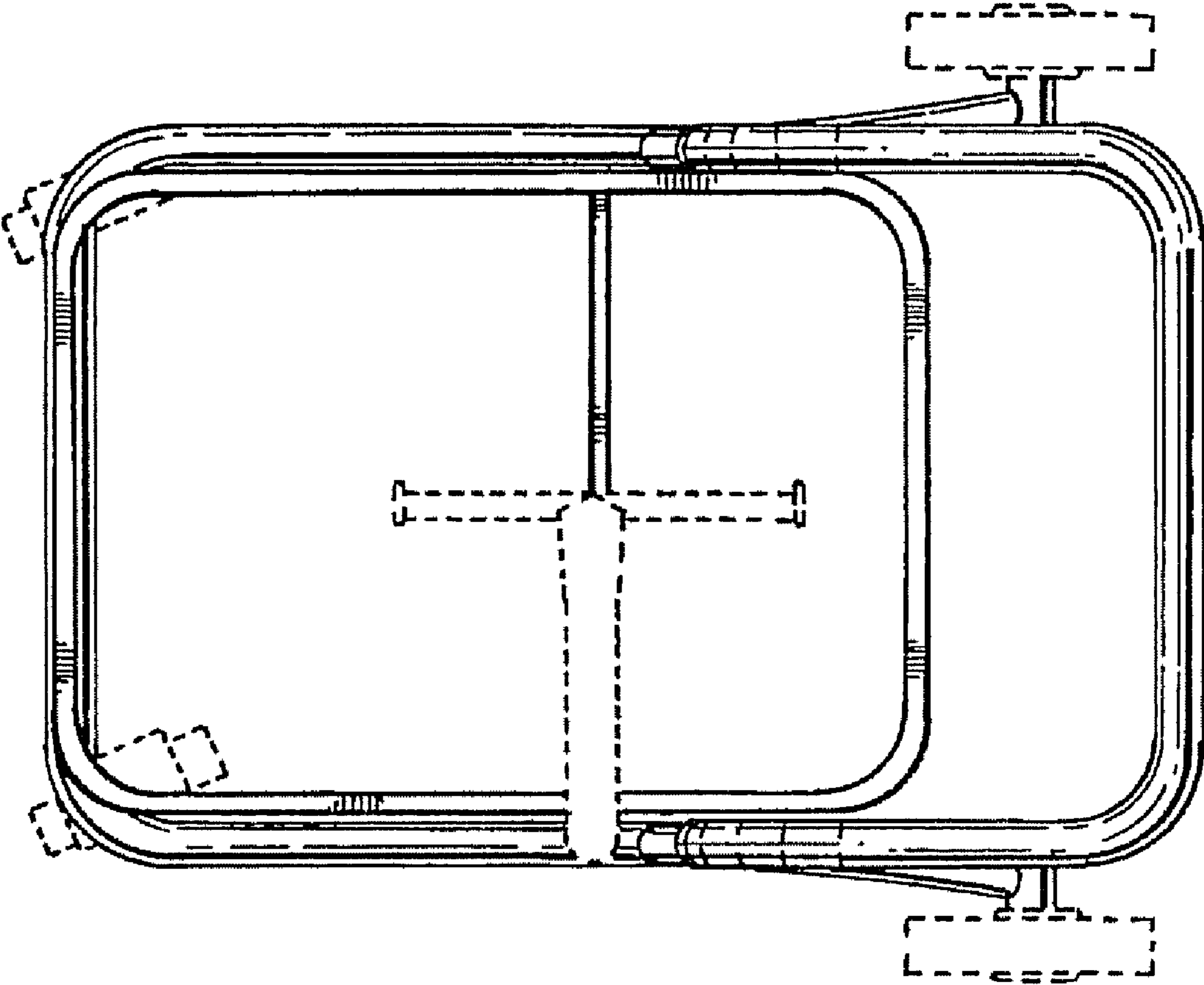
**Fig. 4**





**Fig. 5**





**Fig. 6**