



US00D612087S

(12) **United States Design Patent**  
**Huang**

(10) **Patent No.:** **US D612,087 S**  
(45) **Date of Patent:** **\*\* Mar. 16, 2010**

(54) **TABLE LAMP**

(76) Inventor: **Huo-Tu Huang**, No. 9, Lane 379,  
Chung-Hwa Rd., Su Lin, Taipei County  
(TW)

(\*\*) Term: **14 Years**

(21) Appl. No.: **29/309,625**

(22) Filed: **Sep. 15, 2008**

(51) **LOC (9) Cl.** ..... **26-05**

(52) **U.S. Cl.** ..... **D26/63; D26/65**

(58) **Field of Classification Search** ..... D26/61-65,  
D26/107; 362/269, 275, 285, 371, 410, 413,  
362/414, 418, 419, 427

See application file for complete search history.

(56) **References Cited**

**U.S. PATENT DOCUMENTS**

|              |         |                   |       |        |
|--------------|---------|-------------------|-------|--------|
| D365,648 S * | 12/1995 | Yuen              | ..... | D26/65 |
| D382,362 S * | 8/1997  | Huang             | ..... | D26/65 |
| D402,385 S * | 12/1998 | Chen              | ..... | D26/65 |
| D441,476 S * | 5/2001  | Mendelsohn et al. | ..... | D26/63 |
| D467,378 S * | 12/2002 | Wang              | ..... | D26/65 |
| D484,998 S * | 1/2004  | Cvek              | ..... | D26/65 |
| D564,118 S * | 3/2008  | Wu                | ..... | D26/63 |

|                   |        |           |       |         |
|-------------------|--------|-----------|-------|---------|
| D567,983 S *      | 4/2008 | Lu et al. | ..... | D26/65  |
| D599,930 S *      | 9/2009 | Huang     | ..... | D26/63  |
| D600,388 S *      | 9/2009 | Huang     | ..... | D26/65  |
| 2004/0105271 A1 * | 6/2004 | Chen      | ..... | 362/402 |

\* cited by examiner

*Primary Examiner*—Clare E Heflin

(74) *Attorney, Agent, or Firm*—Bacon & Thomas, PLLC

(57) **CLAIM**

I claim the ornamental design for table lamp, as shown and described.

**DESCRIPTION**

FIG. 1. is a perspective view of table lamp showing my new design

FIG. 2. is a front elevational view thereof;

FIG. 3. is a rear elevational view thereof;

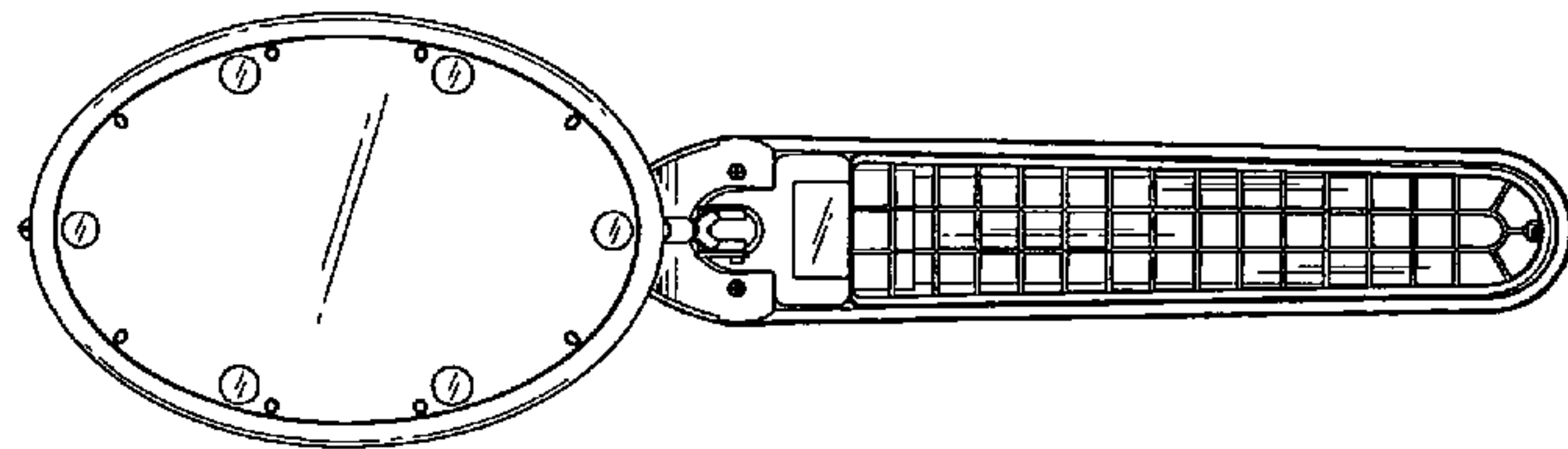
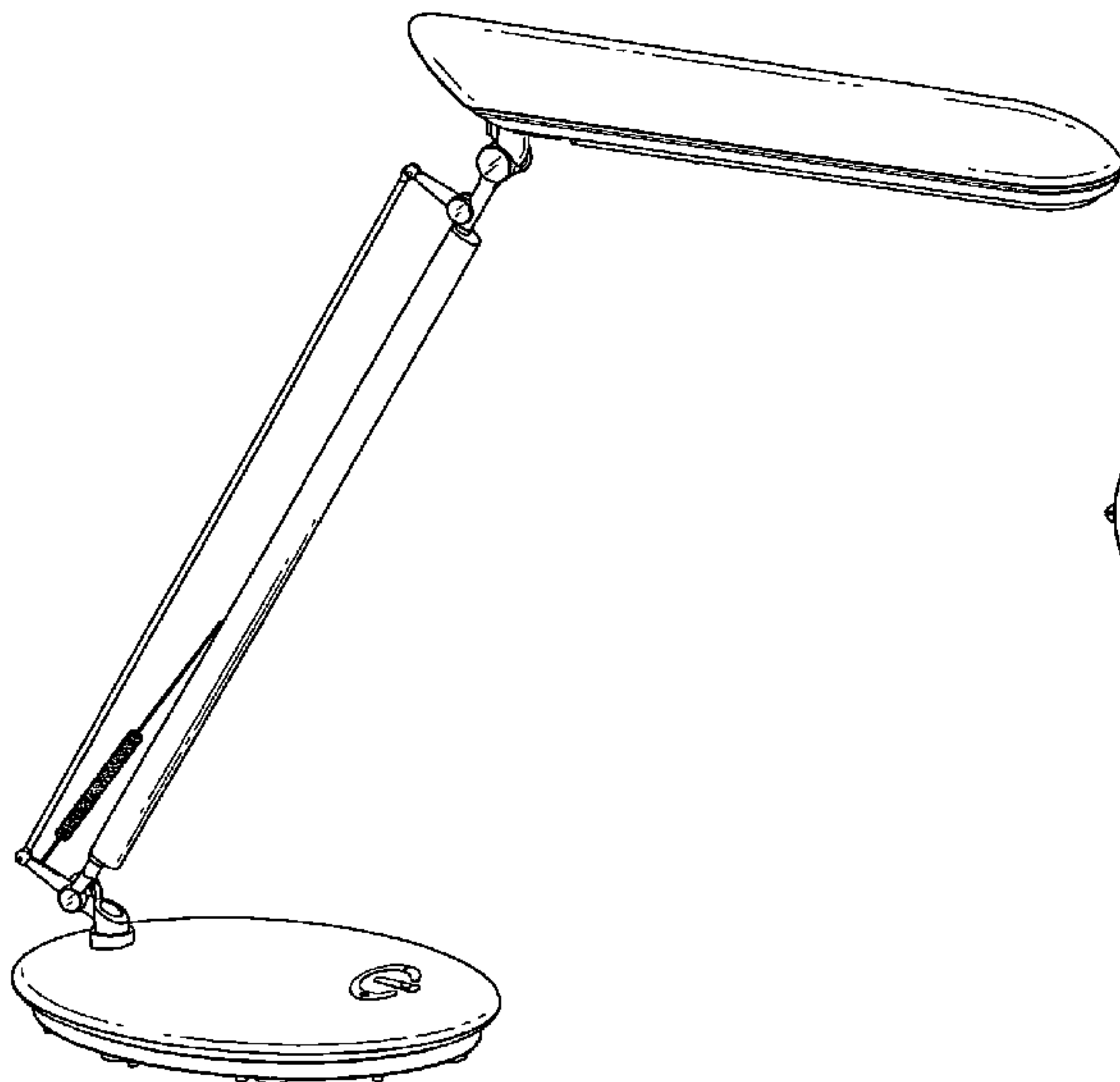
FIG. 4. is a left side elevational view thereof;

FIG. 5. is a right side elevational view thereof;

FIG. 6. is a top plan view thereof; and,

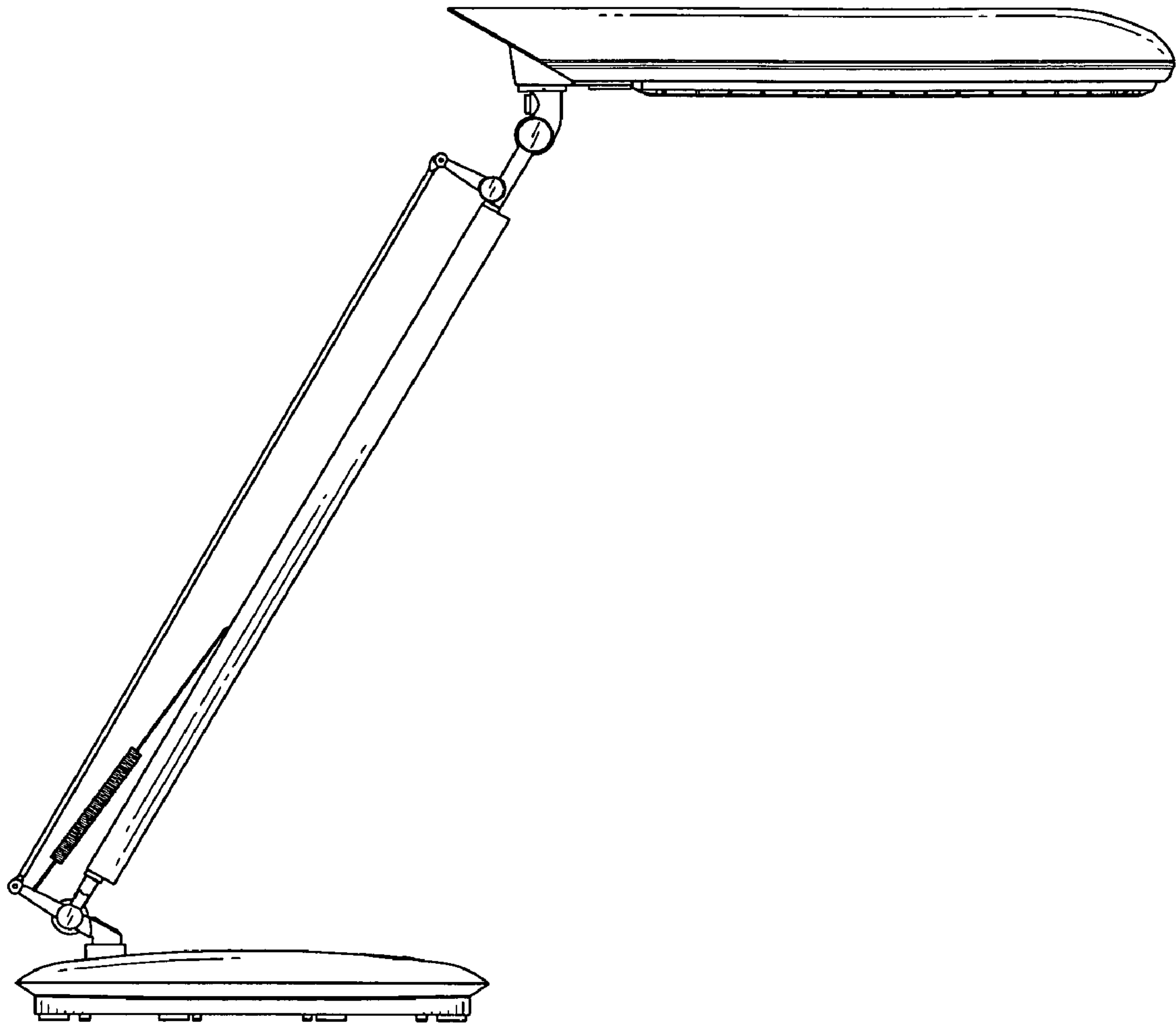
FIG. 7. is a bottom plan view thereof.

**1 Claim, 5 Drawing Sheets**

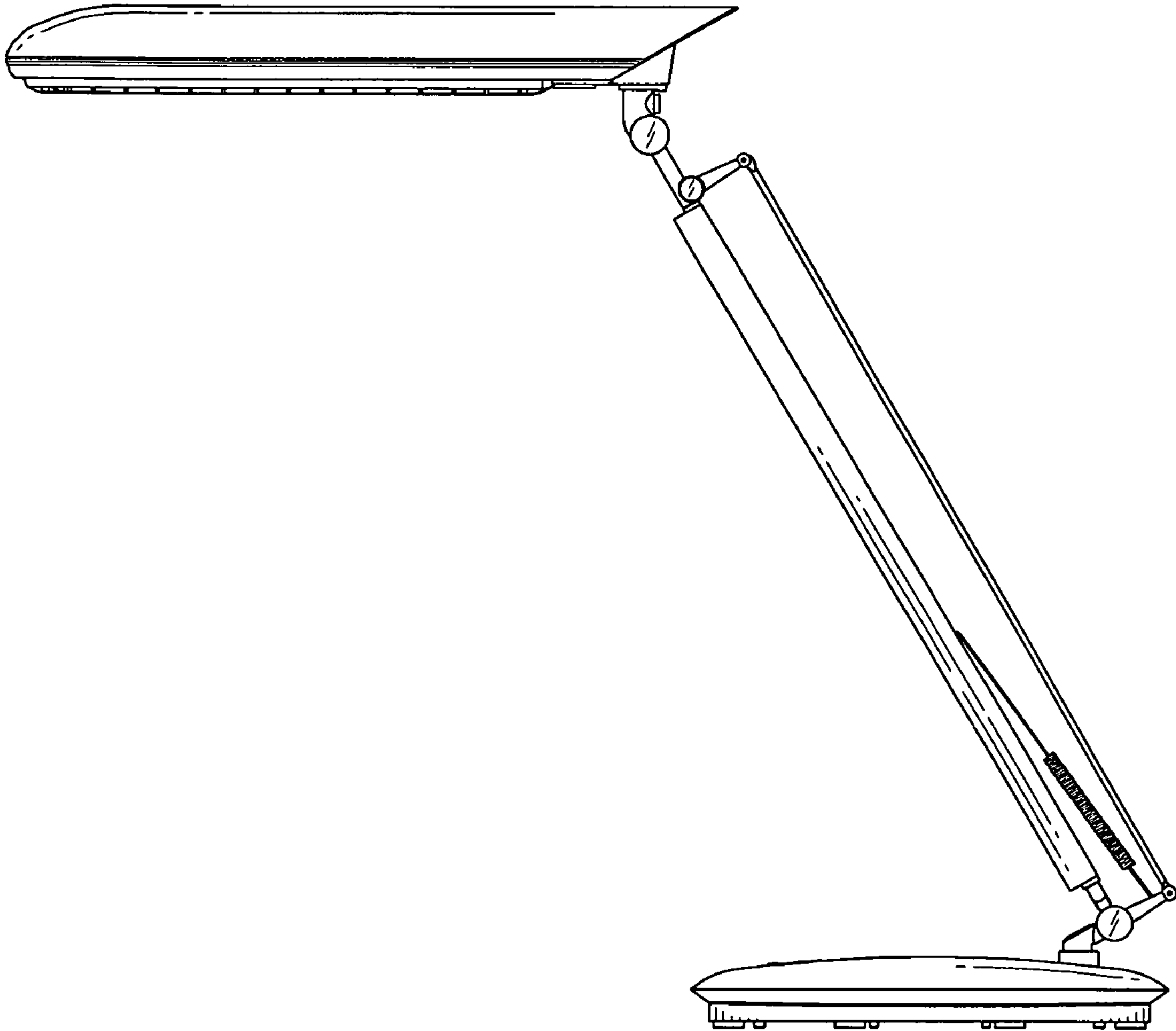




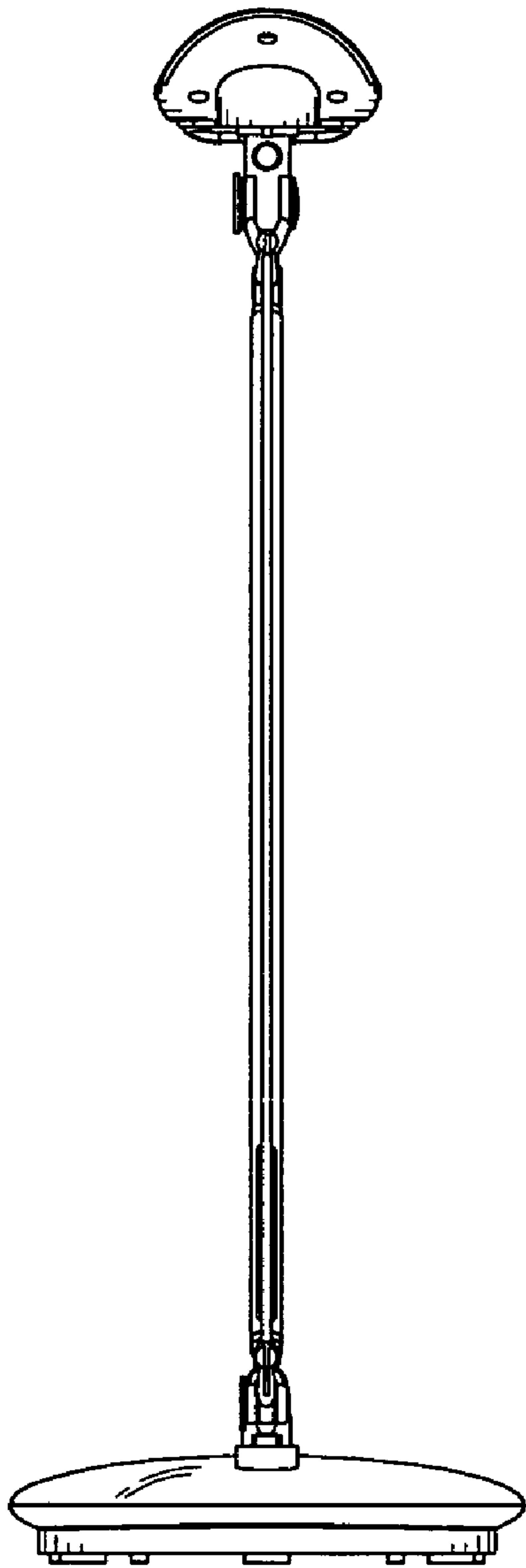
**FIG. 1**



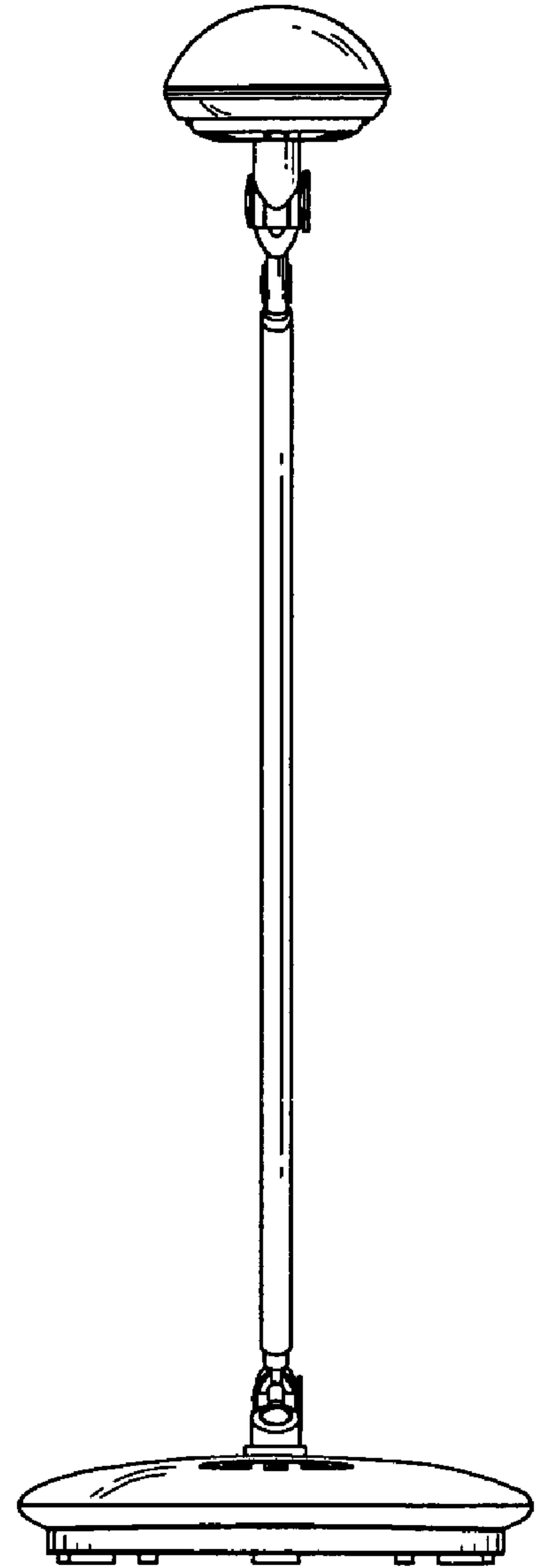
*FIG. 2*



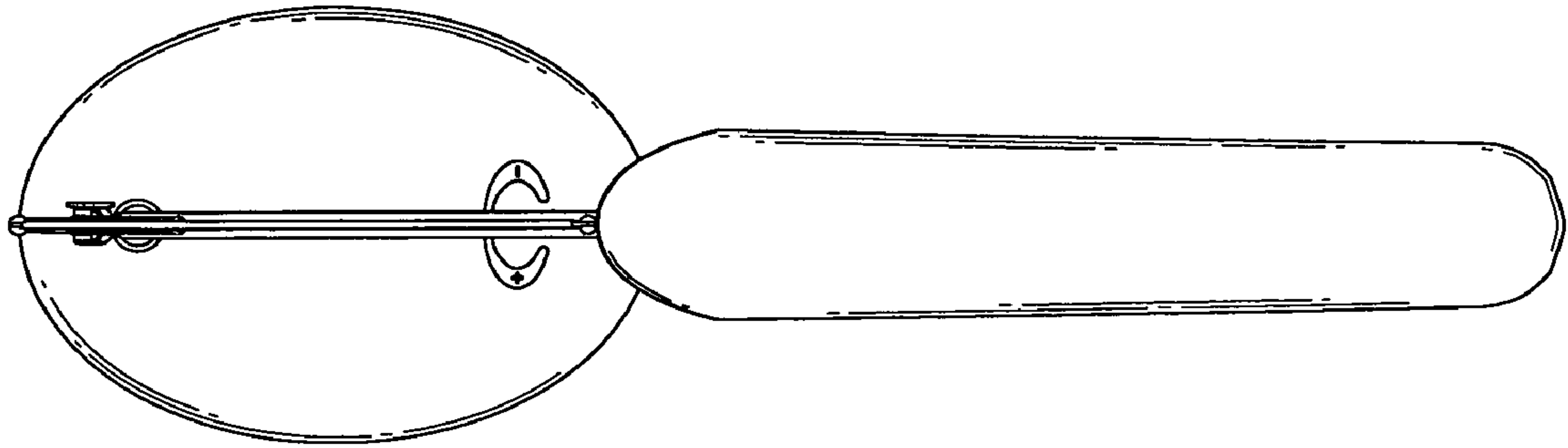
**FIG. 3**



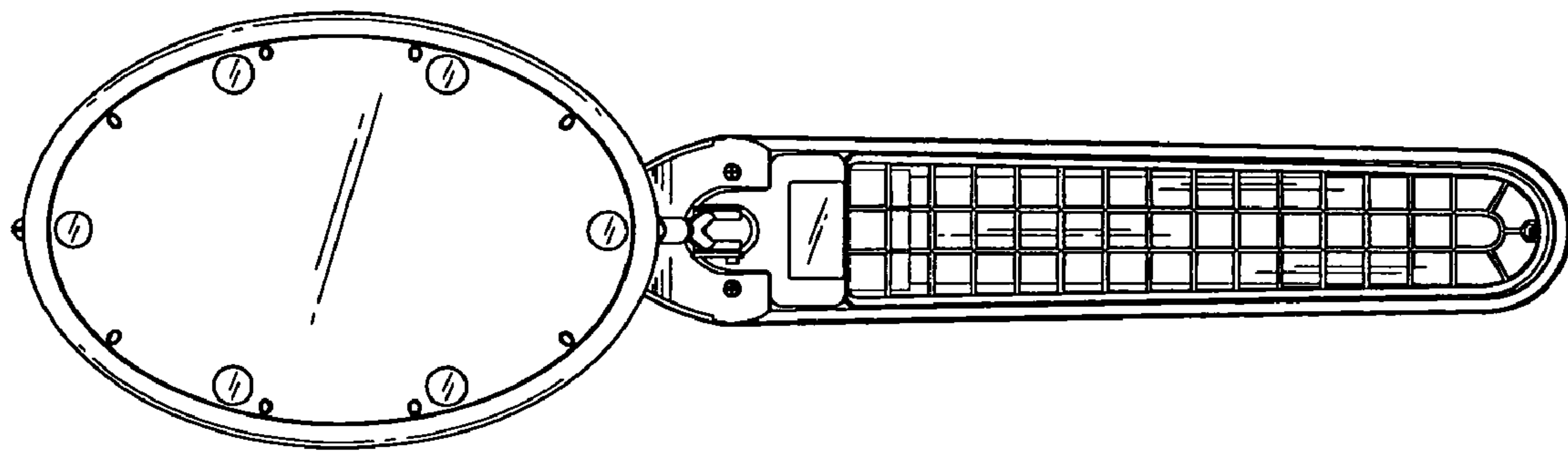
*FIG. 4*



*FIG. 5*



**FIG. 6**



**FIG. 7**