

US00D612049S

(12) **United States Design Patent**
Baynham

(10) **Patent No.:** **US D612,049 S**
(45) **Date of Patent:** **** Mar. 16, 2010**

(54) **DELAMINATOR**

(75) Inventor: **Matthew G. Baynham**, Jupiter, FL (US)

(73) Assignee: **Atlas Spine, Inc.**, Jupiter, FL (US)

(**) Term: **14 Years**

(21) Appl. No.: **29/319,341**

(22) Filed: **Jun. 6, 2008**

(51) **LOC (9) Cl.** **24-02**

(52) **U.S. Cl.** **D24/146; D24/133; D24/147**

(58) **Field of Classification Search** D24/133,
D24/135, 140, 144, 146-147, 149; 606/79,
606/84-85, 160, 131, 161, 170, 171, 177,
606/83, 51-52, 205, 86 R, 39, 132; D28/57,
D28/59; D8/94

See application file for complete search history.

(56) **References Cited**

U.S. PATENT DOCUMENTS

343,136	A *	6/1886	Moore	76/82
D30,996	S *	6/1899	Chechelski	D8/90
1,002,468	A *	9/1911	Strangman	601/141
4,221,222	A *	9/1980	Detsch	606/132
D282,205	S *	1/1986	Davison et al.	D24/149
D282,238	S *	1/1986	Kenna	D8/94
4,625,725	A *	12/1986	Davison et al.	606/85
D302,297	S *	7/1989	Chechelski	D24/147
D325,970	S *	5/1992	Rubin	D24/147
5,342,365	A *	8/1994	Waldman	606/85
D390,659	S *	2/1998	Chan et al.	D24/133

D590,946	S *	4/2009	Baynham	D24/146
2005/0049705	A1 *	3/2005	Hale et al.	623/17.11
2005/0251146	A1 *	11/2005	Martz et al.	606/84
2006/0200153	A1 *	9/2006	Harp	606/85
2006/0206117	A1 *	9/2006	Harp	606/85
2007/0282441	A1 *	12/2007	Stream et al.	623/17.11

* cited by examiner

Primary Examiner—Ian Simmons

Assistant Examiner—Wan Laymon

(74) *Attorney, Agent, or Firm*—McHale & Slavin, P.A.

(57) **CLAIM**

The ornamental design for a delaminator, as shown and described.

DESCRIPTION

FIG. 1 is a bottom and right perspective view of the delaminator of the instant invention;

FIG. 2 is a left side view thereof;

FIG. 3 is a top view thereof;

FIG. 4 is a bottom view thereof;

FIG. 5 is a right side view thereof;

FIG. 6 is a front end view thereof;

FIG. 7 is a rear end view thereof; and,

FIG. 8 is an enlarged top partial perspective view of the blade portion thereof, with the dashed lines showing the boundary of the figure and forms no part of the claimed design.

1 Claim, 2 Drawing Sheets

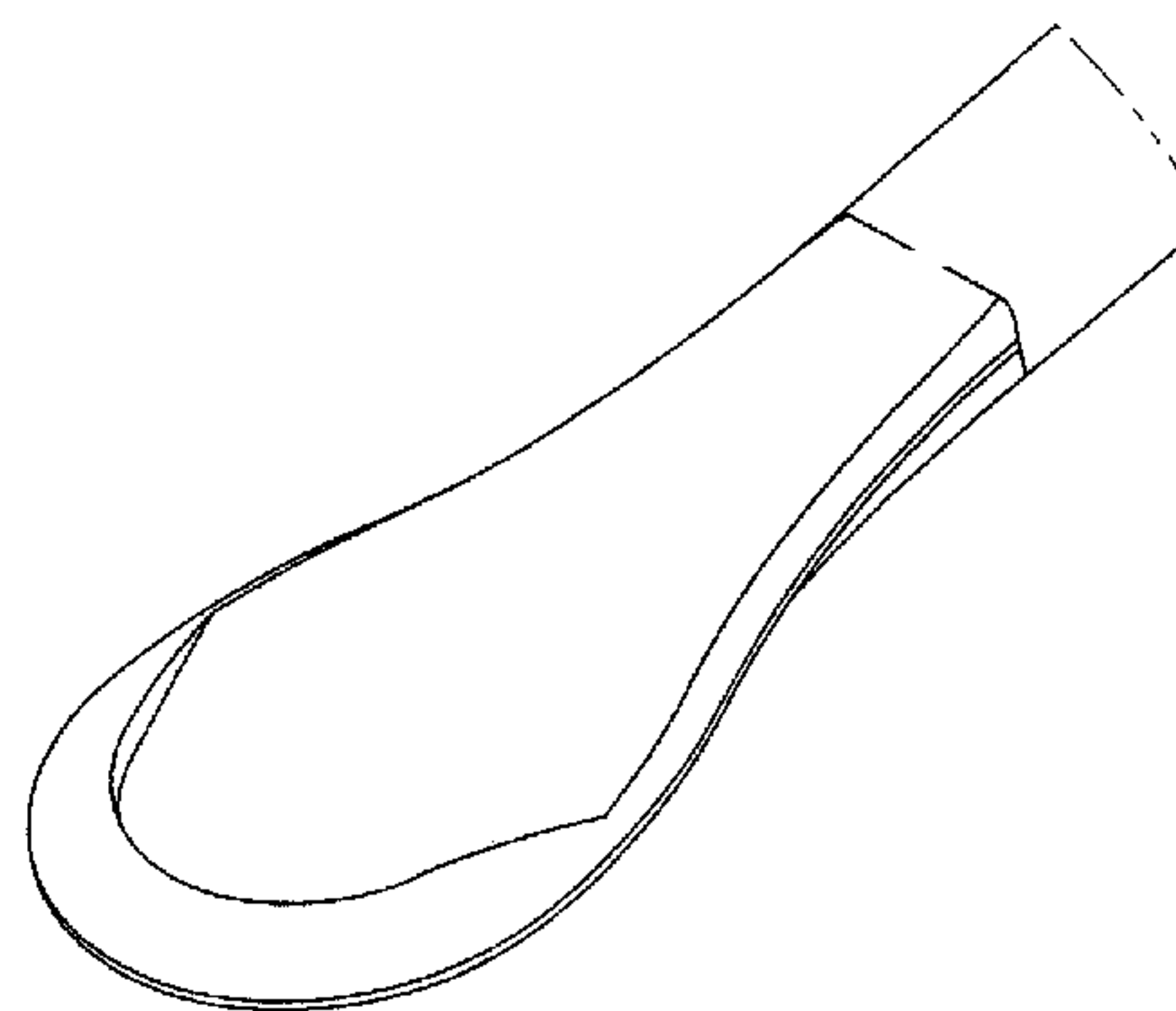
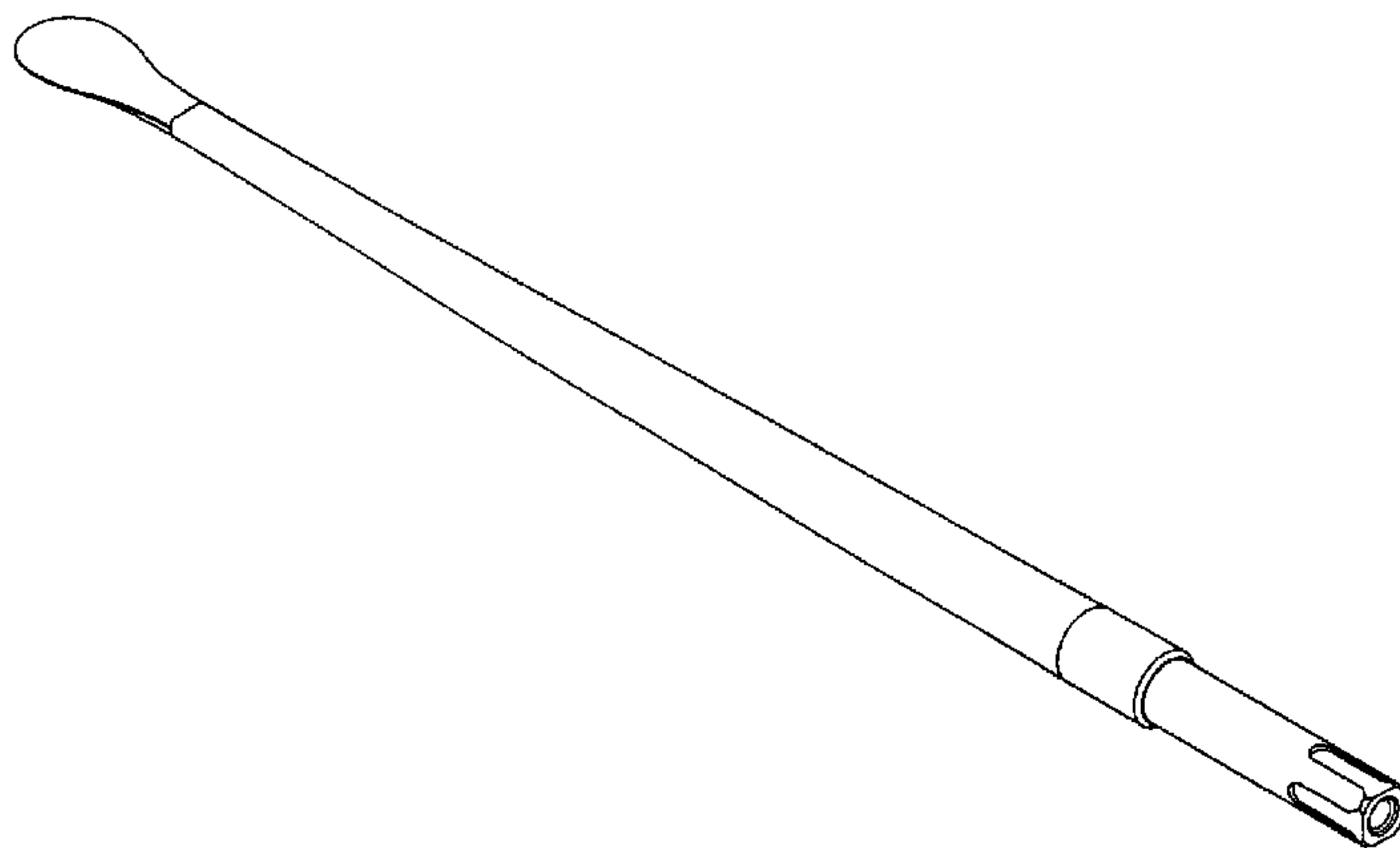

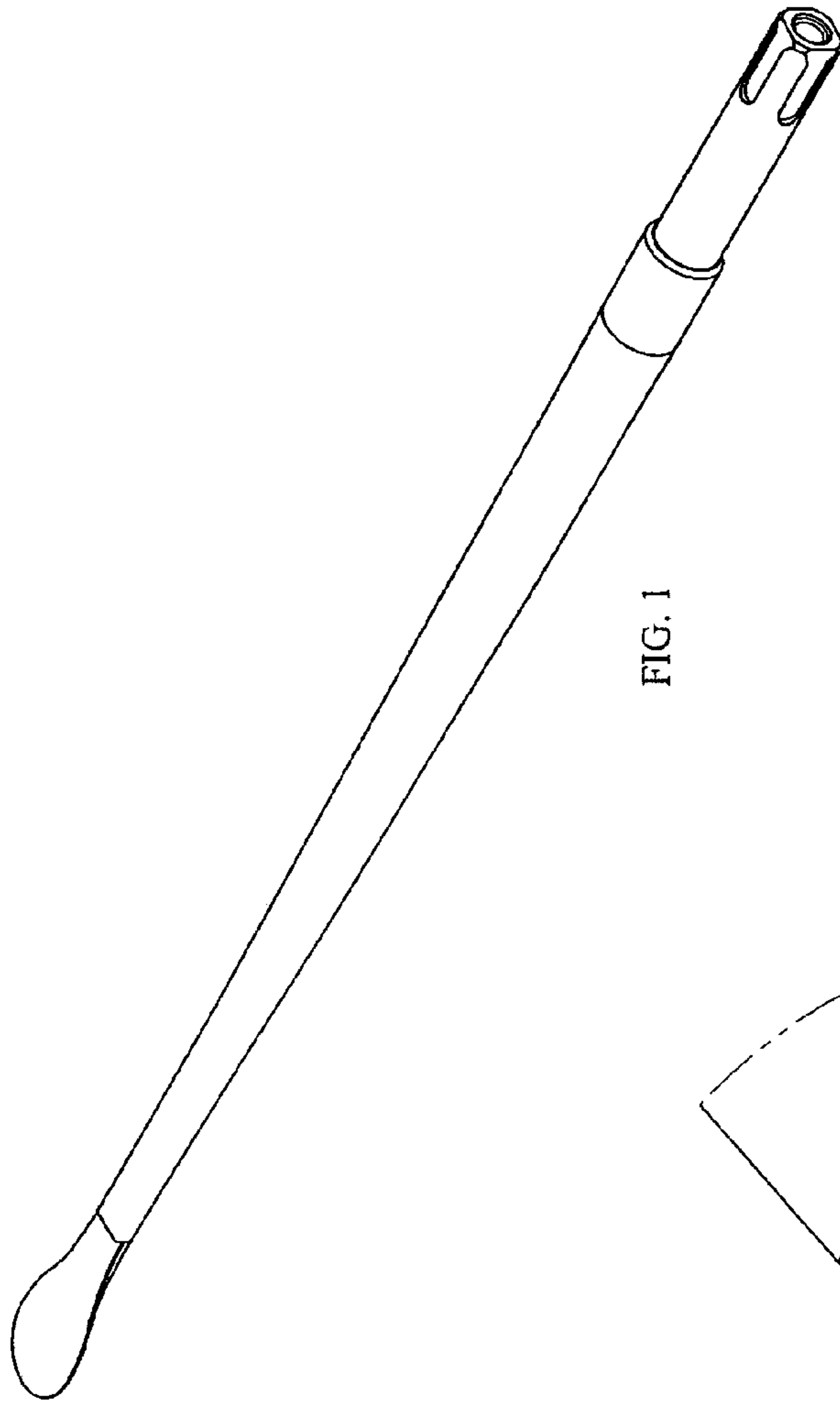

FIG. 1

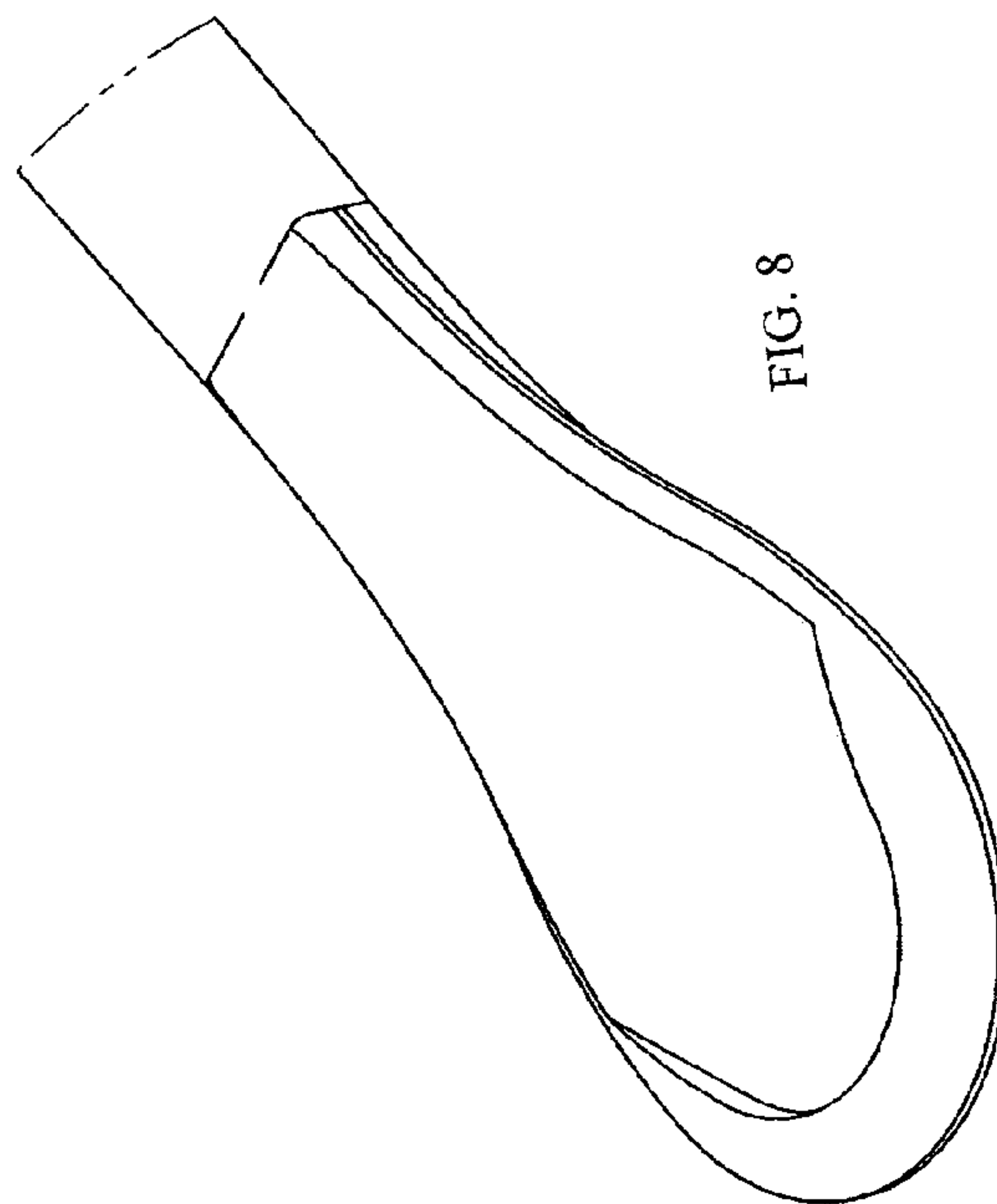

FIG. 8

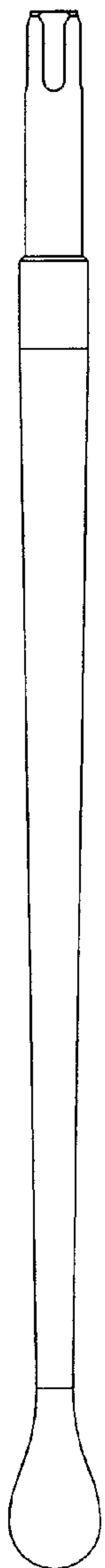

FIG. 4



FIG. 6

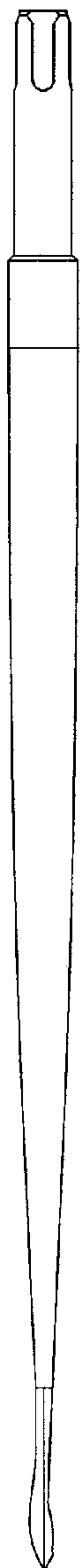

FIG. 5



FIG. 7

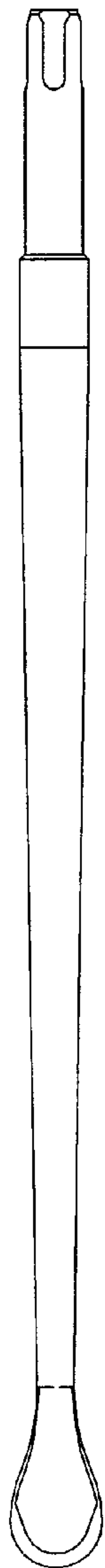

FIG. 3

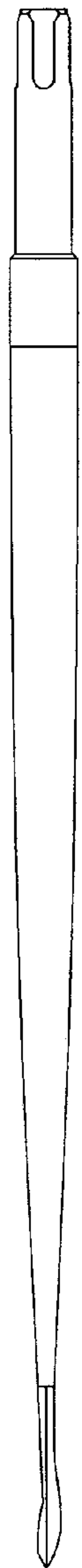

FIG. 2