



US00D612008S

(12) **United States Design Patent**
Schoenherr et al.

(10) **Patent No.:** **US D612,008 S**
(45) **Date of Patent:** **** Mar. 16, 2010**

(54) **SHOWERHEAD**

(75) Inventors: **Tom Schoenherr**, Stuttgart (DE); **Sven Feustel**, Stuttgart (DE)

(73) Assignee: **Hansgrohe AG**, Schiltach (DE)

(**) Term: **14 Years**

(21) Appl. No.: **29/333,843**

(22) Filed: **Mar. 16, 2009**

(30) **Foreign Application Priority Data**

Sep. 26, 2008 (EP) 001011415-0014

(51) **LOC (9) Cl.** **23-01**

(52) **U.S. Cl.** **D23/213; D23/229**

(58) **Field of Classification Search** D23/213,
D23/223, 226, 229-230; 239/525-527, 282-283,
239/460

See application file for complete search history.

(56) **References Cited**

U.S. PATENT DOCUMENTS

D475,433 S * 6/2003 Citterio D23/213
D495,778 S * 9/2004 Jorgensen et al. D23/213
D556,855 S * 12/2007 Mullenmeister et al. ... D23/213
D559,953 S * 1/2008 Bickler et al. D23/229
D565,155 S * 3/2008 Mullenmeister et al. ... D23/229

OTHER PUBLICATIONS

Brochure—Elginkan, 3 pgs., Valfsel Armatur Sanayi A.S., Manisa, Turkey (at least as early as Mar. 9, 2007).

Brochure—Contemporary Mood, Seta . Dive . Ice Cube, 3 pgs., Bandini Rubinetterie, Firenze, Italy (at least as early as Mar. 9, 2007).

* cited by examiner

Primary Examiner—Robin V Webster

(74) *Attorney, Agent, or Firm*—Nirav D. Parikh; Edgar A. Zarins

(57) **CLAIM**

The ornamental design for a showerhead, as shown and described.

DESCRIPTION

FIG. 1 is a perspective view of a showerhead showing our design;

FIG. 2 is a front elevational view thereof;

FIG. 3 is a left side elevational view thereof; the right side elevational view being a mirror image thereof;

FIG. 4 is a top plan view thereof; and,

FIG. 5 is a bottom plan view thereof.

The broken lines in the drawings represent unclaimed portions of the design and form no part thereof.

1 Claim, 5 Drawing Sheets

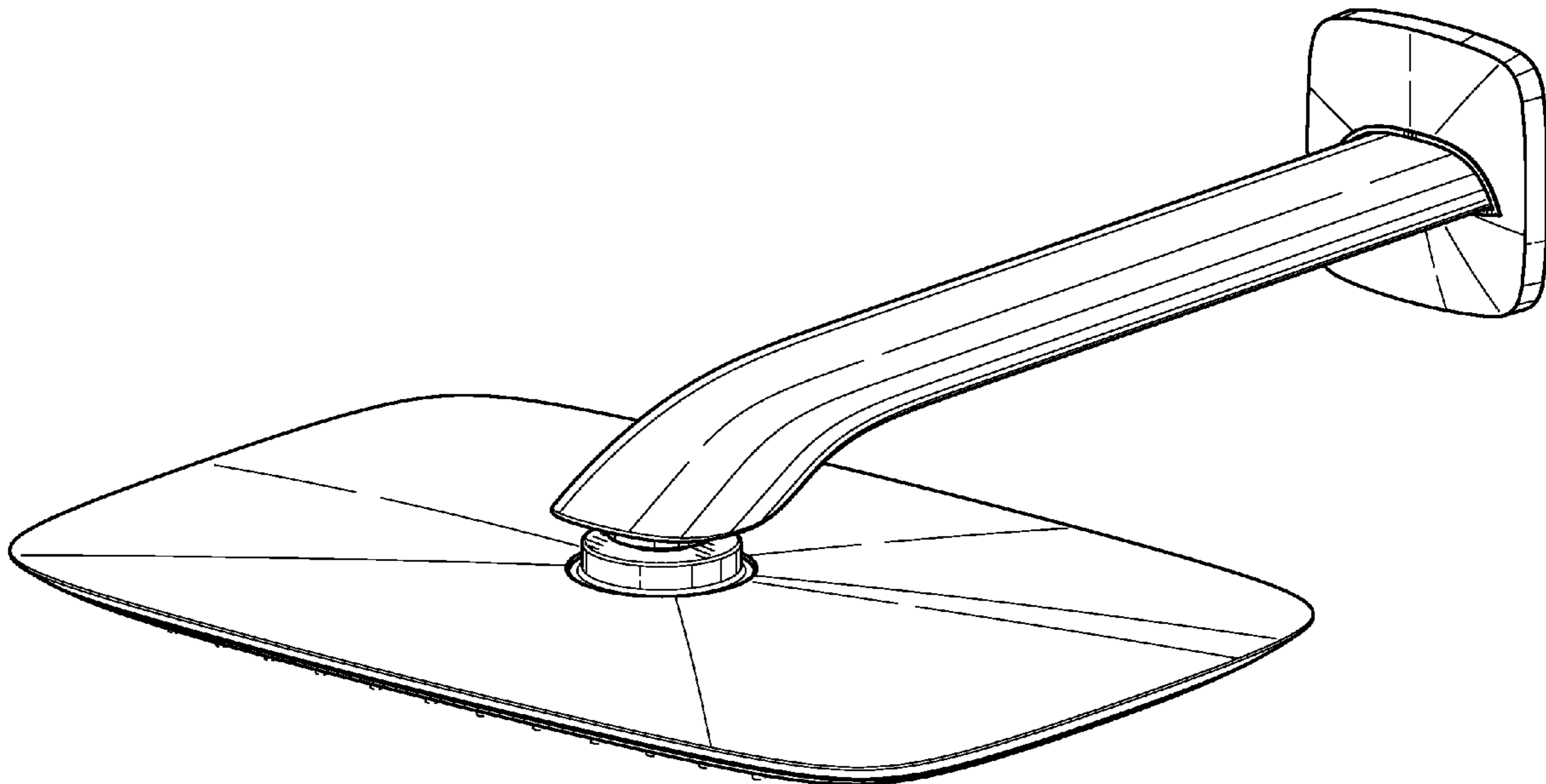

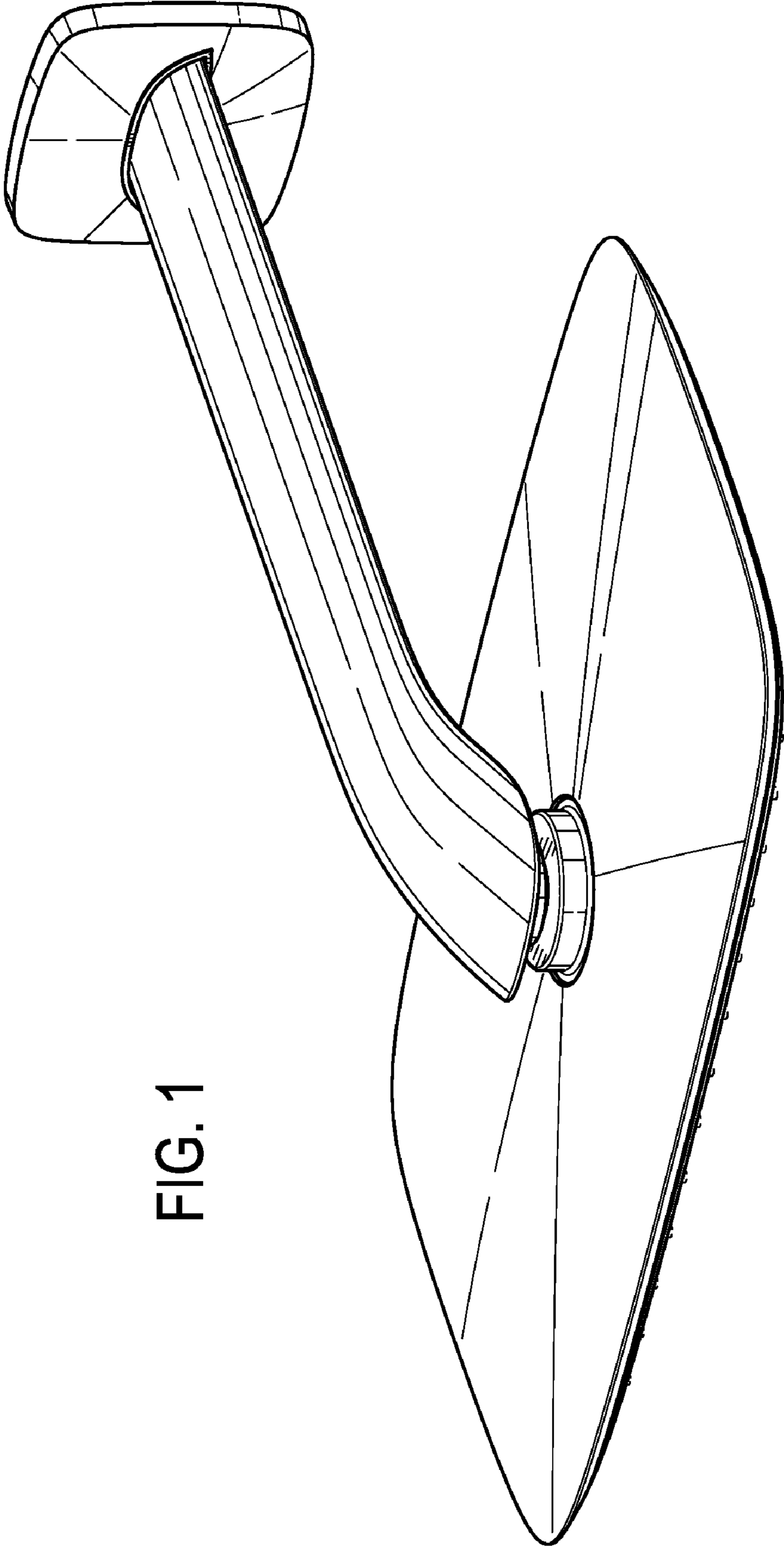

FIG. 1

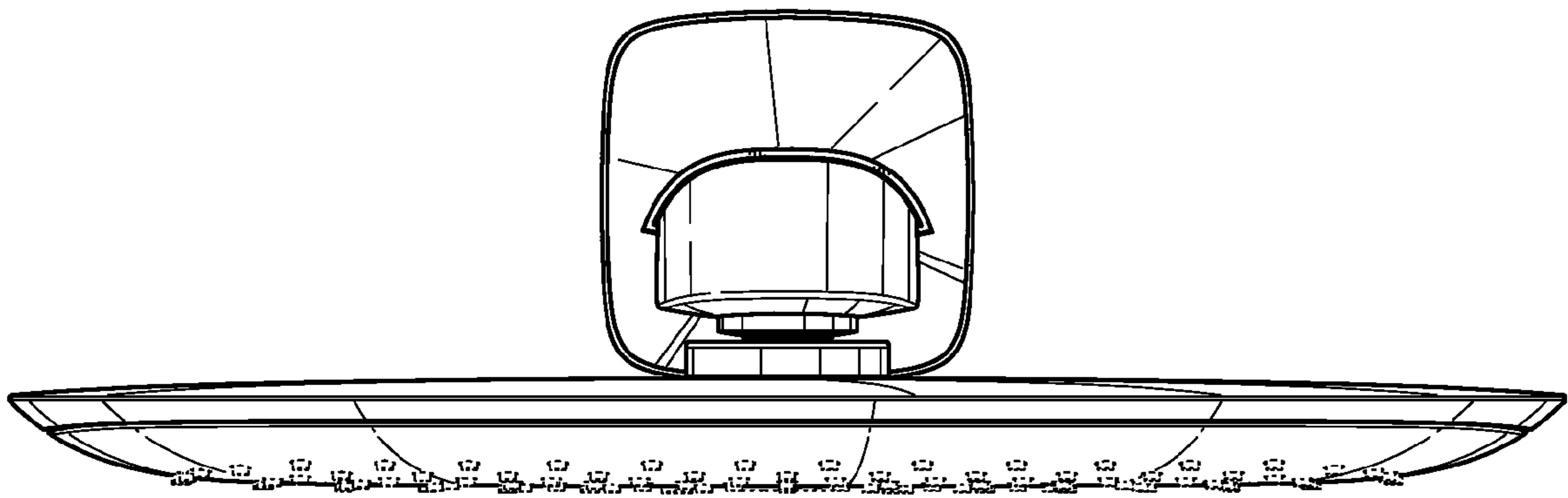

FIG. 2

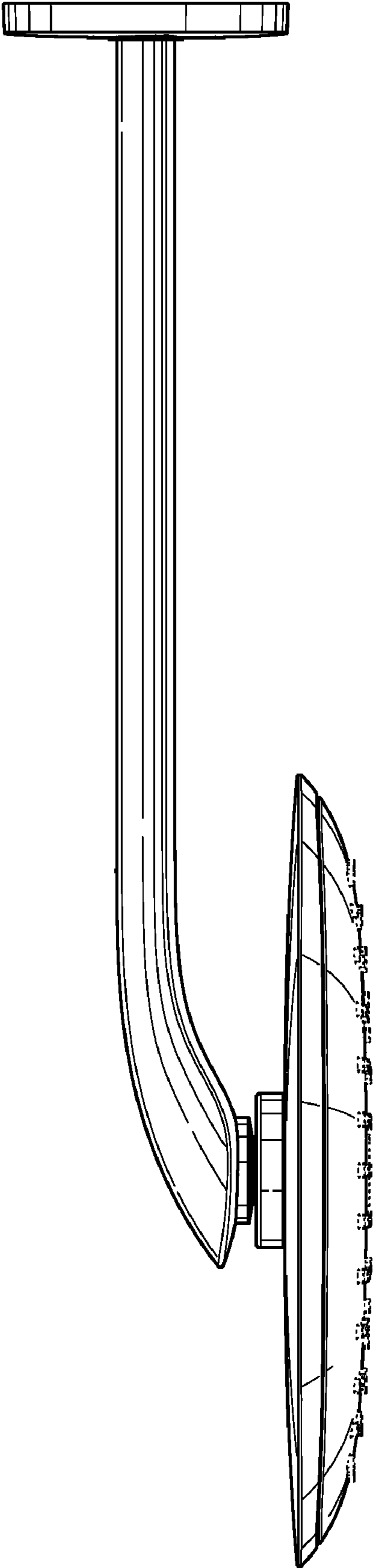
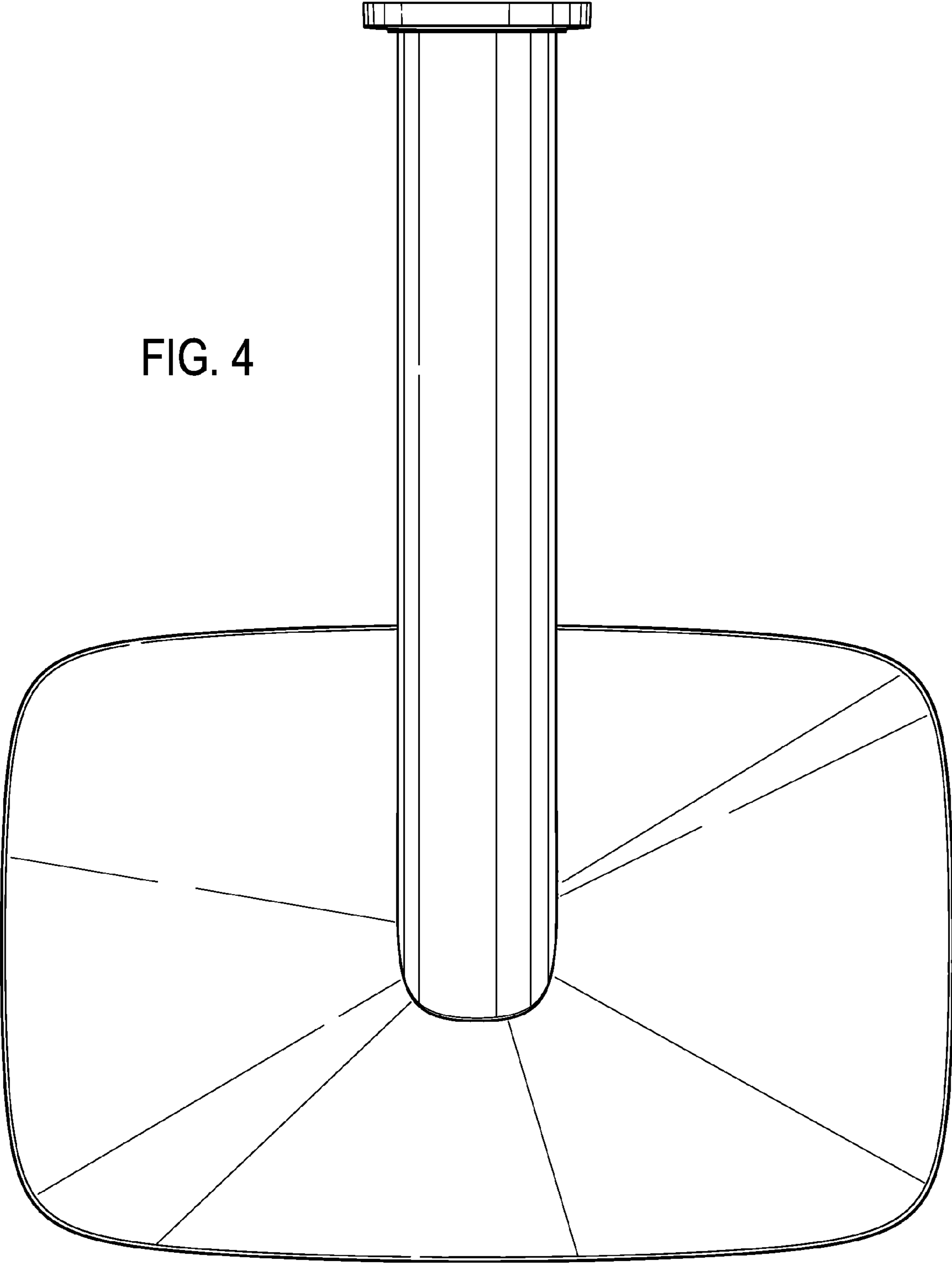

FIG. 3

FIG. 4



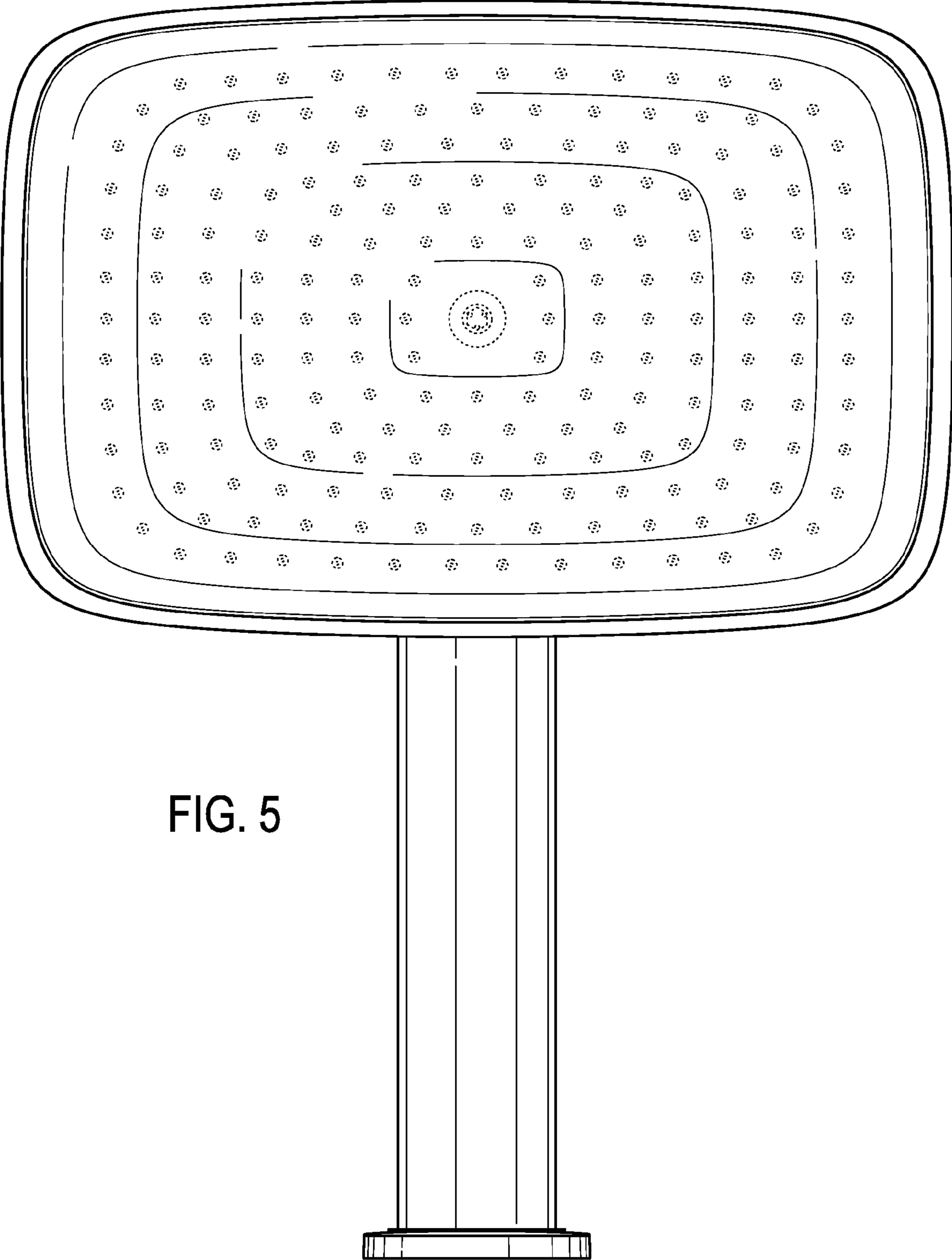

FIG. 5