



US00D611531S

(12) **United States Design Patent**  
**Hatasa et al.**

(10) **Patent No.:** **US D611,531 S**  
(45) **Date of Patent:** **\*\* Mar. 9, 2010**

(54) **INK TANK FOR PRINTER**

(75) Inventors: **Nobuyuki Hatasa**, Kawasaki (JP);  
**Tatsuo Nanjo**, Kawasaki (JP); **Masaaki**  
**Ishibashi**, Hino (JP); **Yasunori**  
**Senshiki**, Tachikawa (JP)

(73) Assignee: **Canon Kabushiki Kaisha**, Tokyo (JP)

(\*\*) Term: **14 Years**

(21) Appl. No.: **29/320,228**

(22) Filed: **Jun. 24, 2008**

(30) **Foreign Application Priority Data**

Dec. 26, 2007 (JP) ..... 2007-035551

(51) **LOC (9) Cl.** ..... **18-02**

(52) **U.S. Cl.** ..... **D18/56**

(58) **Field of Classification Search** ..... D18/14,  
D18/18, 43, 50, 56-59, 99; 347/29, 30, 32,  
347/33, 50, 62, 86-87; D9/417, 521, 533,  
D9/569, 573

See application file for complete search history.

(56) **References Cited**

**U.S. PATENT DOCUMENTS**

4,990,964 A \* 2/1991 Kraehn ..... 399/261  
D326,228 S \* 5/1992 Stratford et al. .... D9/521  
D350,070 S \* 8/1994 Ophardt ..... D9/521  
D368,275 S \* 3/1996 Sakurai et al. .... D18/56  
D417,233 S \* 11/1999 Sabonis ..... D18/56  
D424,611 S \* 5/2000 Gasvoda et al. .... D18/56  
D439,925 S \* 4/2001 Santhanam et al. .... D18/56

D451,394 S \* 12/2001 Studer ..... D9/521  
D454,364 S \* 3/2002 Seino et al. .... D18/56  
D460,480 S \* 7/2002 Yamada et al. .... D18/56  
D472,918 S \* 4/2003 Ueno et al. .... D18/56  
D501,504 S \* 2/2005 Yamada et al. .... D18/56  
D524,367 S \* 7/2006 Wakayama et al. .... D18/56  
D540,377 S 4/2007 Hatasa et al. .... D18/56

\* cited by examiner

*Primary Examiner*—T. Chase Nelson  
*Assistant Examiner*—Susan E Krakower

(74) *Attorney, Agent, or Firm*—Fitzpatrick, Cella, Harper & Scinto

(57) **CLAIM**

The ornamental design for an ink tank for printer, as shown and described.

**DESCRIPTION**

FIG. 1 is the front view of an ink tank for printer showing our new design;

FIG. 2 is a rear view thereof;

FIG. 3 is a top plan view thereof;

FIG. 4 is a bottom plan view thereof;

FIG. 5 is a left side view thereof;

FIG. 6 is a right side view thereof; and,

FIG. 7 is a trimetric view thereof.

The broken line showing of round interior elements in FIGS. 1, 2, and 4 is for purposes of illustrating environmental elements and form no part of the claimed design.

**1 Claim, 6 Drawing Sheets**

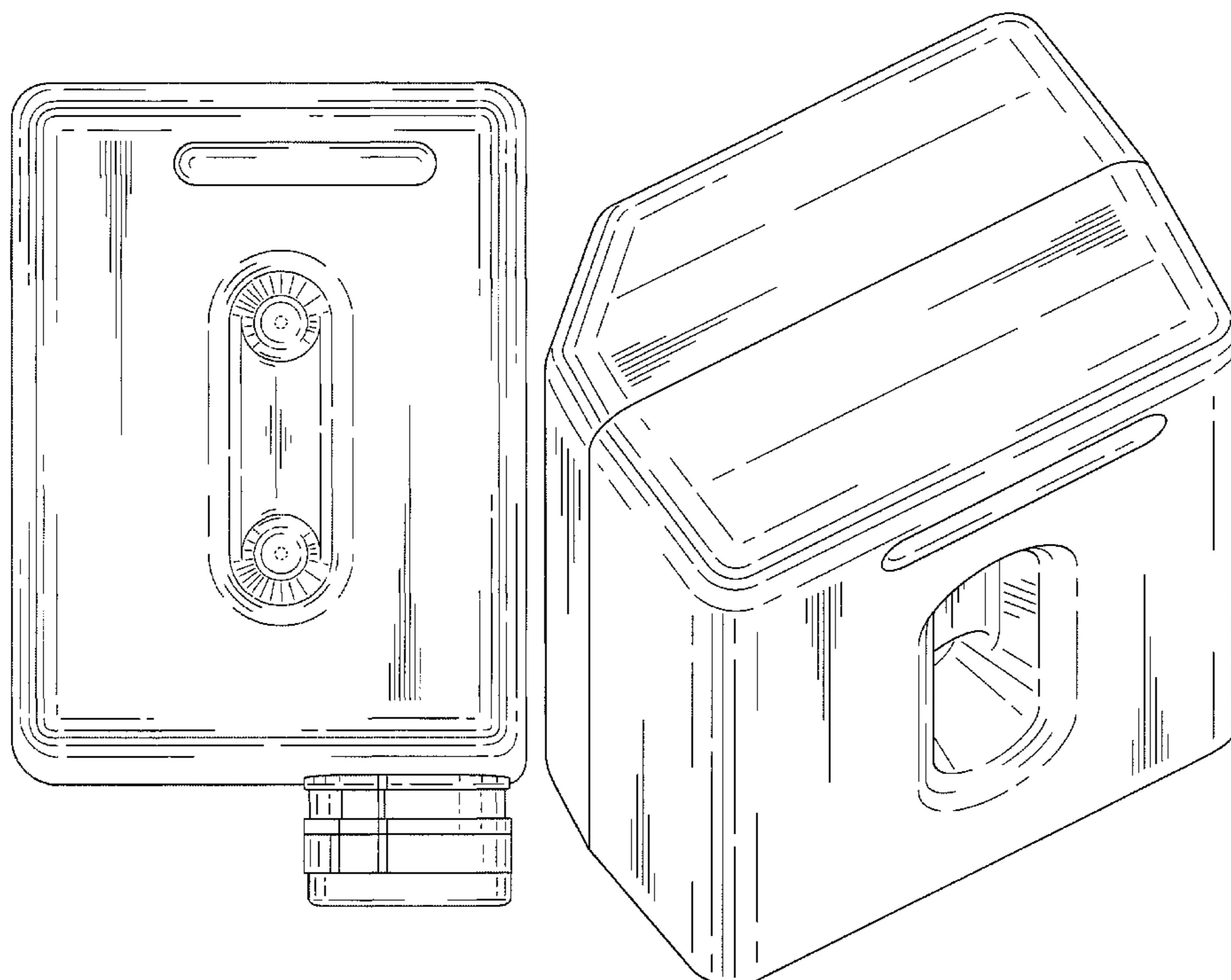

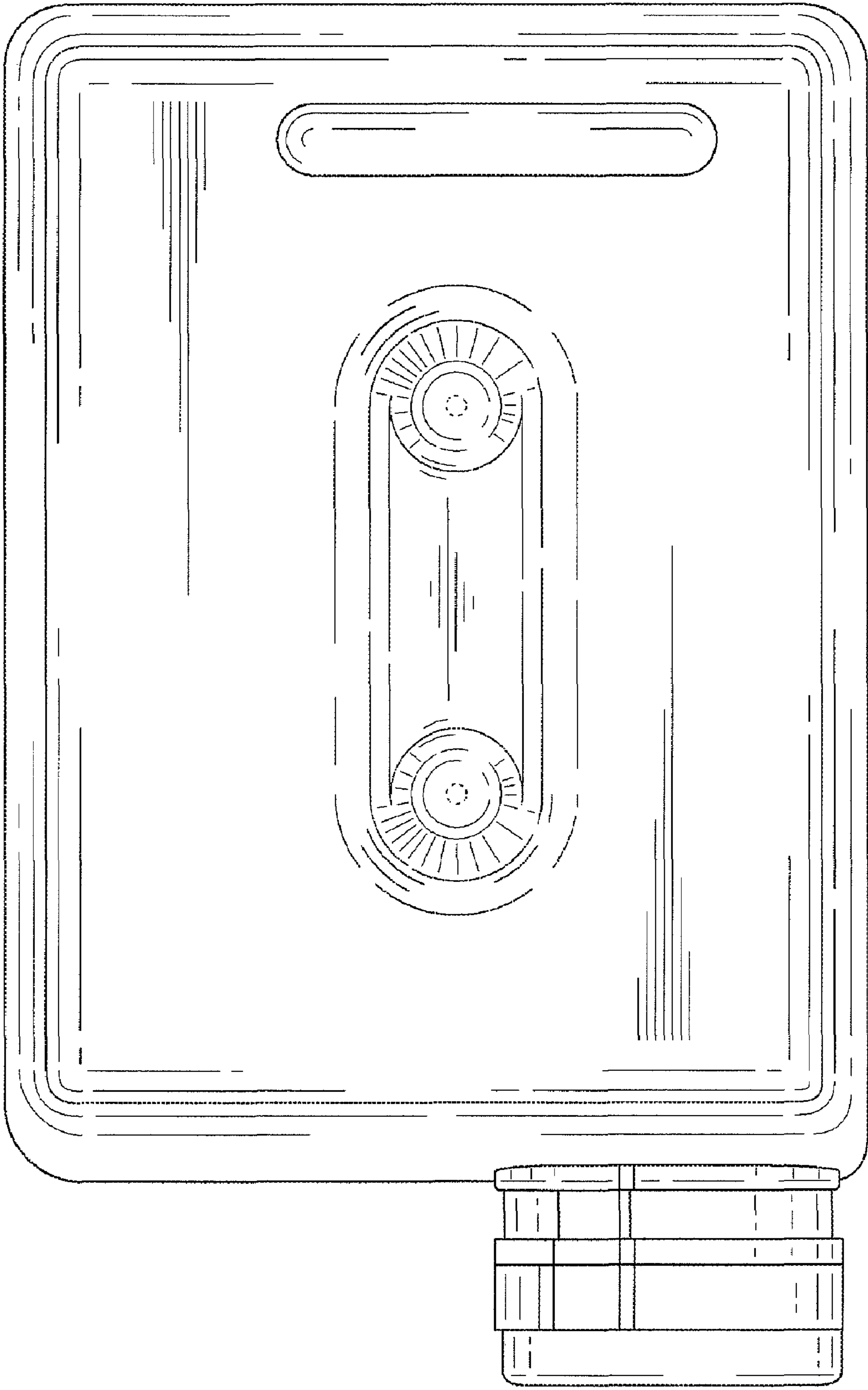
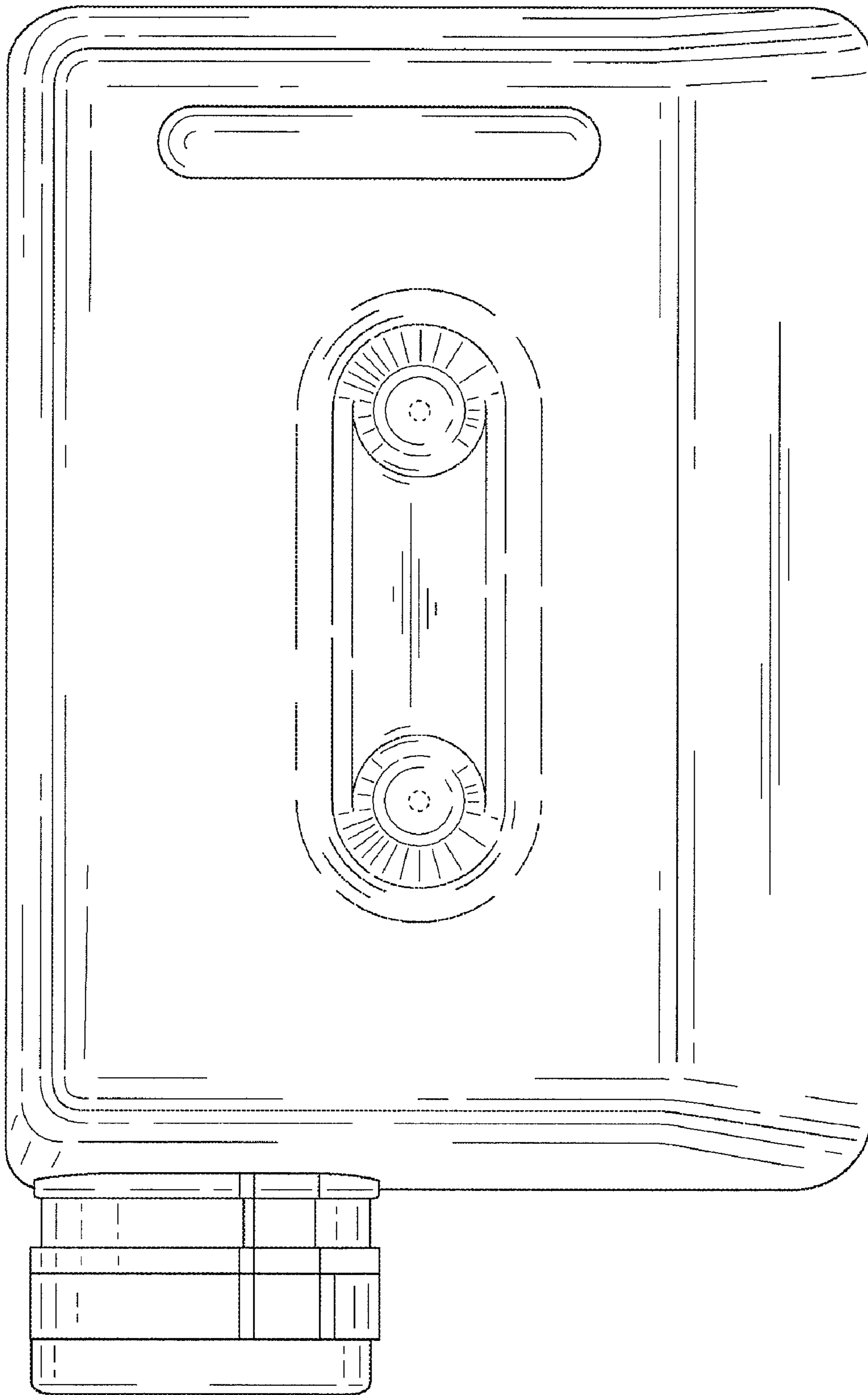

FIG. 1



*FIG. 2*

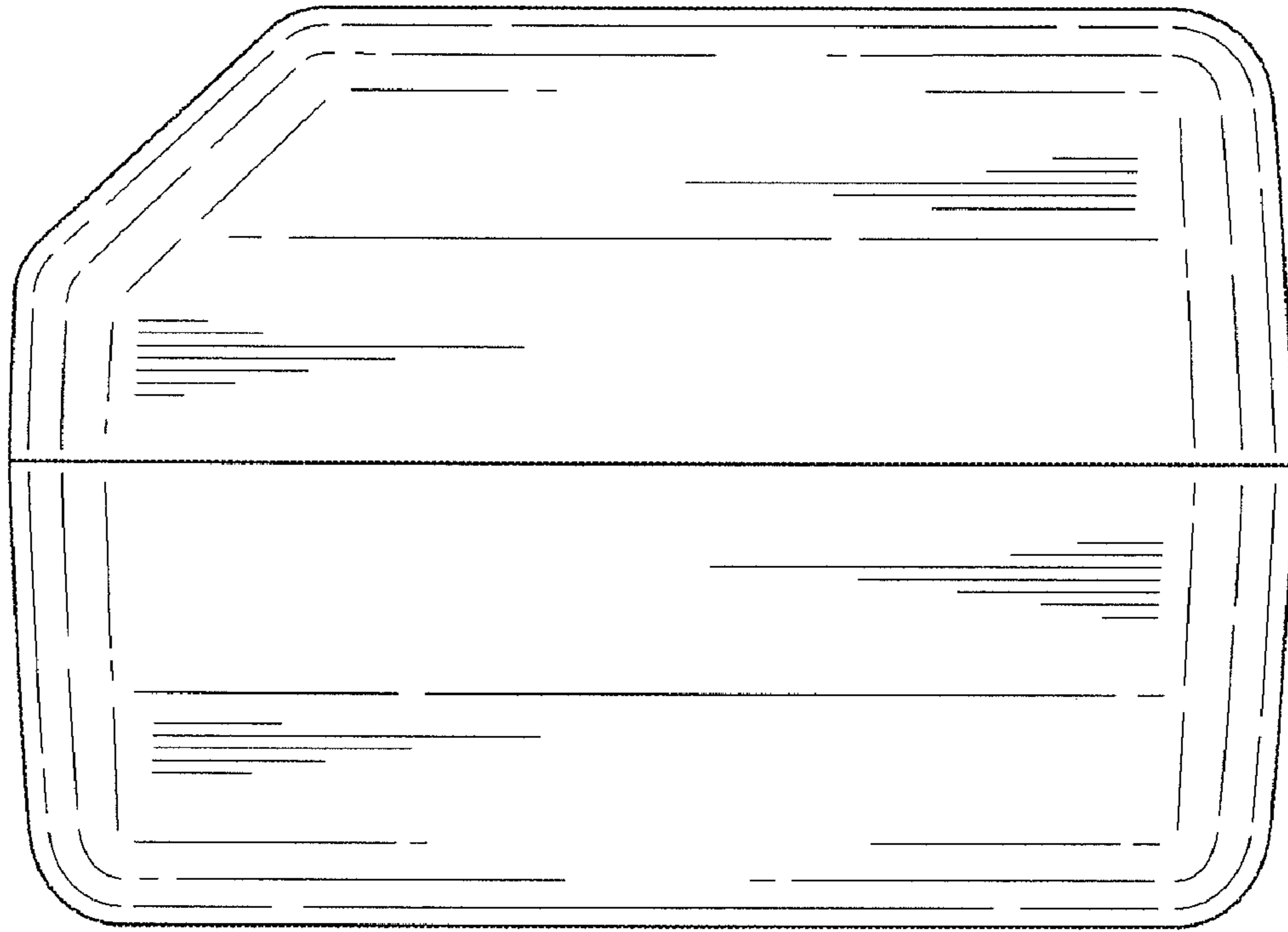

FIG. 3

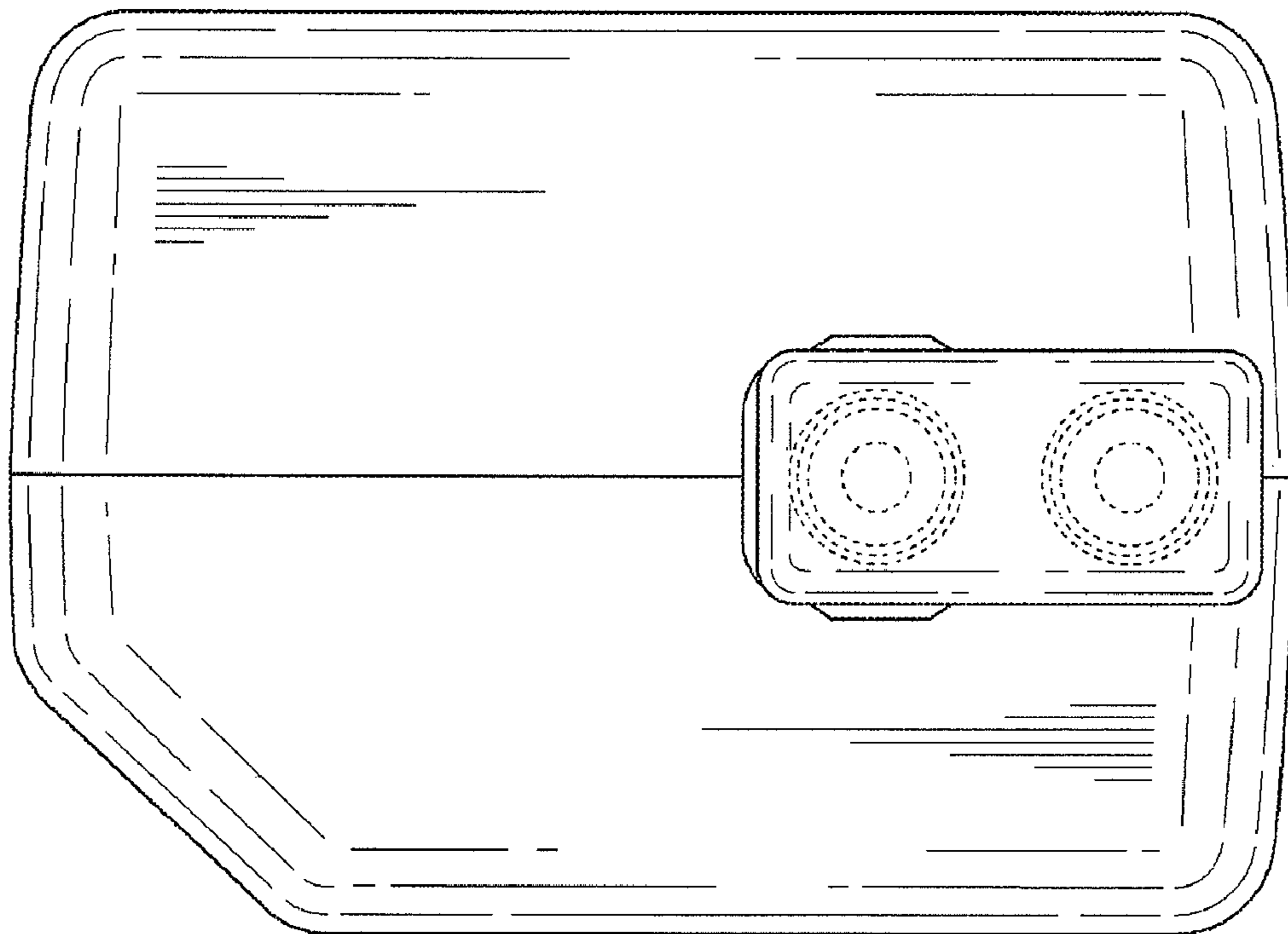

FIG. 4

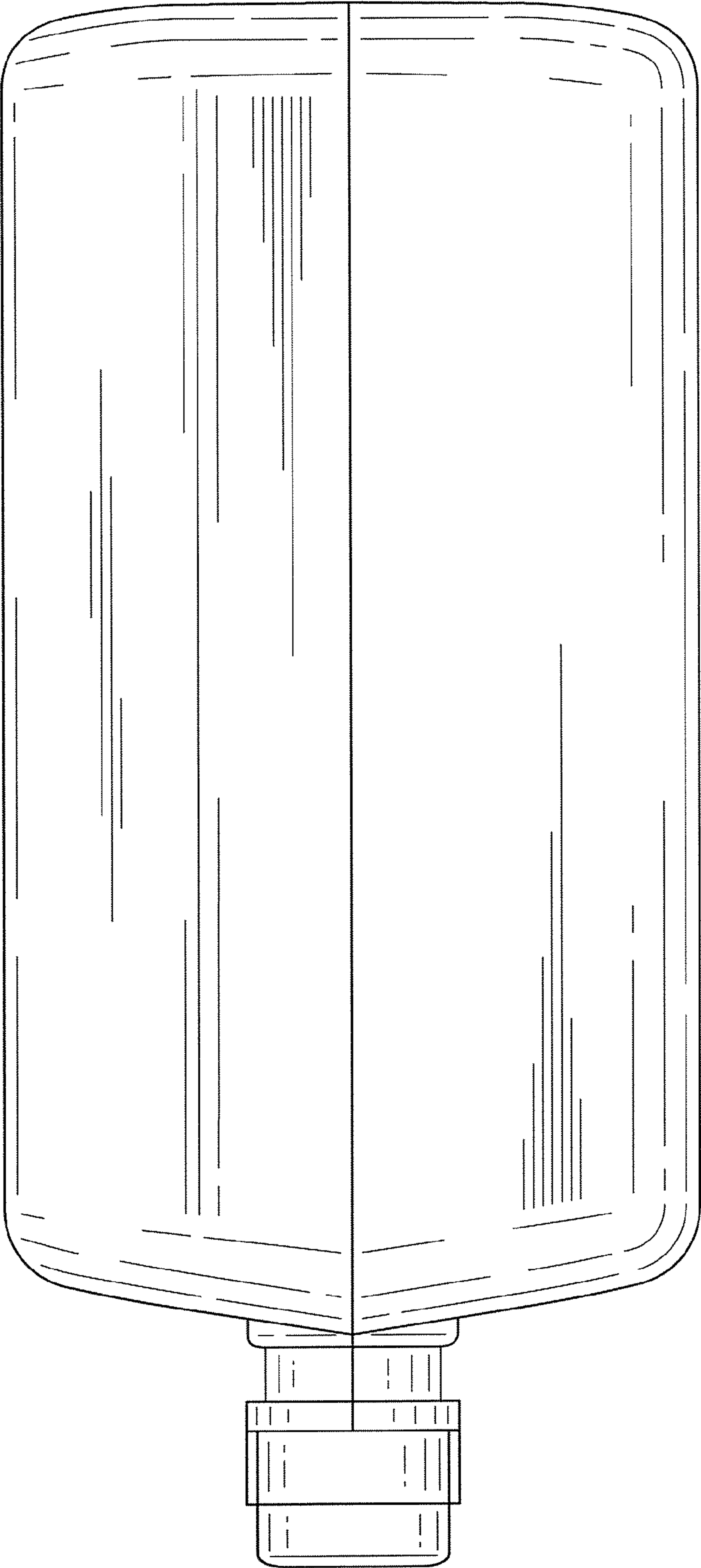
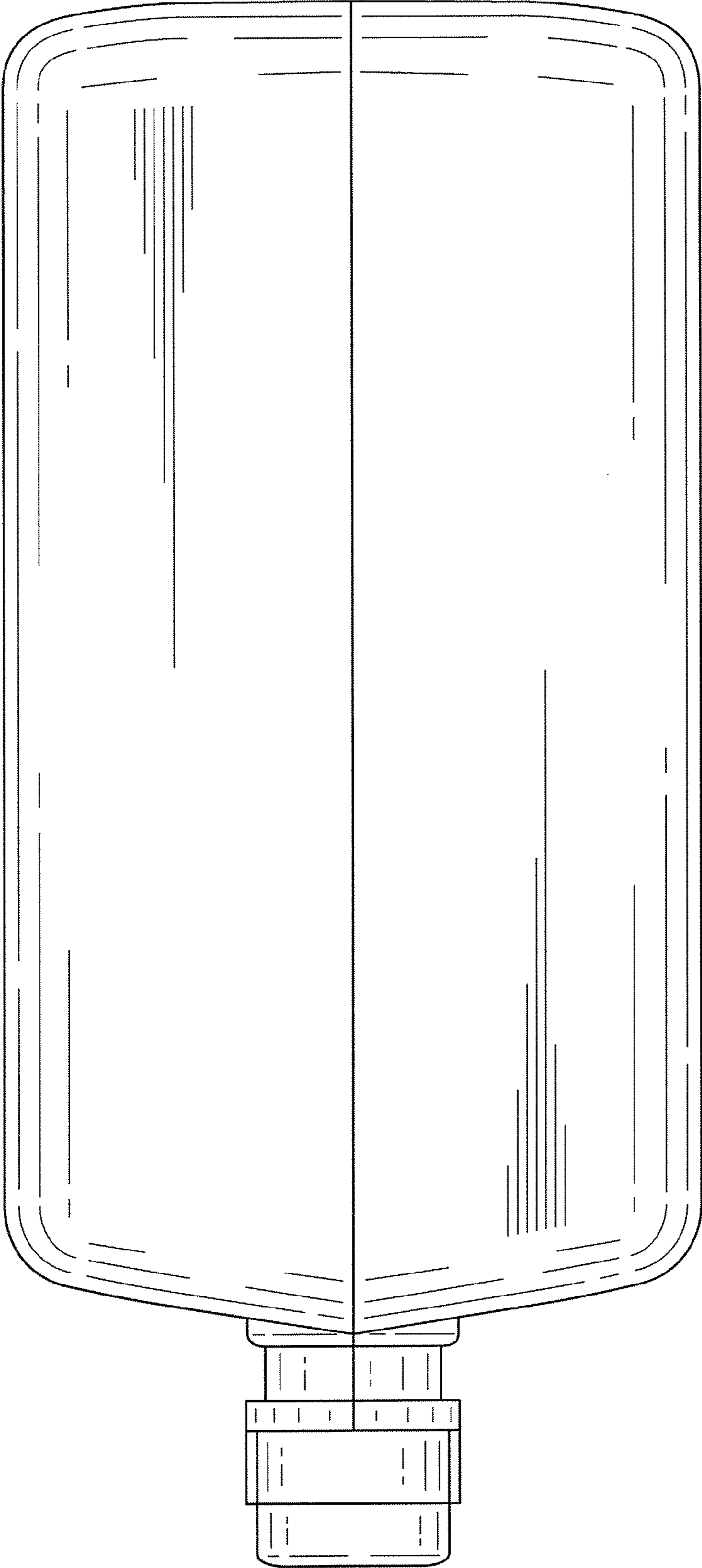
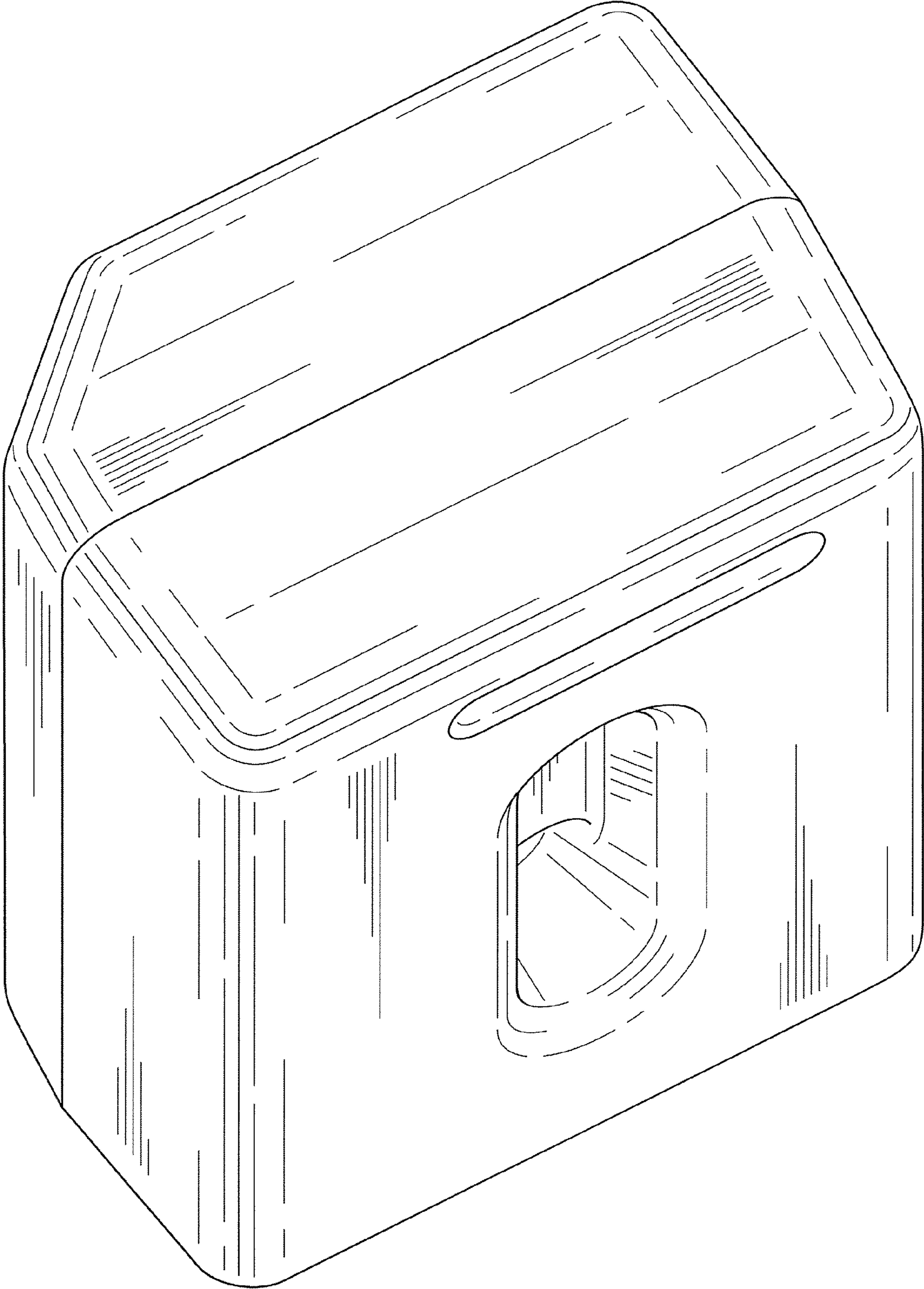

FIG. 5



*FIG. 6*



**FIG. 7**