



US00D611519S

(12) **United States Design Patent**
Kwon et al.

(10) **Patent No.:** **US D611,519 S**
(45) **Date of Patent:** **** Mar. 9, 2010**

(54) **DIGITAL CAMERA**

(75) Inventors: **Ki-jin Kwon**, Suwon-si (KR); **Seung-ho Jang**, Suwon-si (KR)

(73) Assignee: **Samsung Digital Imaging Co., Ltd.**, Suwon-si (KR)

(**) Term: **14 Years**

(21) Appl. No.: **29/315,561**

(22) Filed: **Jul. 6, 2009**

(30) **Foreign Application Priority Data**

May 14, 2009 (KR) 30-2009-0020756

(51) **LOC (9) Cl.** **16-05**

(52) **U.S. Cl.** **D16/219**

(58) **Field of Classification Search** D16/200-204,
D16/208, 218, 219; 348/373-376; 358/909.1;
396/535-541

See application file for complete search history.

(56) **References Cited**

U.S. PATENT DOCUMENTS

6,788,894 B2 * 9/2004 Suzuki et al. 348/373
D501,497 S * 2/2005 Hayamizu D16/219
D506,490 S * 6/2005 Hayashi D16/219
D522,036 S * 5/2006 Nagayama et al. D16/202

D559,297 S * 1/2008 Nakamura D16/219
D561,228 S * 2/2008 Imai D16/202
D582,462 S * 12/2008 Hayashi D16/219
7,507,041 B2 * 3/2009 Ueda et al. 348/375

* cited by examiner

Primary Examiner—Adir Aronovich

(74) *Attorney, Agent, or Firm*—Drinker Biddle & Realth LLP

(57) **CLAIM**

The ornamental design for a digital camera, as shown and described.

DESCRIPTION

FIG. 1 is a top, front and right side perspective view of a digital camera showing our new design;

FIG. 2 is a front elevational view of the digital camera;

FIG. 3 is a rear elevational view of the digital camera;

FIG. 4 is left side elevational view thereof;

FIG. 5 is right side elevational view thereof;

FIG. 6 is a top plan view of the digital camera; and,

FIG. 7 is a bottom plan view of the digital camera.

The portions of the digital camera in broken lines are shown for illustrative purposes only and form no part of the claimed design.

1 Claim, 4 Drawing Sheets

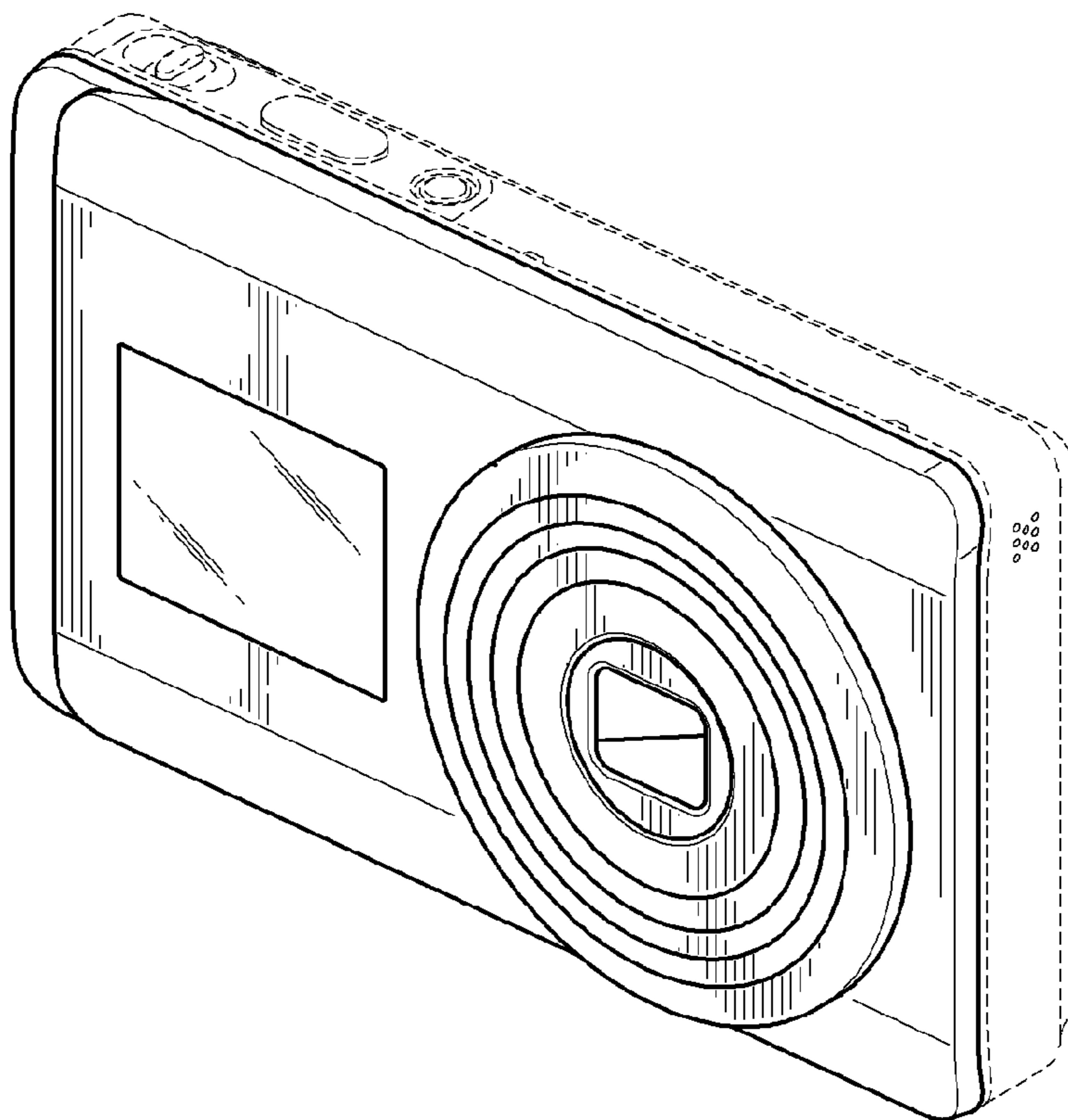

FIG. 1

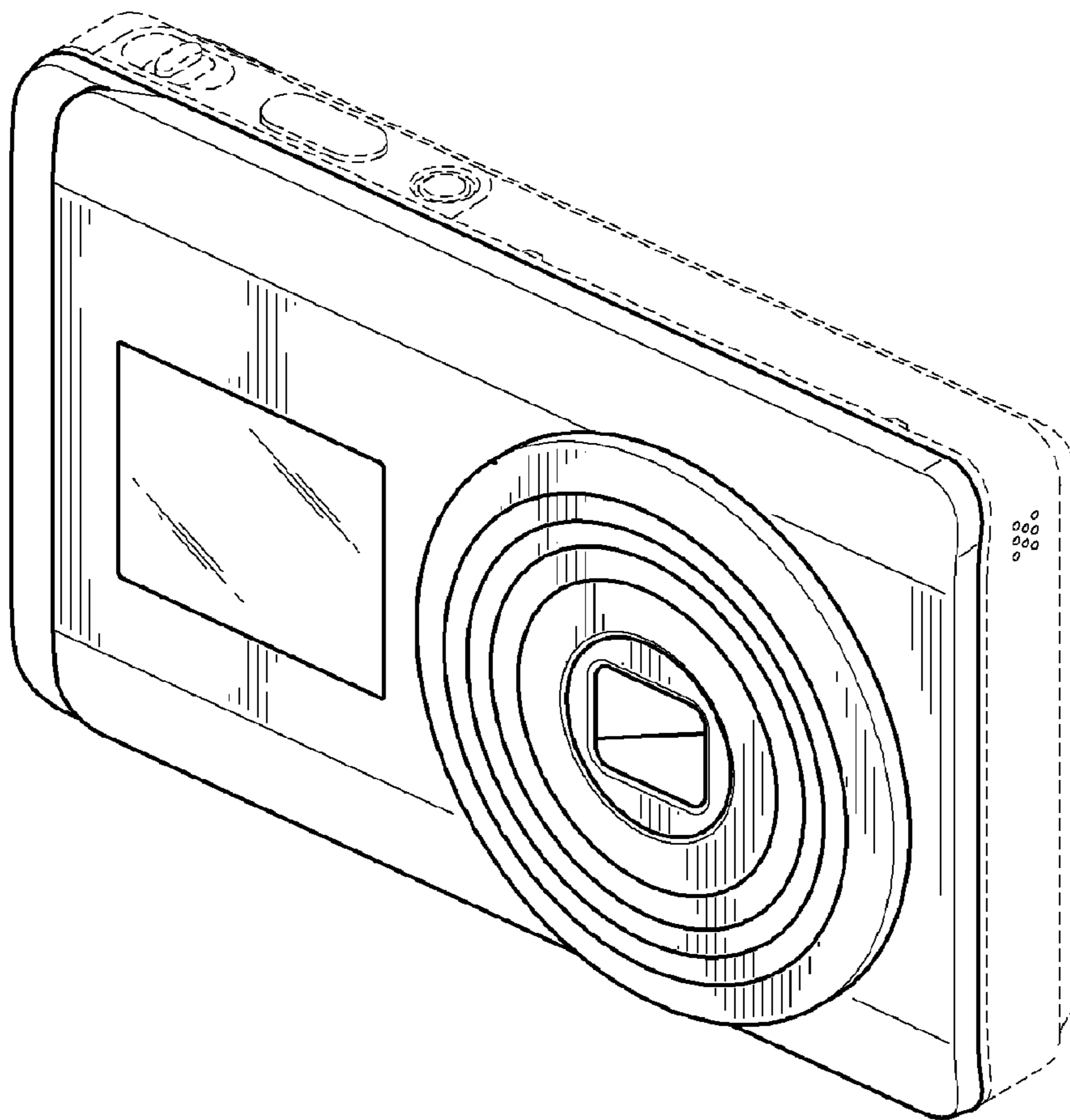

FIG. 2

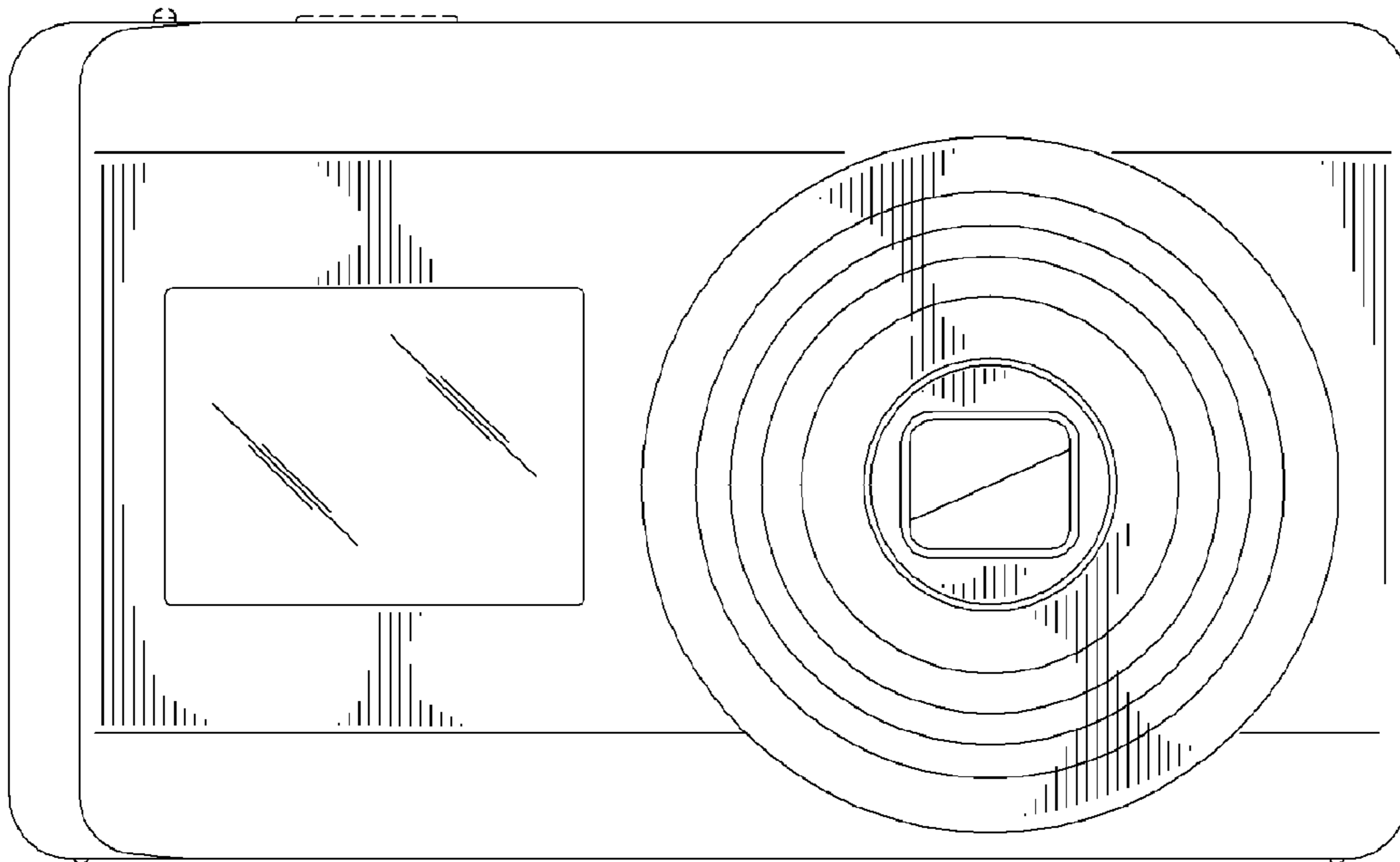

FIG. 3

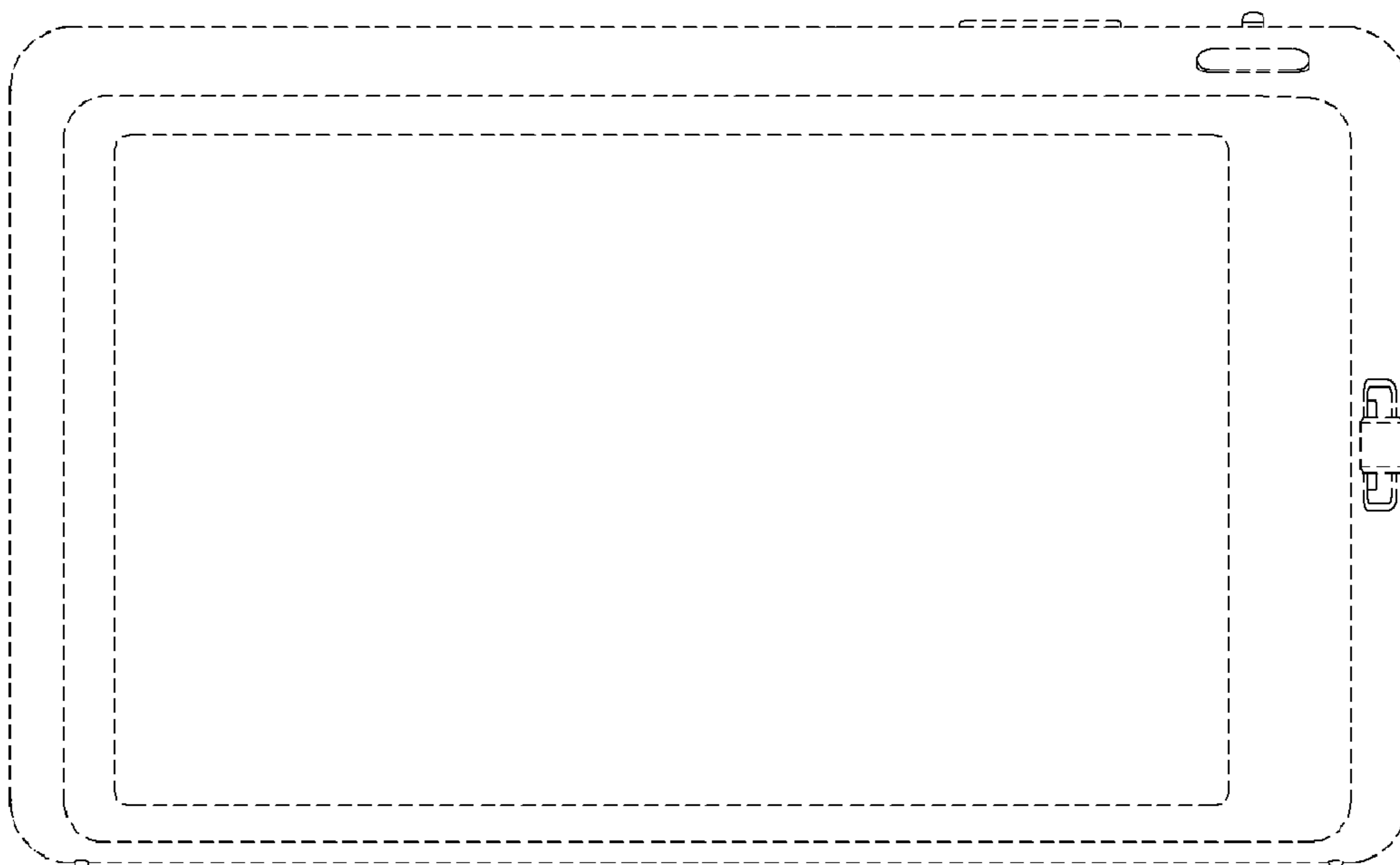

FIG. 4

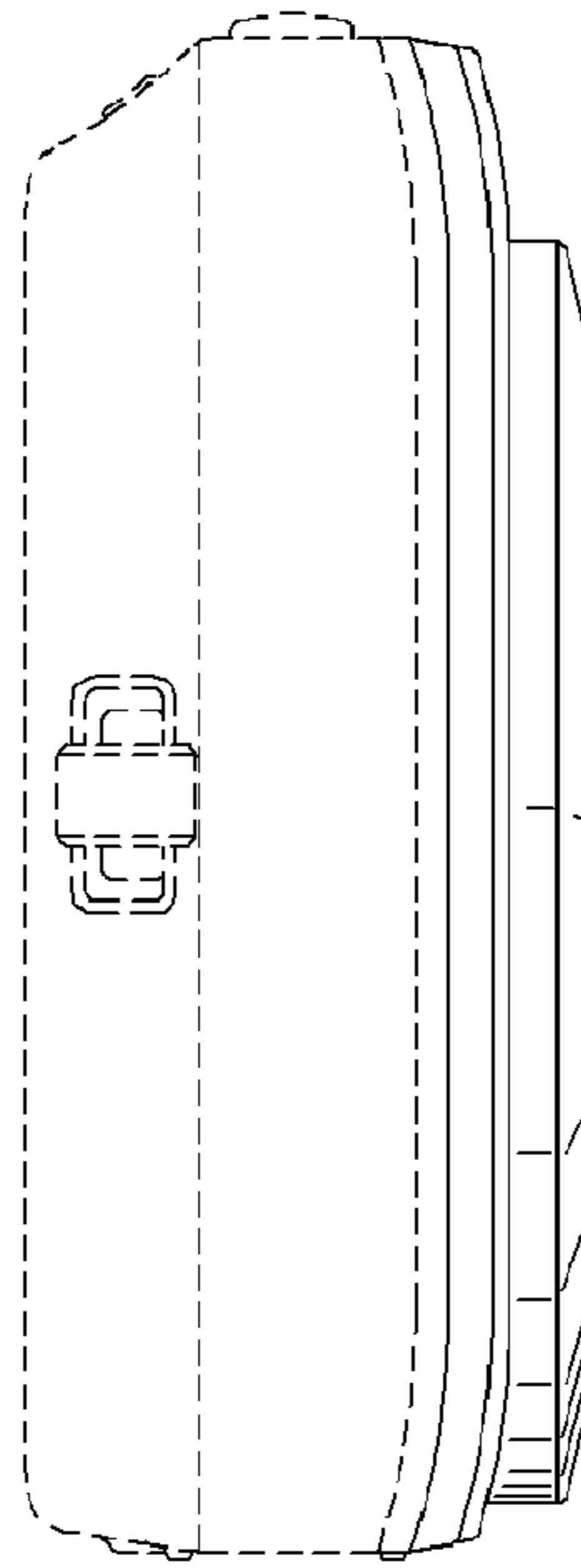

FIG. 5

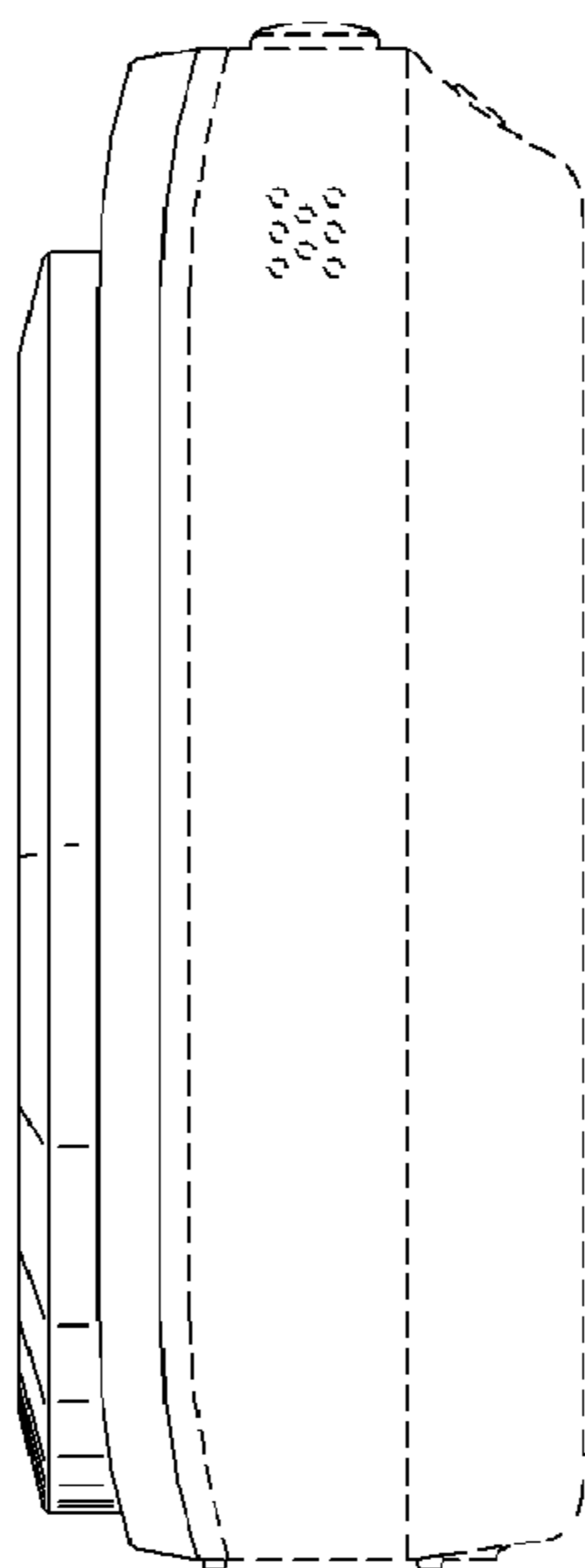

FIG. 6

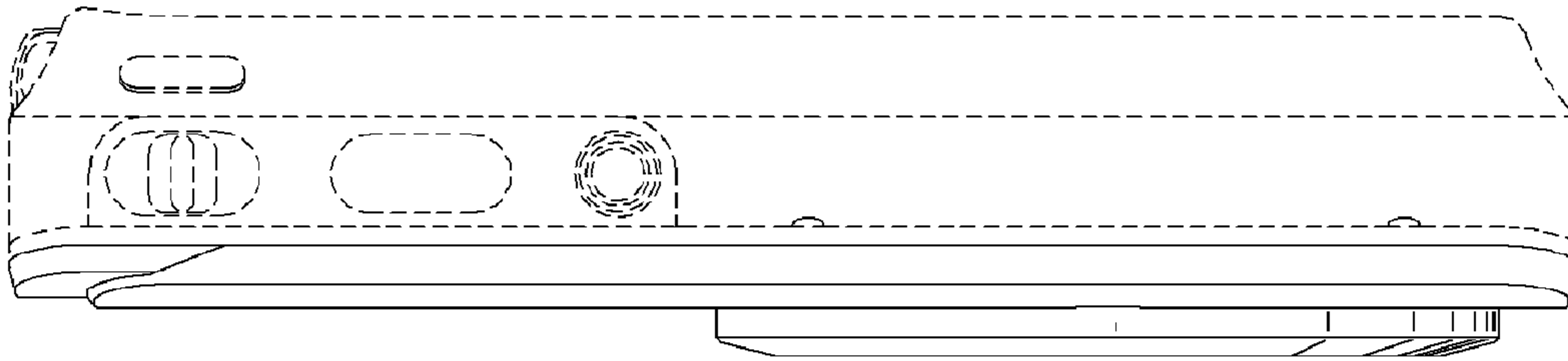

FIG. 7

