



US00D611502S

(12) **United States Design Patent**
Vignau et al.

(10) **Patent No.:** **US D611,502 S**
(45) **Date of Patent:** **** Mar. 9, 2010**

(54) **TILLER FOR AN OUTBOARD ENGINE**

(75) Inventors: **Pierre Vignau**, Sherbrooke (CA);
Christian Lepine, Sherbrooke (CA)

(73) Assignee: **BRP US Inc.**, Sturtevant, MI (US)

(**) Term: **14 Years**

(21) Appl. No.: **29/320,583**

(22) Filed: **Jun. 30, 2008**

(51) **LOC (9) Cl.** **15-01**

(52) **U.S. Cl.** **D15/5**

(58) **Field of Classification Search** D15/4,
D15/5; 114/144 R, 146; 74/480 B, 483 R,
74/491-492, 481, 523, 543; 440/53, 63,
440/84, 86, 87

See application file for complete search history.

(56) **References Cited**

U.S. PATENT DOCUMENTS

1,459,754	A *	6/1923	Smith	206/278
2,196,347	A *	4/1940	Von Meyenburg	172/43
3,599,168	A *	8/1971	Long	439/476.1
D264,084	S *	4/1982	Morgan	D15/4
D276,811	S *	12/1984	Wolfe	D15/4
D295,867	S *	5/1988	Walsh	D15/4
D298,253	S *	10/1988	Erwin et al.	D15/4

D351,583	S *	10/1994	Plennert et al.	D12/317
6,406,343	B2 *	6/2002	Kawai et al.	440/86
6,902,450	B2 *	6/2005	Ohtsuki et al.	440/63
D527,737	S *	9/2006	Iekura	D15/4
D600,425	S *	9/2009	Smiley et al.	D34/35

* cited by examiner

Primary Examiner—Cathron C. Brooks

Assistant Examiner—Maurice Stevens

(74) *Attorney, Agent, or Firm*—Osler, Hoskin & Harcourt LLP

(57) **CLAIM**

The ornamental design for a tiller for an outboard engine, as shown and described.

DESCRIPTION

FIG. 1 is a front right perspective view showing a tiller for an outboard engine according to our design;

FIG. 2 is a right side elevation view thereof;

FIG. 3 is a left side elevation view thereof;

FIG. 4 is a top plan view thereof;

FIG. 5 is a bottom plan view thereof;

FIG. 6 is a front elevation view thereof; and,

FIG. 7 is a rear elevation view thereof.

1 Claim, 6 Drawing Sheets

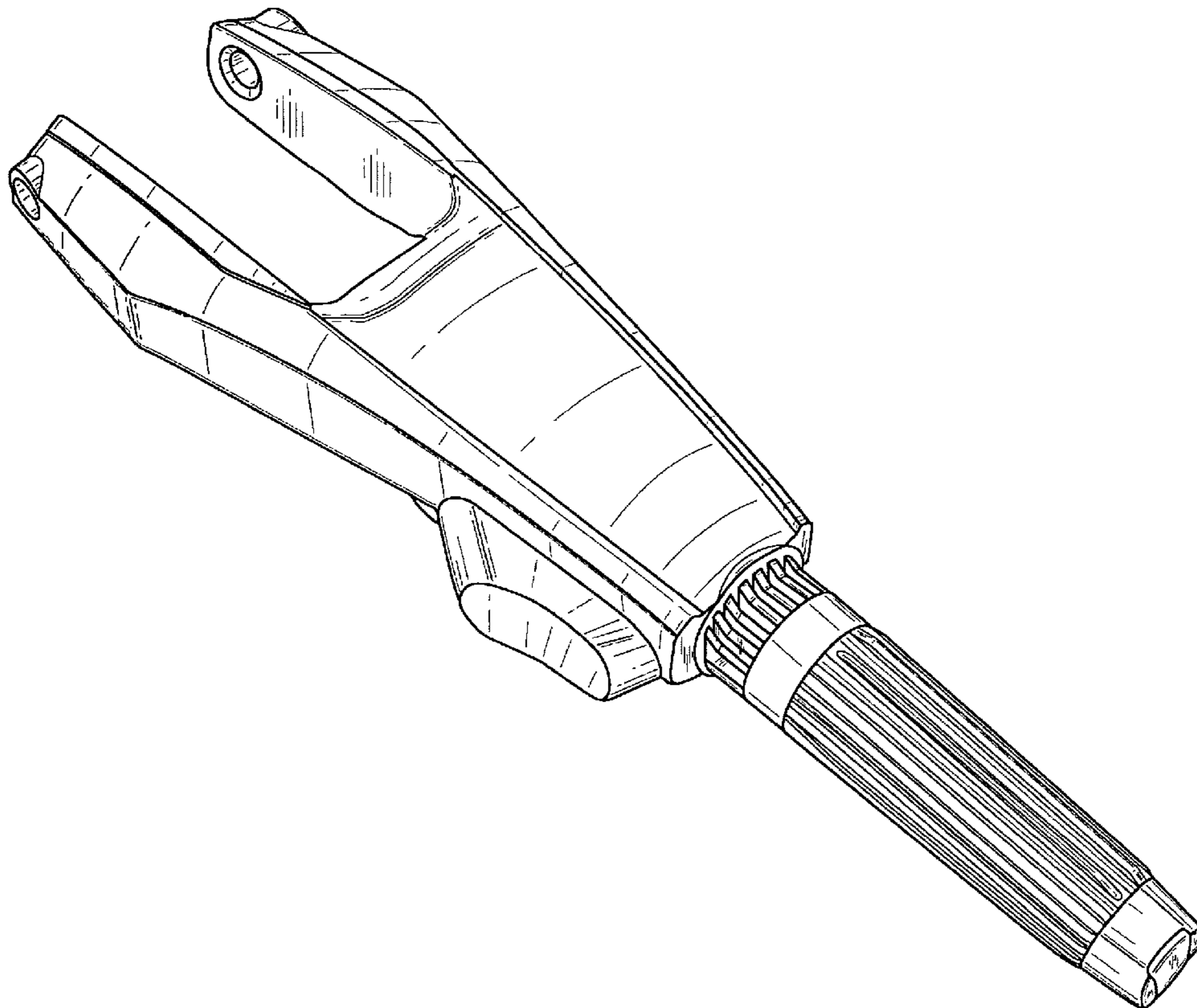

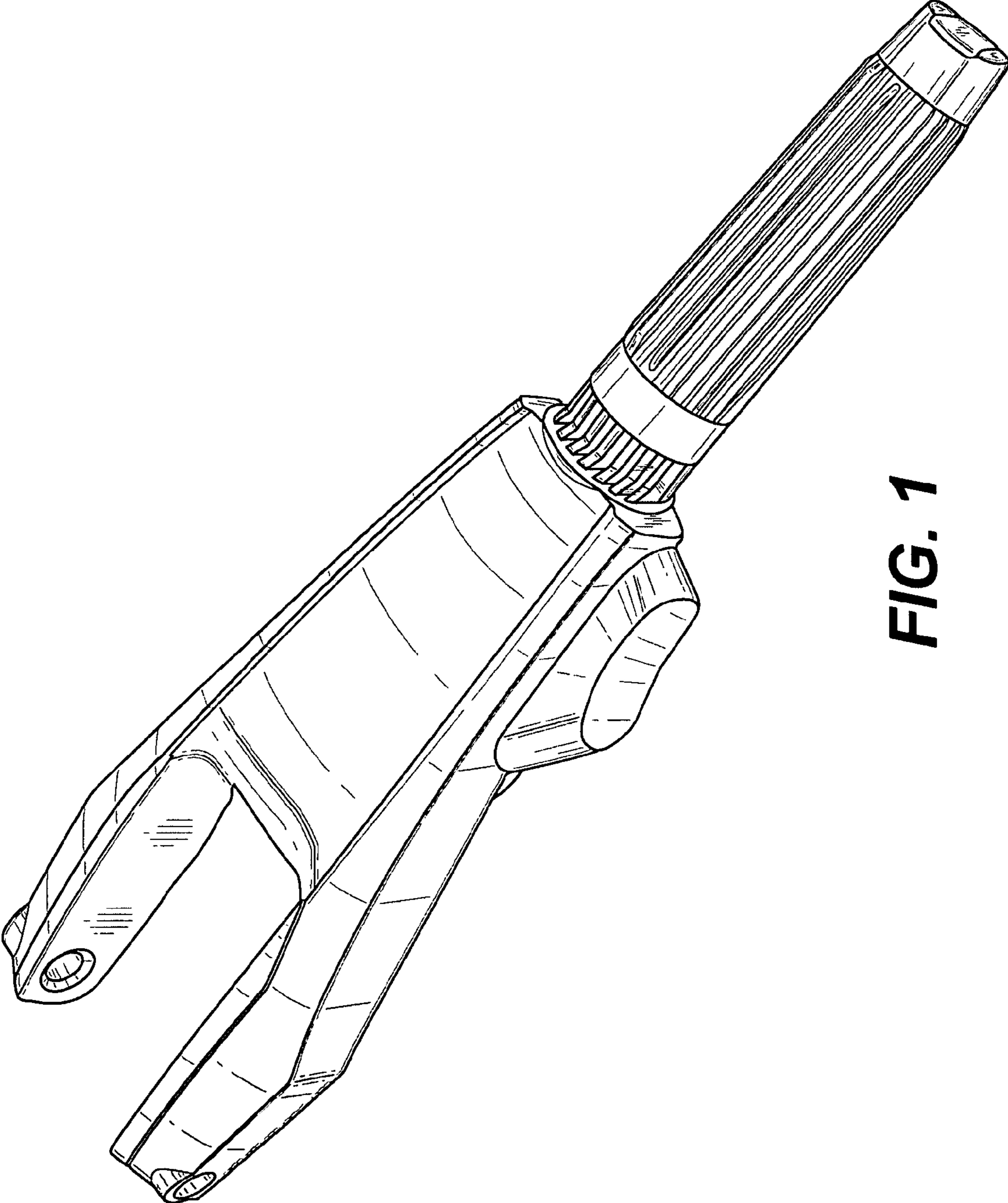

FIG. 1

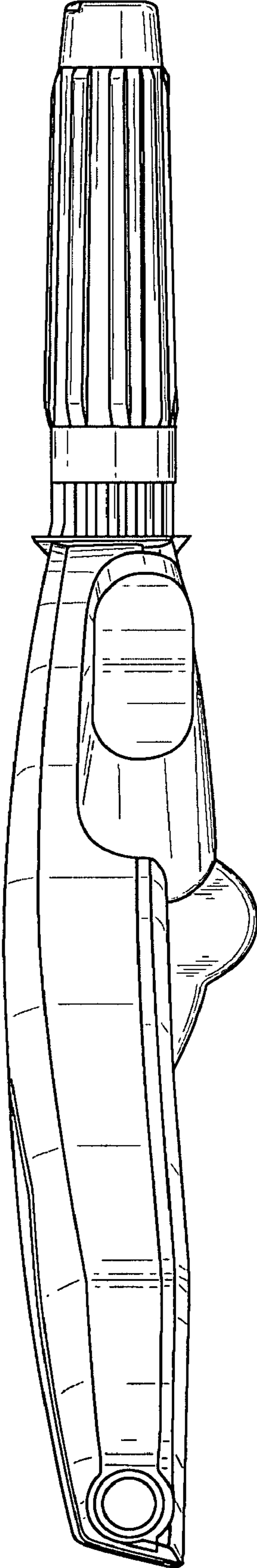

FIG. 2

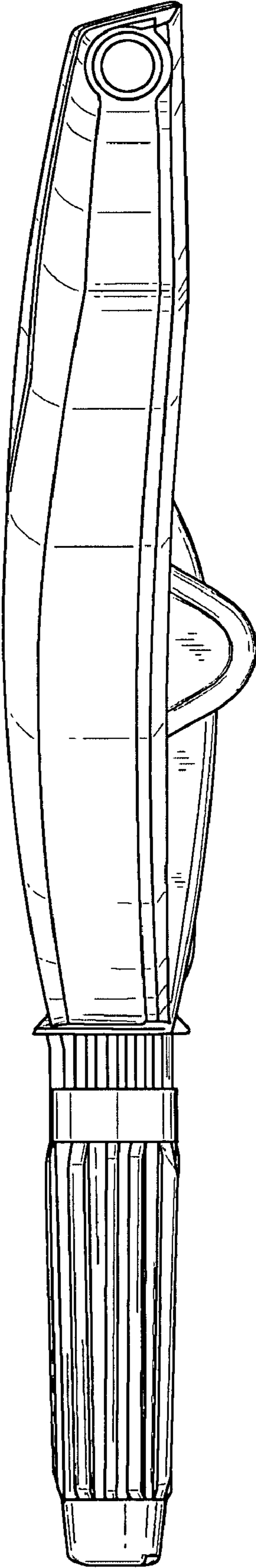

FIG. 3

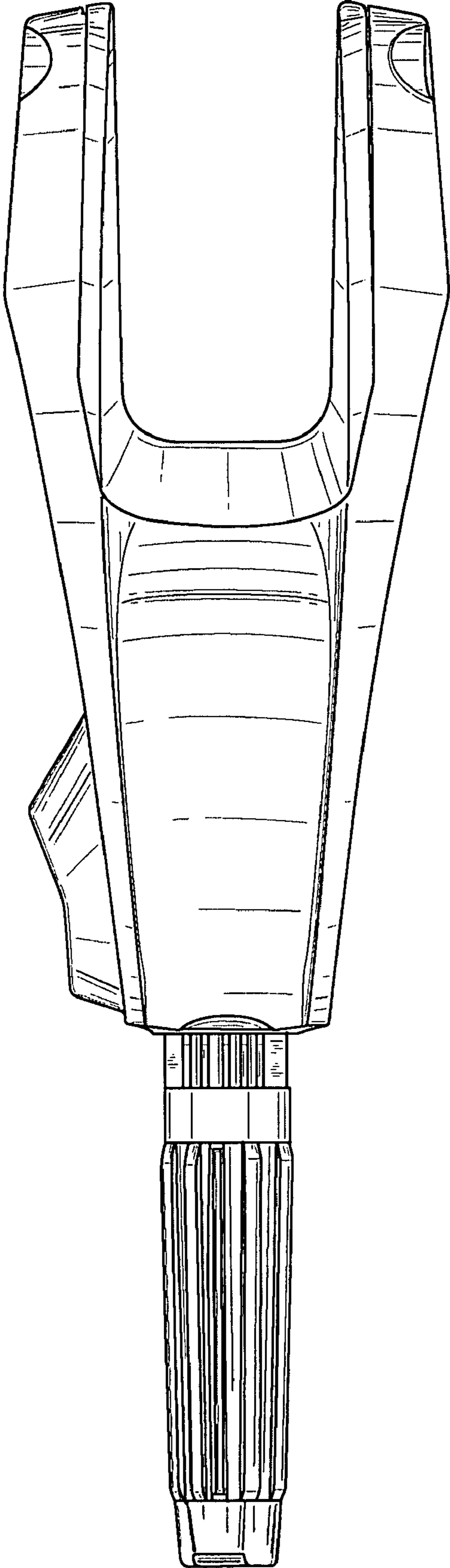

FIG. 4

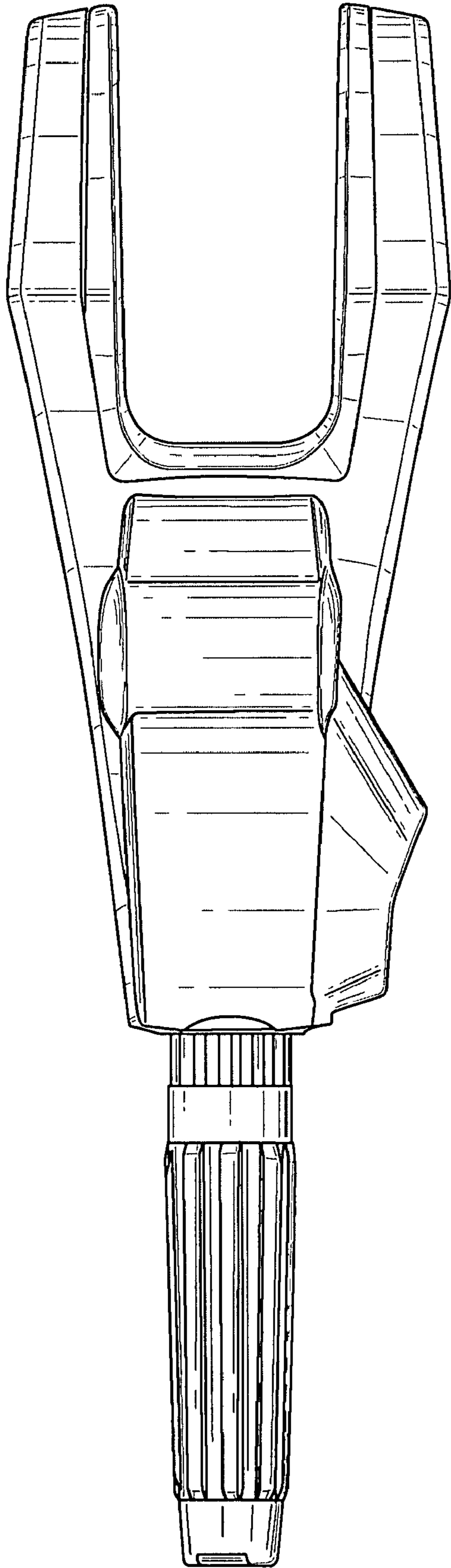

FIG. 5

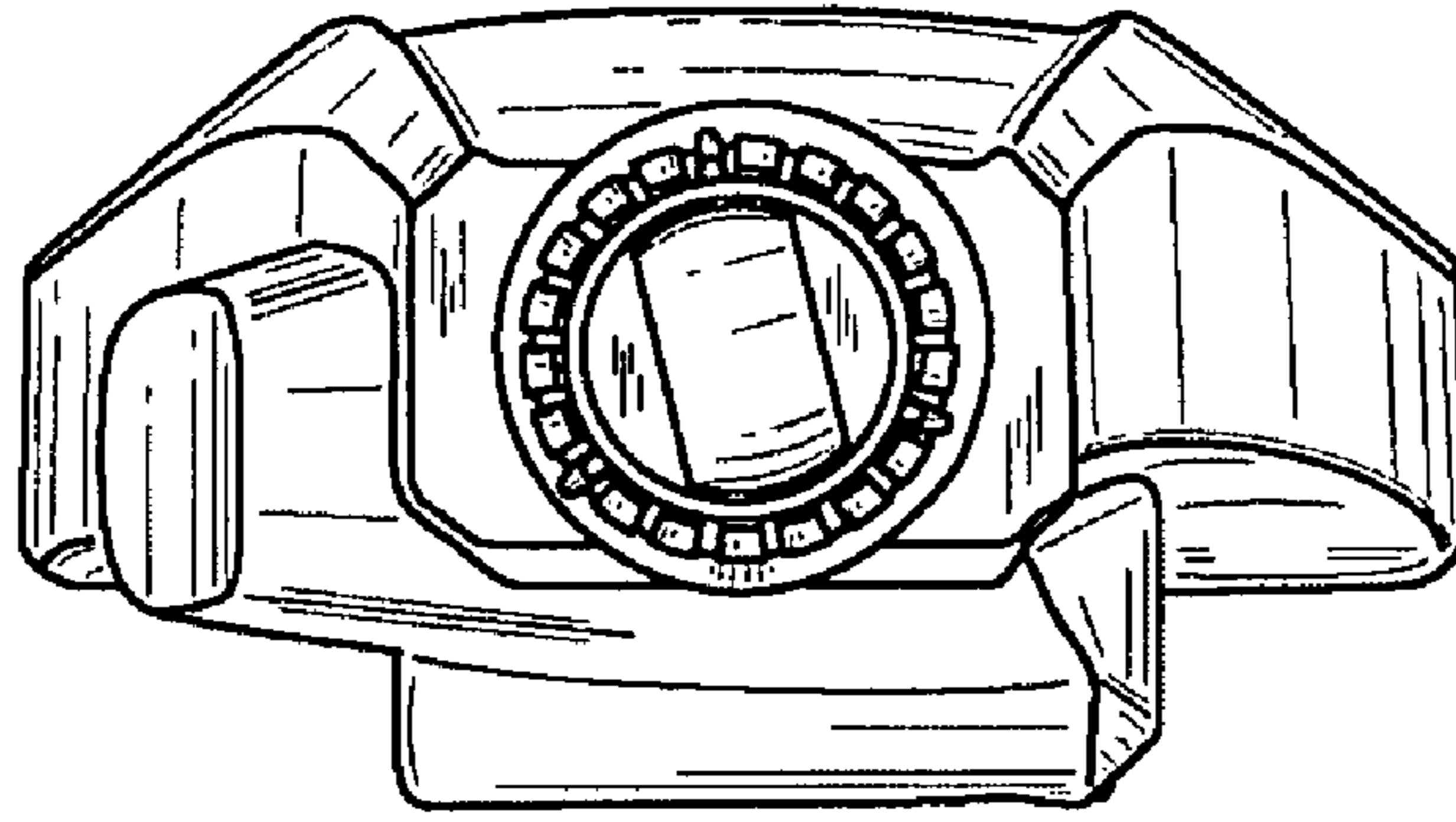

FIG. 6

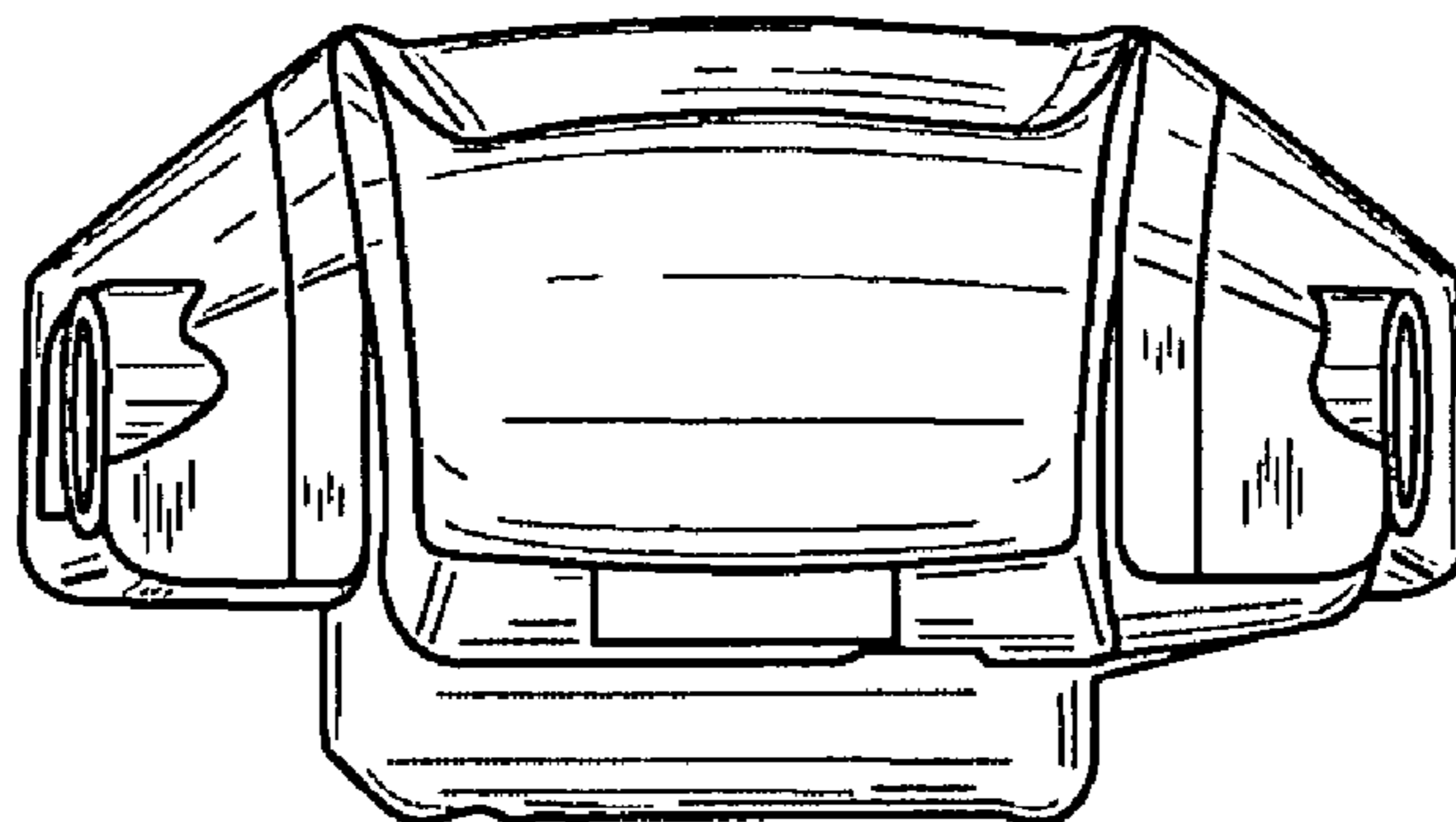

FIG. 7