



US00D611403S

(12) **United States Design Patent**
Kuwano

(10) **Patent No.:** **US D611,403 S**
(45) **Date of Patent:** **** Mar. 9, 2010**

- (54) **TIRE**
- (75) Inventor: **Shingo Kuwano**, Osaka (JP)
- (73) Assignee: **Toyo Tire & Rubber Co., Ltd.**, Osaka (JP)
- (**) Term: **14 Years**
- (21) Appl. No.: **29/345,835**
- (22) Filed: **Oct. 22, 2009**
- (30) **Foreign Application Priority Data**
Sep. 2, 2009 (JP) 2009-020183
- (51) **LOC (9) Cl.** **12-15**
- (52) **U.S. Cl.** **D12/605**
- (58) **Field of Classification Search** D12/500–501,
D12/544, 579, 600, 605, 604; 152/523–524,
152/DIG. 12, 555; D7/588, 396.4–396.5
See application file for complete search history.

(56) **References Cited**

U.S. PATENT DOCUMENTS

D91,322 S *	1/1934	James	D12/605
D373,751 S *	9/1996	Barrese	D12/605
D386,455 S *	11/1997	Clementz et al.	D12/605
D412,476 S *	8/1999	Clementz et al.	D12/605
6,032,711 A *	3/2000	Barrese et al.	152/523
D475,345 S *	6/2003	Endo et al.	D12/605
D552,537 S *	10/2007	Franks et al.	D12/605
D569,338 S *	5/2008	Shondel	D12/605
D577,330 S *	9/2008	Miyasaka	D12/605
D588,529 S *	3/2009	Reese et al.	D12/605

D598,843 S * 8/2009 Maxwell D12/605

FOREIGN PATENT DOCUMENTS

JP	1155729	10/2002
JP	1213079	8/2004

* cited by examiner

Primary Examiner—Stacia Cadmus

(74) *Attorney, Agent, or Firm*—Sterne Kessler Goldstein & Fox PLLC

(57) **CLAIM**

The ornamental design for a tire, as shown and described.

DESCRIPTION

FIG. 1 is a perspective view of a tire showing my new design;
 FIG. 2 is a front view thereof;
 FIG. 3 is a rear view thereof;
 FIG. 4 is a left side view, for which the right side view is a mirror image;
 FIG. 5 is a top plan view thereof, for which the bottom plan view is a mirror image;
 FIG. 6 is an enlarged sectional view taken along lines 6—6 and 6'—6' in FIG. 2;
 FIG. 7 is a cross sectional view taken along line 7,8—7,8 in FIG. 5 and in lines 7—7 and 7'—7' in FIG. 6; and,
 FIG. 8 is a cross sectional view taken along line 7,8—7,8 in FIG. 5 and in lines 8—8 and 8'—8' in FIG. 6.

The broken lines in the Figures show portions of the tire that form no part of the claimed design.

1 Claim, 6 Drawing Sheets

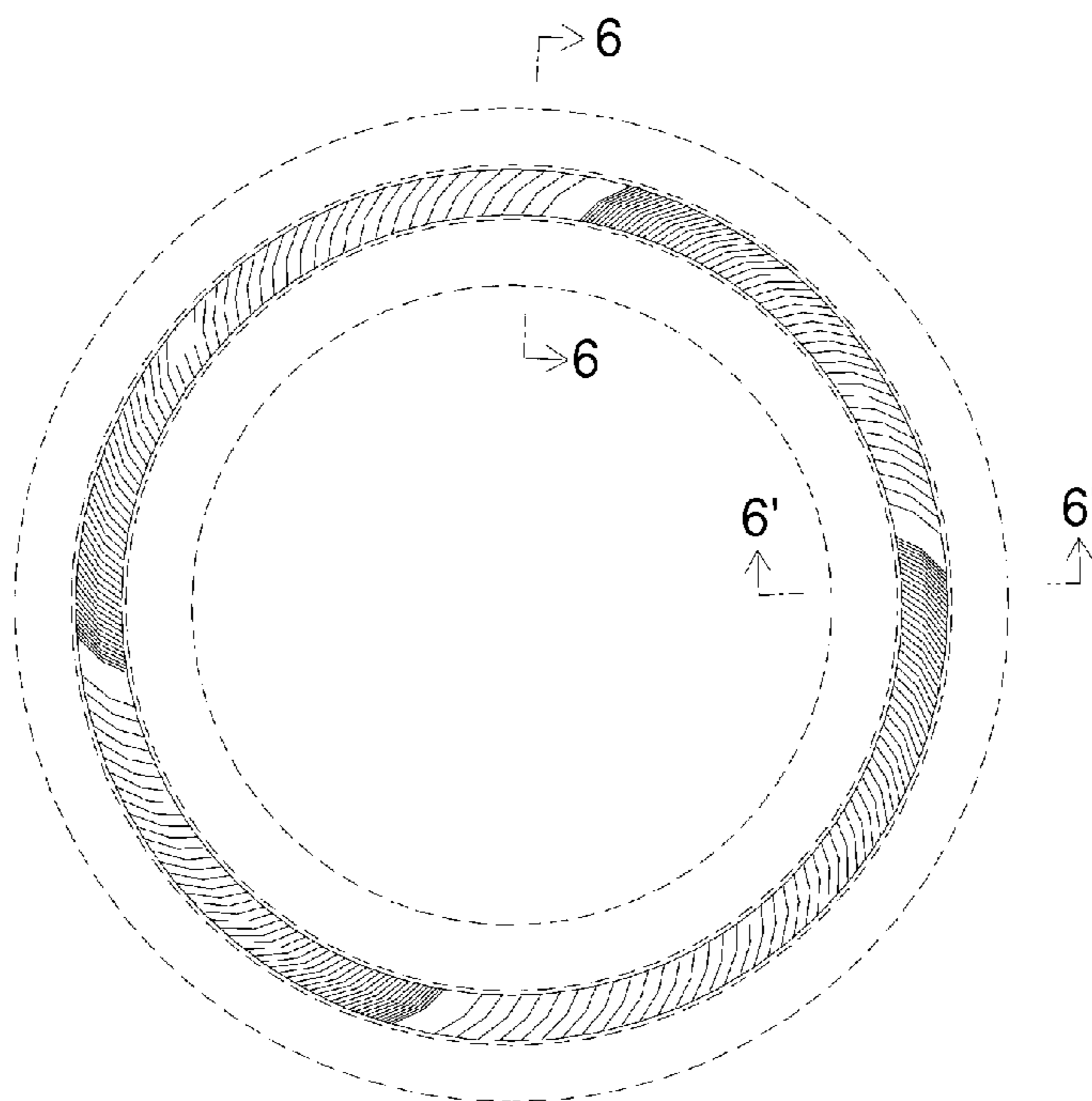

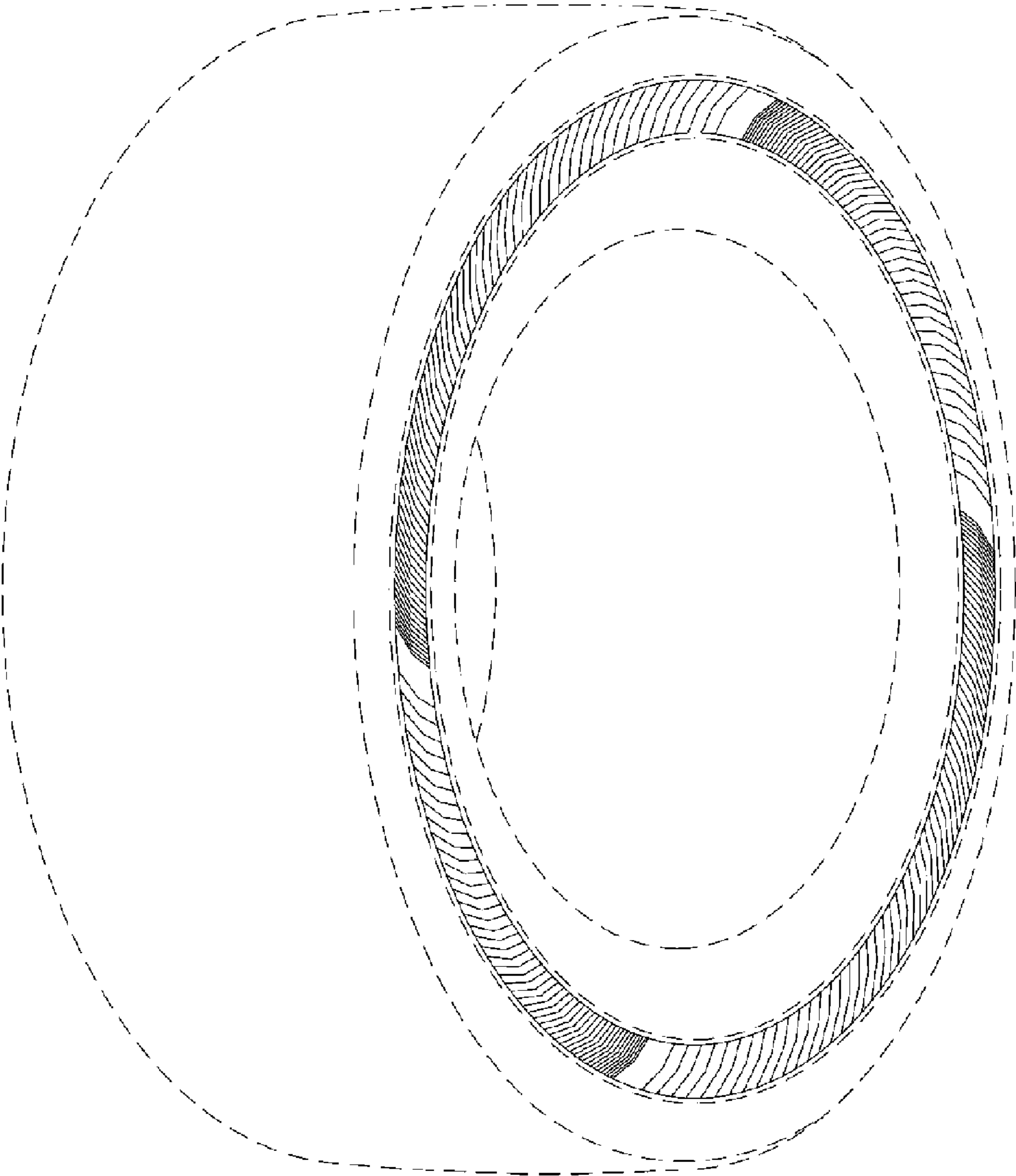

FIGURE 1

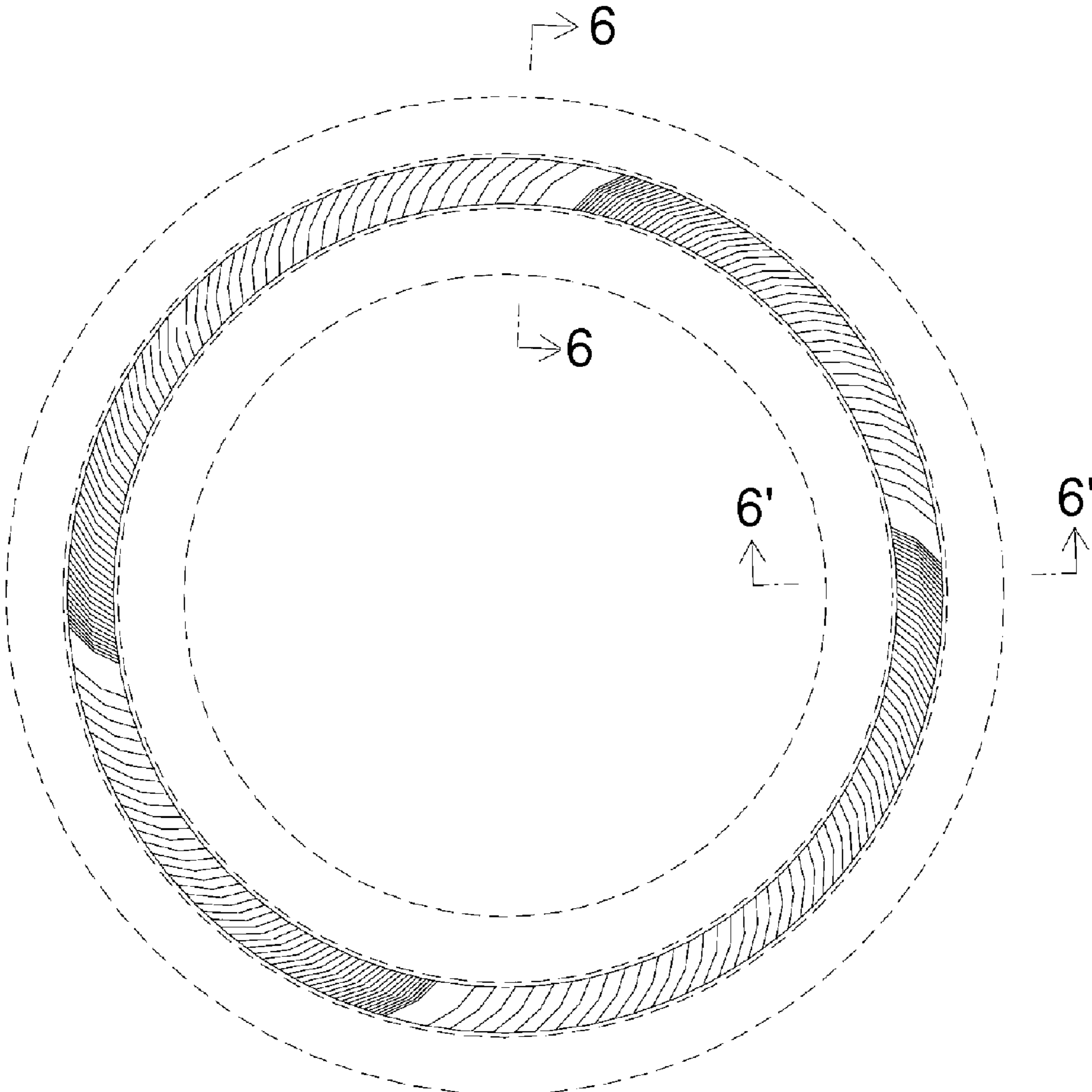

FIGURE 2

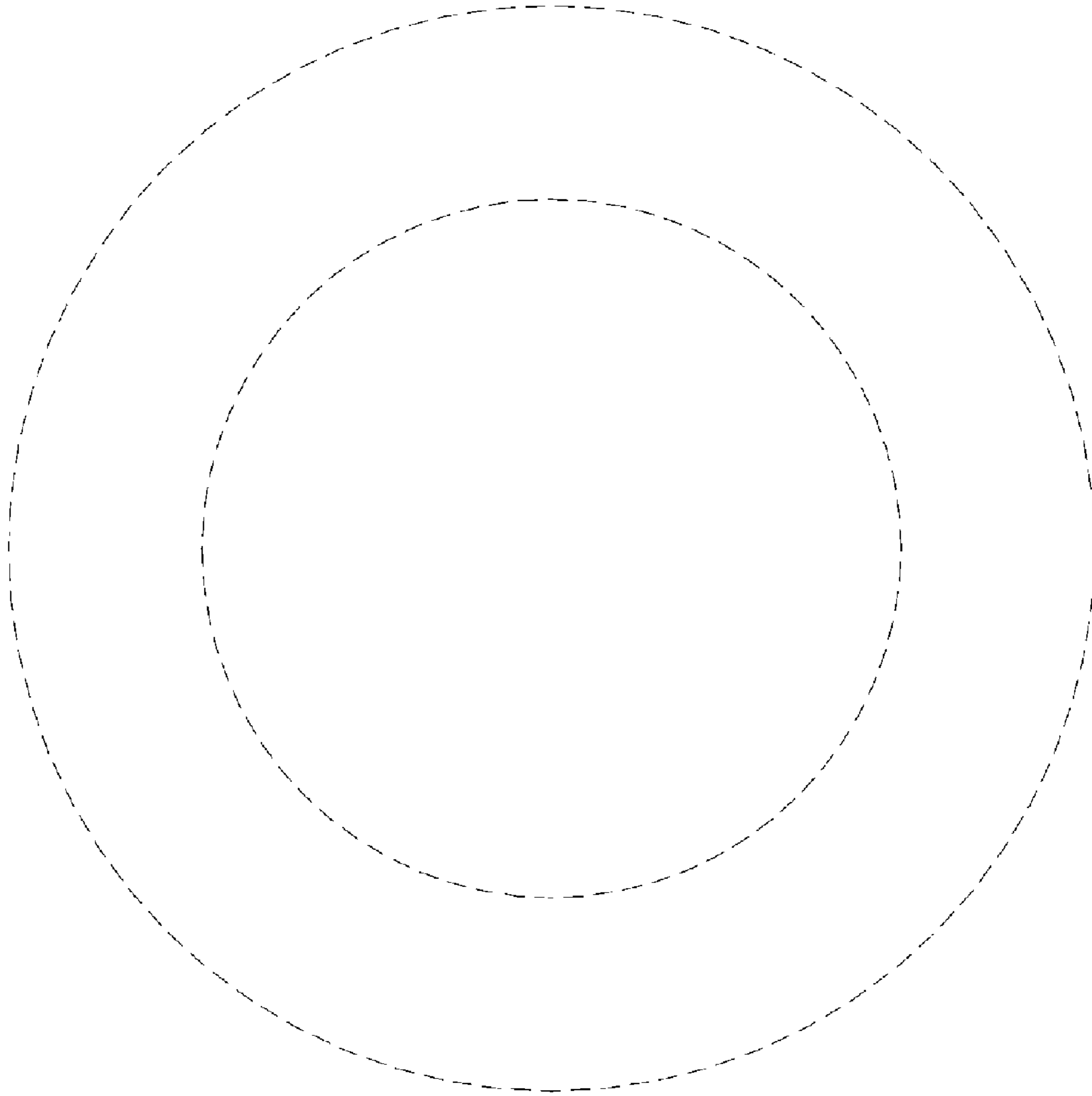

FIGURE 3

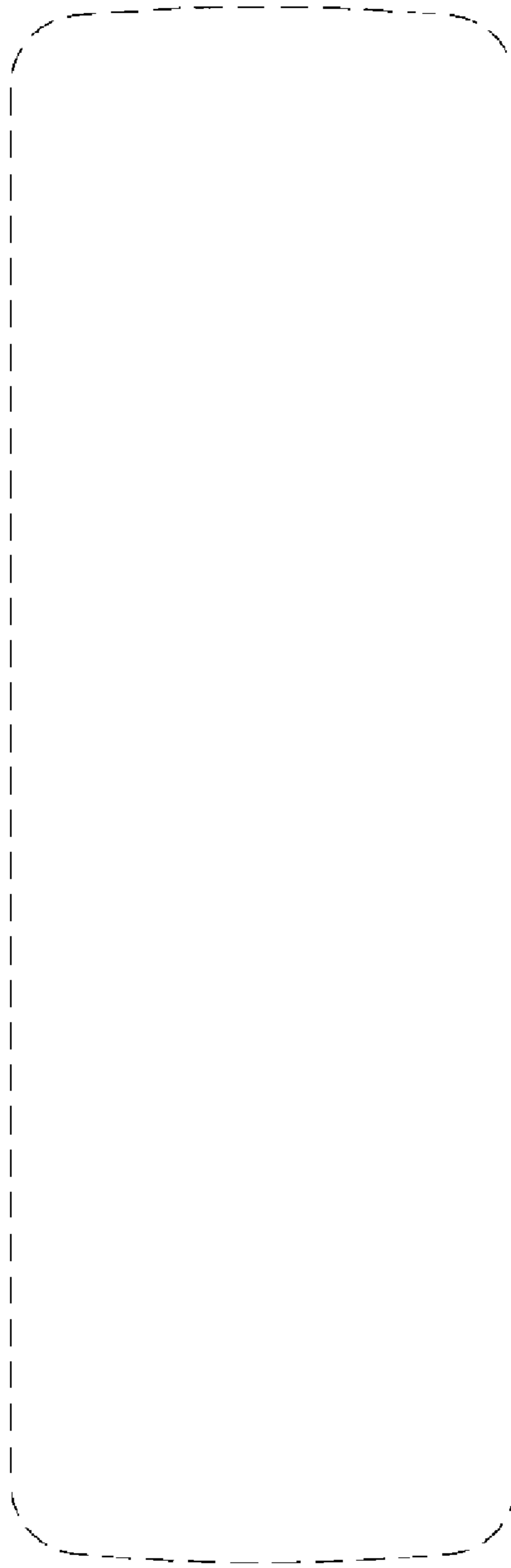

FIGURE 4

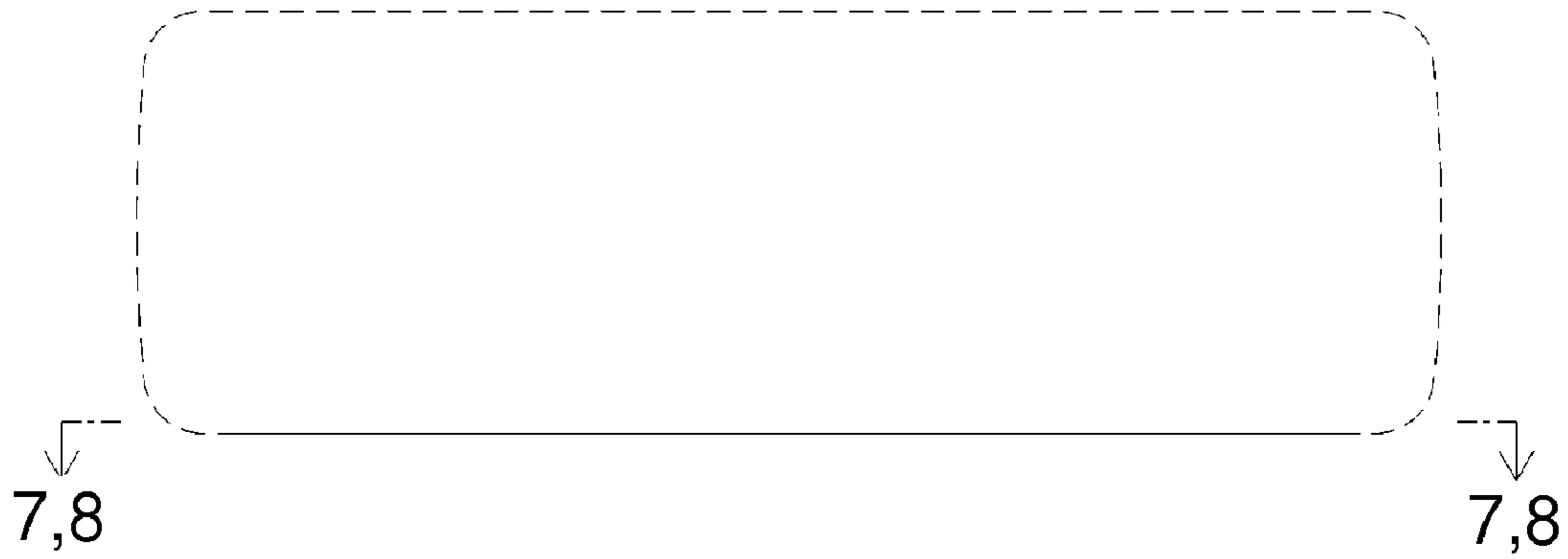

FIGURE 5

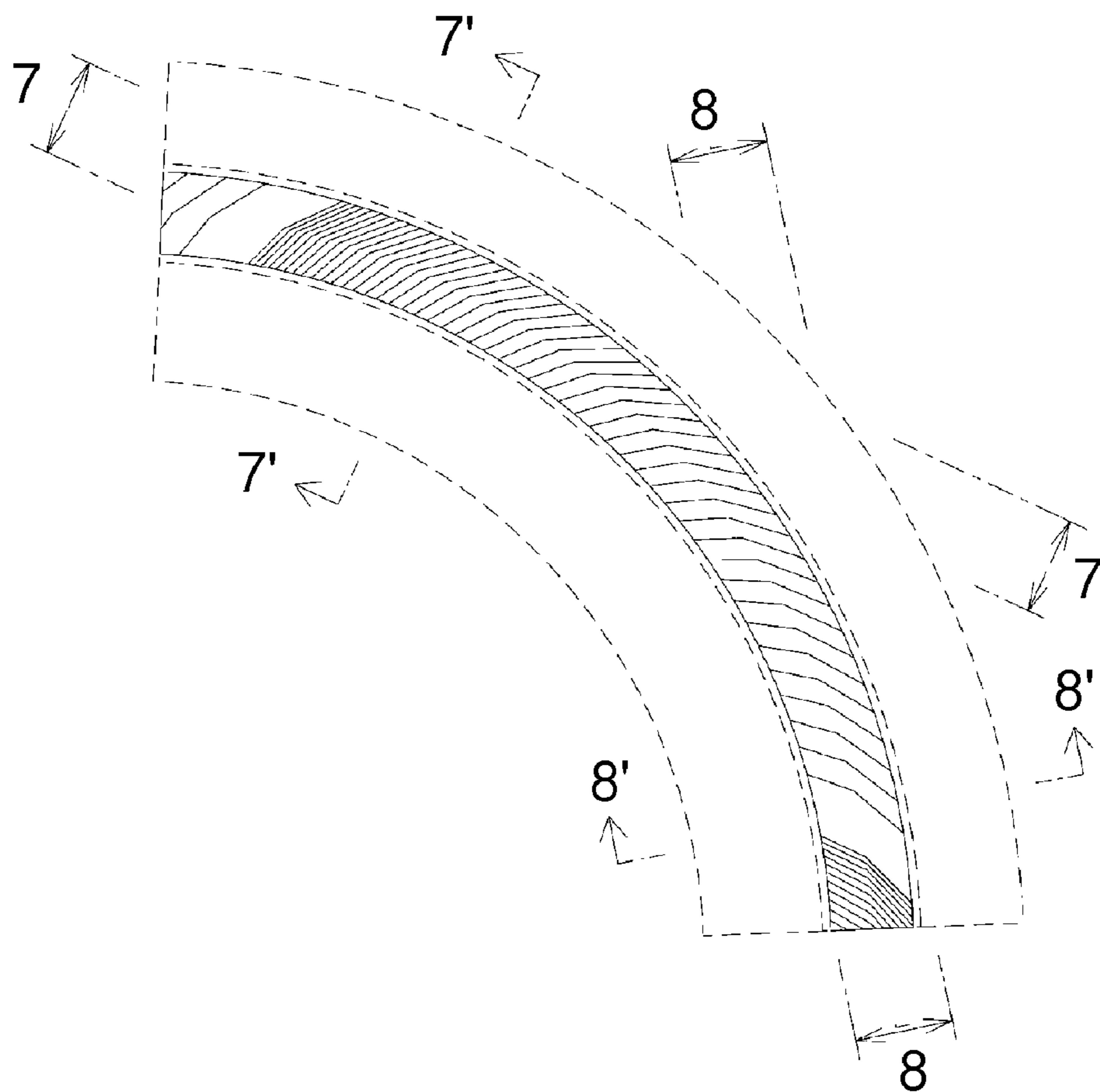

FIGURE 6



FIGURE 7

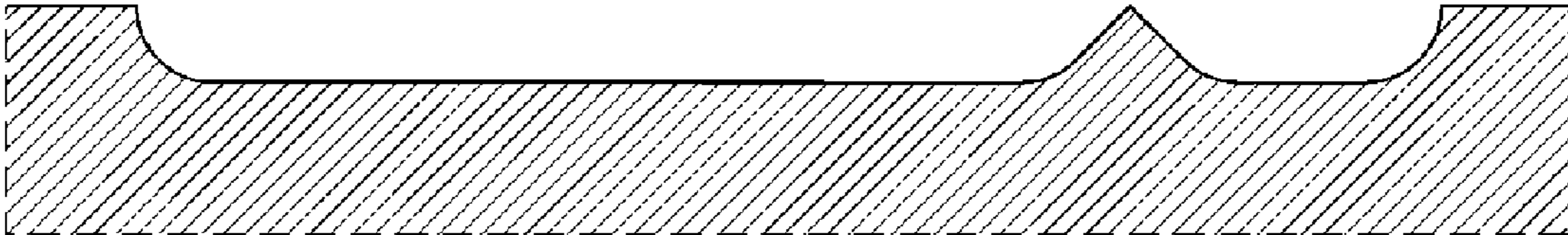

FIGURE 8