



US00D611401S

(12) **United States Design Patent**
Saint-Jalmes et al.

(10) **Patent No.:** **US D611,401 S**
(45) **Date of Patent:** **** Mar. 9, 2010**

(54) **AIRCRAFT FURNITURE**

(75) Inventors: **Bruno Saint-Jalmes**, Toulouse (FR);
Jason Zaneboni, Blagnac (FR);
Bernard Rumeau, Cornebarrieu (FR)

(73) Assignee: **Airbus SAS**, Blagnac Cedex (FR)

(**) Term: **14 Years**

(21) Appl. No.: **29/281,157**

(22) Filed: **Jun. 15, 2007**

(51) **LOC (9) Cl.** **12-07**

(52) **U.S. Cl.** **D12/425; D12/345**

(58) **Field of Classification Search** D12/317-319,
D12/345, 400, 415, 419, 423-426, 426.1;
244/117 R, 119; D6/396, 432, 439, 440;
D9/436, 448-449, 475-476

See application file for complete search history.

(56) **References Cited**

U.S. PATENT DOCUMENTS

D304,263 S *	10/1989	Mull	D12/419
D450,651 S *	11/2001	Walterscheid et al.	D12/424
D453,138 S *	1/2002	Walterscheid et al.	D12/424
6,422,440 B1 *	7/2002	Stone	224/275
D478,102 S *	8/2003	Utsugi	D15/83
D478,860 S *	8/2003	Young	D12/419
D484,843 S *	1/2004	Wyszogrod	D12/419

OTHER PUBLICATIONS

U.S. Appl. No. 29/281,139. Title: Aircraft Lighting Effect, filed Jun. 15, 2007.

U.S. Appl. No. 29/281,143. Title: Aircraft Ceiling, filed Jun. 15, 2007.

U.S. Appl. No. 29/281,141. Title: Aircraft Module, filed Jun. 15, 2007.

U.S. Appl. No. 29/281,145. Title: Aircraft Seat, filed Jun. 15, 2007.

* cited by examiner

Primary Examiner—Ian Simmons

Assistant Examiner—Dana L Sipos

(74) *Attorney, Agent, or Firm*—Osler, Hoskin & Harcourt LLP

(57) **CLAIM**

The ornamental design for aircraft furniture, as shown and described

DESCRIPTION

FIG. 1 is a top, rear, right side perspective view of a piece of aircraft furniture according to our design;

FIG. 2 is a top plan view thereof;

FIG. 3 is a left side elevation view thereof;

FIG. 4 is a rear elevation view thereof;

FIG. 5 is a front elevation view thereof; and,

FIG. 6 is a top, rear, right side perspective view of the piece of aircraft furniture of FIG. 1 shown with unclaimed environmental structure of additional elements of an aircraft cockpit.

Throughout the Figures, the dashed broken lines represent environmental matter and/or unclaimed portions of the aircraft furniture and form no part of the claimed design. The dash-dot broken lines represent the boundary between claimed and unclaimed areas and form no part of the claimed design.

Unshaded portions of the article and portions of the article not shown in the drawings, form no part of the claimed design.

1 Claim, 6 Drawing Sheets

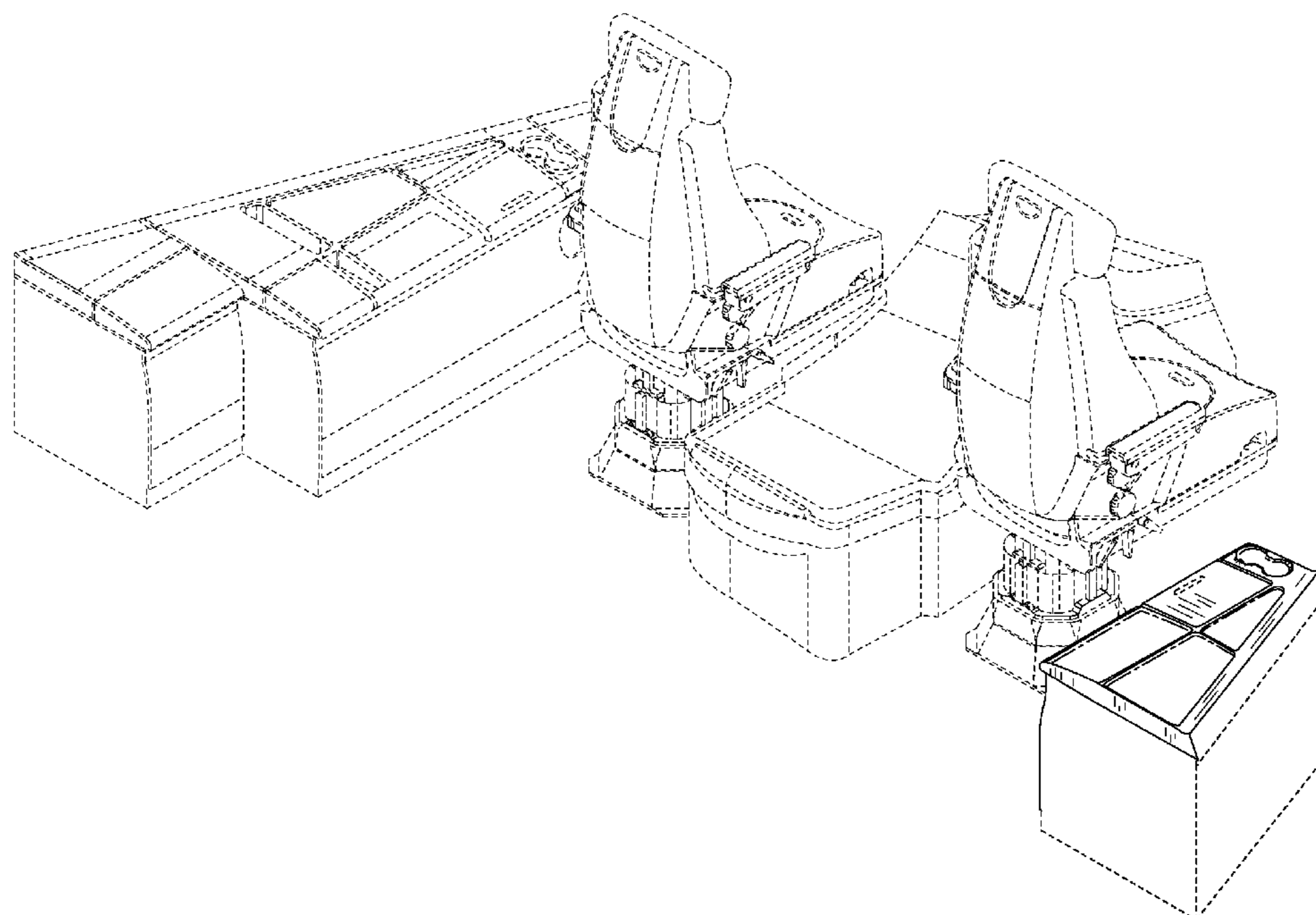

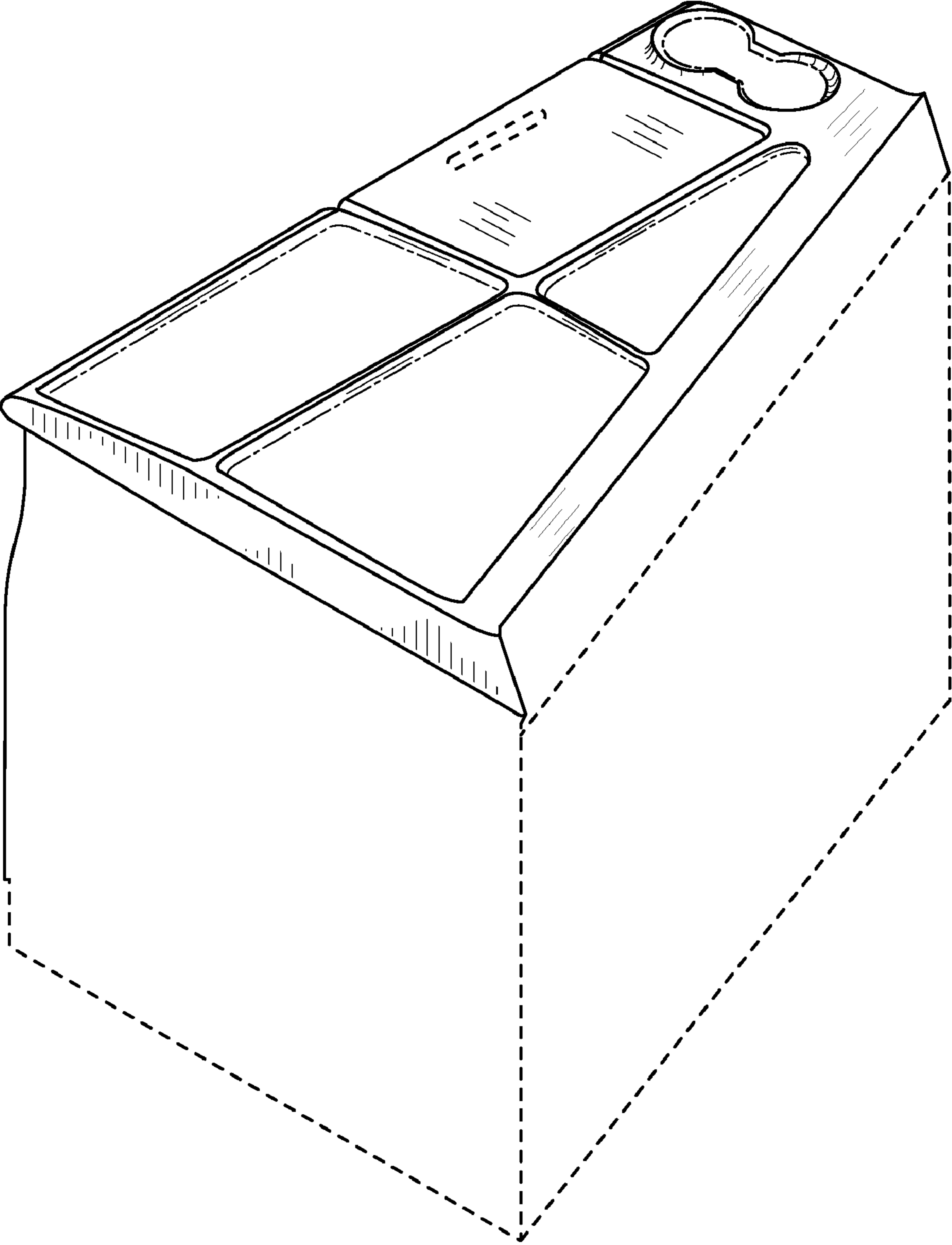

FIG. 1

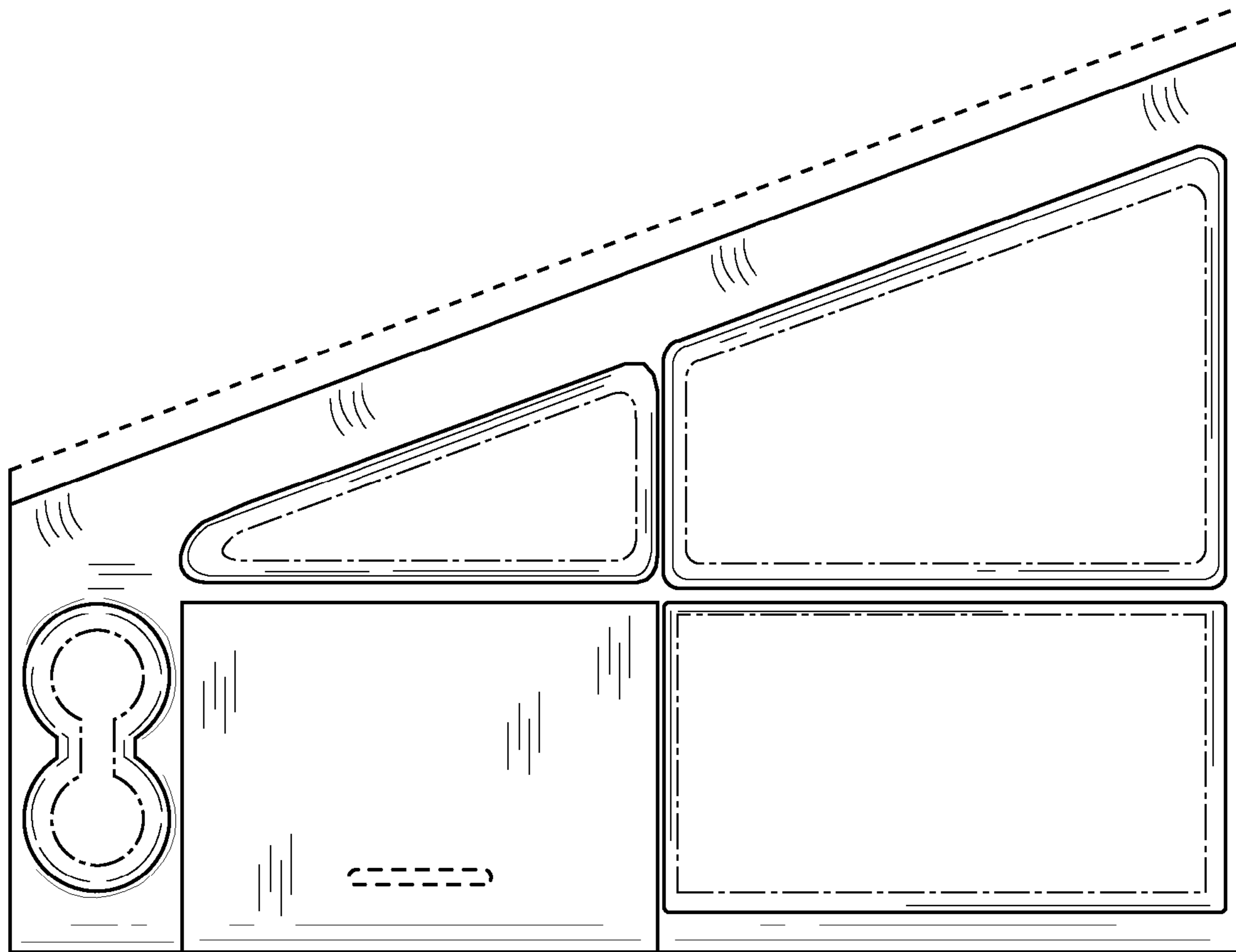

FIG. 2

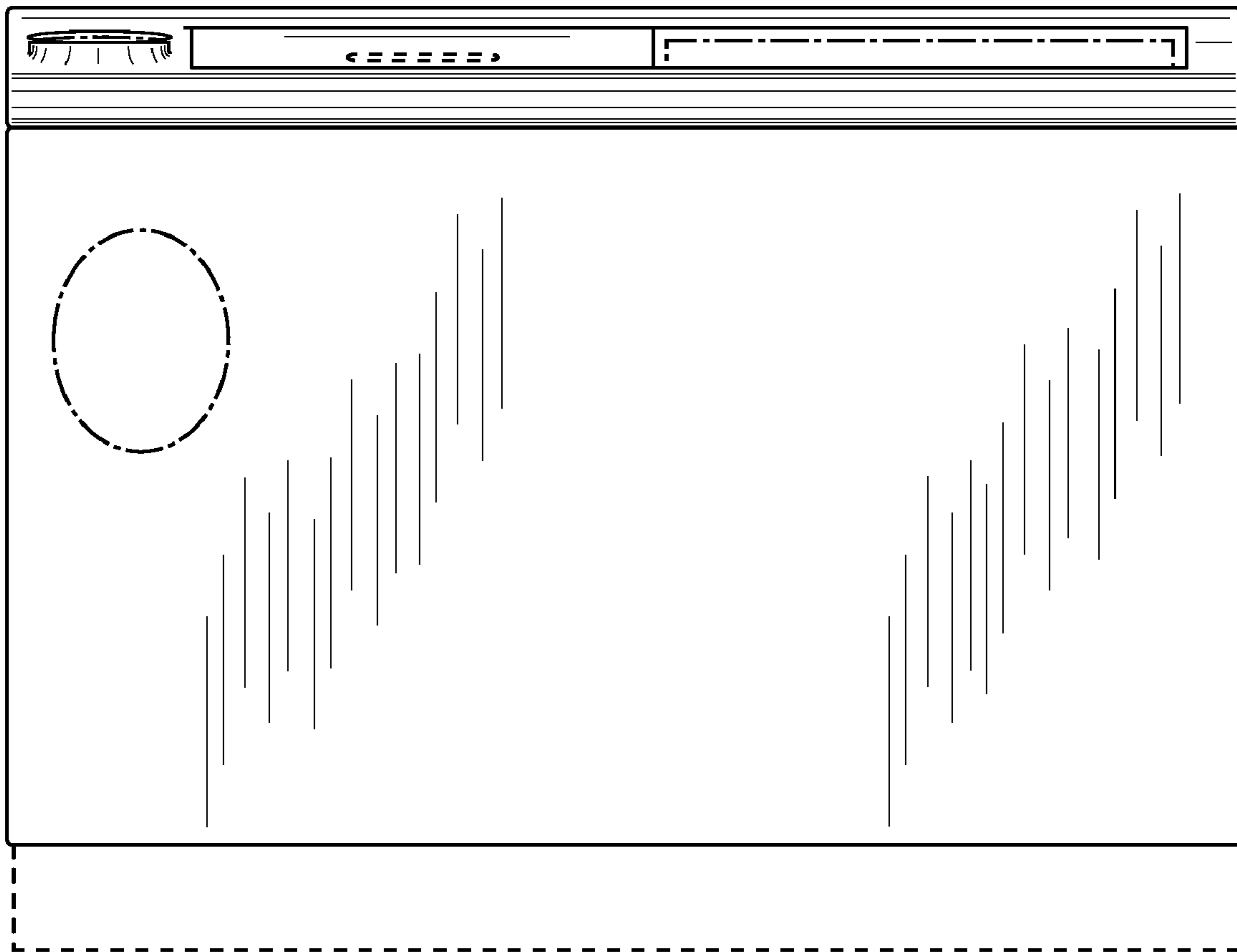

FIG. 3

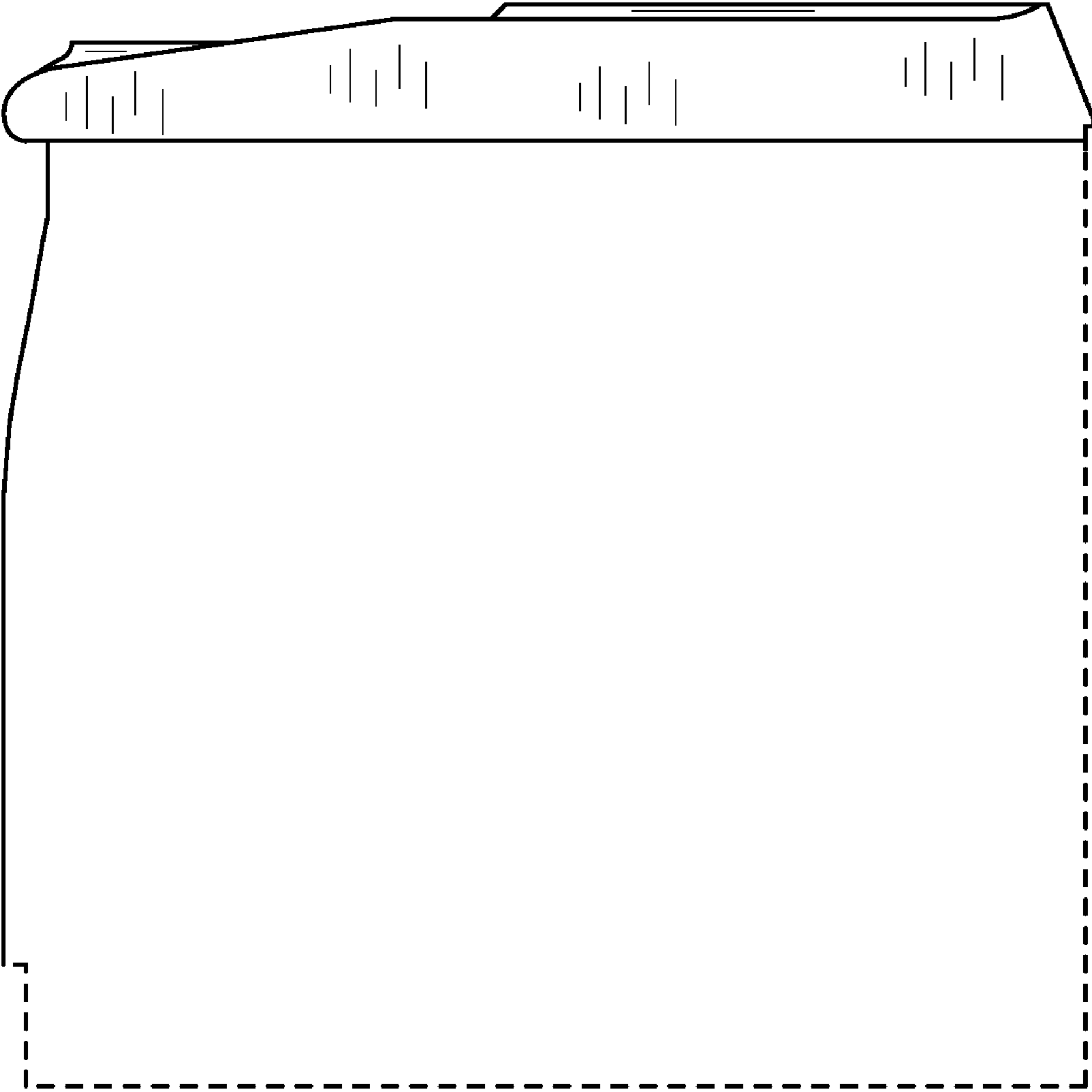

FIG. 4

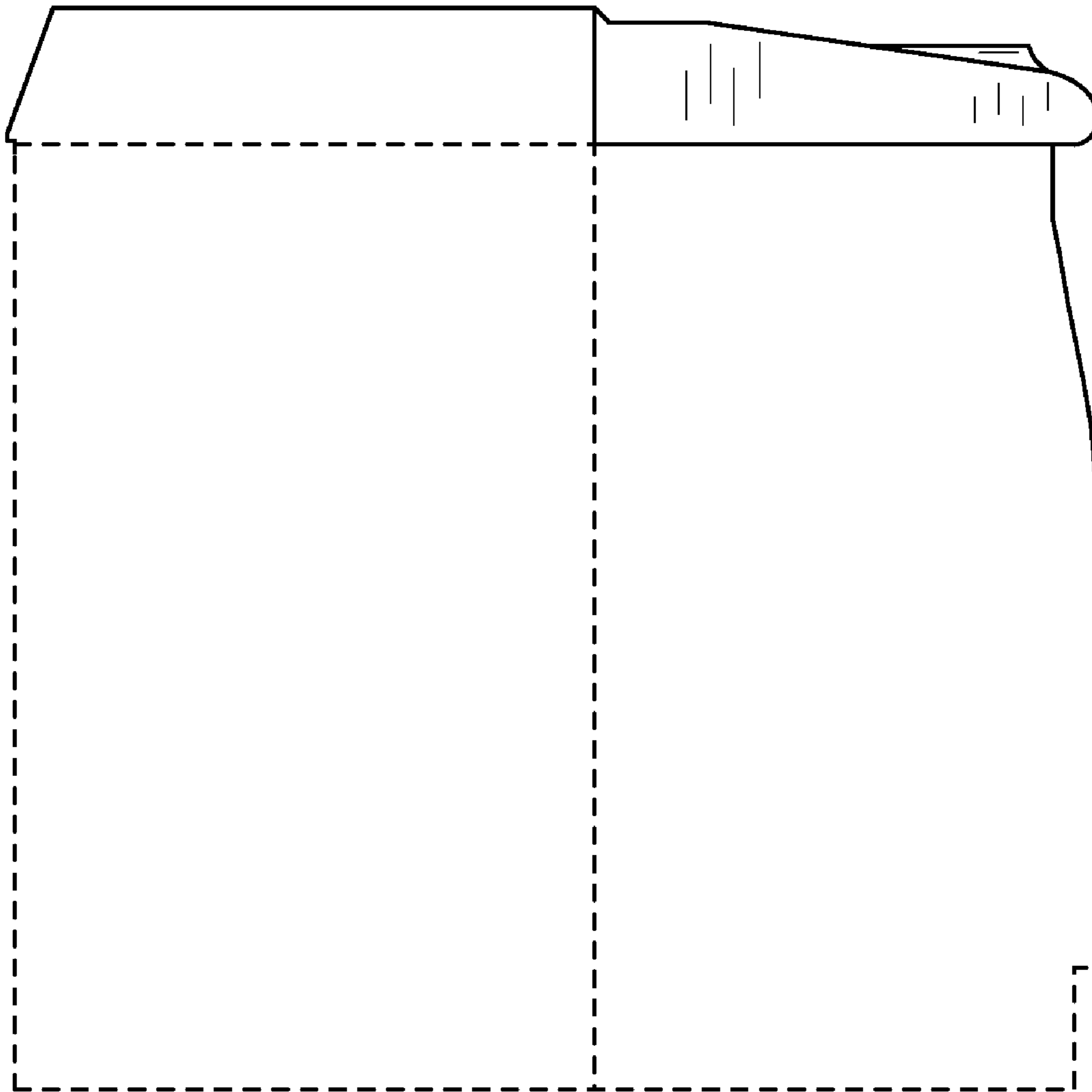

FIG. 5

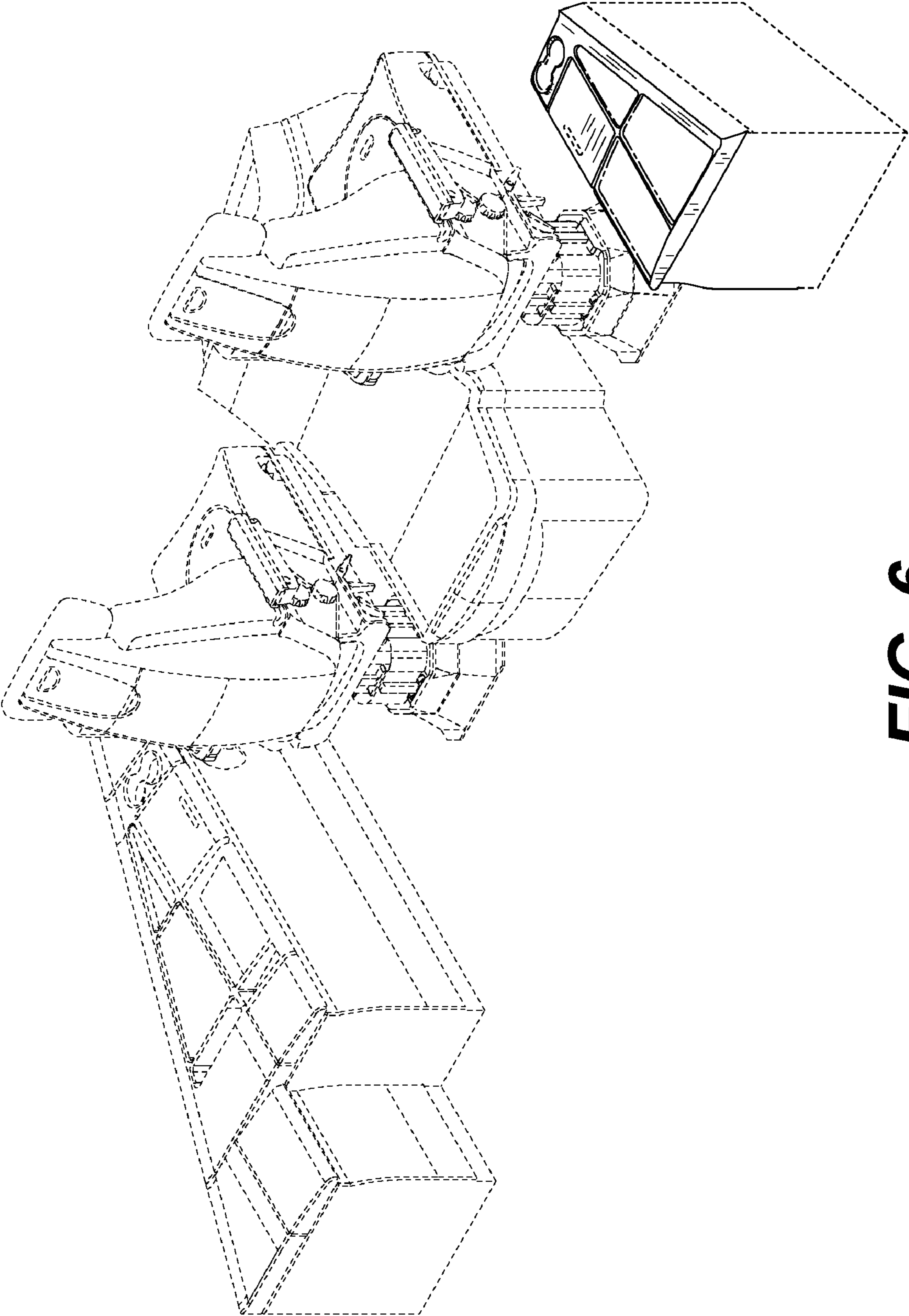

FIG. 6