



US00D611335S

(12) **United States Design Patent**  
**Carbonero**

(10) **Patent No.:** **US D611,335 S**  
(45) **Date of Patent:** **\*\* Mar. 9, 2010**

(54) **CONE CROSS BAR END FITTING**

(75) Inventor: **Kurt K. Carbonero**, Mt. Pleasant, SC  
(US)

(73) Assignee: **Pull-Buoy, Inc.**, Sterling Heights, MI  
(US)

(\*\*) Term: **14 Years**

(21) Appl. No.: **29/345,107**

(22) Filed: **Oct. 9, 2009**

(51) **LOC (9) Cl.** ..... **08-08**

(52) **U.S. Cl.** ..... **D8/396**

(58) **Field of Classification Search** ..... D8/356,  
D8/383, 394-396; 24/16 PB, 17 AP, 30.5 P,  
24/30.5 S, 300-302, 339, DIG. 16; 248/58,  
248/60, 74.3; 70/16; 128/878

See application file for complete search history.

(56) **References Cited**

**U.S. PATENT DOCUMENTS**

D214,153 S *	5/1969	Merser	.....	D8/388
3,462,802 A *	8/1969	Merser	.....	24/16 PB
3,466,077 A *	9/1969	Moberg	.....	292/322
3,712,655 A *	1/1973	Fuehrer	.....	292/321
3,780,400 A *	12/1973	Hinsperger	.....	24/16 PB
4,586,570 A *	5/1986	Swift	.....	169/75
D323,972 S *	2/1992	Rowland	.....	D8/394
D355,054 S *	1/1995	Self	.....	D29/129

\* cited by examiner

*Primary Examiner*—T. Chase Nelson  
*Assistant Examiner*—John Windmuller

(74) *Attorney, Agent, or Firm*—Honigman Miller Schwartz  
and Cohn LLP

(57) **CLAIM**

The ornamental design for a cone cross bar end fitting, as  
shown and described.

**DESCRIPTION**

FIG. 1 shows a front, top perspective view of the cone cross  
bar end fitting. The broken line showing of the cross bar is for  
the purpose of illustrating the environment and forms no part  
of the claimed design.

FIG. 2 shows a top view of the cone cross bar end fitting. The  
broken line showing of the cross bar is for the purpose of  
illustrating the environment and forms no part of the claimed  
design.

FIG. 3 shows a first side view of the cone cross bar end fitting.  
The broken line showing of the cross bar is for the purpose of  
illustrating the environment and forms no part of the claimed  
design.

FIG. 4 shows a second side view of the cone cross bar end  
fitting. The broken line showing of the reinforcing ribs forms  
no part of the claimed design.

FIG. 5 shows a bottom view of the cone cross bar end fitting.  
The broken line showing of the reinforcing ribs forms no part  
of the claimed design.

FIG. 6 shows a front end view of the cone cross bar end fitting;  
and,

FIG. 7 shows a back end view of the cone cross bar end fitting.  
The broken line showing of the reinforcing ribs forms no part  
of the claimed design.

**1 Claim, 4 Drawing Sheets**

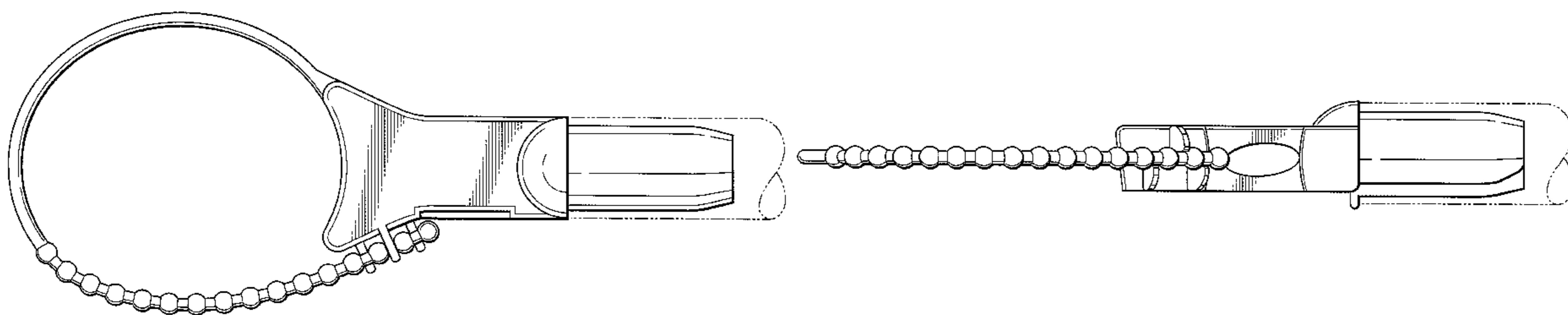

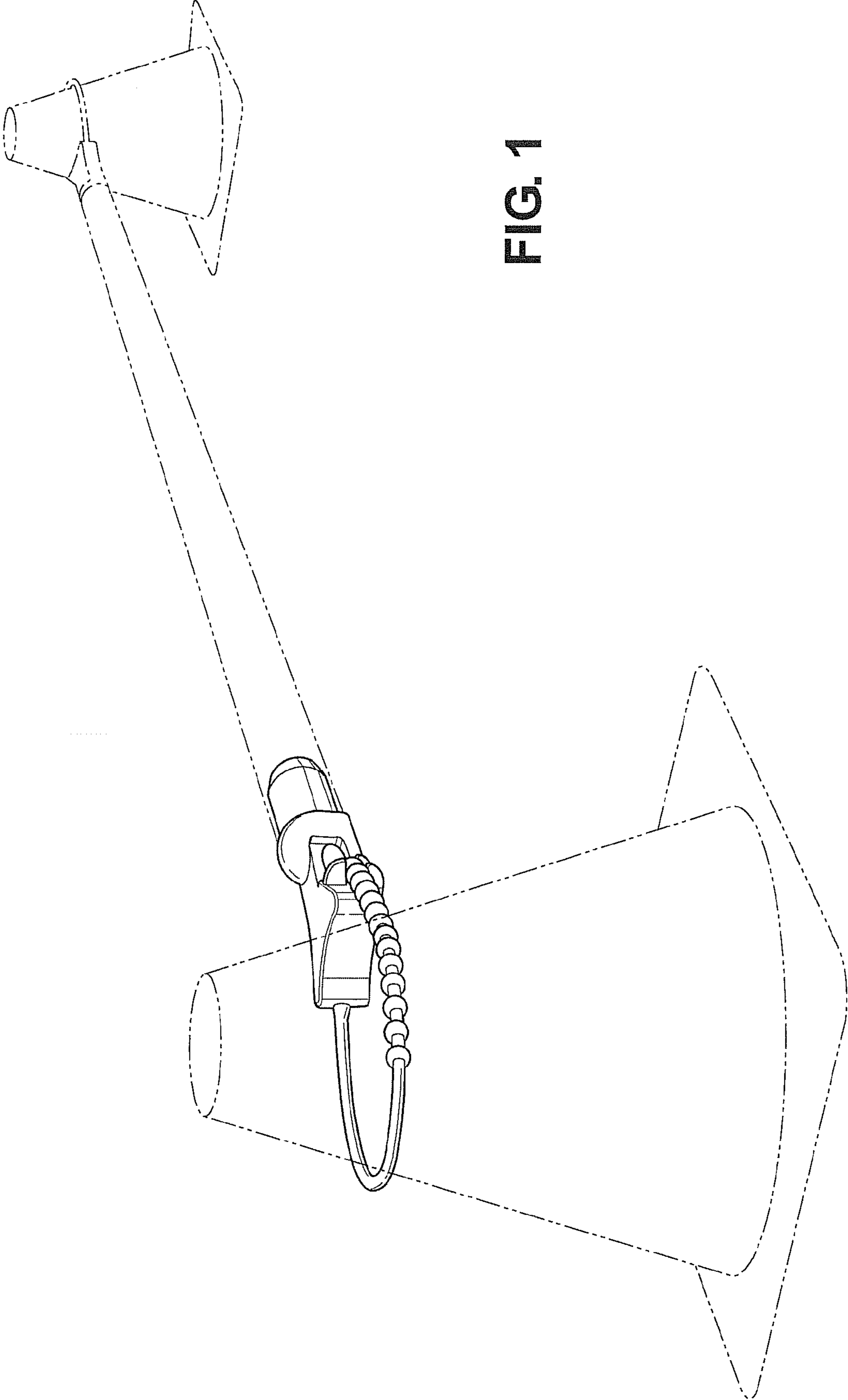

FIG. 1

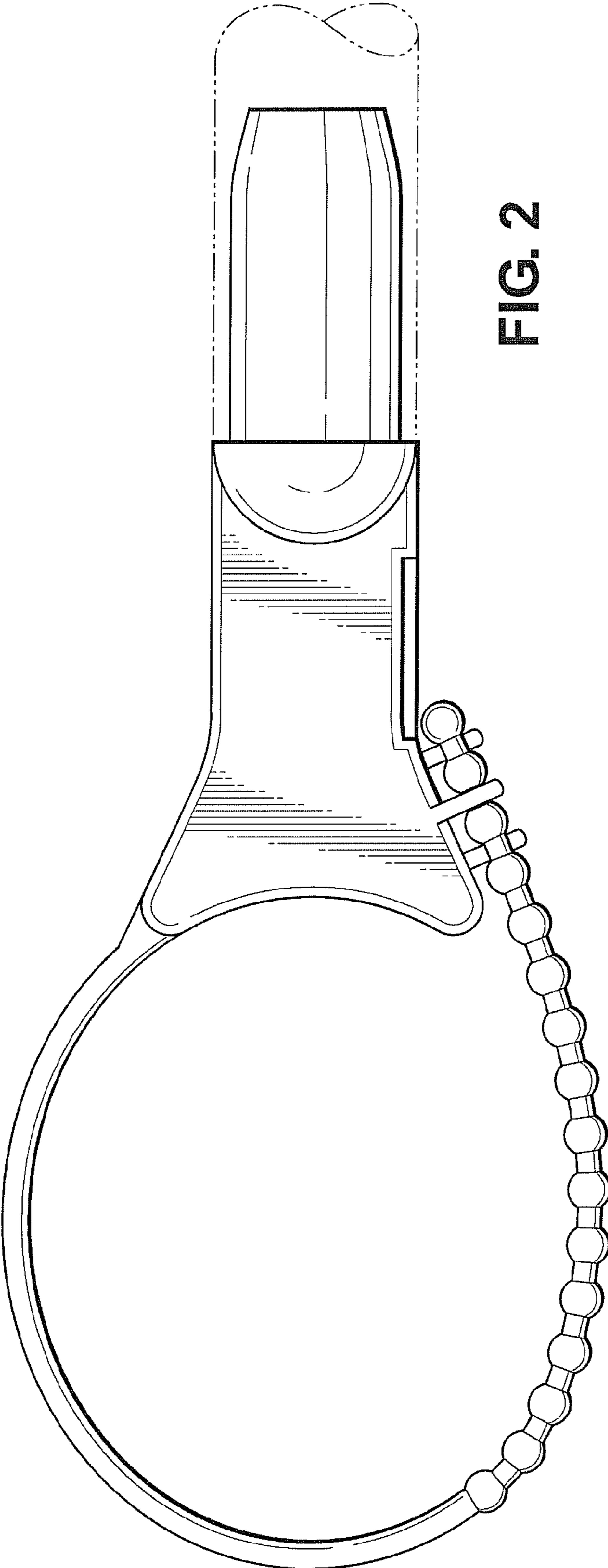

FIG. 2

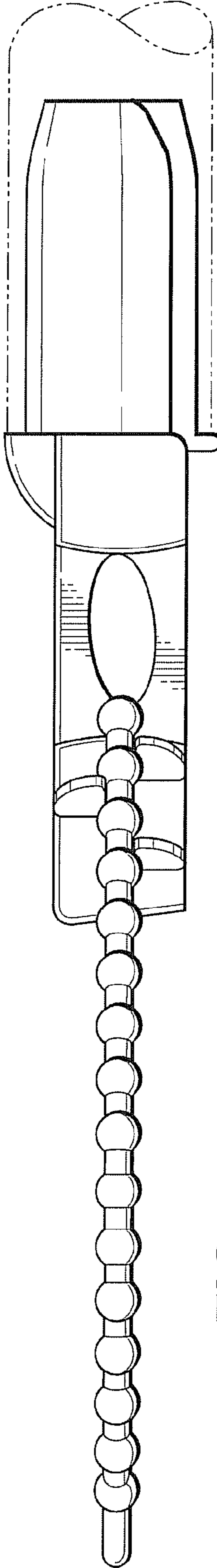

FIG. 3

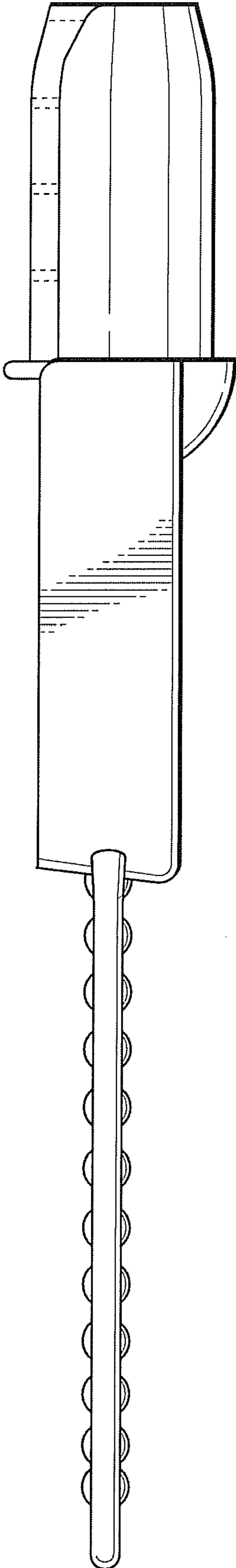

FIG. 4

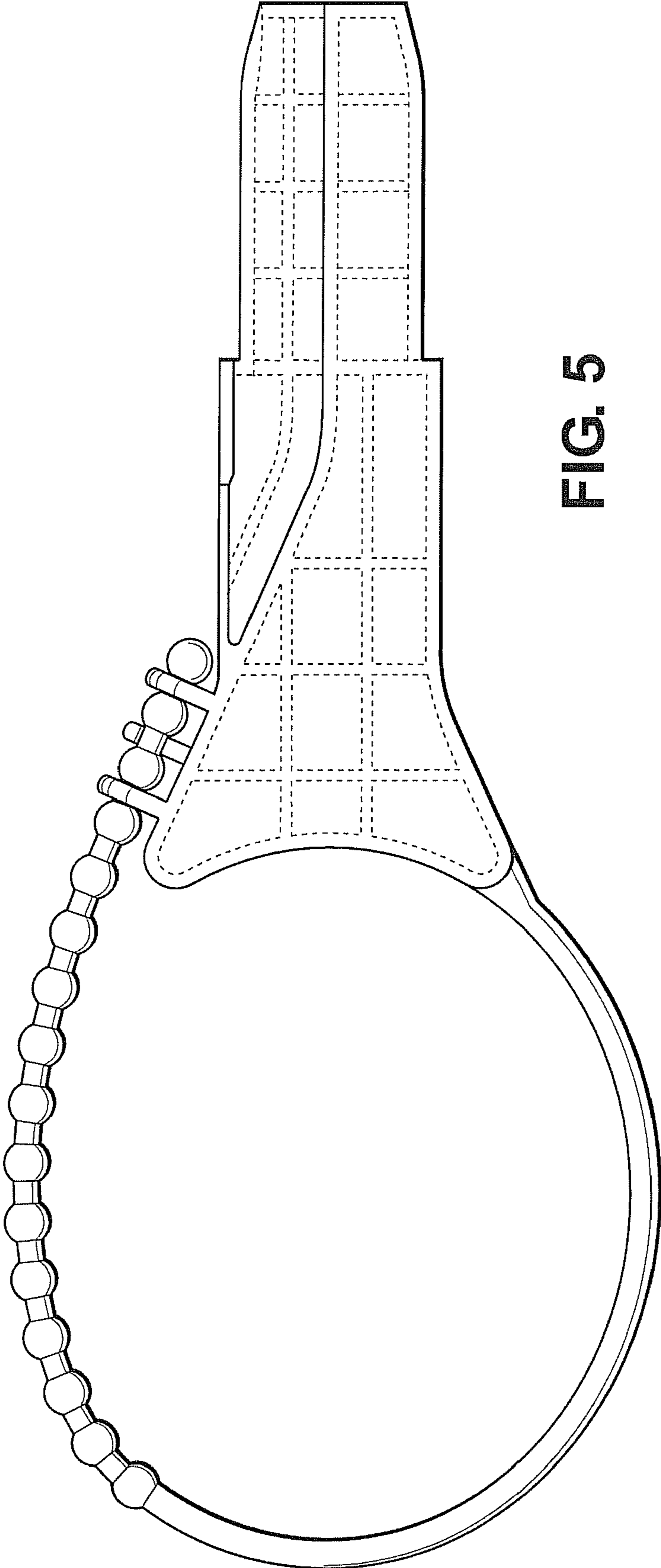
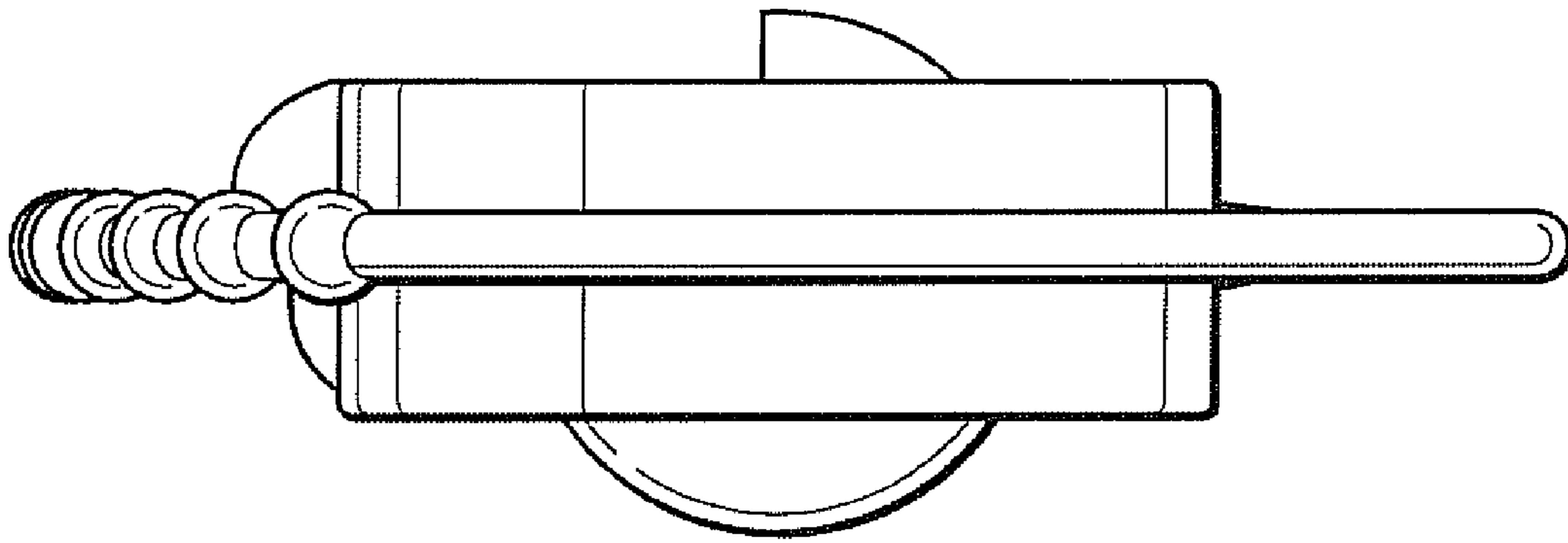
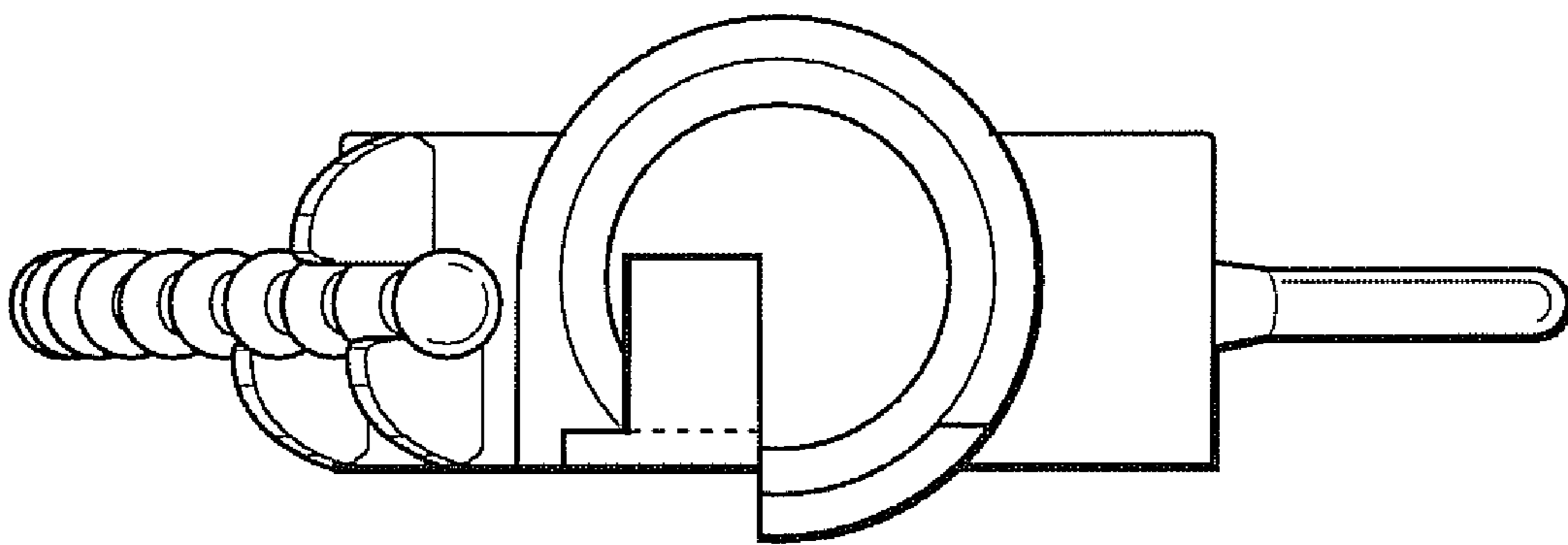

FIG. 5



**FIG. 6**



**FIG. 7**