



US00D611260S

(12) **United States Design Patent**
Plant

(10) **Patent No.:** **US D611,260 S**
(45) **Date of Patent:** **** Mar. 9, 2010**

(54) **PASSENGER SEATING ARRANGEMENT**

(75) **Inventor:** **Tommy George Plant**, Winston-Salem, NC (US)

(73) **Assignee:** **BE Aerospace, Inc.**, Wellington, FL (US)

(**) **Term:** **14 Years**

(21) **Appl. No.:** **29/339,824**

(22) **Filed:** **Jul. 8, 2009**

Related U.S. Application Data

(63) Continuation of application No. 11/737,203, filed on Apr. 19, 2007, now Pat. No. 7,578,470.

(51) **LOC (9) Cl.** **06-04**

(52) **U.S. Cl.** **D6/356**

(58) **Field of Classification Search** D6/334–336, D6/356, 360, 361, 367, 368, 381, 500–502; 297/232, 233, 244, 248, 342, 354.1, 354.11, 297/361.1; 244/118.5, 118.6, 122 R
See application file for complete search history.

(56) **References Cited**

U.S. PATENT DOCUMENTS

D249,306 S *	9/1978	Bengtsson	D6/342
D269,652 S *	7/1983	McKean et al.	D6/356
D402,125 S *	12/1998	Dryburgh et al.	D6/356
D405,275 S *	2/1999	Dryburgh et al.	D6/356
D409,010 S *	5/1999	Papaioannou et al.	D6/356
D411,922 S *	7/1999	Granados	D6/356
D439,425 S *	3/2001	Park et al.	D6/356
D443,990 S *	6/2001	Beroth	D6/356

D487,981 S *	4/2004	Ludeke et al.	D6/356
D493,294 S *	7/2004	Newson	D6/356
D510,816 S *	10/2005	Lee	D6/356
D591,520 S *	5/2009	Orson et al.	D6/356
D592,412 S *	5/2009	Suge et al.	D6/356

* cited by examiner

Primary Examiner—Mimosa De

(74) *Attorney, Agent, or Firm*—Adams Intellectual Property Law

(57) **CLAIM**

We claim the ornamental design for a passenger seating arrangement, as shown and described.

DESCRIPTION

FIG. 1 is a top plan view of the passenger seating arrangement according to the invention;

FIG. 2 is a side elevation view of the passenger seating arrangement according to the invention, one row thereof being shown separately for ease of illustration;

FIG. 3 is rear elevation view of the passenger seating arrangement according to the invention;

FIG. 4 is a perspective view of the passenger seating arrangement according to the invention;

FIG. 5 is another perspective view of the passenger seating arrangement according to the invention; and,

FIG. 6 is another side elevation view of the passenger seating arrangement according to the invention.

The broken lines shown in FIG. 1 are for illustration purposes only and form no part of the claimed design.

1 Claim, 6 Drawing Sheets

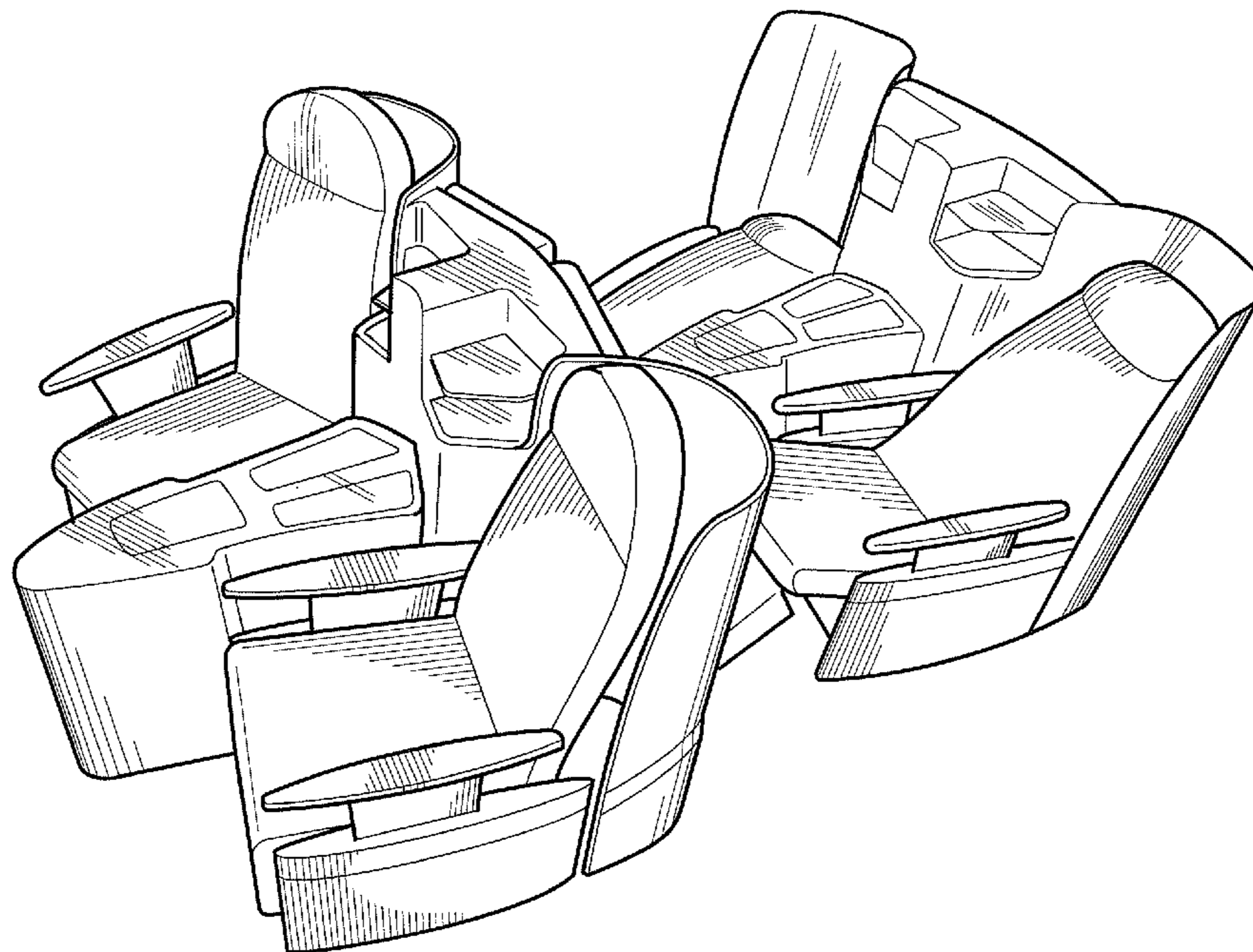

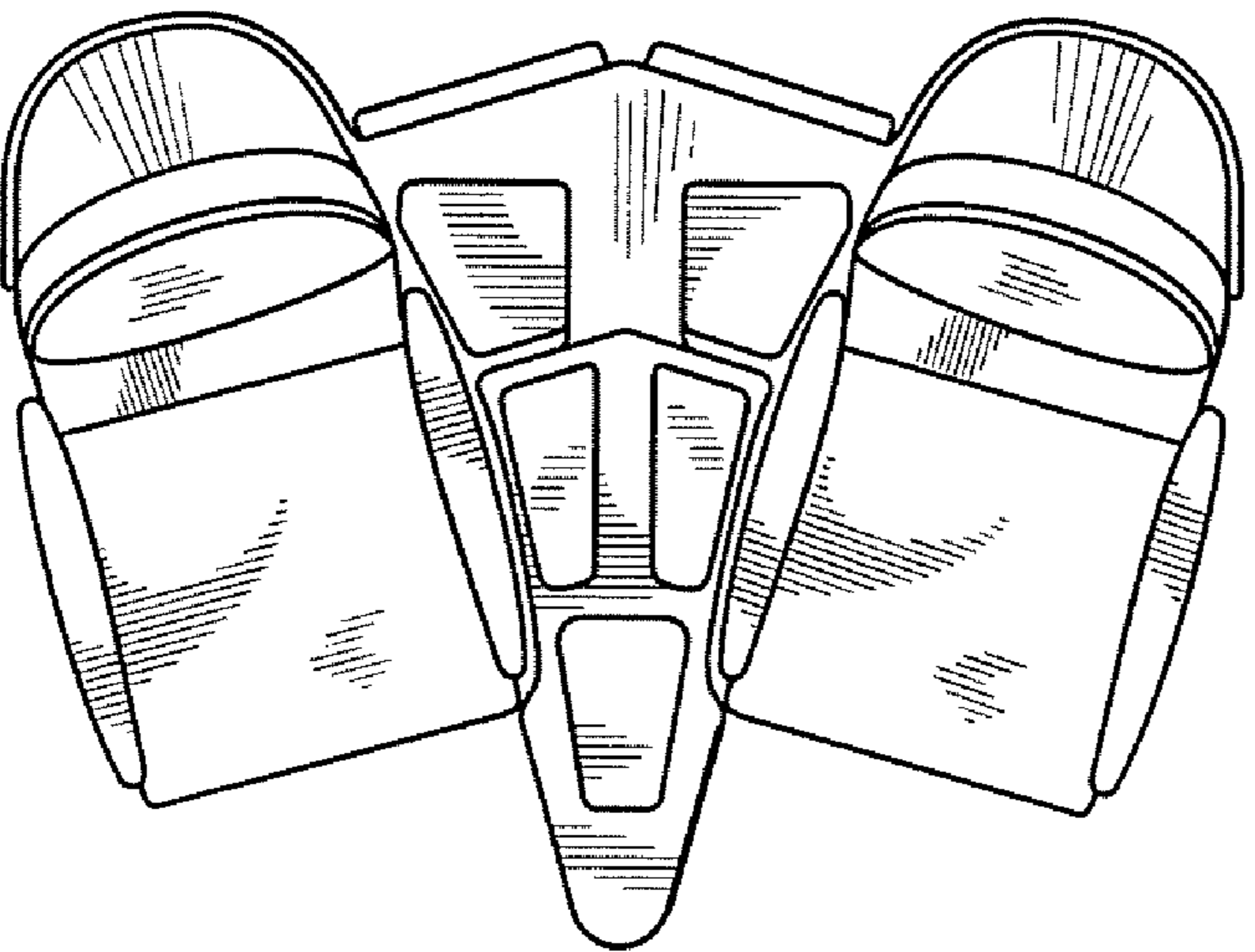
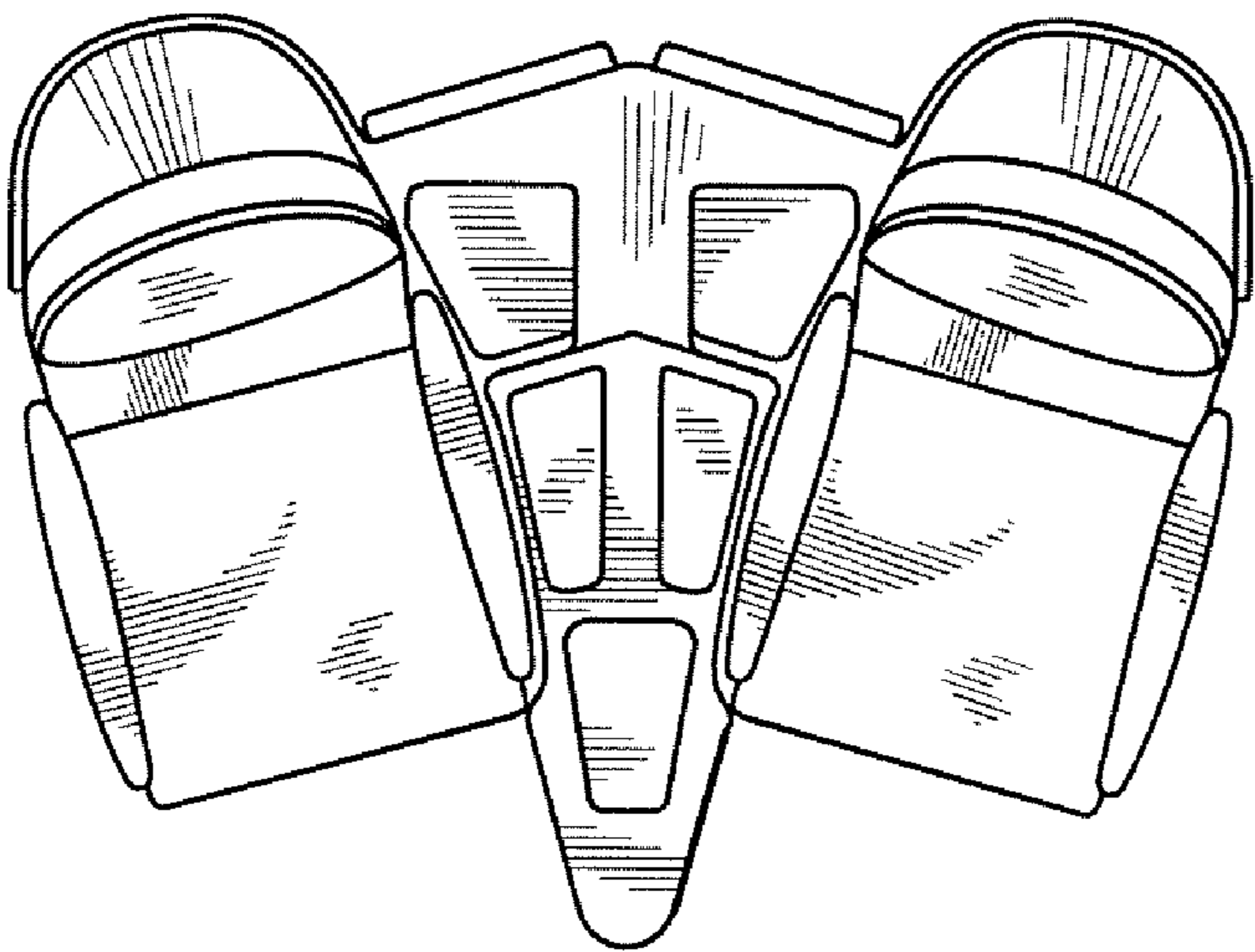
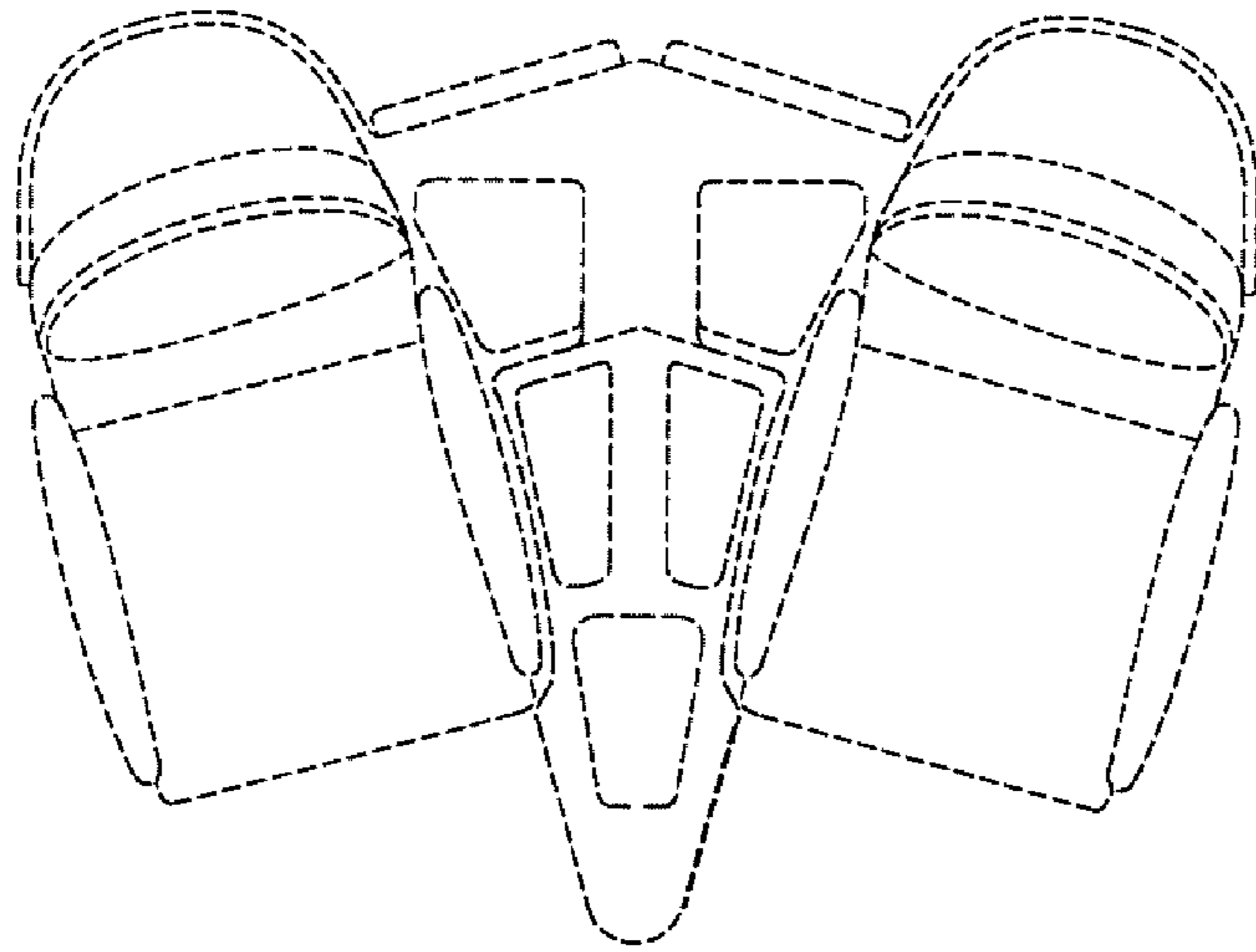

Fig. 1

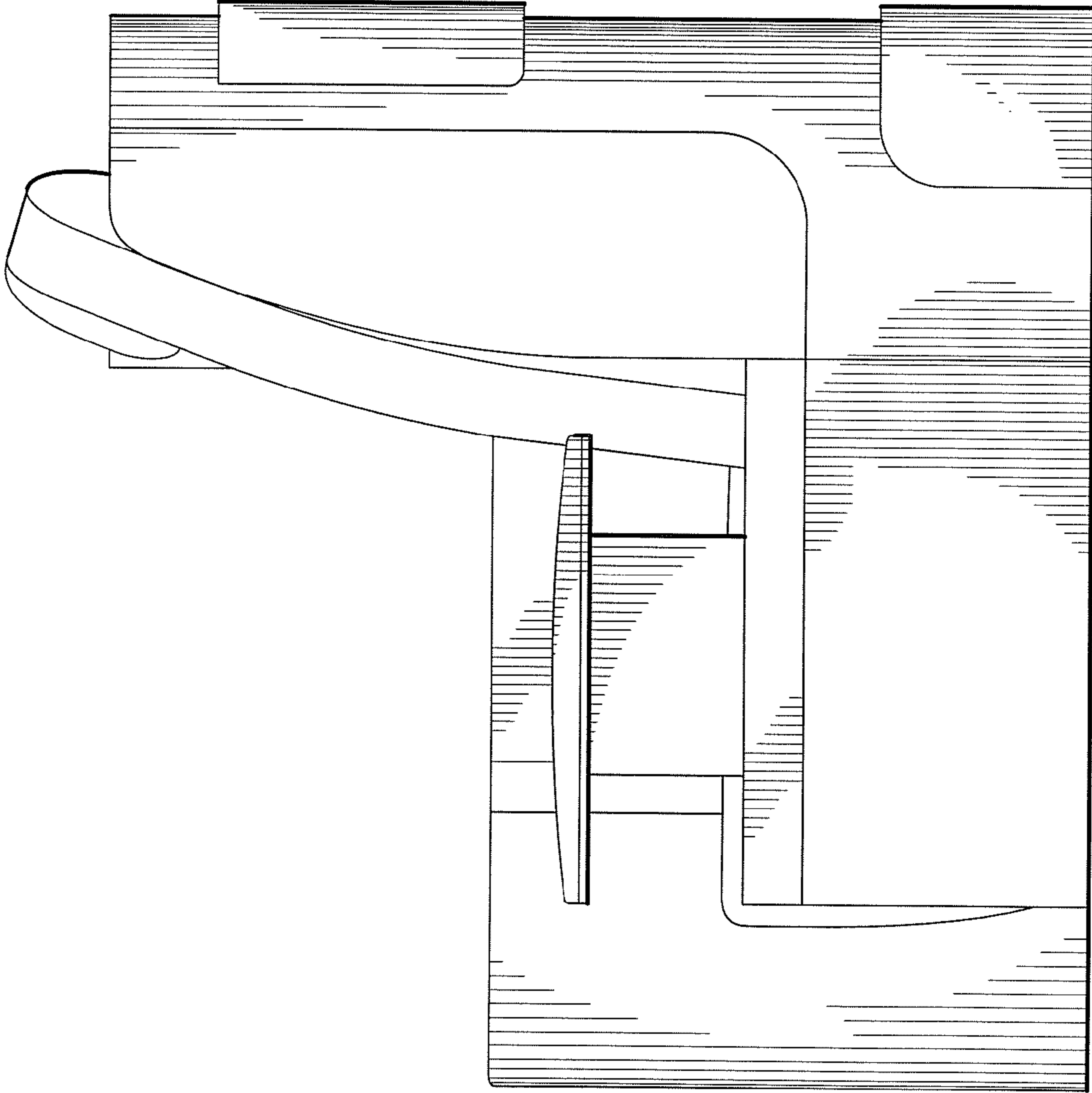

Fig. 2

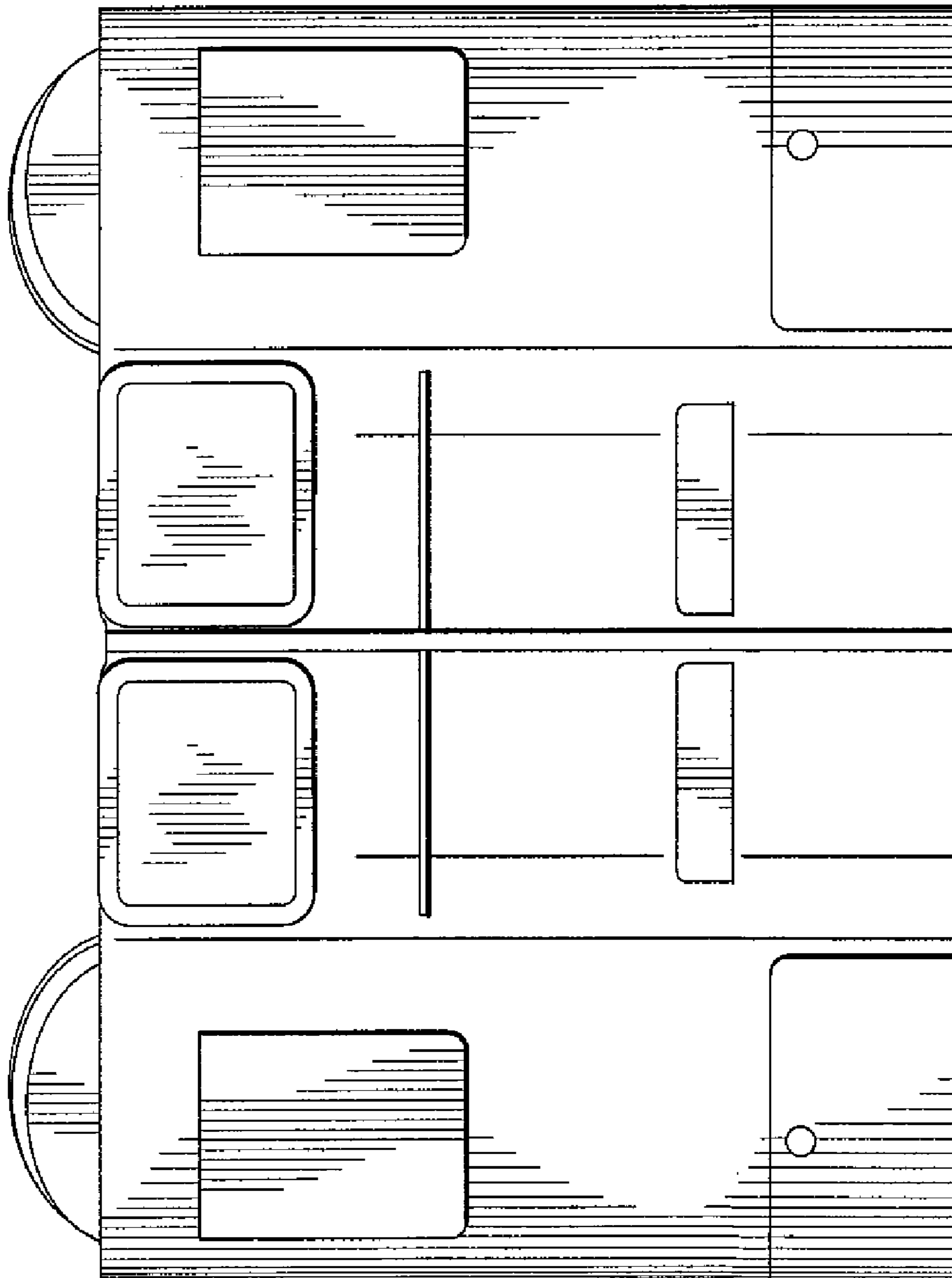

Fig. 3

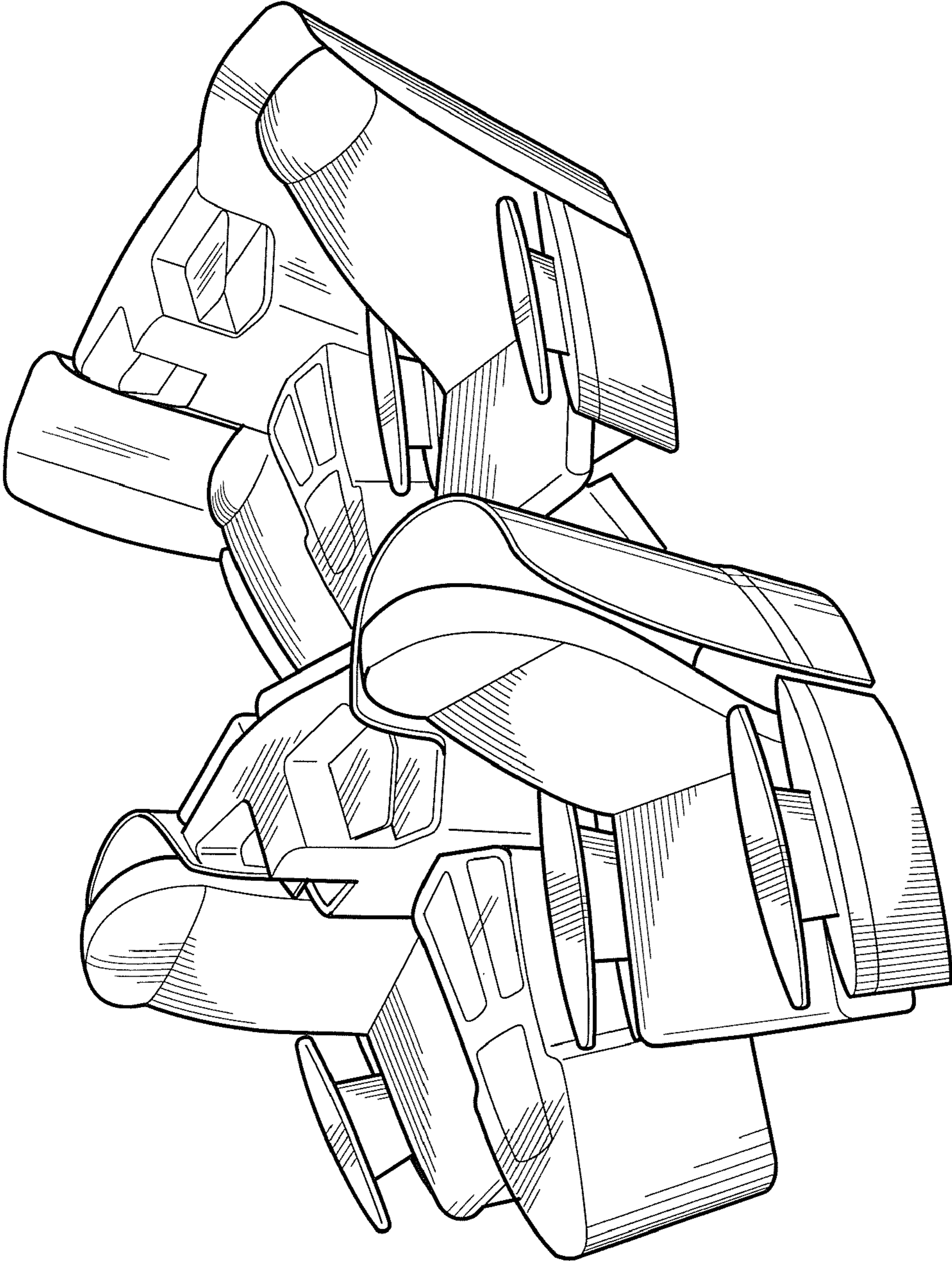

Fig. 4

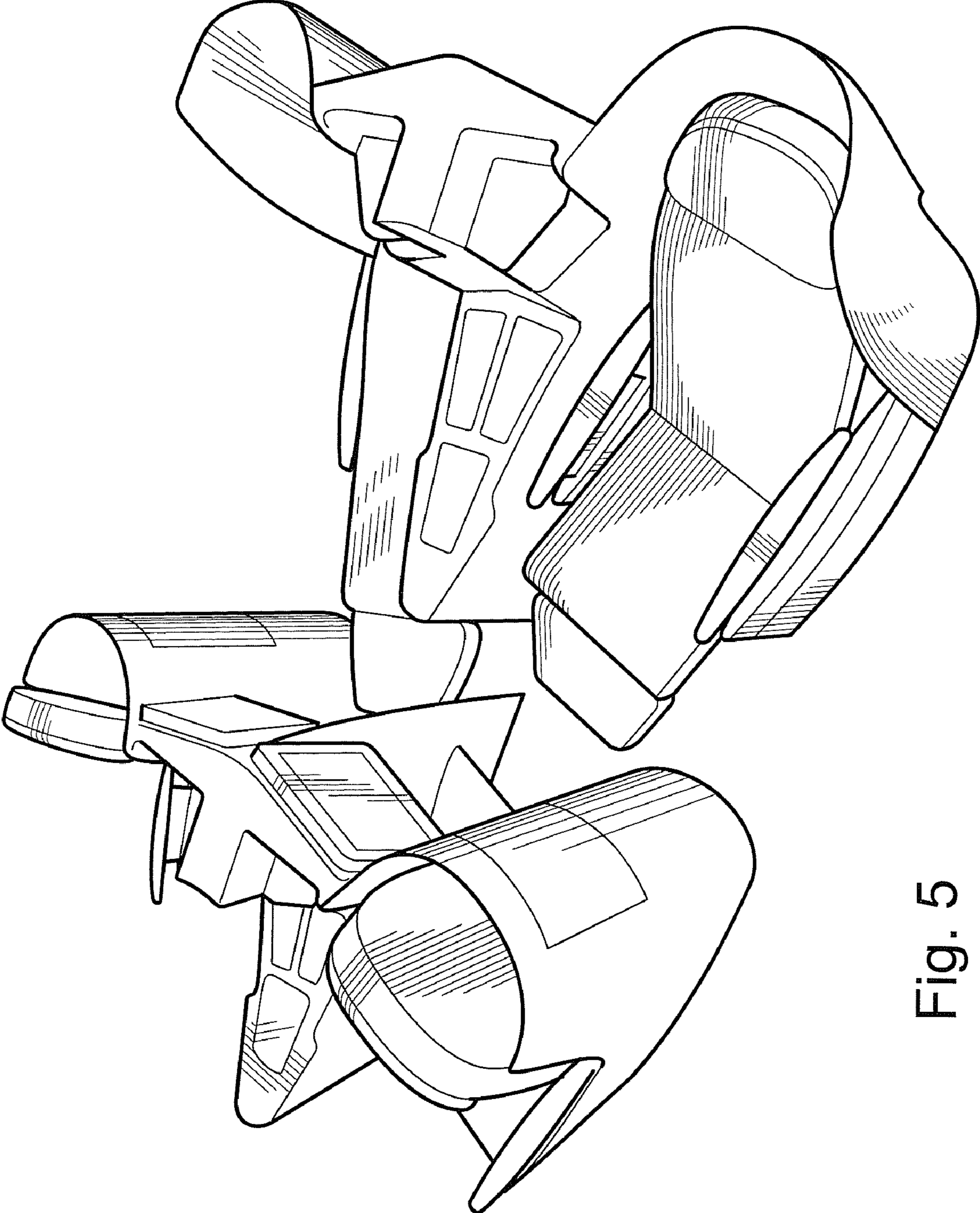

Fig. 5

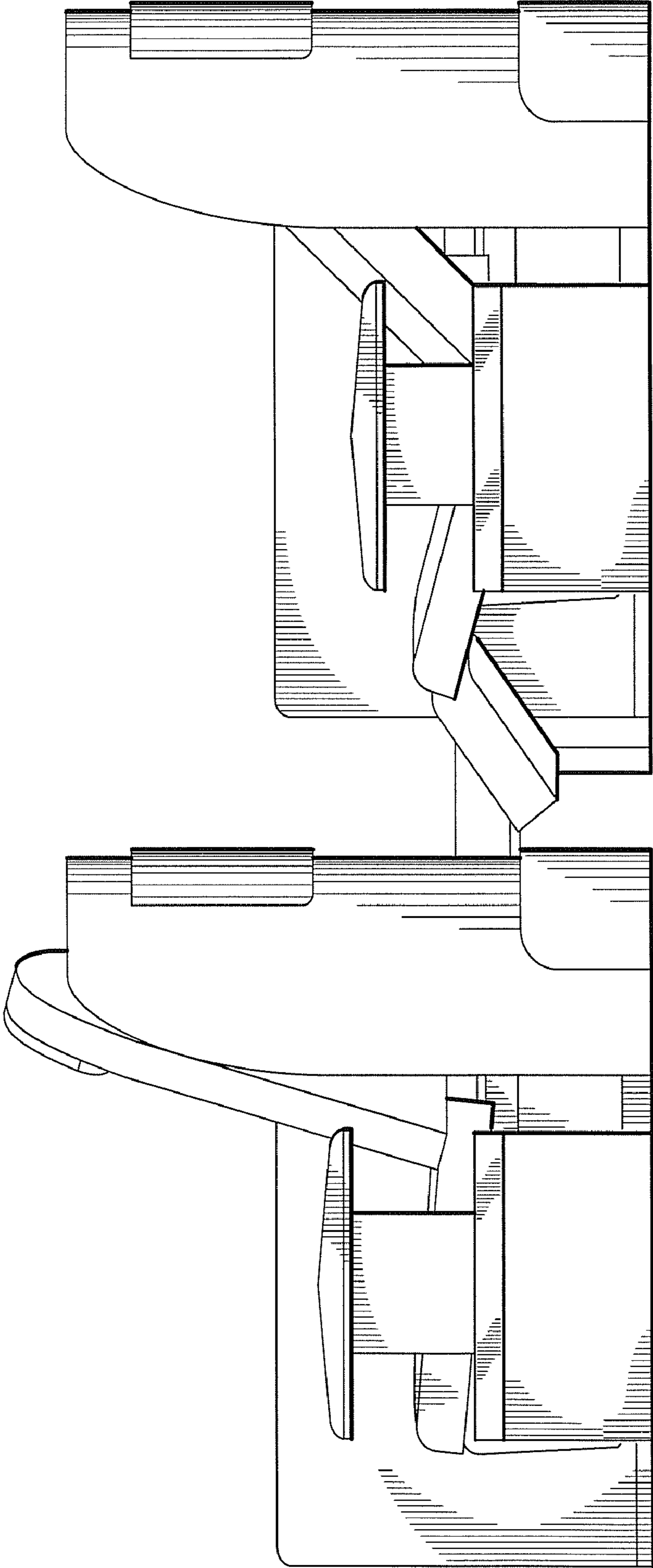

Fig. 6