



US00D610967S

(12) **United States Design Patent**
Ohara et al.

(10) **Patent No.:** **US D610,967 S**
(45) **Date of Patent:** **** *Mar. 2, 2010**

(54) **TIRE FOR AUTOMOBILE**

JP D1309420 8/2007

(75) Inventors: **Nariko Ohara**, 538-18,
Ayameikeminami 7-chome, Nara-shi,
Nara (JP) 631-0033; **Kuniaki**
Takamatsu, 55, Takamatsu,
Kaminoyama-shi (JP) 999-3243

* cited by examiner

Primary Examiner—Caron Veynar
Assistant Examiner—George D Kirschbaum

(73) Assignees: **Nariko Ohara**, Nara-Shi, Nara (JP);
Kuniaki Takamatsu, Kaminoyama-Shi,
Yamagata (JP); **Yoshiaki Ito**,
Nagoya-Shi, Aichi (JP); **Hideaki**
Kikuchi, Osaka-Shi, Osaka (JP)

(57) **CLAIM**

The ornamental design for a tire for automobile, as shown and described.

(*) Notice: This patent is subject to a terminal disclaimer.

DESCRIPTION

(**) Term: **14 Years**

The patent or application file contains at least one drawing executed in color. Copies of this patent or patent application publication with color drawing(s) will be provided by the office upon request and payment of the necessary fee.

(21) Appl. No.: **29/290,106**

FIG. 1 is a front left perspective view of a tire for automobile showing my new design;

(22) Filed: **Oct. 22, 2007**

FIG. 2 is a front view thereof, a rear view being a mirror image thereof; and,

(51) **LOC (9) Cl.** **12-15**

(52) **U.S. Cl.** **D12/579**

(58) **Field of Classification Search** D12/533-567;
152/209.1, 209.8, 209.12, 209.18, 209.25
See application file for complete search history.

FIG. 3 is right side view thereof, a left side view being the same.

The top view and the bottom view are the same as the front view.

(56) **References Cited**

U.S. PATENT DOCUMENTS

2,340,258 A * 1/1944 Brunner 152/209.12
3,674,076 A * 7/1972 Dailey, Jr. 152/209.18
D429,480 S * 8/2000 Bonko D12/500

FOREIGN PATENT DOCUMENTS

JP D1309046 8/2007

1 Claim, 3 Drawing Sheets
(2 of 3 Drawing Sheet(s) Filed in Color)

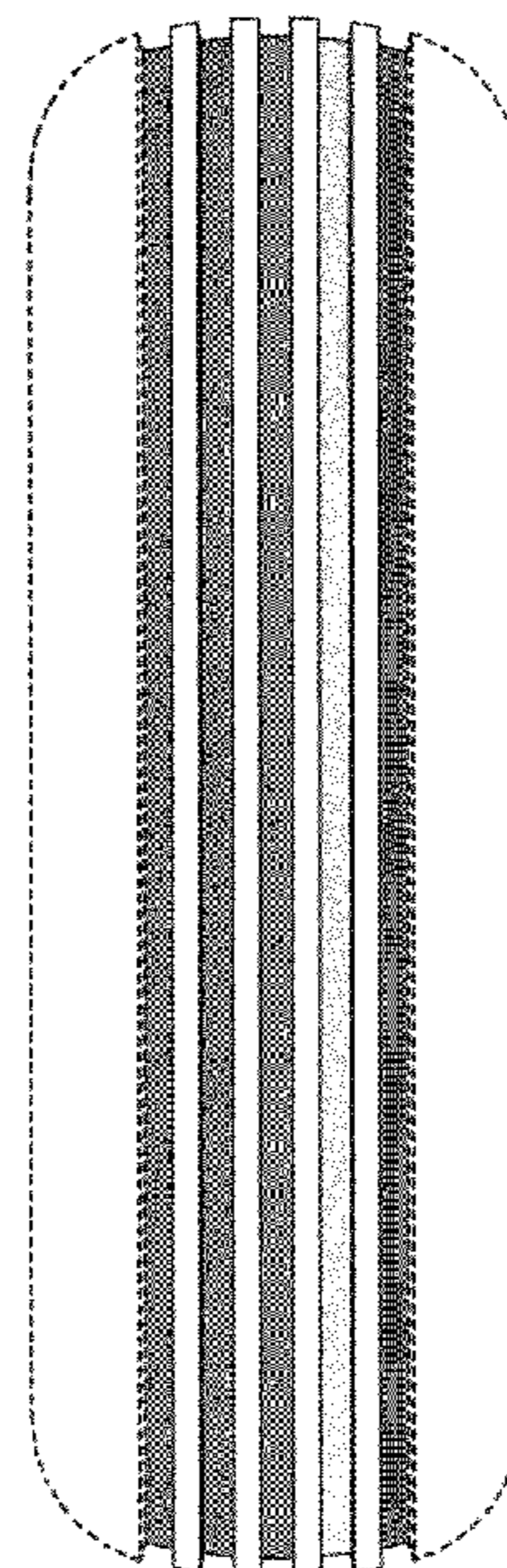
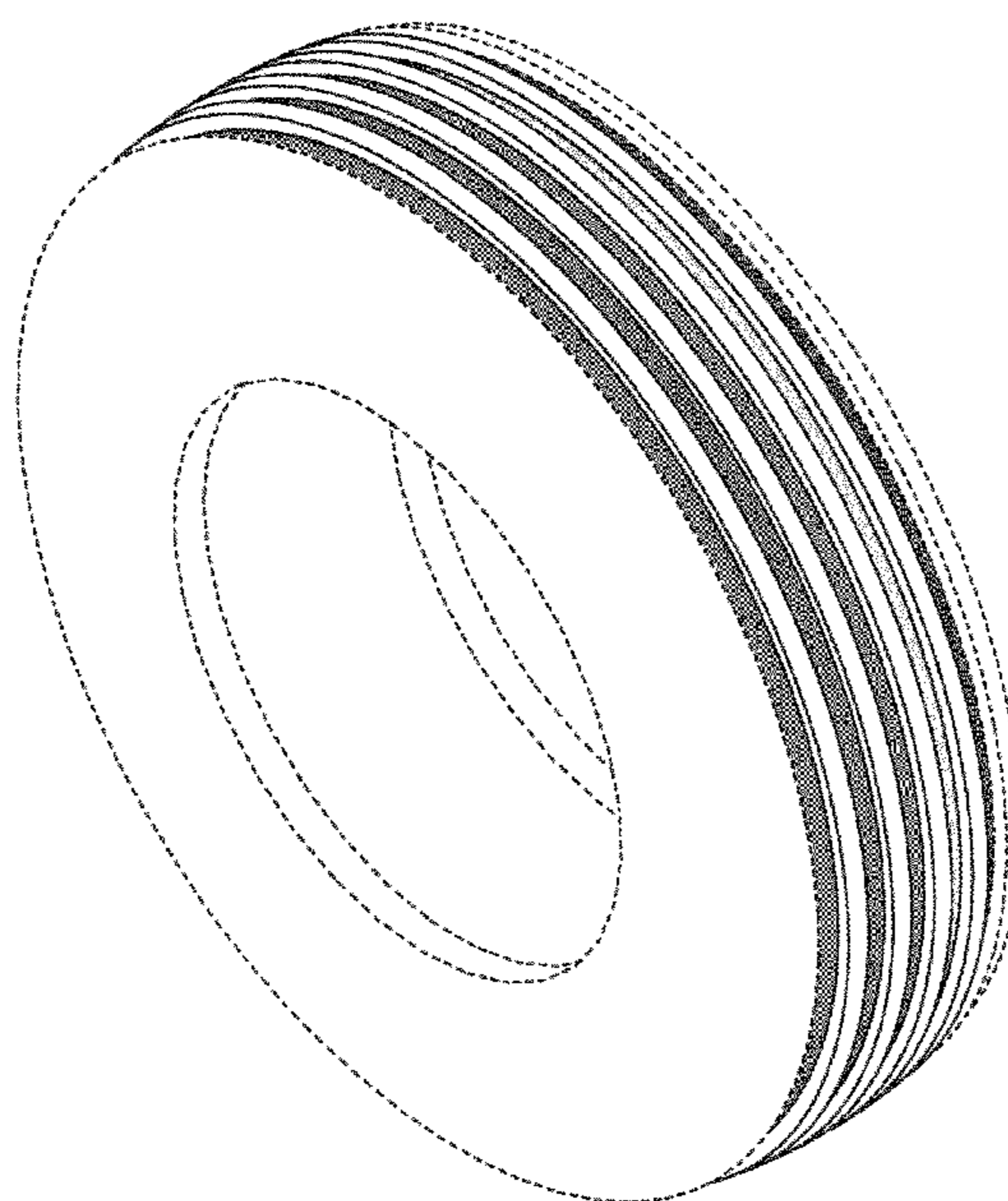

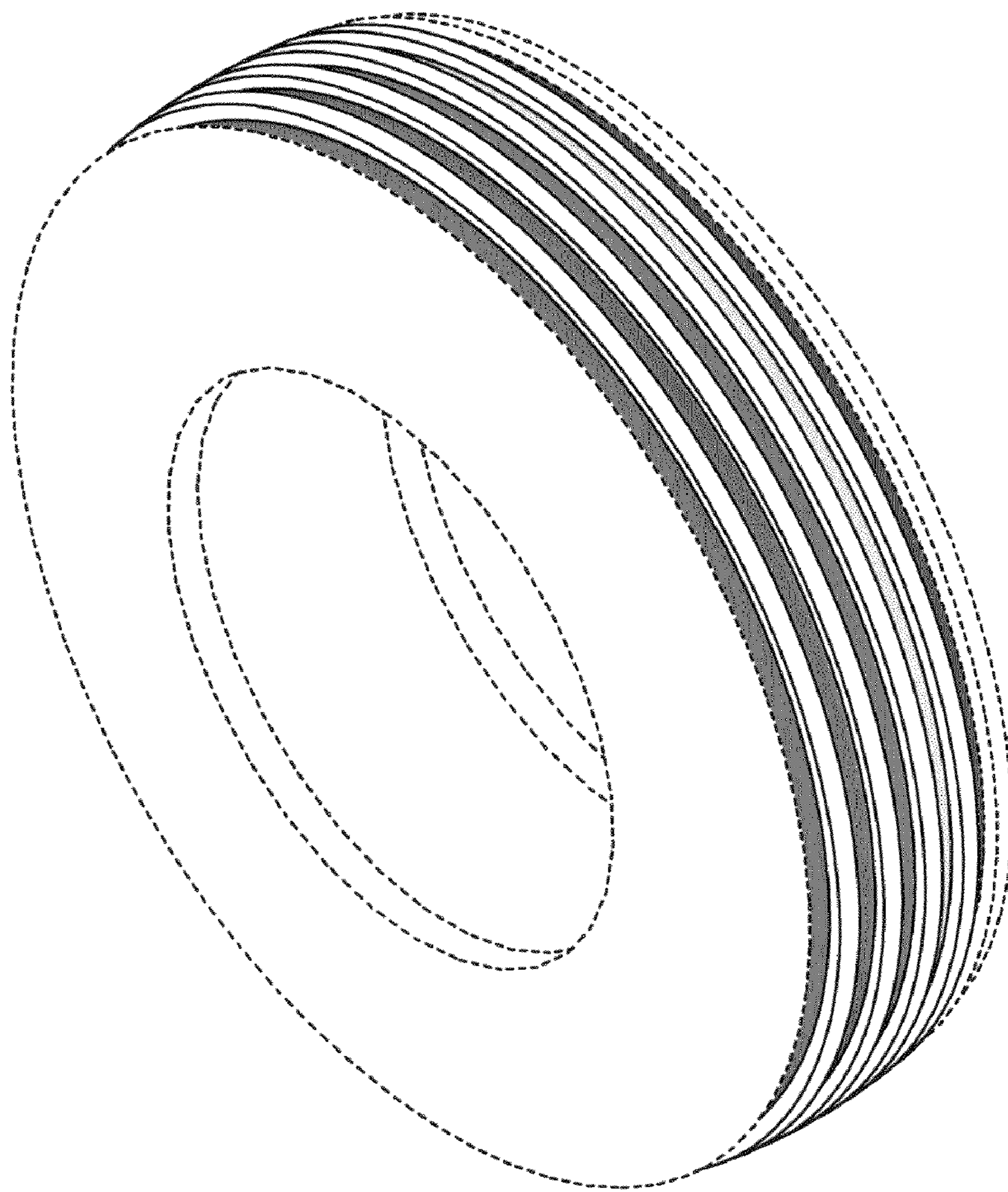
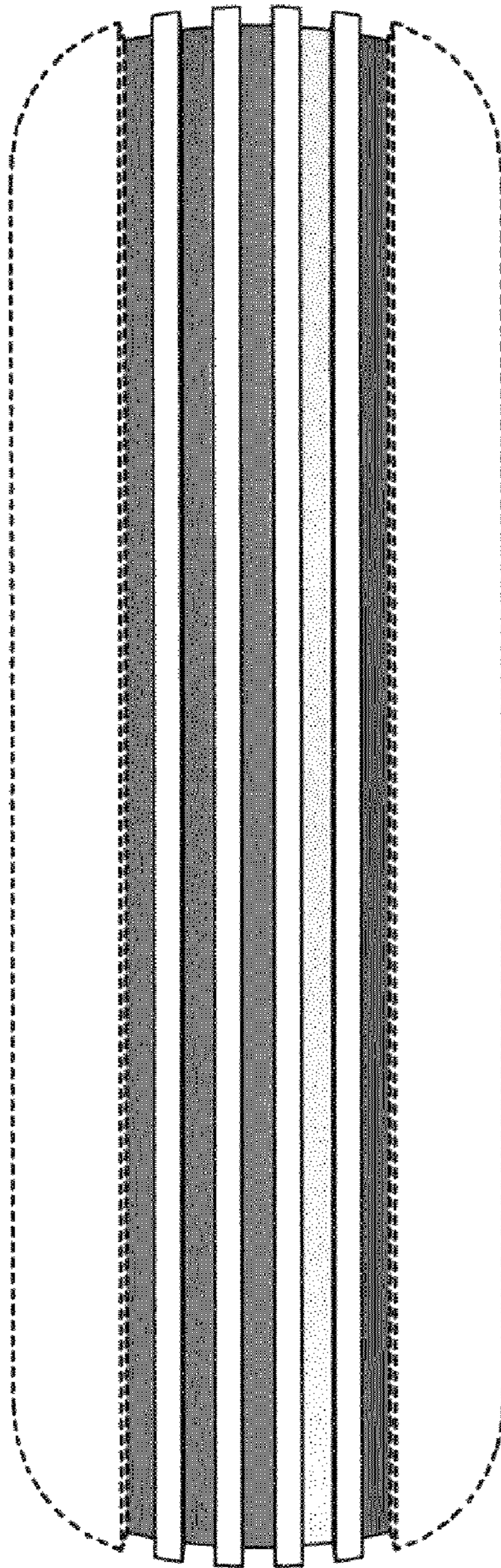

FIG. 1



F I G . 2

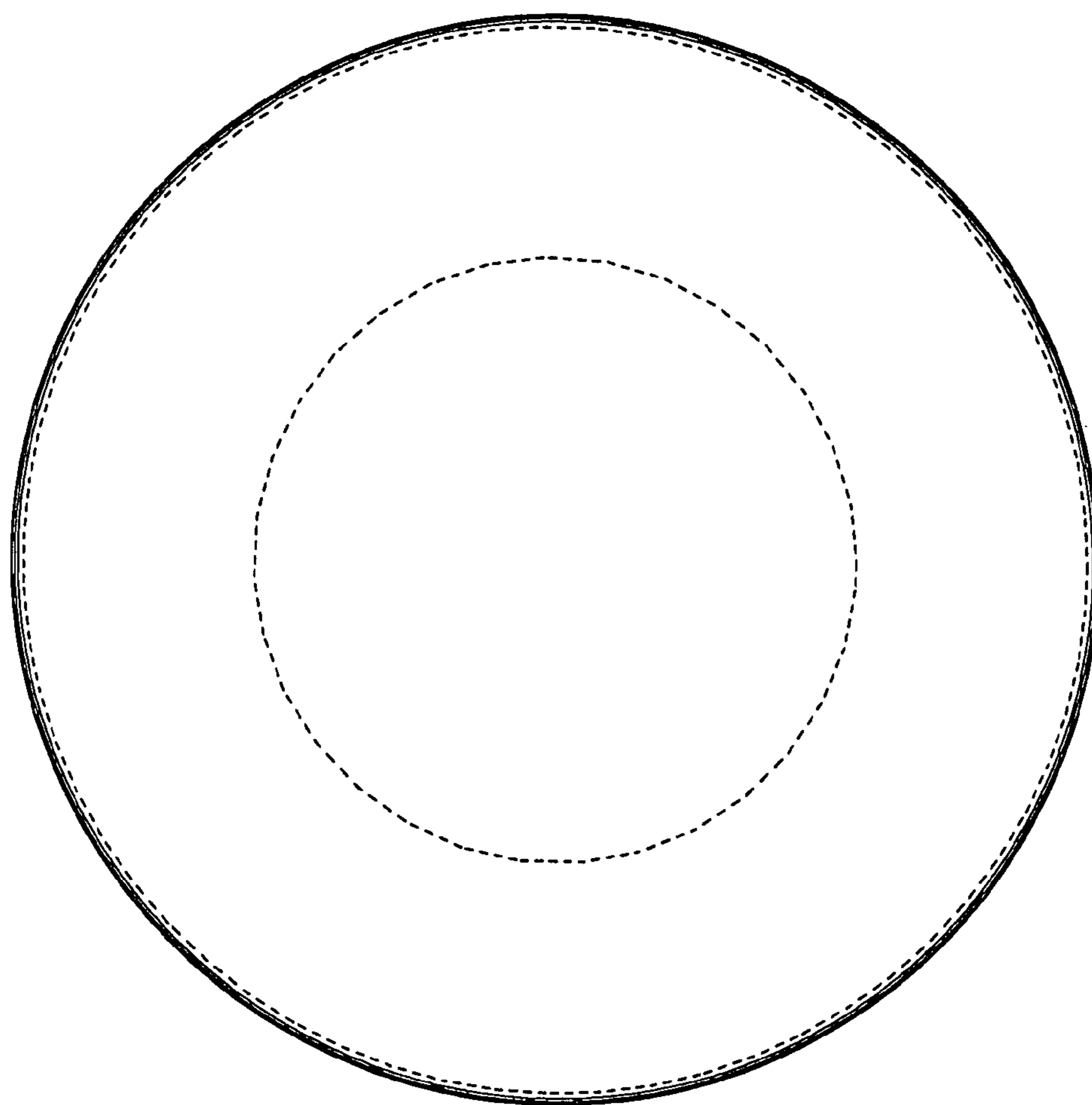

FIG. 3