



US00D610615S

(12) **United States Design Patent**  
**Li**

(10) **Patent No.:** **US D610,615 S**

(45) **Date of Patent:** **\*\* Feb. 23, 2010**

(54) **PEN**

(75) Inventor: **Bin Li, Ningbo (CN)**

(73) Assignee: **Beifa Group Co., Ltd., Ningbo (CN)**

(\*\*) Term: **14 Years**

(21) Appl. No.: **29/333,931**

(22) Filed: **Mar. 17, 2009**

(30) **Foreign Application Priority Data**

Oct. 10, 2008 (CN) ..... 2008 3 0146726

(51) **LOC (9) Cl.** ..... **19-06**

(52) **U.S. Cl.** ..... **D19/48**

(58) **Field of Classification Search** ..... D19/35,  
D19/36, 41, 42, 43, 44, 45, 46, 47, 48, 49,  
D19/50, 51, 54, 55, 56, 57; 24/11 F, 11 P,  
24/11 R; 401/6, 52, 99, 100, 104, 105, 106,  
401/107, 108, 109, 192, 195, 243, 244, 245,  
401/246, 247

See application file for complete search history.

(56) **References Cited**

**U.S. PATENT DOCUMENTS**

- D81,435 S \* 6/1930 Coby ..... D19/46
- D120,137 S \* 4/1940 Most ..... D19/48
- D138,501 S \* 8/1944 Beckstrom ..... D19/48
- D138,502 S \* 8/1944 Beckstrom ..... D19/48
- D144,459 S \* 4/1946 Iwanowicz ..... D19/42
- 2,608,953 A \* 9/1952 Kollsman ..... 401/35
- D188,972 S \* 10/1960 Young ..... D19/49
- D189,170 S \* 11/1960 Lovejoy ..... D19/55
- 4,352,579 A \* 10/1982 Yi ..... 401/19
- D303,991 S \* 10/1989 Murphy ..... D19/48
- D304,601 S \* 11/1989 Alskog ..... D19/49
- D325,045 S \* 3/1992 Katami ..... D19/49

- D342,090 S \* 12/1993 Anavil et al. .... D19/49
- 5,915,871 A \* 6/1999 Kobayashi et al. .... 401/213
- D430,606 S \* 9/2000 Veillon ..... D19/48
- D463,822 S \* 10/2002 Keda ..... D19/48
- 6,488,430 B1 \* 12/2002 Jimenez ..... 401/195
- D479,856 S \* 9/2003 Hui ..... D19/43
- D503,742 S 4/2005 Mori
- D508,077 S 8/2005 Bhavnani
- D513,766 S \* 1/2006 Cetera ..... D19/36
- D522,579 S 6/2006 Sim
- D537,879 S 3/2007 O'Hern
- D544,034 S 6/2007 Qiu
- D559,315 S 1/2008 Qiu
- D576,675 S 9/2008 Kent
- D577,064 S 9/2008 Brigg
- D580,493 S 11/2008 Fei
- D591,348 S \* 4/2009 Yu et al. .... D19/49

\* cited by examiner

*Primary Examiner*—Elizabeth A Albert

*Assistant Examiner*—Karen E Eldridge Powers

(74) *Attorney, Agent, or Firm*—Christensen O'Connor Johnson Kindness PLLC

(57) **CLAIM**

The ornamental design for a pen, as shown and described.

**DESCRIPTION**

FIG. 1 is an upper front right perspective view of a pen showing my new design;

FIG. 2 is a left side elevation view of the pen shown in FIG. 1;

FIG. 3 is an enlarged top plan view thereof;

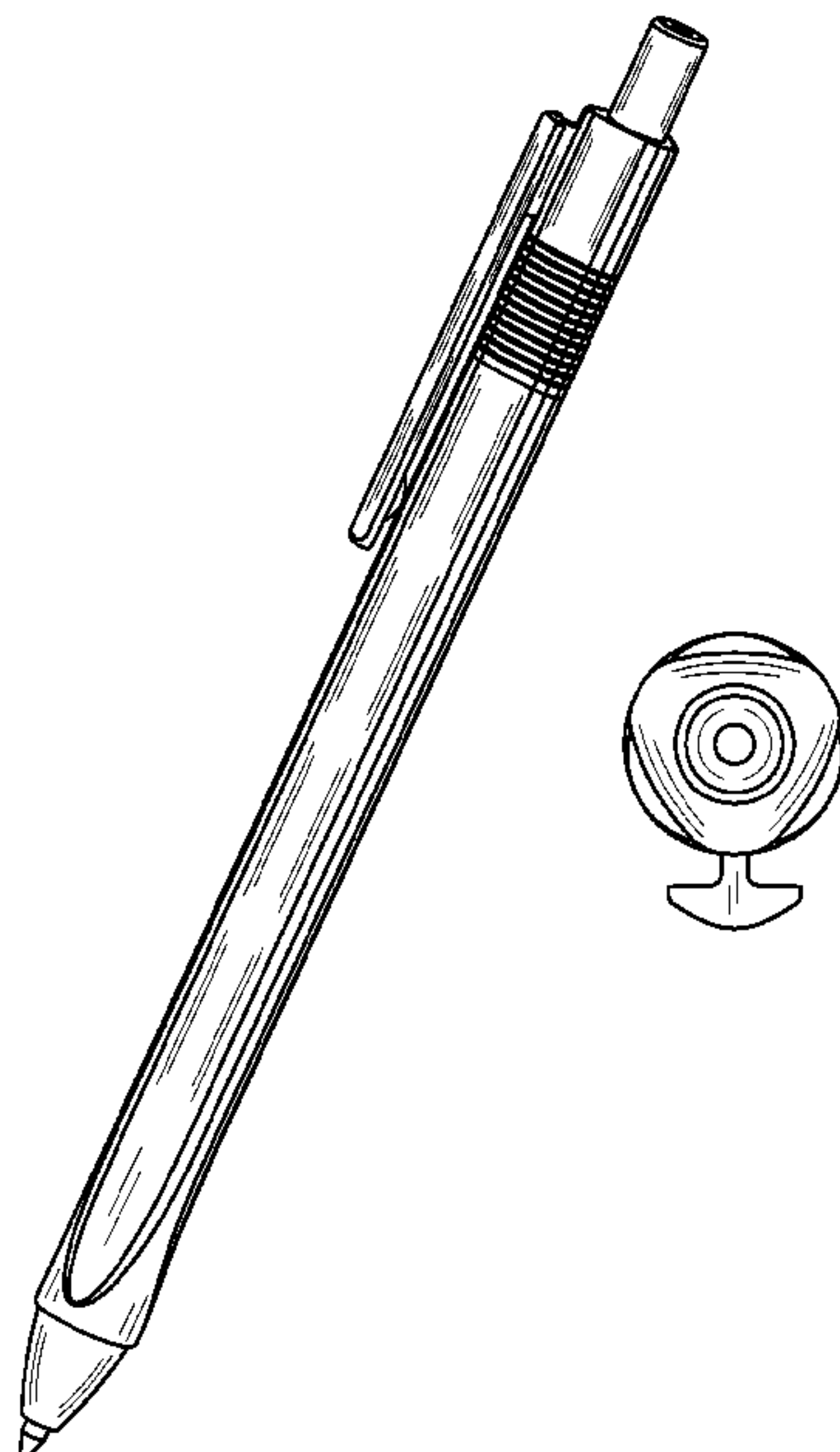
FIG. 4 is a front elevation view thereof;

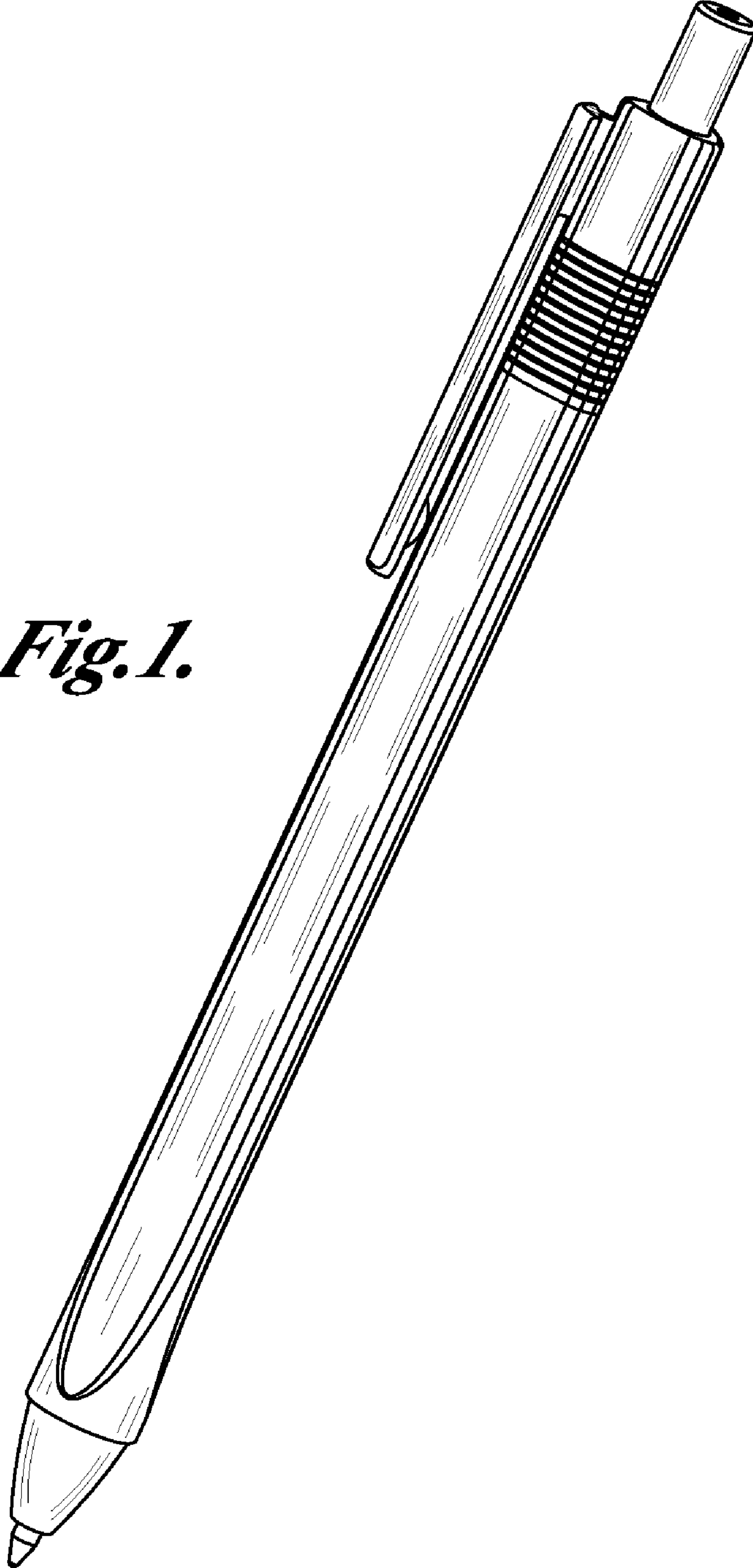
FIG. 5 is a right side elevation view thereof;

FIG. 6 is an enlarged bottom plan view thereof; and,

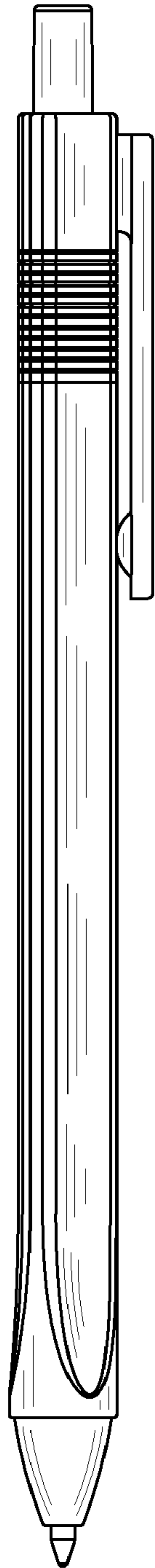
FIG. 7 is a rear elevation view thereof.

**1 Claim, 3 Drawing Sheets**

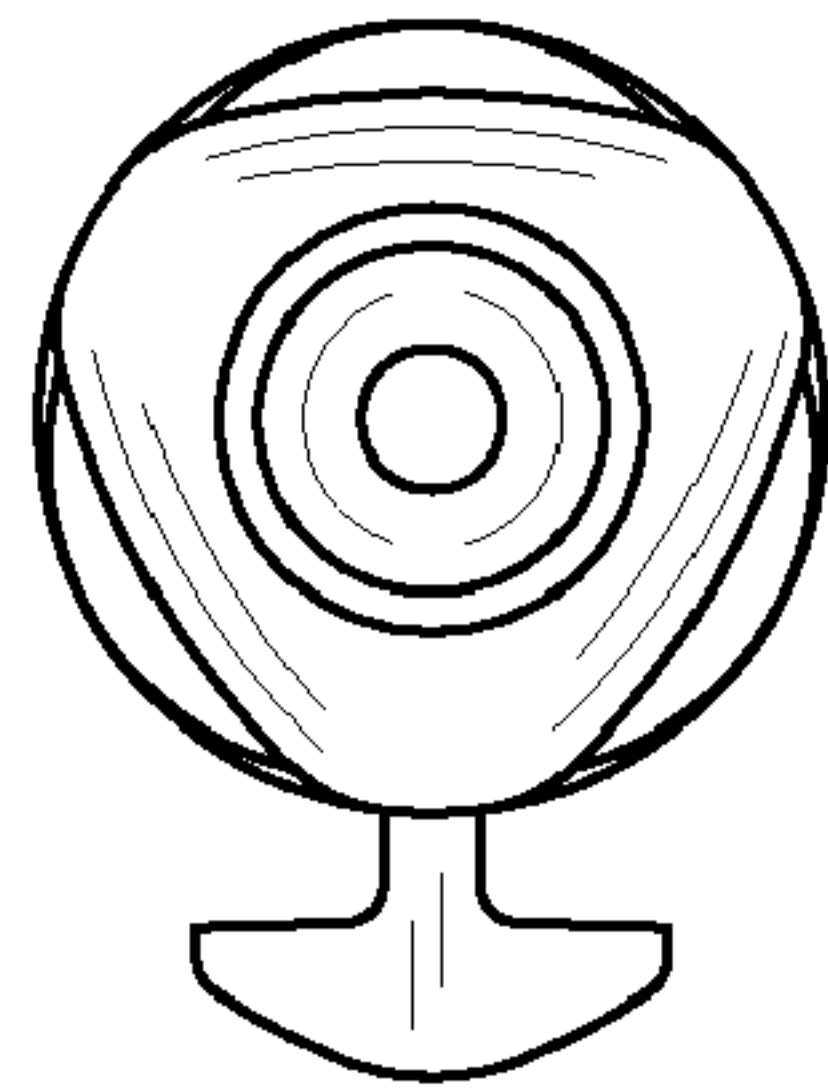




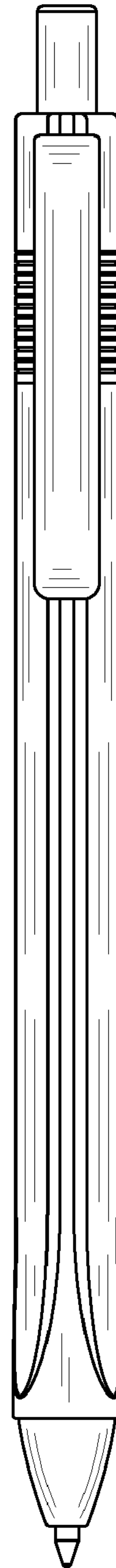
*Fig. 1.*



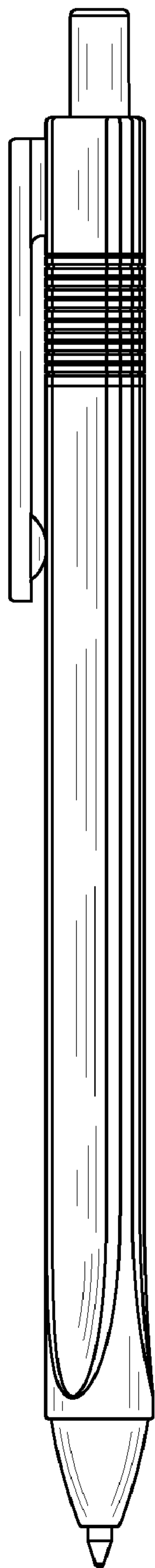
*Fig. 2.*



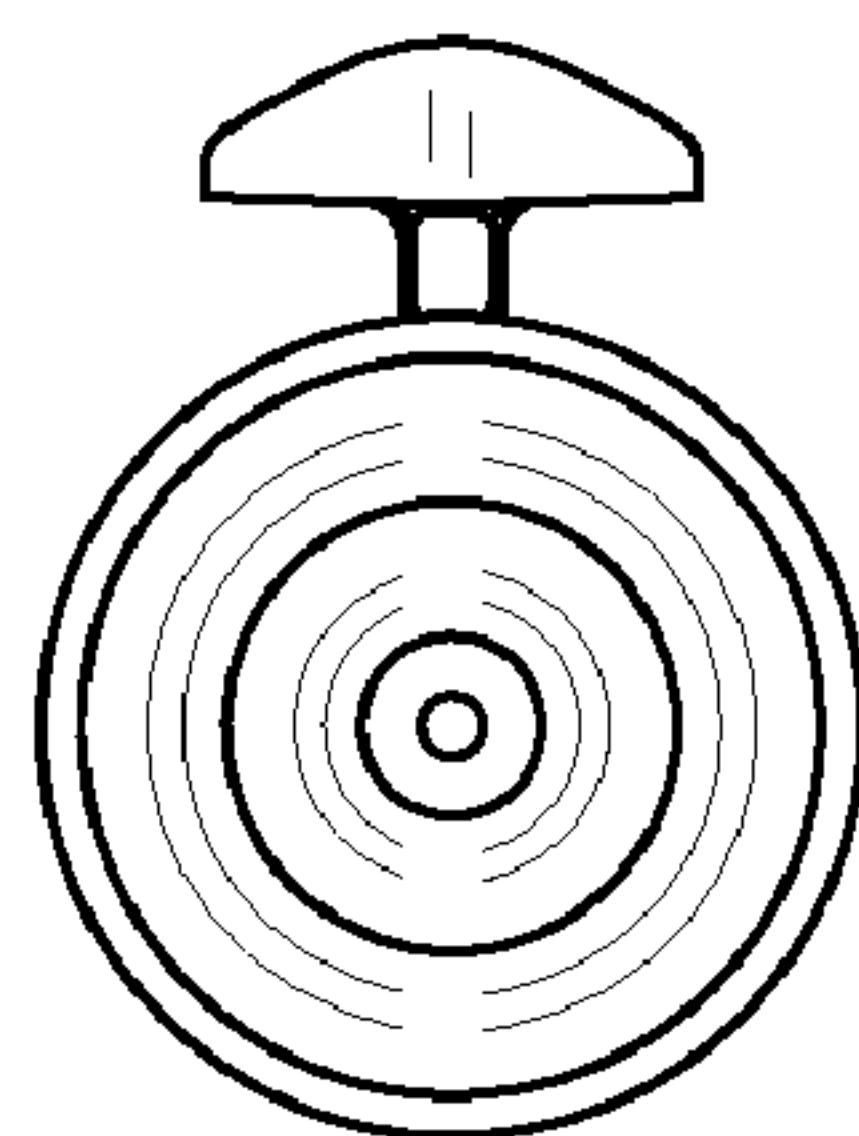
*Fig. 3.*



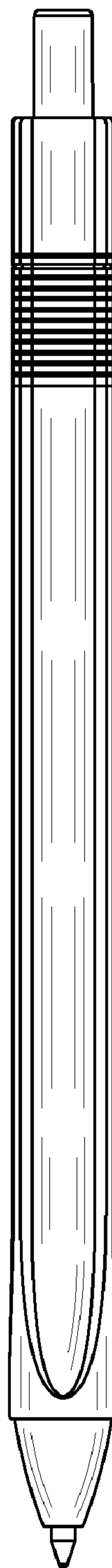
*Fig. 4.*



*Fig. 5.*



*Fig. 6.*



*Fig. 7.*