



US00D610534S

(12) **United States Design Patent**  
**Kuroishi**

(10) **Patent No.:** **US D610,534 S**

(45) **Date of Patent:** **\*\* Feb. 23, 2010**

(54) **SIDEWALL PORTION OF AN AUTOMOBILE TIRE**

(75) Inventor: **Kazuya Kuroishi**, Tokyo (JP)

(73) Assignee: **Bridgestone Corporation**, Tokyo (JP)

(\*\*) Term: **14 Years**

(21) Appl. No.: **29/337,953**

(22) Filed: **Jun. 2, 2009**

(30) **Foreign Application Priority Data**

Apr. 6, 2009 (JP) ..... 2009-007919  
Apr. 6, 2009 (JP) ..... 2009-007920

(51) **LOC (9) Cl.** ..... **12-15**

(52) **U.S. Cl.** ..... **D12/605**

(58) **Field of Classification Search** ..... D12/500-501,  
D12/544, 579, 600, 605, 604, 900-901; 152/523-524,  
152/DIG. 12, 555; D7/588, 396.4-396.5  
See application file for complete search history.

(56) **References Cited**

U.S. PATENT DOCUMENTS

D198,519 S \* 6/1964 McLellan ..... D12/605  
D203,317 S \* 12/1965 Busch ..... D12/605  
D206,986 S \* 2/1967 Makris ..... D12/605  
D373,751 S \* 9/1996 Barrese ..... D12/605  
D412,476 S \* 8/1999 Clementz et al. .... D12/605  
D577,330 S 9/2008 Miyasaka

FOREIGN PATENT DOCUMENTS

JP 1332663 S 6/2008

\* cited by examiner

*Primary Examiner*—Stacia Cadmus

(74) *Attorney, Agent, or Firm*—Sughrue Mion, PLLC

(57) **CLAIM**

The ornamental design for a sidewall portion of an automobile tire, as shown and described.

**DESCRIPTION**

FIG. 1 is a front view of the sidewall portion of an automobile tire according to a first embodiment of the present invention;

FIG. 2 is a perspective view thereof;

FIG. 3 is a left side view thereof;

FIG. 4 is a fragmentary enlarged view showing the details of the sidewall portion defined by the cross-section surrounded by lines A—A, B—B, C—C and D—D in FIG. 1 thereof;

FIG. 5 is a fragmentary enlarged view showing the details of the sidewall surrounded by the line E—E, F—F, G—G and H—H in FIG. 2 thereof;

FIG. 6 is a front view of the sidewall portion of an automobile tire according to a second embodiment of the present invention;

FIG. 7 is a perspective view thereof;

FIG. 8 is a left side view thereof;

FIG. 9 is a fragmentary enlarged view showing the details of the sidewall portion defined by the cross-section surrounded by lines A—A, B—B, C—C and D—D in FIG. 6 thereof; and,

FIG. 10 is a fragmentary enlarged view showing the details of the sidewall surrounded by the line E—E, F—F, G—G and H—H in FIG. 7 thereof.

Broken lines are used to show environmental structure only, and form no part of the claimed design.

**1 Claim, 10 Drawing Sheets**

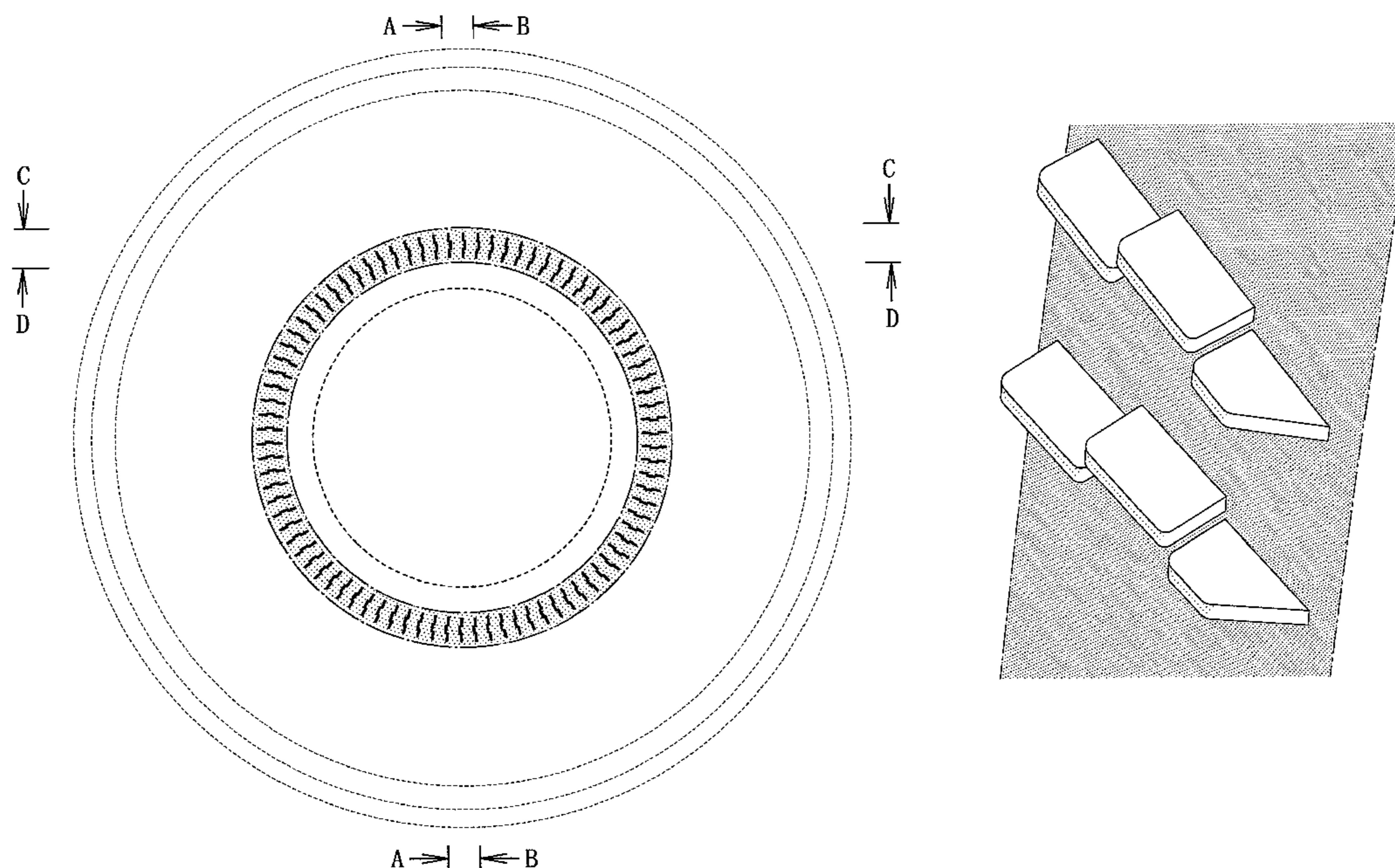

Figure 1

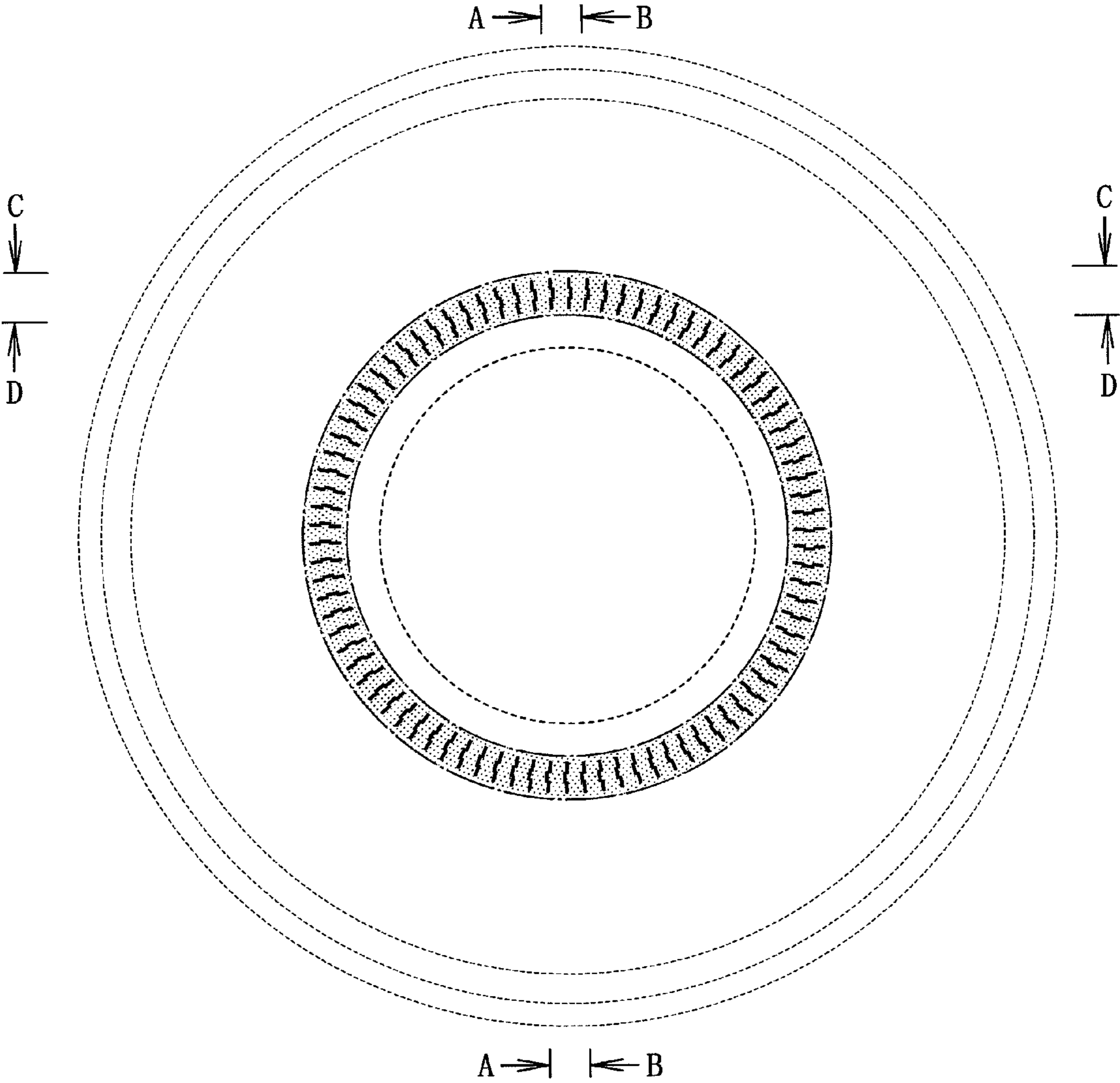

Figure 2

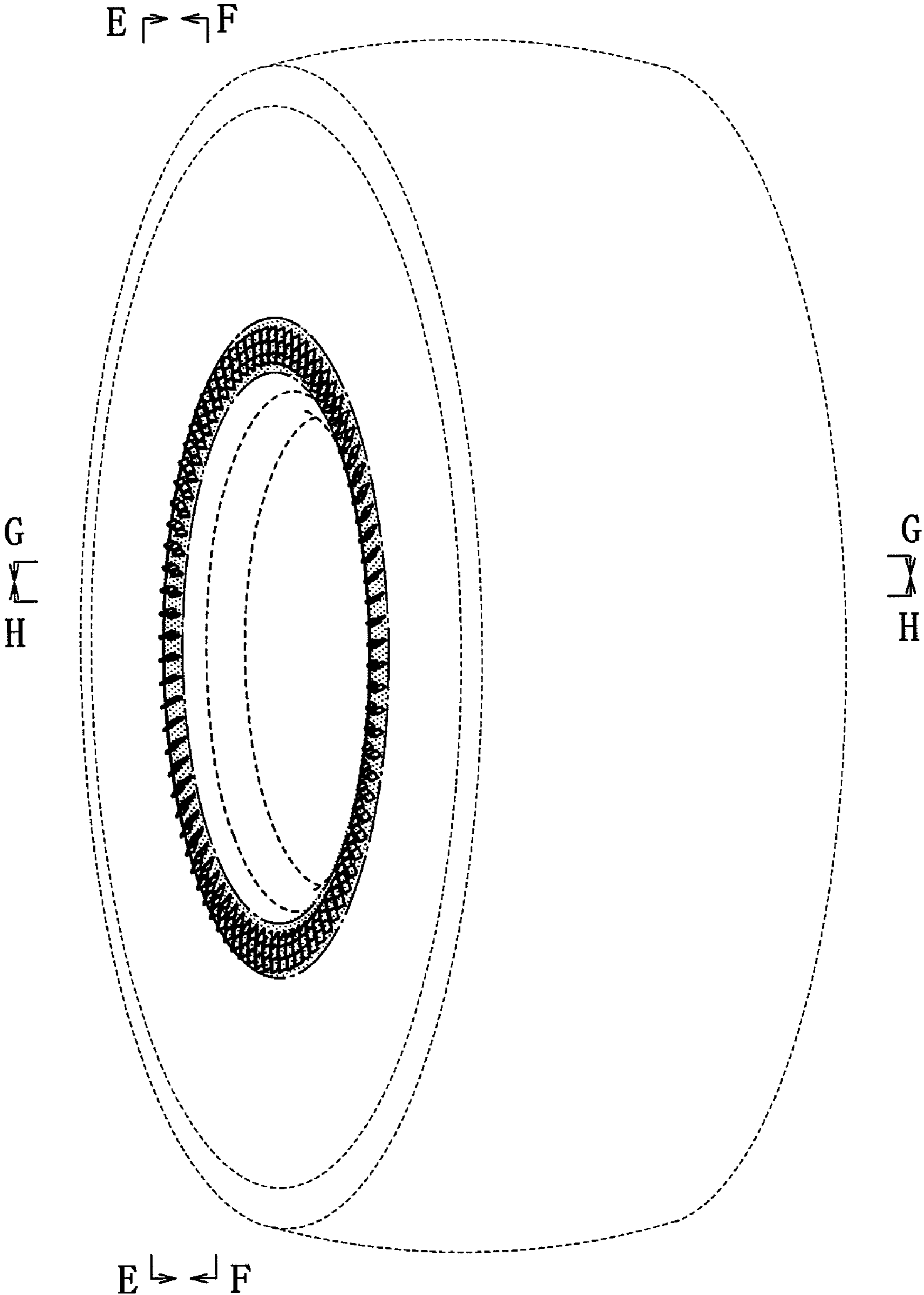

Figure 3

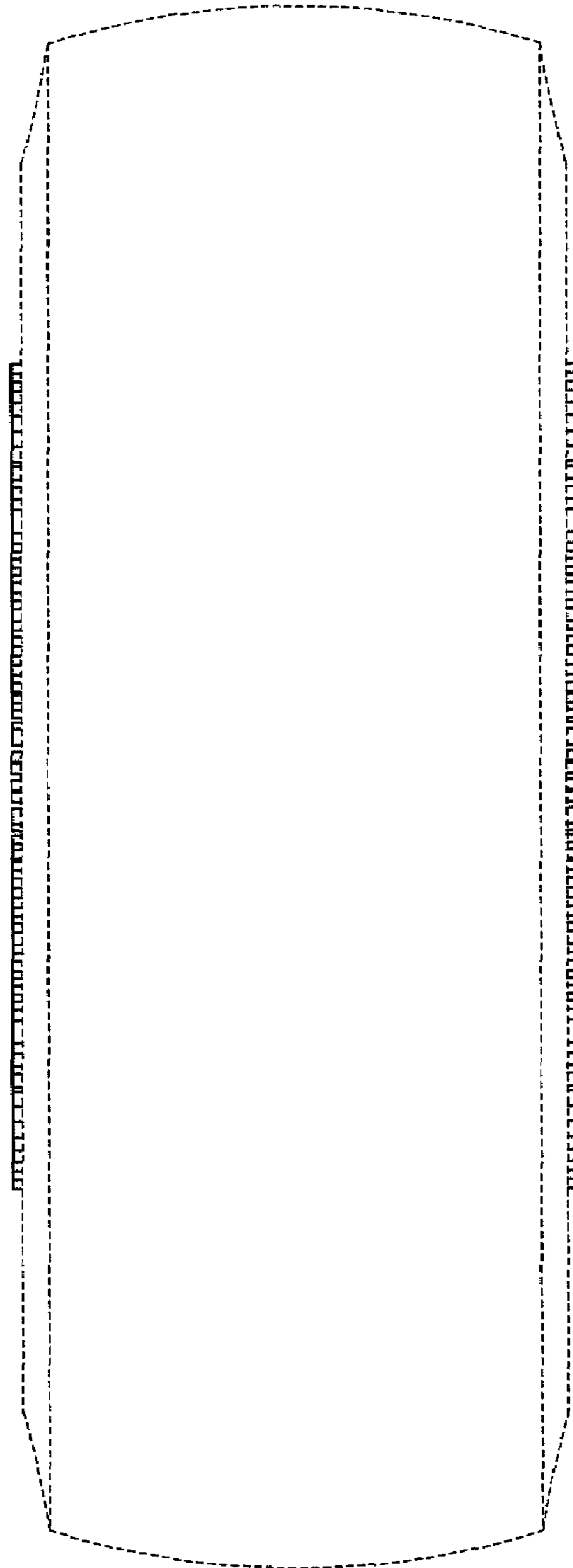
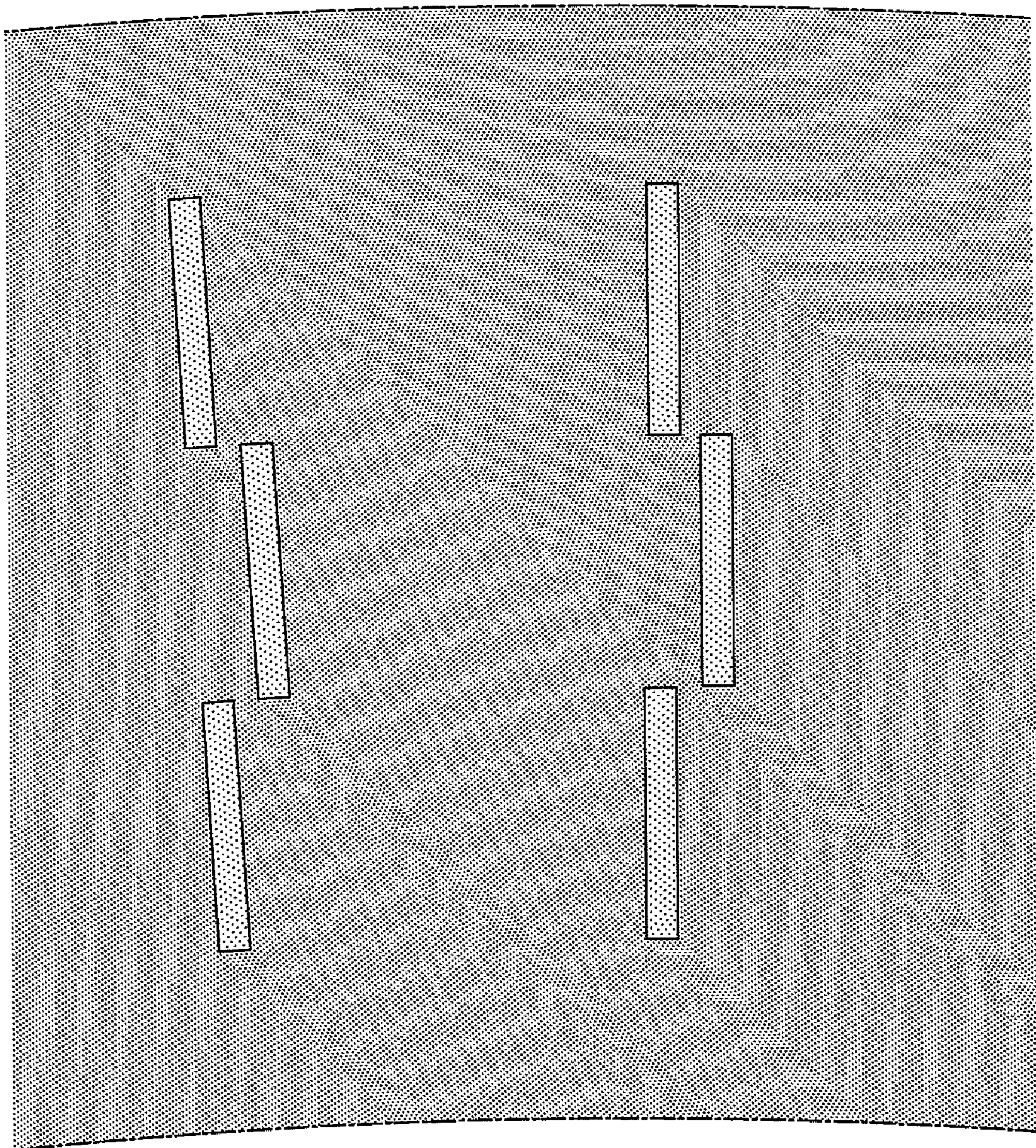

Figure 4



# Figure 5

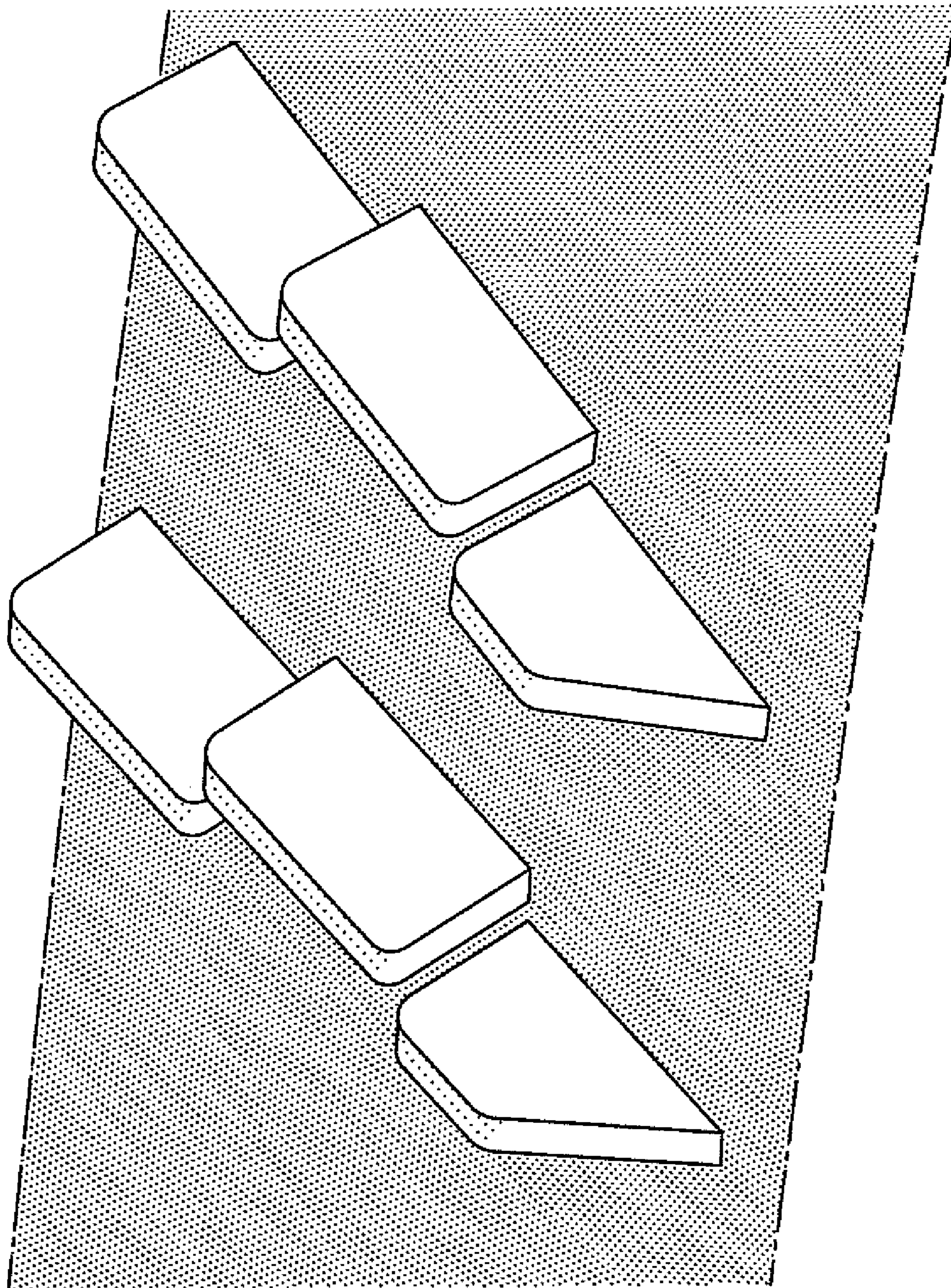

Figure 6

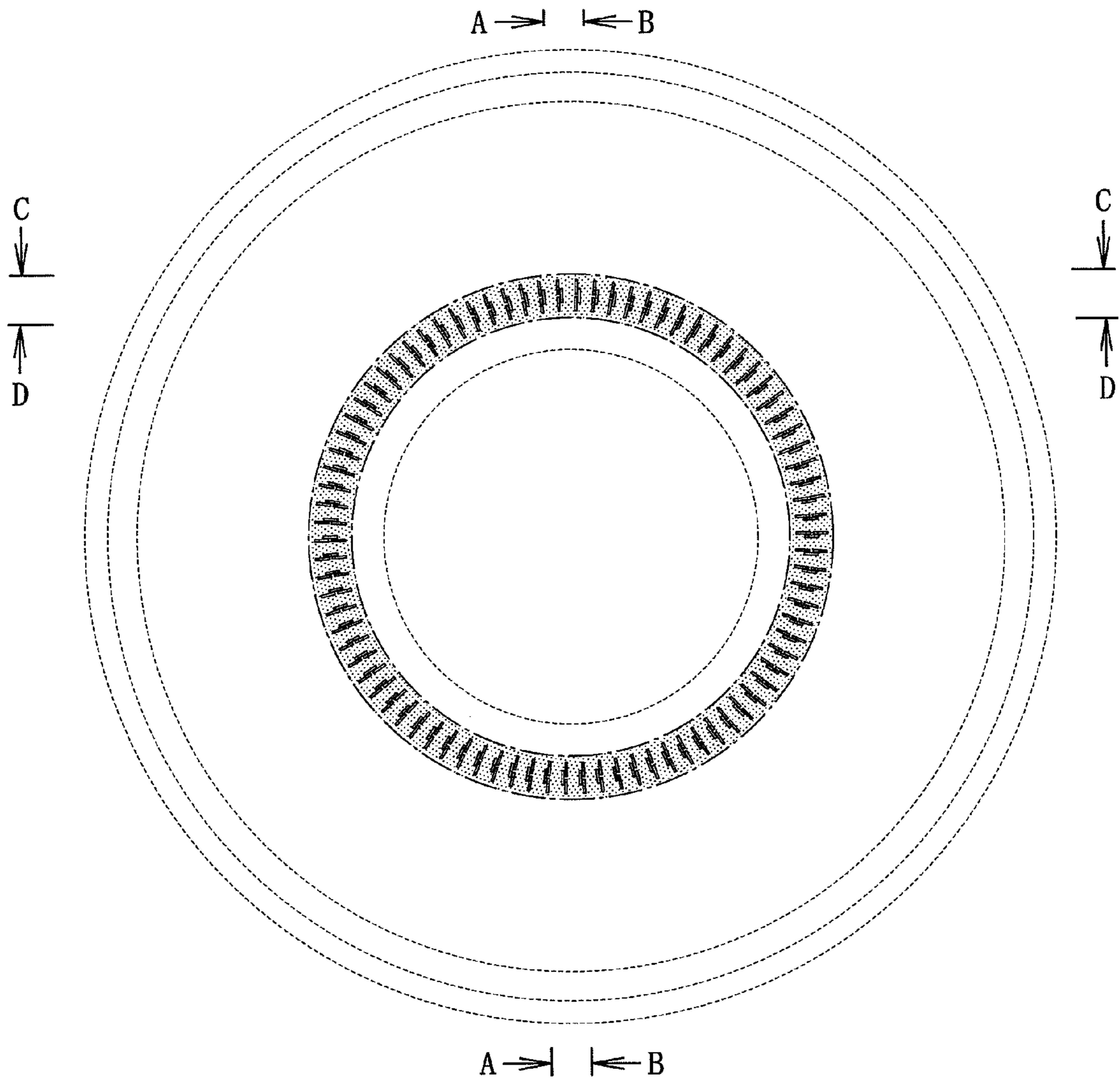

Figure 7

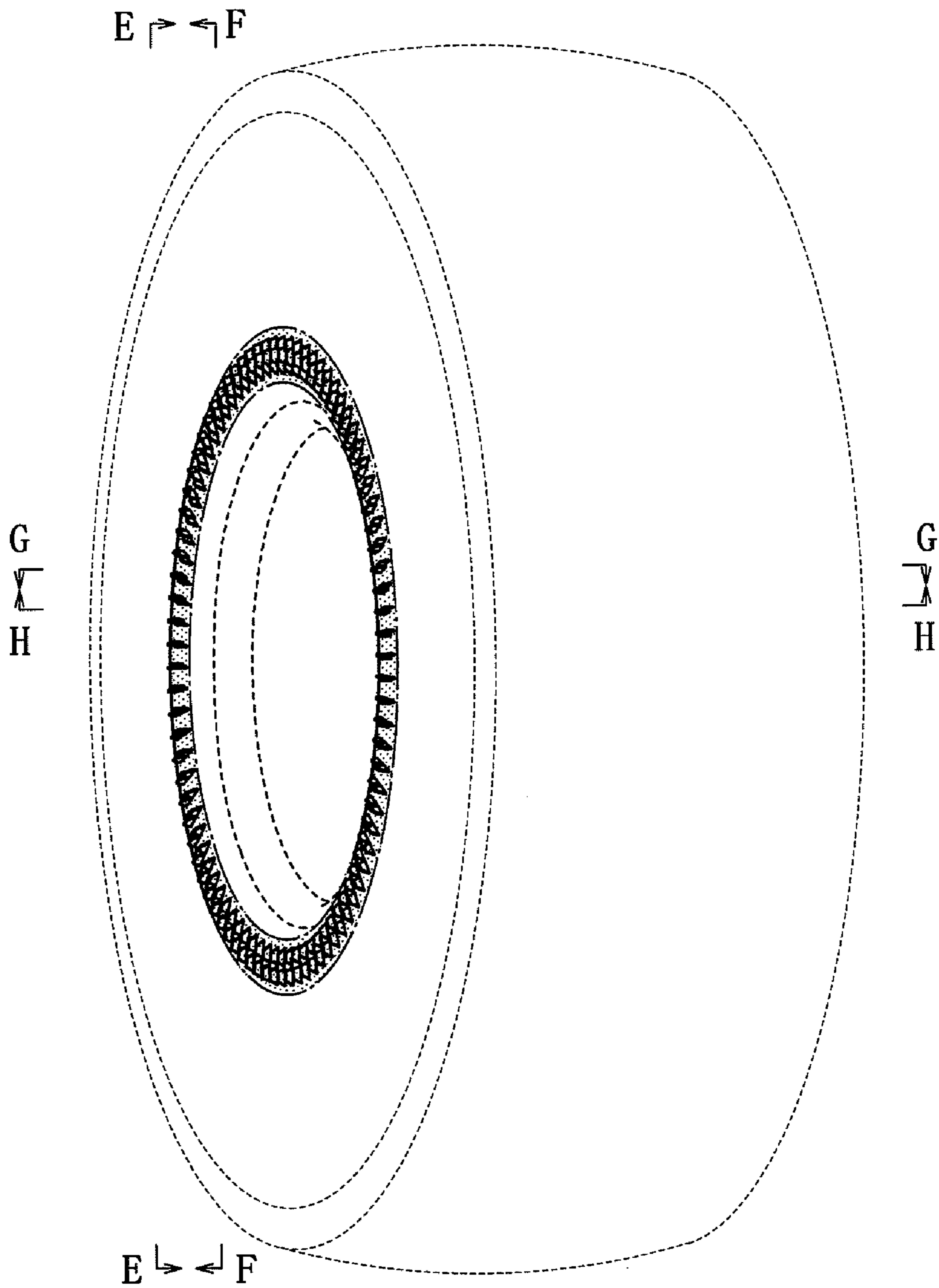



Figure 8

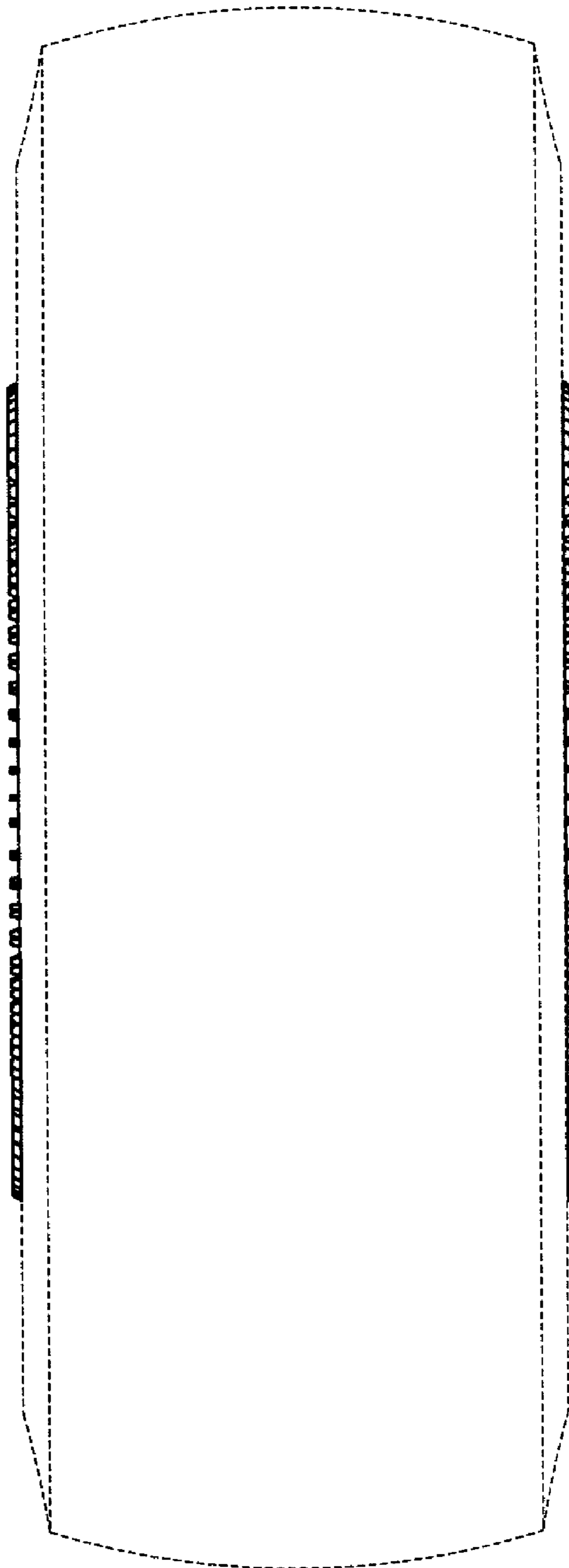
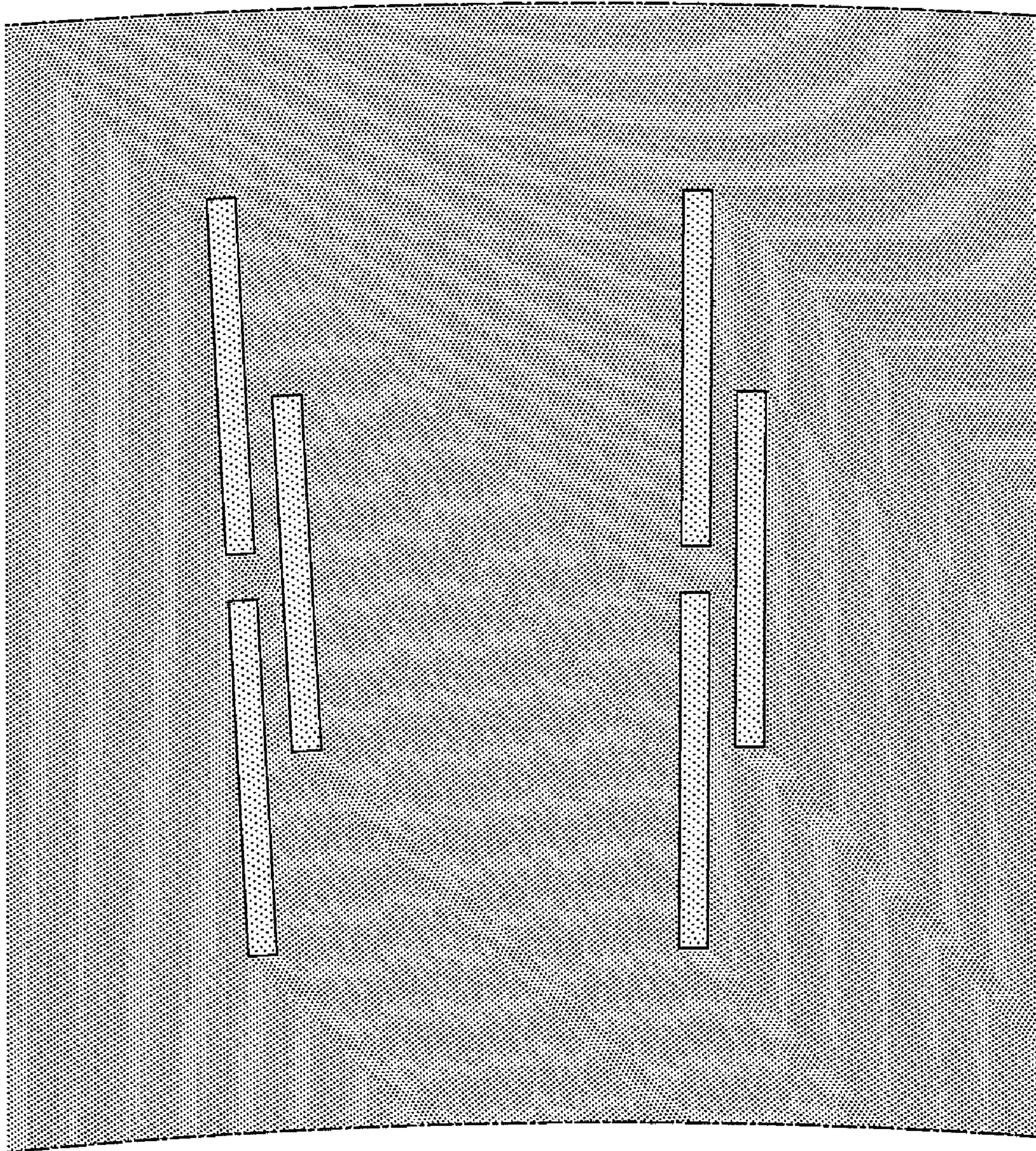

Figure 9



# Figure 10

