



US00D610511S

(12) **United States Design Patent**
Dubanowski et al.

(10) **Patent No.:** **US D610,511 S**

(45) **Date of Patent:** **** Feb. 23, 2010**

(54) **SET OF FRONT AND REAR FENDER FLARES**

(76) Inventors: **Michael K. Dubanowski**, 304 Churchill Ct., Sleepy Hollow, IL (US) 60118;
Glenn E. Bolt, 180 S. Melrose Ave., Elgin, IL (US) 60123

(**) Term: **14 Years**

(21) Appl. No.: **29/345,364**

(22) Filed: **Oct. 14, 2009**

(51) **LOC (9) Cl.** **12-08**

(52) **U.S. Cl.** **D12/181**

(58) **Field of Classification Search** D12/181,
D12/184, 196, 400, 190, 88; 280/848, 770,
280/727; 296/91, 180.1-180.5; 180/903
See application file for complete search history.

(56) **References Cited**

U.S. PATENT DOCUMENTS

D386,130 S *	11/1997	Nielsen, III	D12/106
D461,436 S *	8/2002	Stickles et al.	D12/190
D517,965 S *	3/2006	Metros et al.	D12/190
D546,253 S *	7/2007	Lee et al.	D12/184
D549,624 S *	8/2007	Jones	D12/184
D590,756 S *	4/2009	Williams et al.	D12/184

* cited by examiner

Primary Examiner—Caron Veynar
Assistant Examiner—Katrina A Kile

(74) *Attorney, Agent, or Firm*—QuickPatents, Inc.; Kevin Prince

(57) **CLAIM**

We claim the ornamental design for a set of front and rear fender flares, as shown and described.

DESCRIPTION

FIG. 1 is a perspective view of a set of front and rear fender flares, showing our new design;

FIG. 2 is a rear elevational view of a rear fender flare thereof;

FIG. 3 is a front elevational view thereof;

FIG. 4 is a left-side elevational view thereof;

FIG. 5 is a right-side elevational view thereof;

FIG. 6 is a top plan view thereof;

FIG. 7 is a bottom plan view thereof;

FIG. 8 is a rear elevational view of a front fender flare of the design;

FIG. 9 is a front elevational view thereof;

FIG. 10 is a left-side elevational view thereof;

FIG. 11 is a right-side elevational view thereof;

FIG. 12 is a top plan view thereof; and,

FIG. 13 is a bottom plan view thereof.

In the drawings, the broken lines in FIG. 1 show a vehicle and tires and form no part of the claimed design.

1 Claim, 5 Drawing Sheets

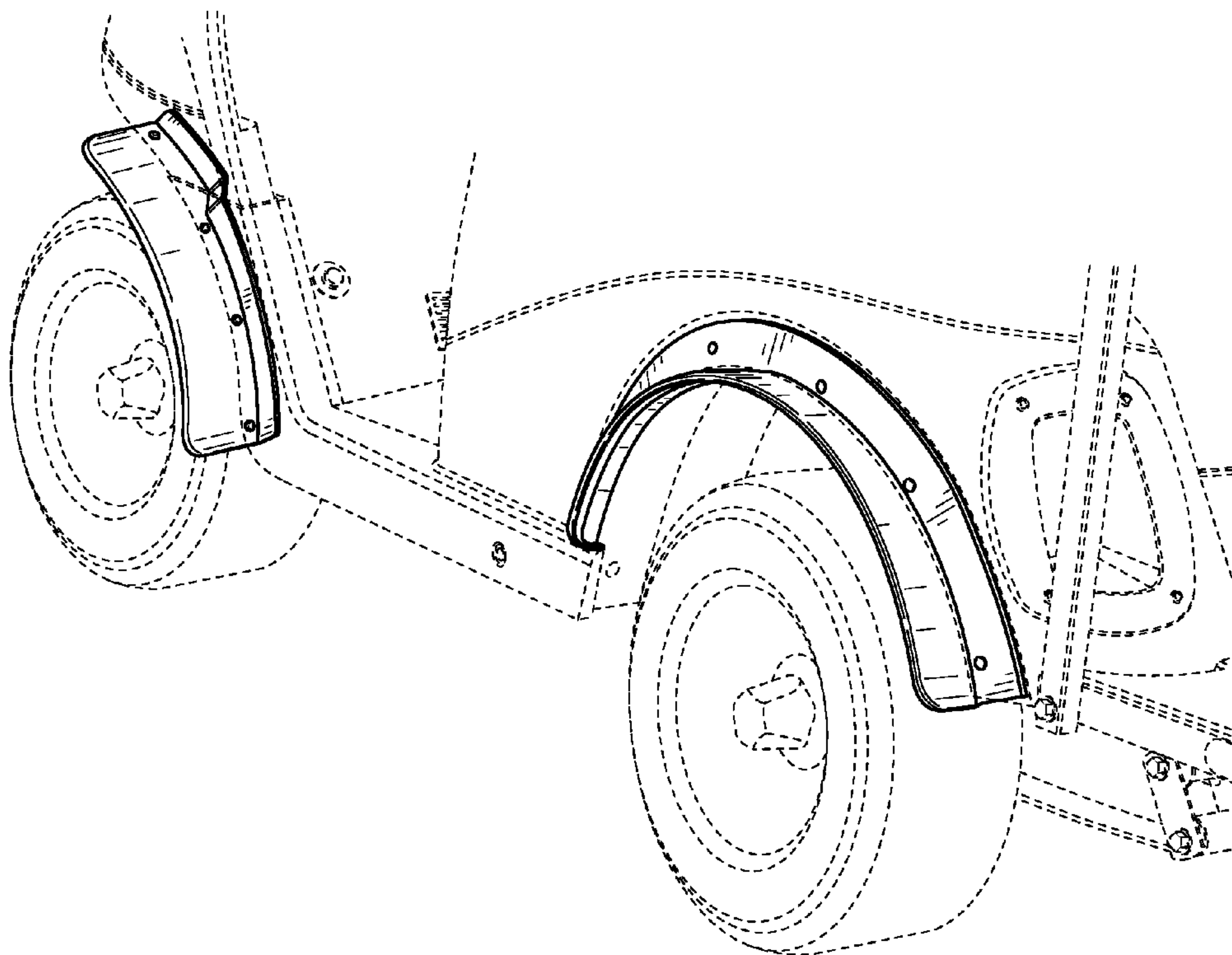

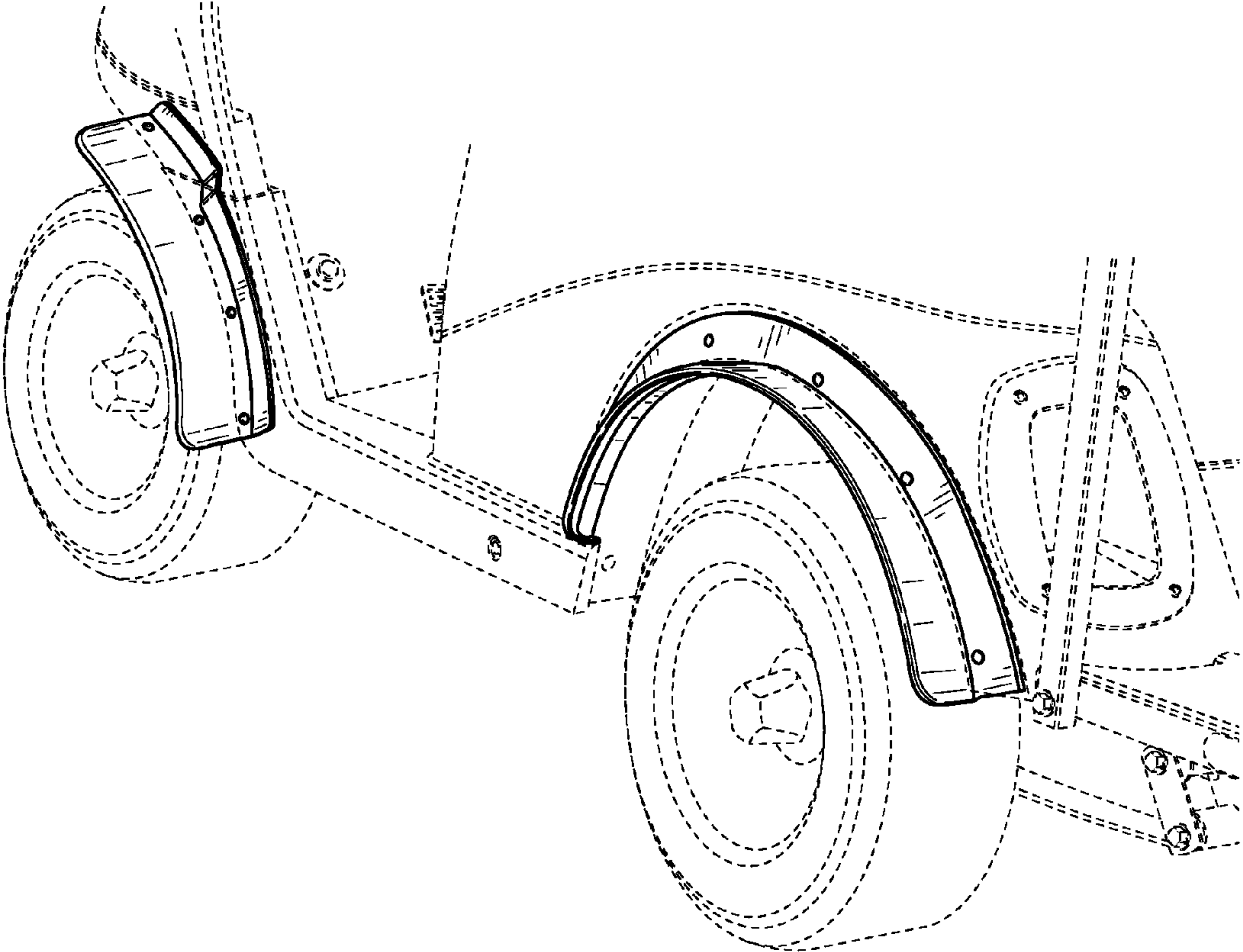

FIG. 1

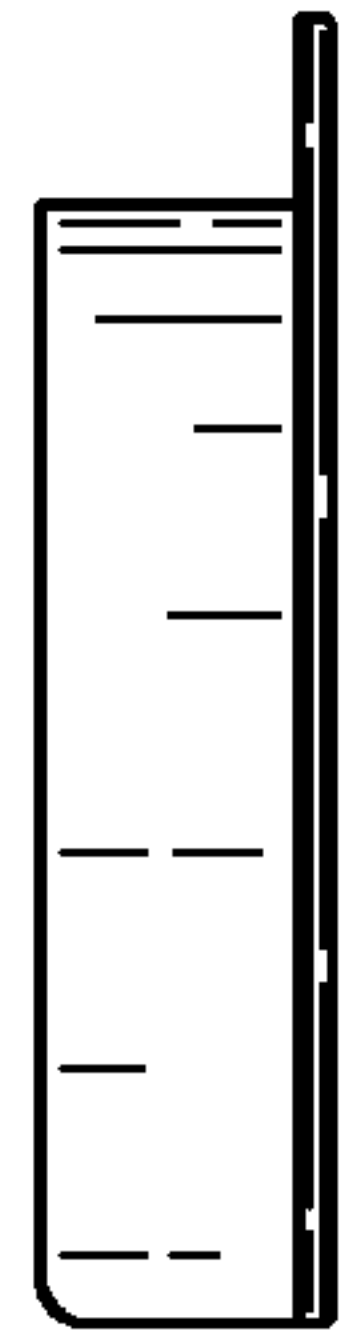

FIG. 2



FIG. 3

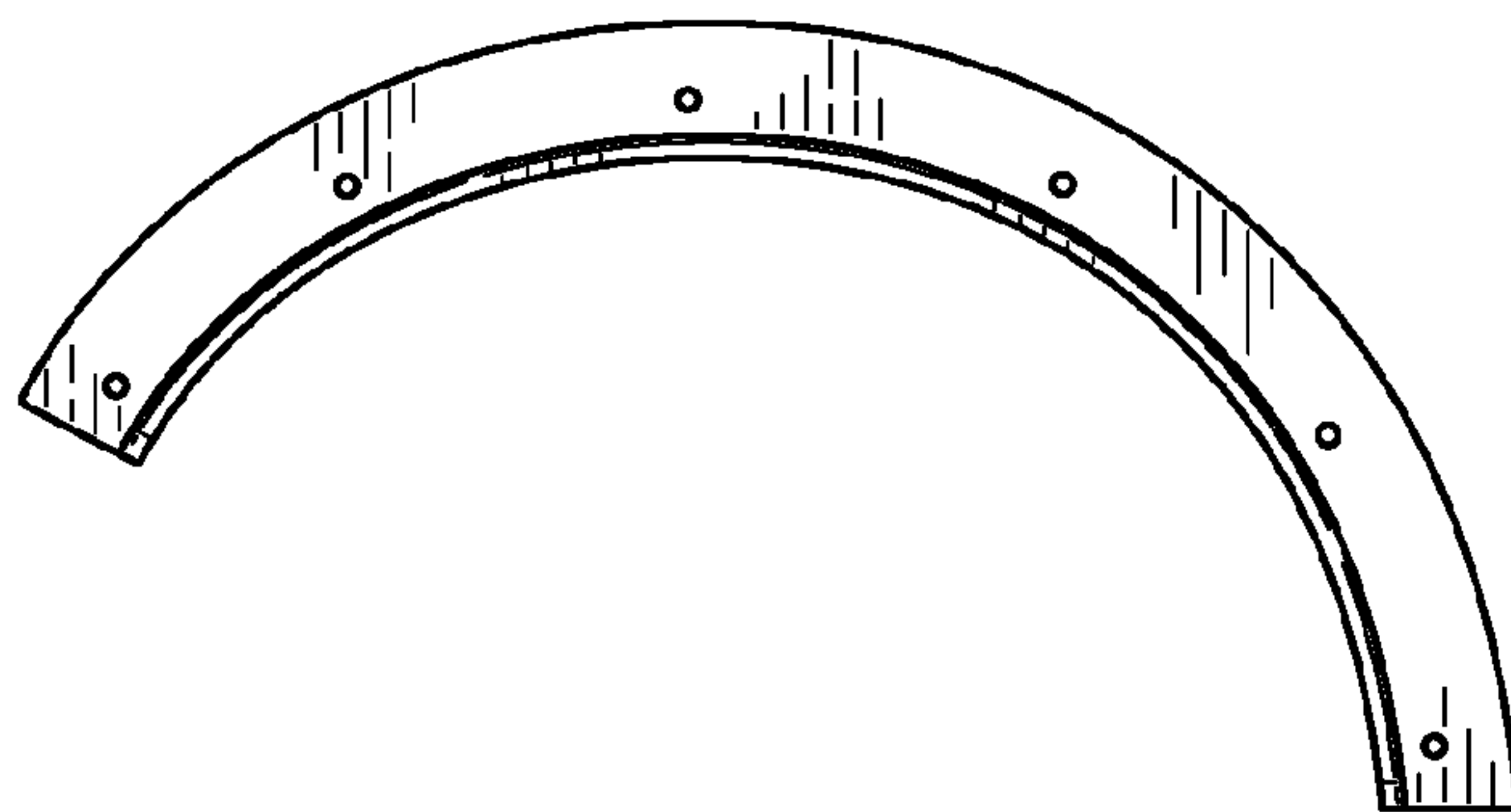

FIG. 4

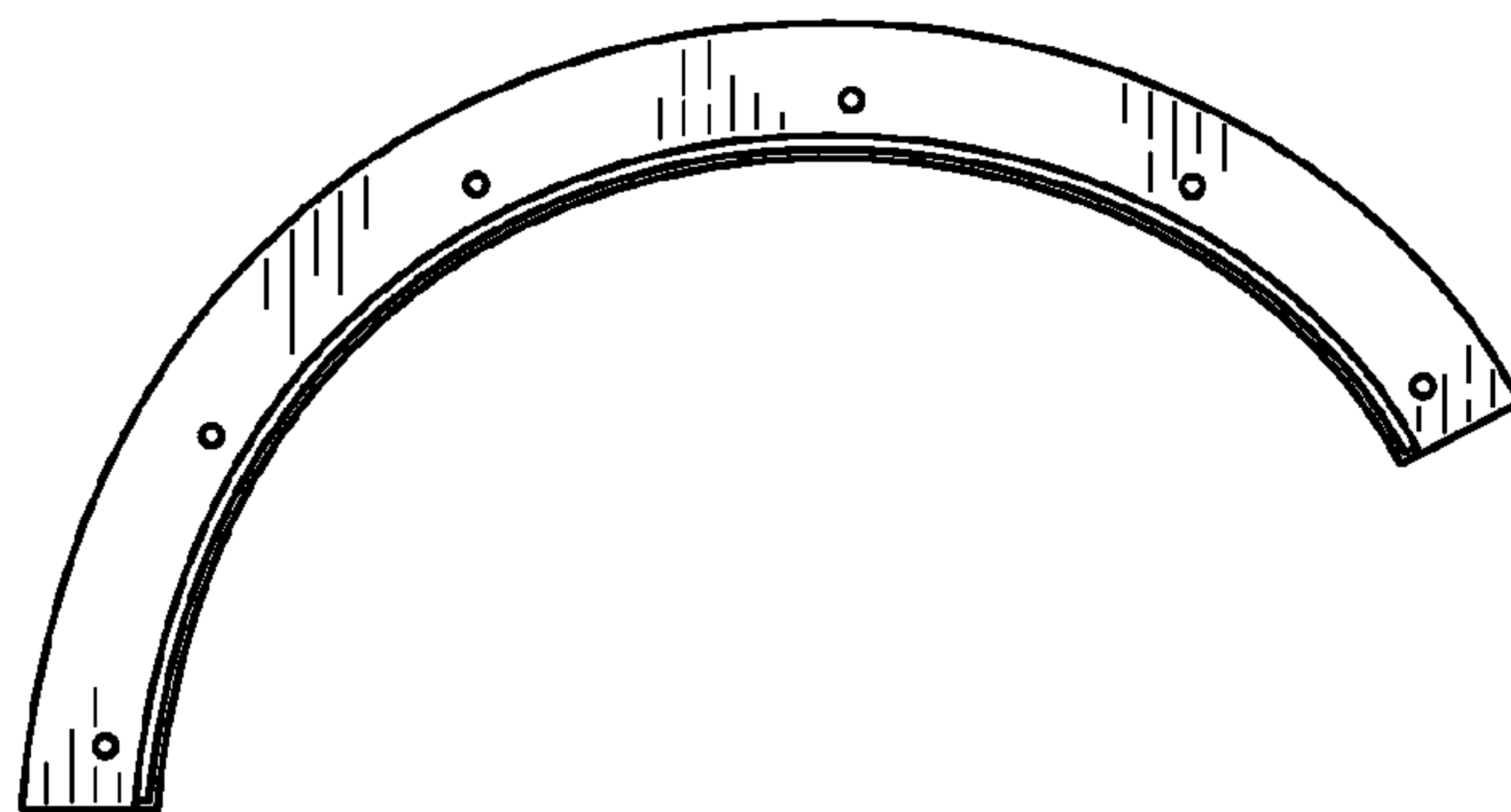

FIG. 5

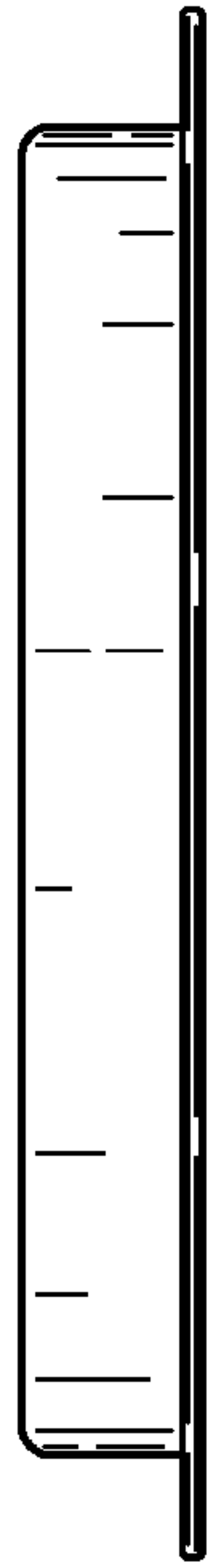

FIG. 6

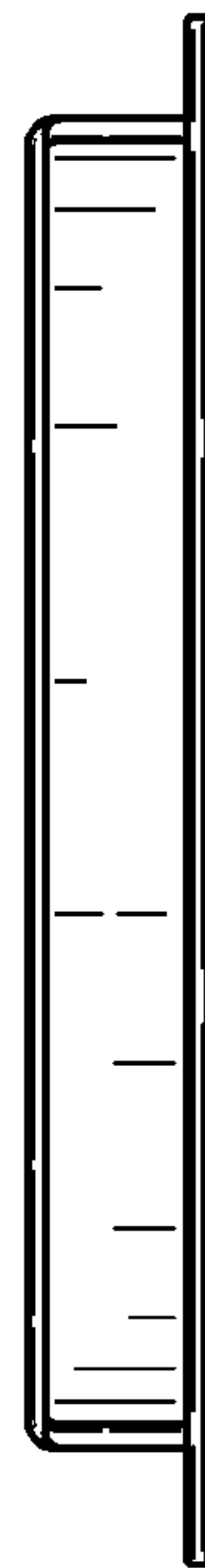

FIG. 7

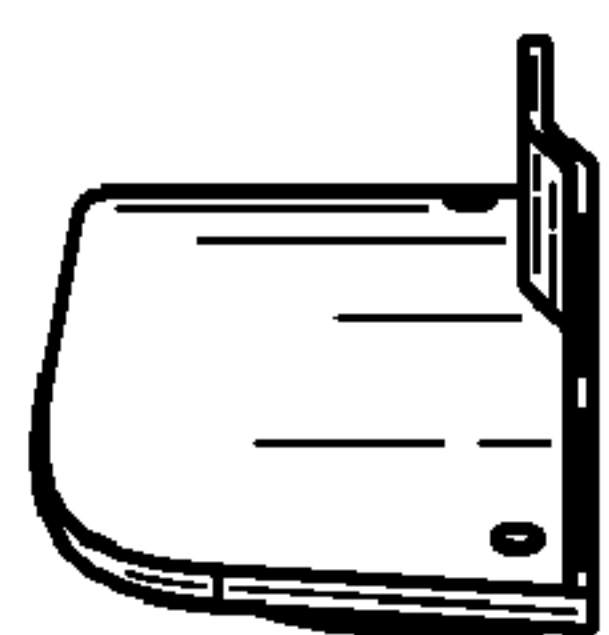

FIG. 8

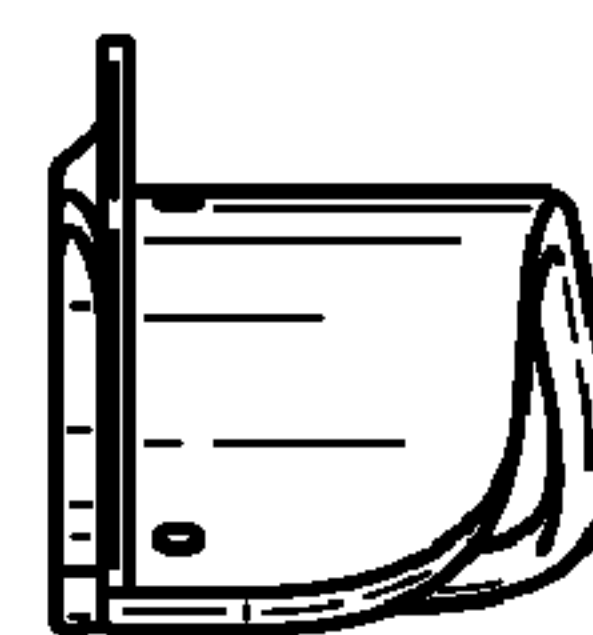

FIG. 9

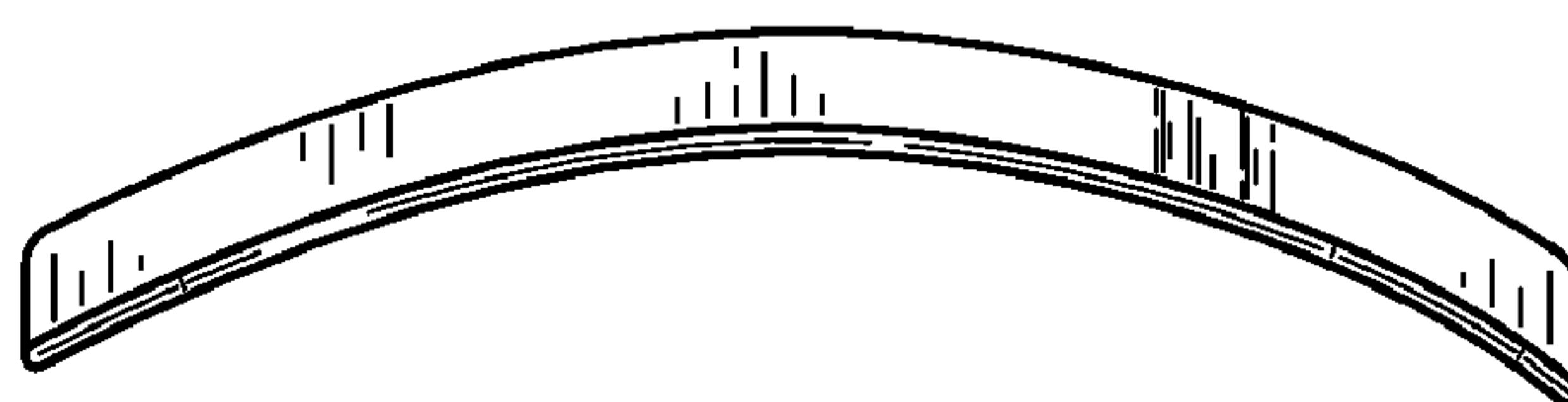

FIG. 10

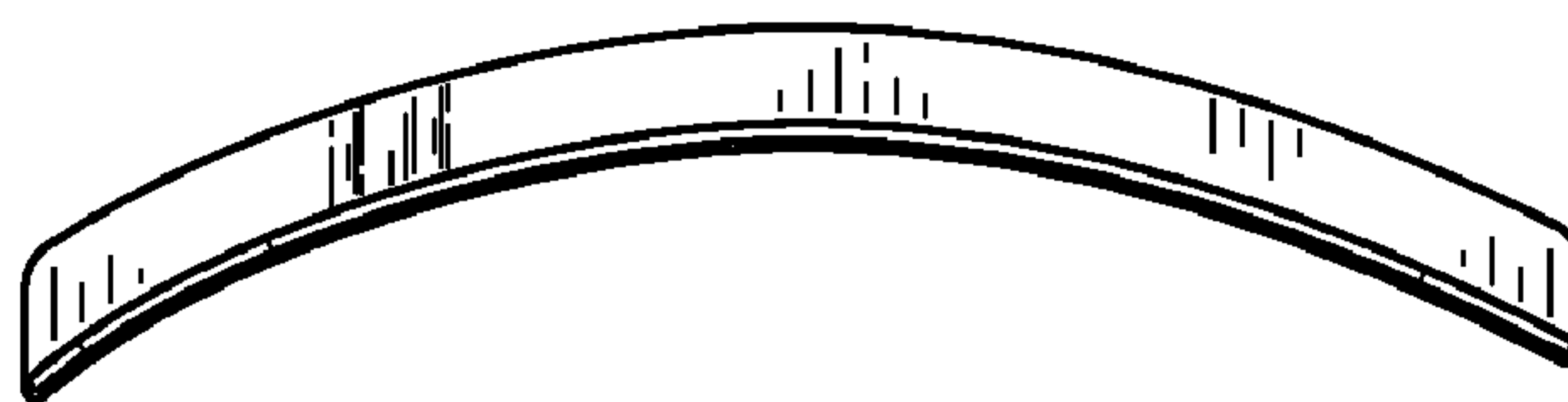

FIG. 11

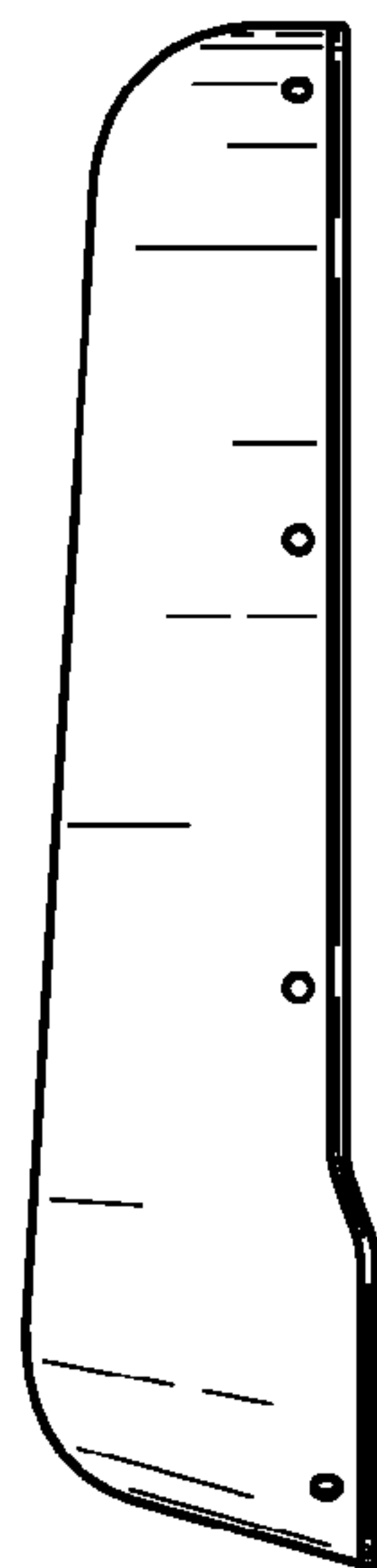

FIG. 12

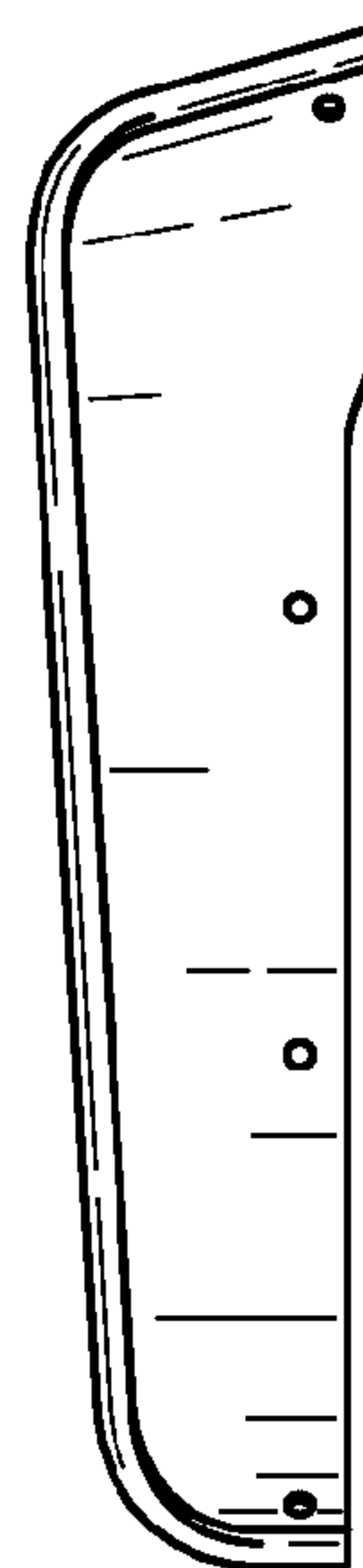

FIG. 13