

US00D610487S

(12) **United States Design Patent**
Zhang

(10) **Patent No.:** **US D610,487 S**

(45) **Date of Patent:** **** Feb. 23, 2010**

(54) **FRONT END OF A VEHICLE**

(75) Inventor: **Xueqing Zhang**, Suzhou (CN)

(73) Assignee: **Suzhou Eagle Electric Vehicle Manufacturing Co., Ltd.**, Suzhou (CN)

(**) Term: **14 Years**

(21) Appl. No.: **29/336,327**

(22) Filed: **Apr. 30, 2009**

(51) **LOC (9) Cl.** **12-14**

(52) **U.S. Cl.** **D12/1; D12/14; D12/16**

(58) **Field of Classification Search** D12/87,
D12/86, 1, 433, 15, 16, 107, 82, 88, 89, 90,
D12/91, 92, 93, 84, 100; D15/30; D21/803;
180/233, 908; 280/DIG. 5, 183, 184, 185,
280/186, 28, 37.7

See application file for complete search history.

(56) **References Cited**

U.S. PATENT DOCUMENTS

D217,810 S *	6/1970	McGinnis	D12/84
D320,960 S *	10/1991	Shea, Sr.	D12/100
D419,107 S *	1/2000	Hofer et al.	D12/86
D419,485 S *	1/2000	Sturges	D12/86
D419,490 S *	1/2000	Hofer et al.	D12/98
D421,411 S *	3/2000	Molzon et al.	D12/82
D425,445 S *	5/2000	Molzon et al.	D12/1
D442,118 S *	5/2001	Molzon et al.	D12/1
6,293,616 B1 *	9/2001	Williams et al.	296/203.01
D465,177 S *	11/2002	Daurelle et al.	D12/84

D483,695 S *	12/2003	Bellington	D12/16
D502,892 S *	3/2005	Miernik	D12/100
D503,126 S *	3/2005	Papke et al.	D12/84
D537,755 S *	3/2007	Toth	D12/84
D552,509 S *	10/2007	Walkup et al.	D12/16
7,287,779 B2 *	10/2007	Miller	280/781
D563,831 S *	3/2008	Suge et al.	D12/84

* cited by examiner

Primary Examiner—T. Chase Nelson

Assistant Examiner—Ania K Dworzecka

(74) *Attorney, Agent, or Firm*—Kenneth H. Ohriner; Perkins Coie LLP

(57) **CLAIM**

The ornamental design for a front end of a vehicle, as shown and described.

DESCRIPTION

FIG. 1 is a front perspective view of a front end of a vehicle showing my new design;

FIG. 2 is a front elevation view thereof;

FIG. 3 is a rear elevation view thereof;

FIG. 4 is a top plan view thereof;

FIG. 5 is a bottom plan view thereof;

FIG. 6 is a left side elevation view thereof; and,

FIG. 7 is a right side elevation view thereof.

In the drawings, the broken lines depict environmental subject matter only and form no part of the claimed design.

1 Claim, 7 Drawing Sheets

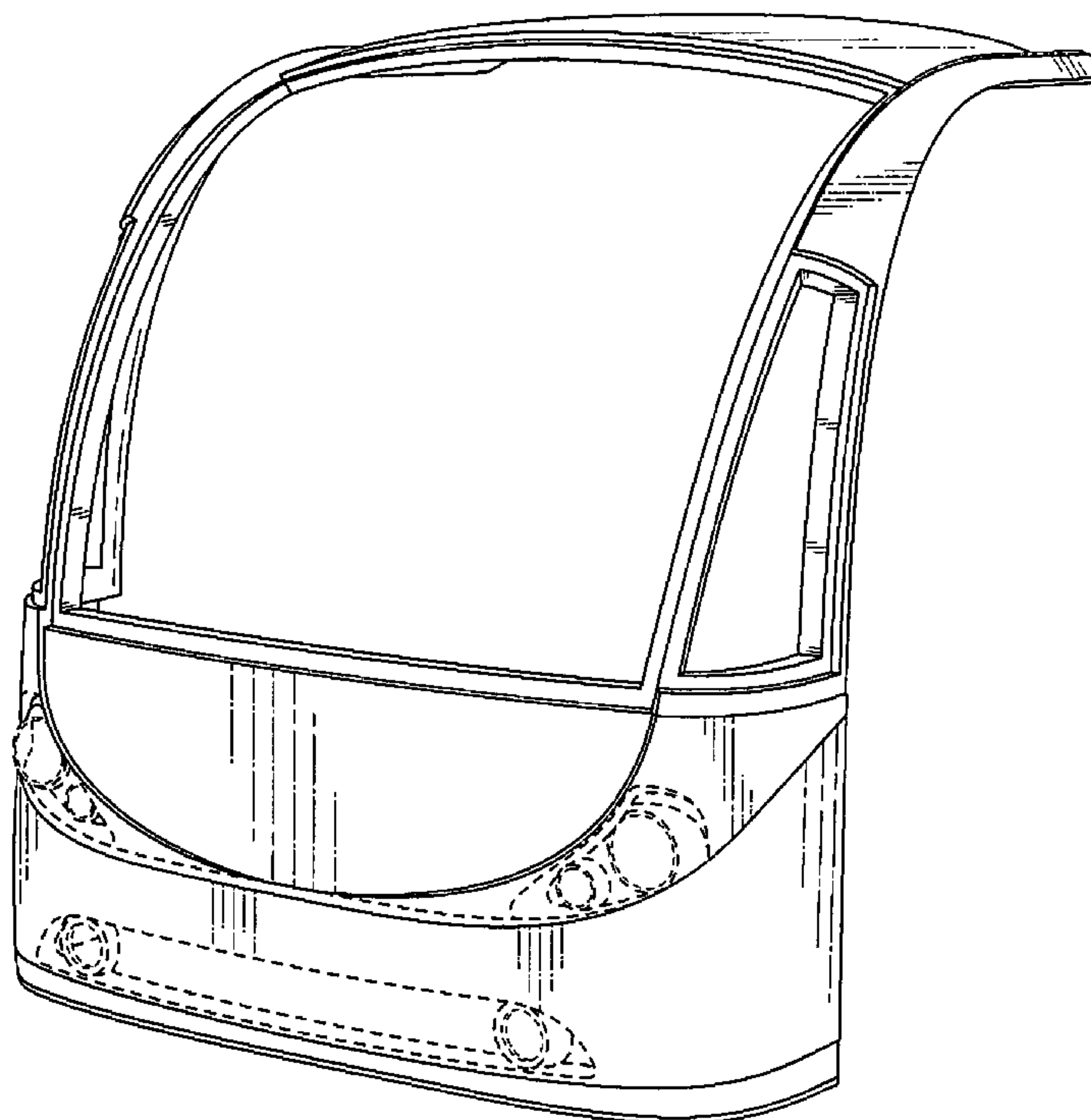

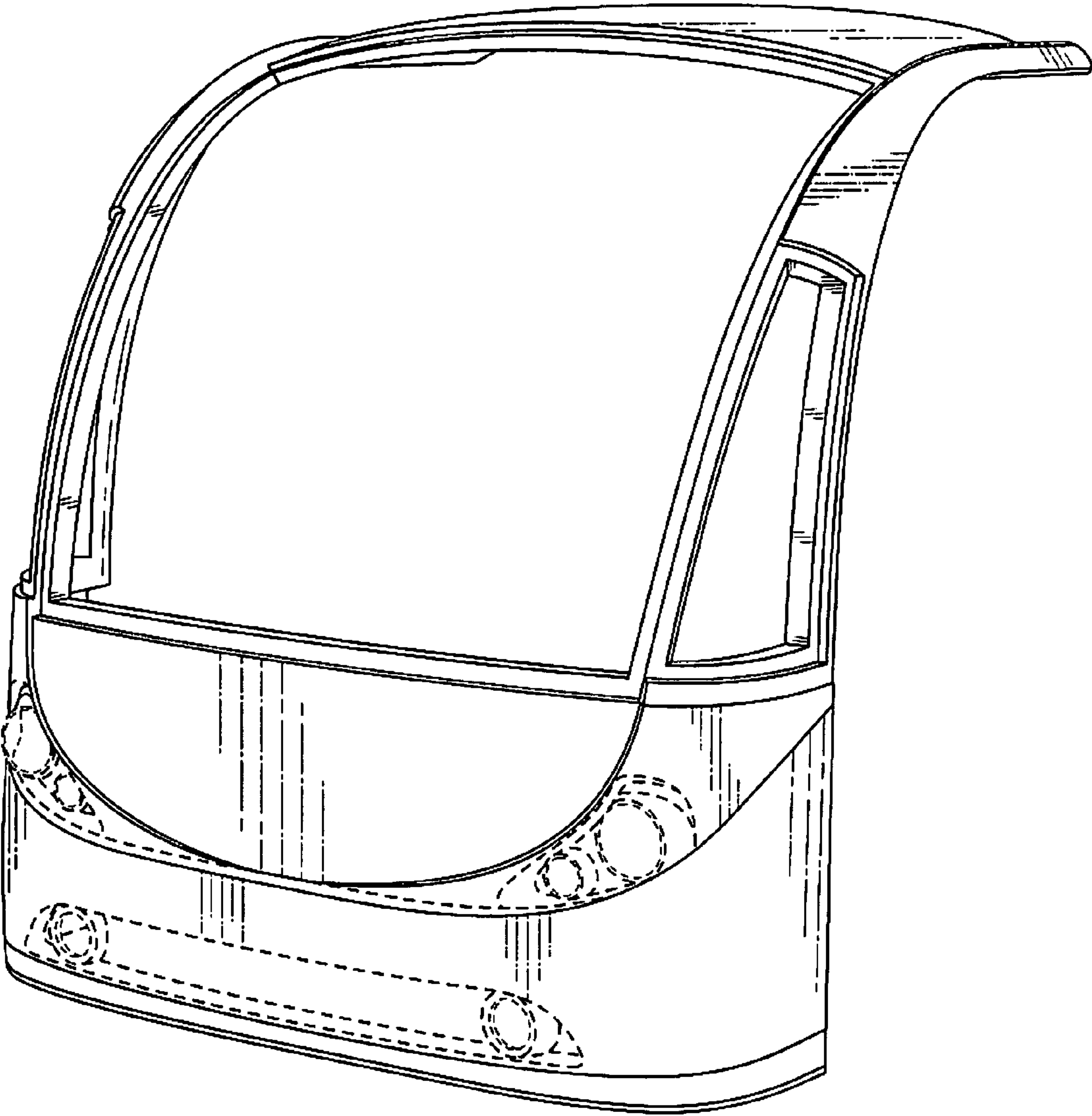

FIG. 1

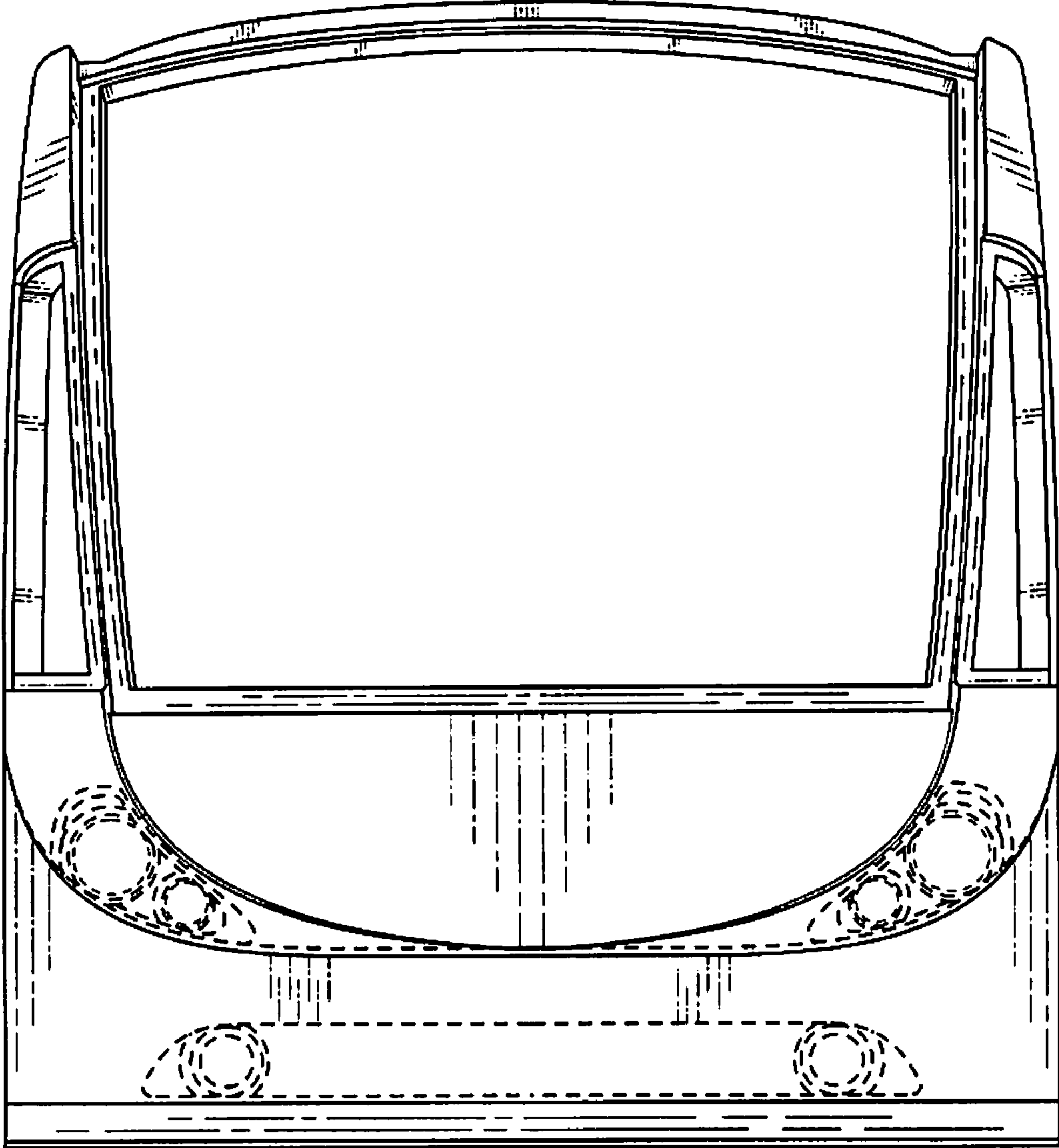

FIG. 2

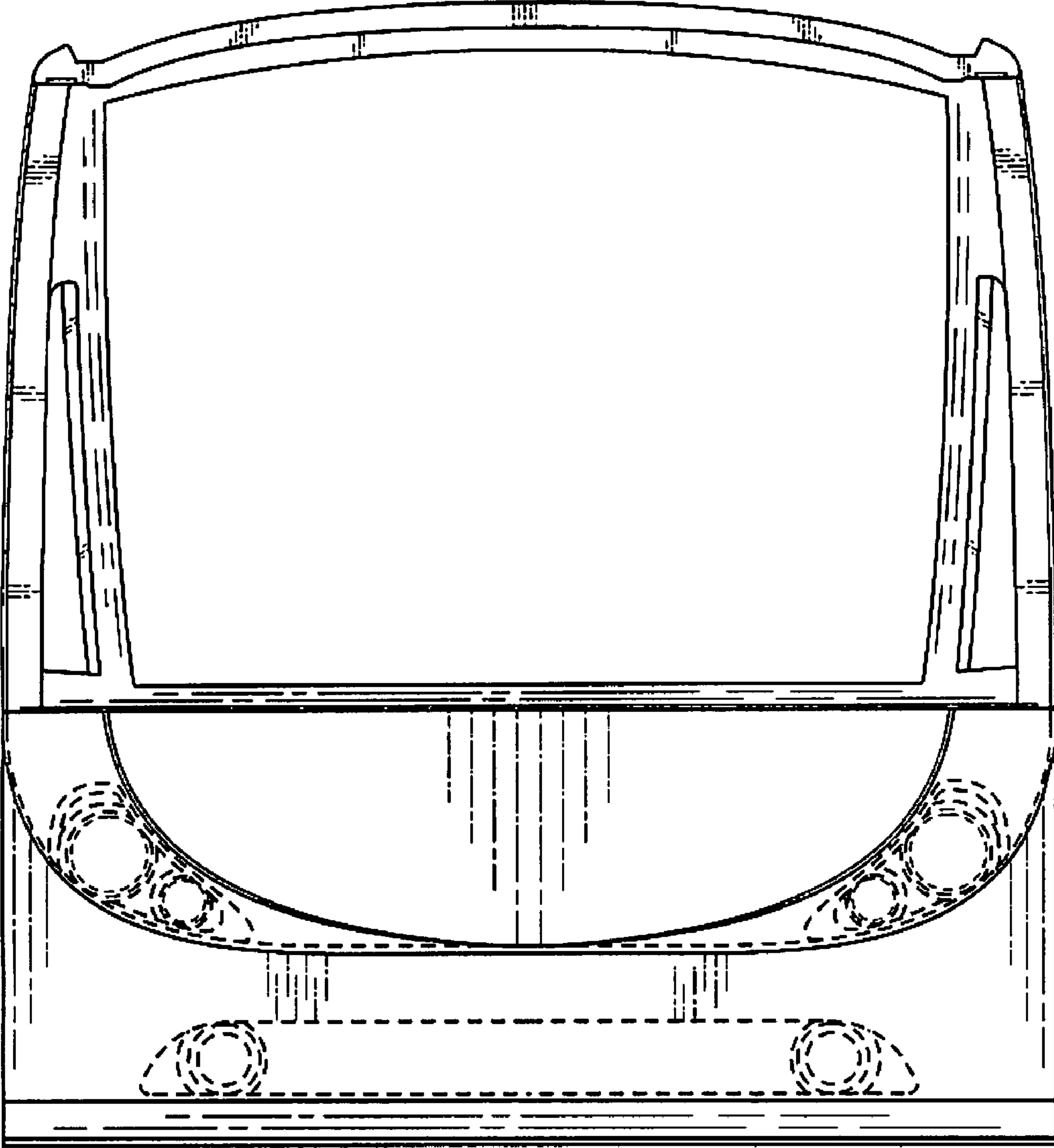

FIG. 3

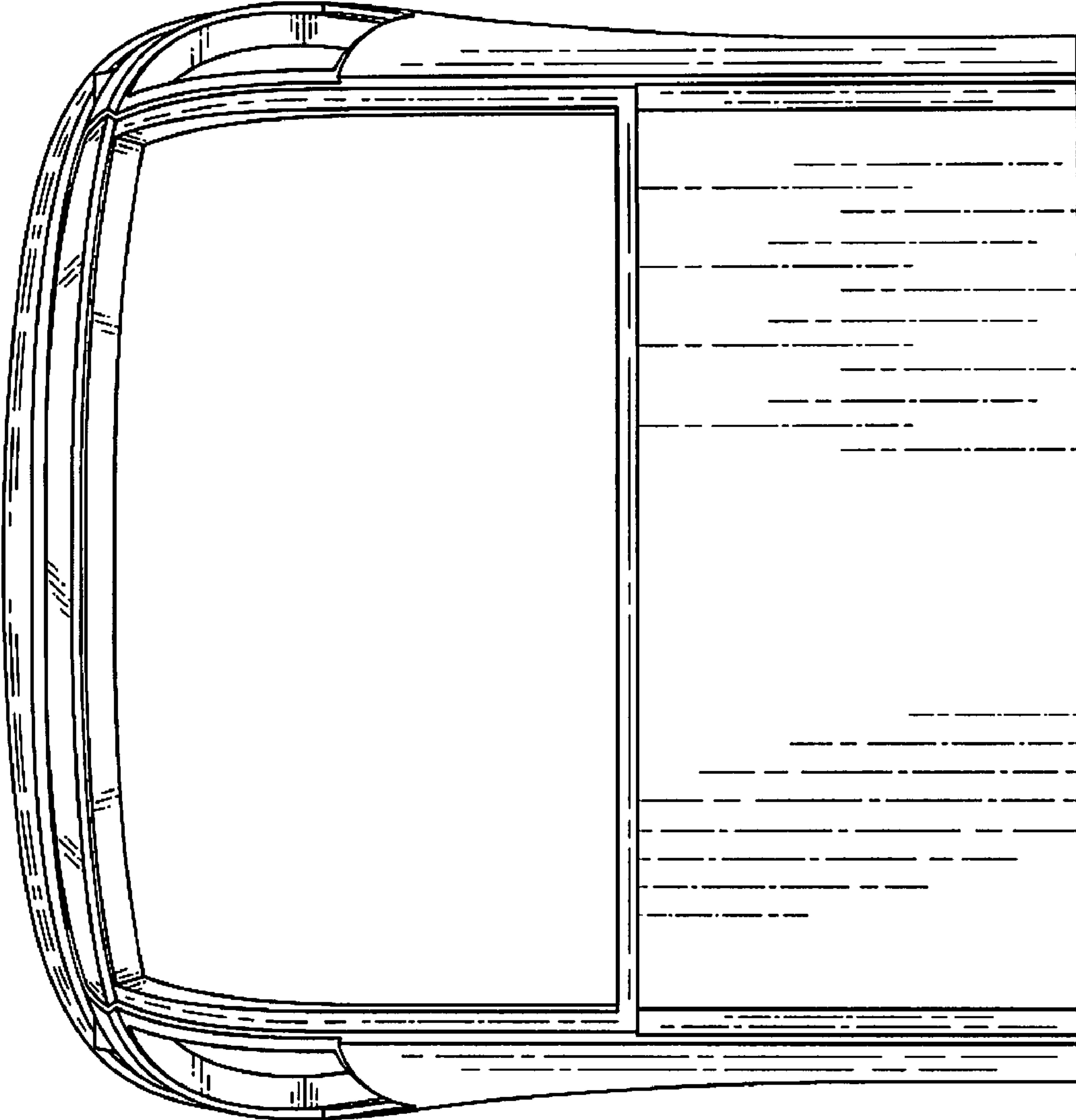

FIG. 4

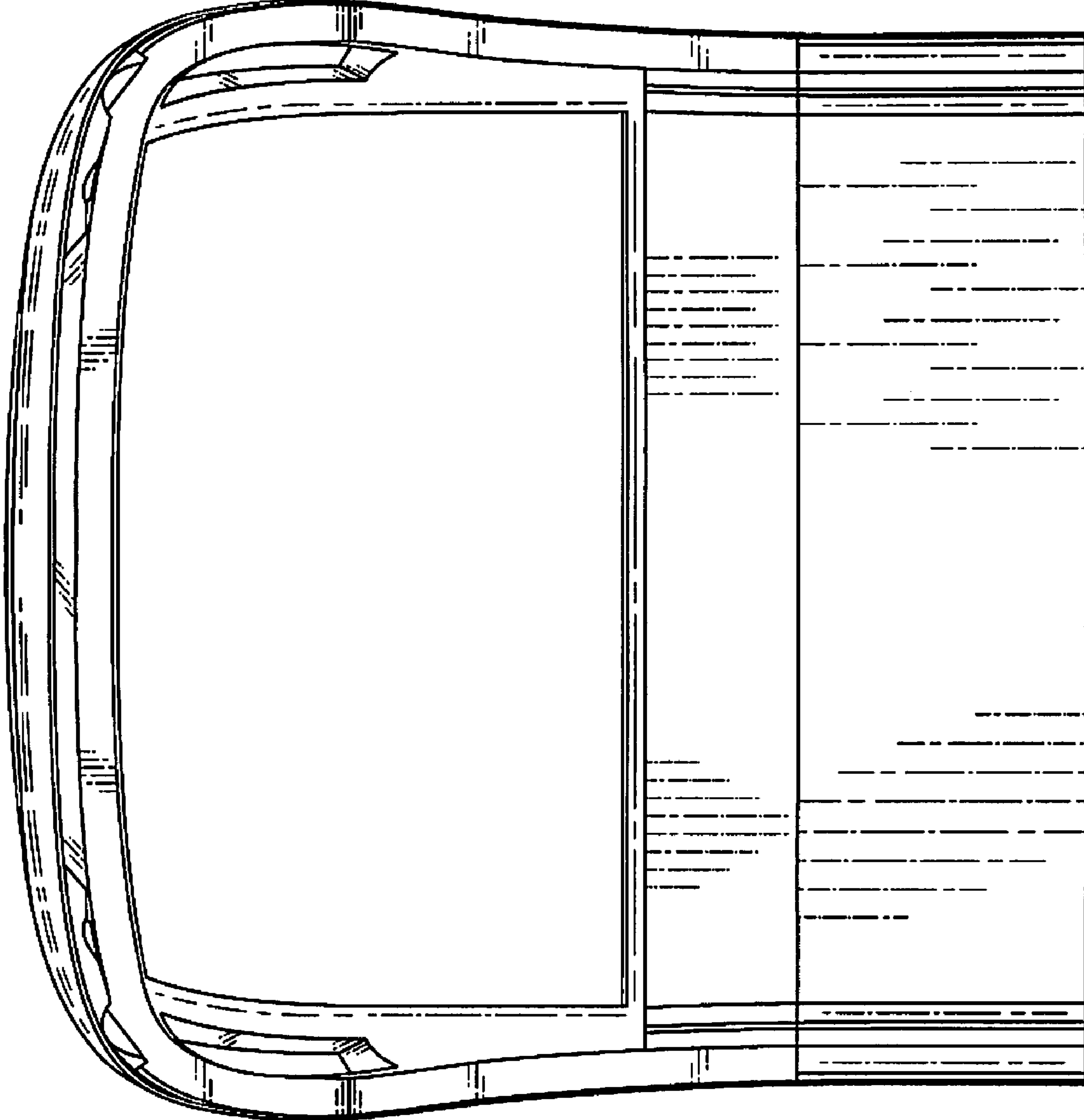

FIG. 5

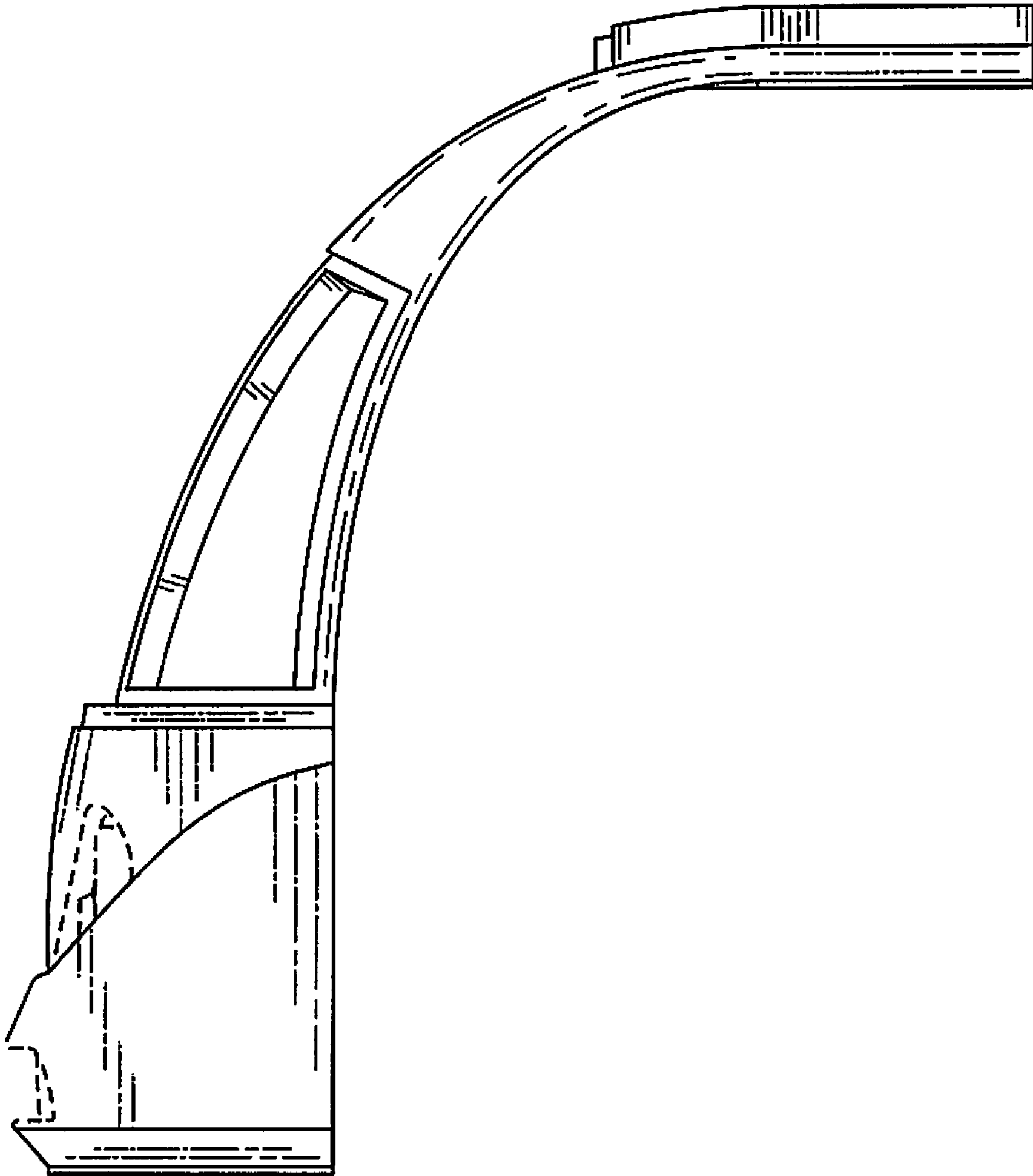

FIG. 6

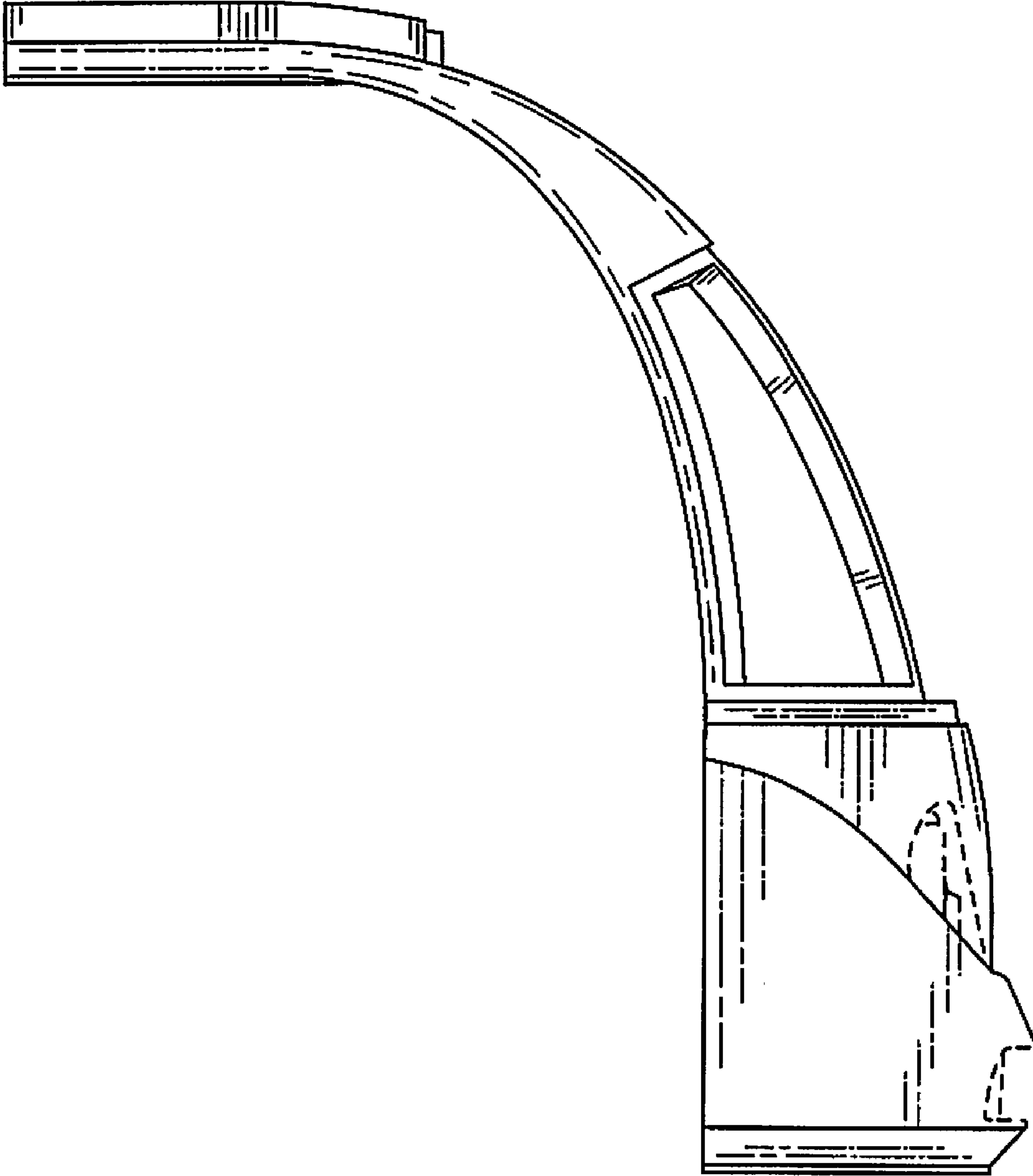

FIG. 7