



US00D610049S

(12) **United States Design Patent**
Curran et al.

(10) **Patent No.:** **US D610,049 S**
(45) **Date of Patent:** **** Feb. 16, 2010**

(54) **BICYCLE CRANK ARM**

(75) Inventors: **Sean Curran**, Clifton, NJ (US);
Dominic Biro, Metuchen, NJ (US)

(73) Assignee: **Animal Bikes, Inc.**, Clifton, NJ (US)

(**) Term: **14 Years**

(21) Appl. No.: **29/313,913**

(22) Filed: **Feb. 18, 2009**

(51) **LOC (9) Cl.** **12-11**

(52) **U.S. Cl.** **D12/123**

(58) **Field of Classification Search** D12/111,
D12/123; 474/152, 164, 160-162, 155-158;
74/594.1-594.4

See application file for complete search history.

(56) **References Cited**

U.S. PATENT DOCUMENTS

3,361,459	A *	1/1968	Marquis et al.	403/165
4,034,575	A *	7/1977	Barth	464/73
4,121,474	A *	10/1978	Arregui Suinaga	474/160
4,811,626	A *	3/1989	Bezin	74/594.1
D319,808	S *	9/1991	Cook	D12/123
5,197,353	A *	3/1993	Trenerry et al.	74/594.1
5,440,950	A *	8/1995	Tranvoiz	74/594.4
6,830,259	B2 *	12/2004	Jakovljevic	280/261
D522,413	S *	6/2006	Okada	D12/123
7,530,290	B2 *	5/2009	Lin	74/594.1

OTHER PUBLICATIONS

Colorado Cyclist Spring 1998, bicycle cranks on p. 30.*

* cited by examiner

Primary Examiner—Philip S Hyder
Assistant Examiner—Linda G. Brooks
(74) *Attorney, Agent, or Firm*—Lawrence G. Fridman

(57) **CLAIM**

The ornamental design for a bicycle crank arm, as shown.

DESCRIPTION

FIG. 1 is a front elevational view of a first embodiment of the bicycle crank arm according to our new design, with the broken lines showing other portions of the bicycle crank arm forming no part of the claimed design.

FIG. 2 is a side elevational view thereof;

FIG. 3 is a rear elevational view thereof;

FIG. 4 is a top plan view thereof;

FIG. 5 is a bottom plan view thereof;

FIG. 6 is an enlarged front perspective view of the first embodiment of the bicycle crank arm, with the broken lines illustrating the boundary of the claimed design and forming no part thereof;

FIG. 7 is a rear perspective view of FIG. 6;

FIG. 8 is front perspective view of a second embodiment of the bicycle crank arm; with the broken lines illustrating the boundary of the claimed design and forming no part thereof; and,

FIG. 9 is a rear perspective view of FIG. 8.

The front, side and rear elevational views and the top and bottom plan views of the second embodiment are the same as those in FIGS. 1-5.

1 Claim, 4 Drawing Sheets

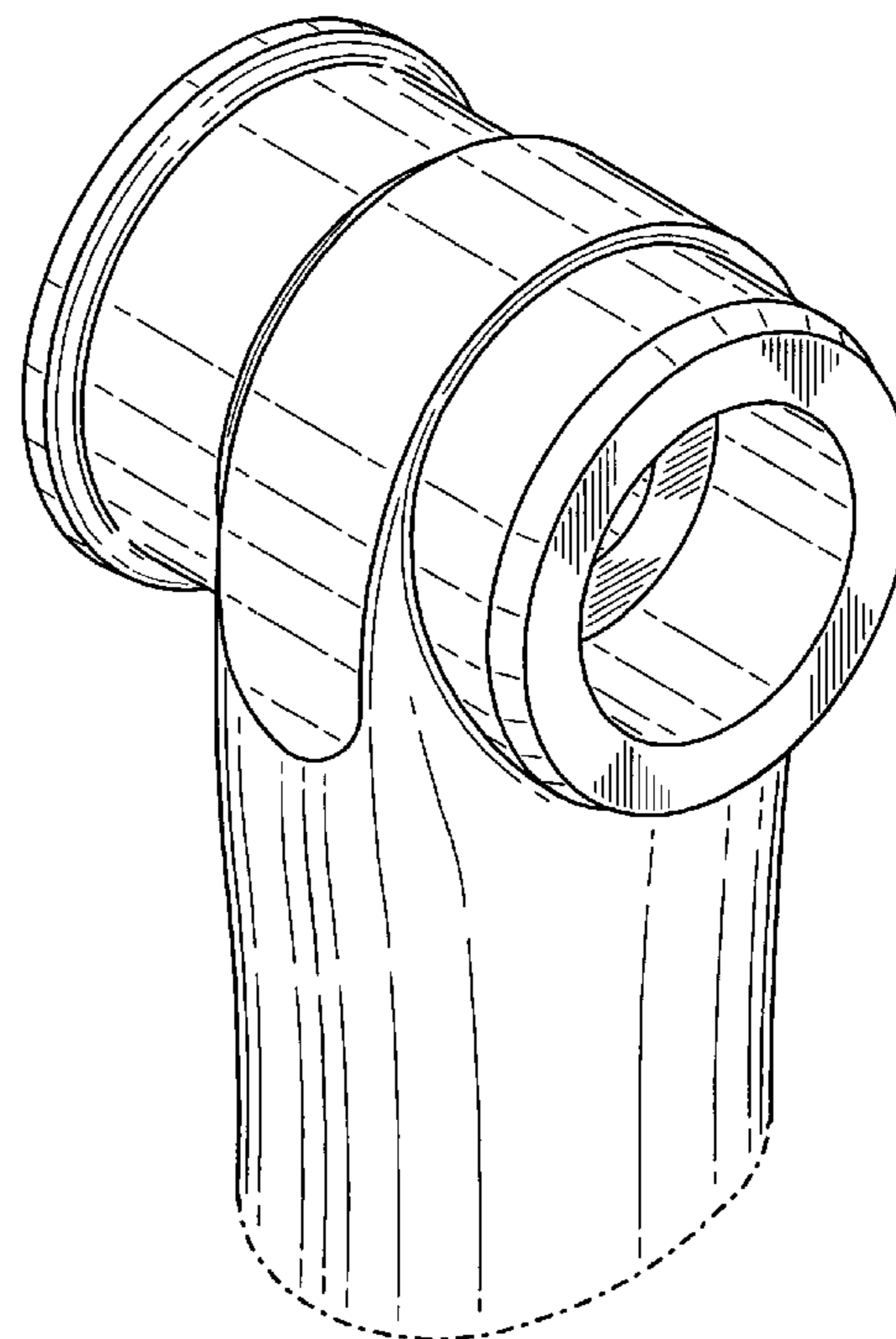
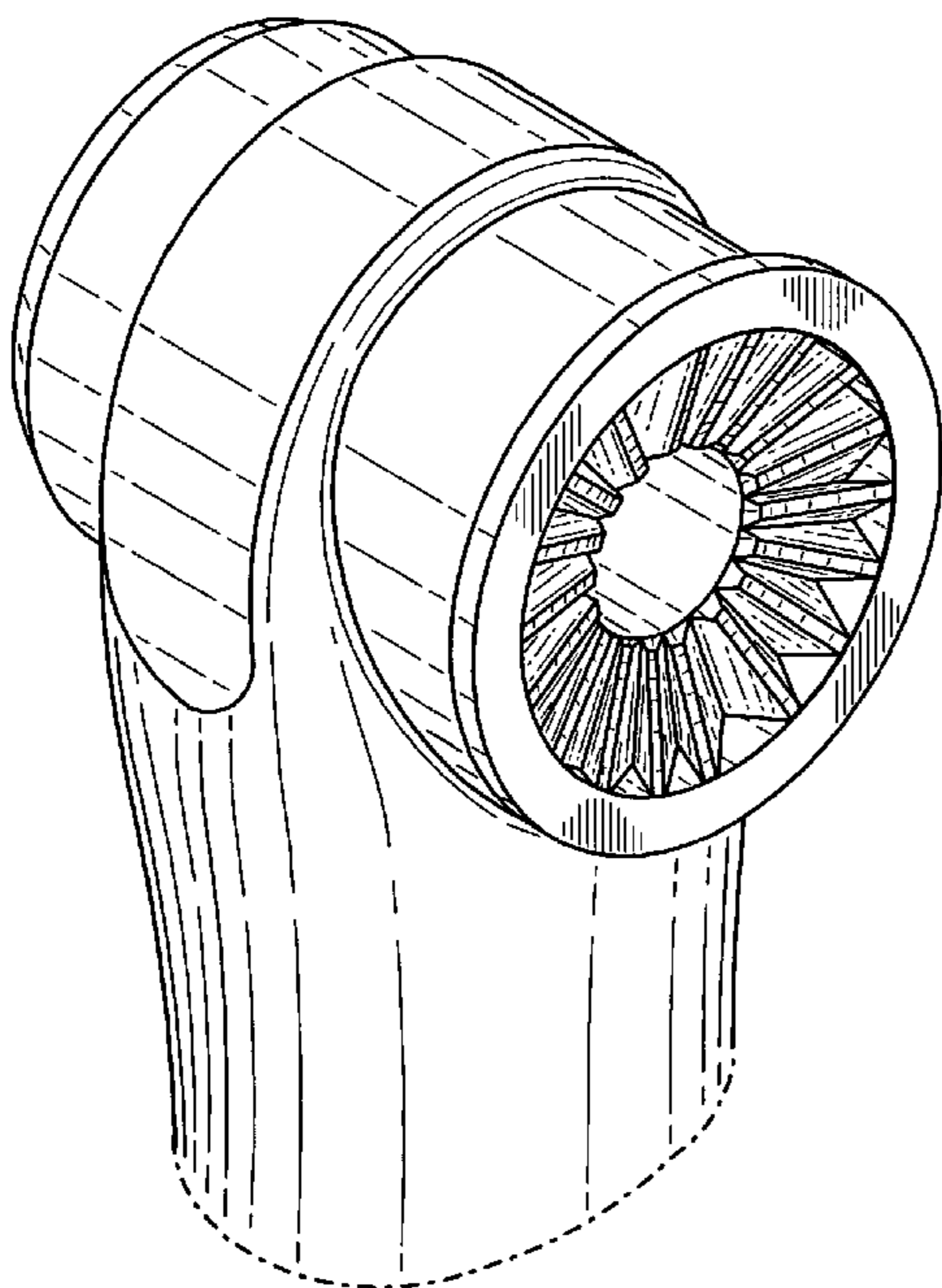

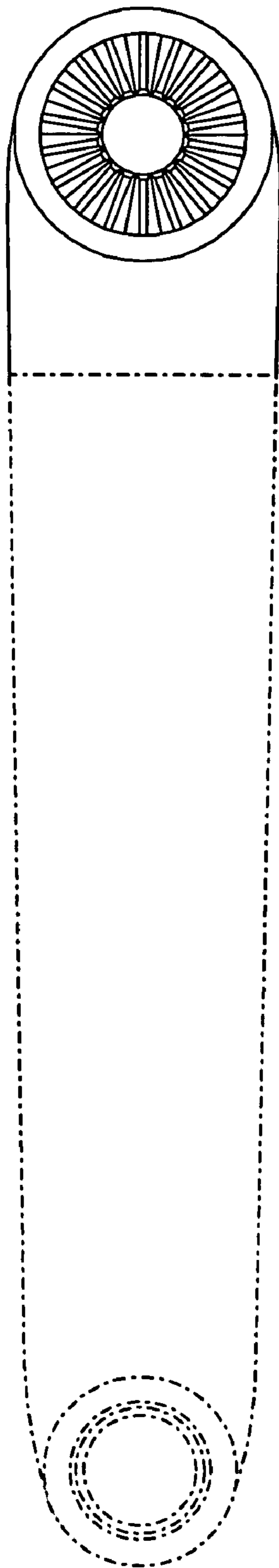

FIG. 1

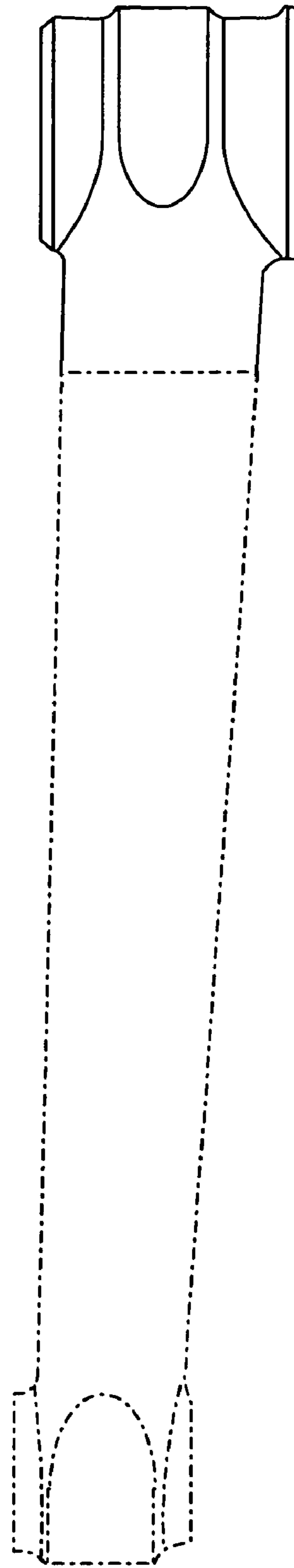

FIG. 2

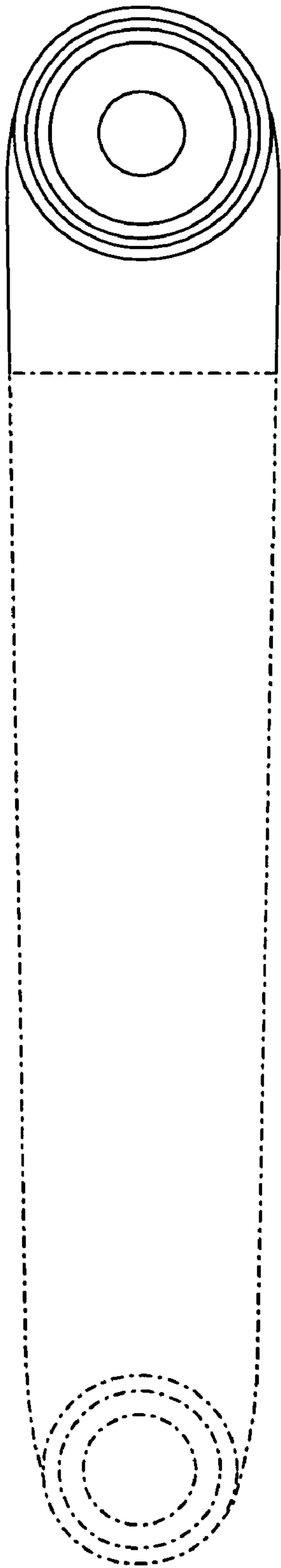

FIG. 3

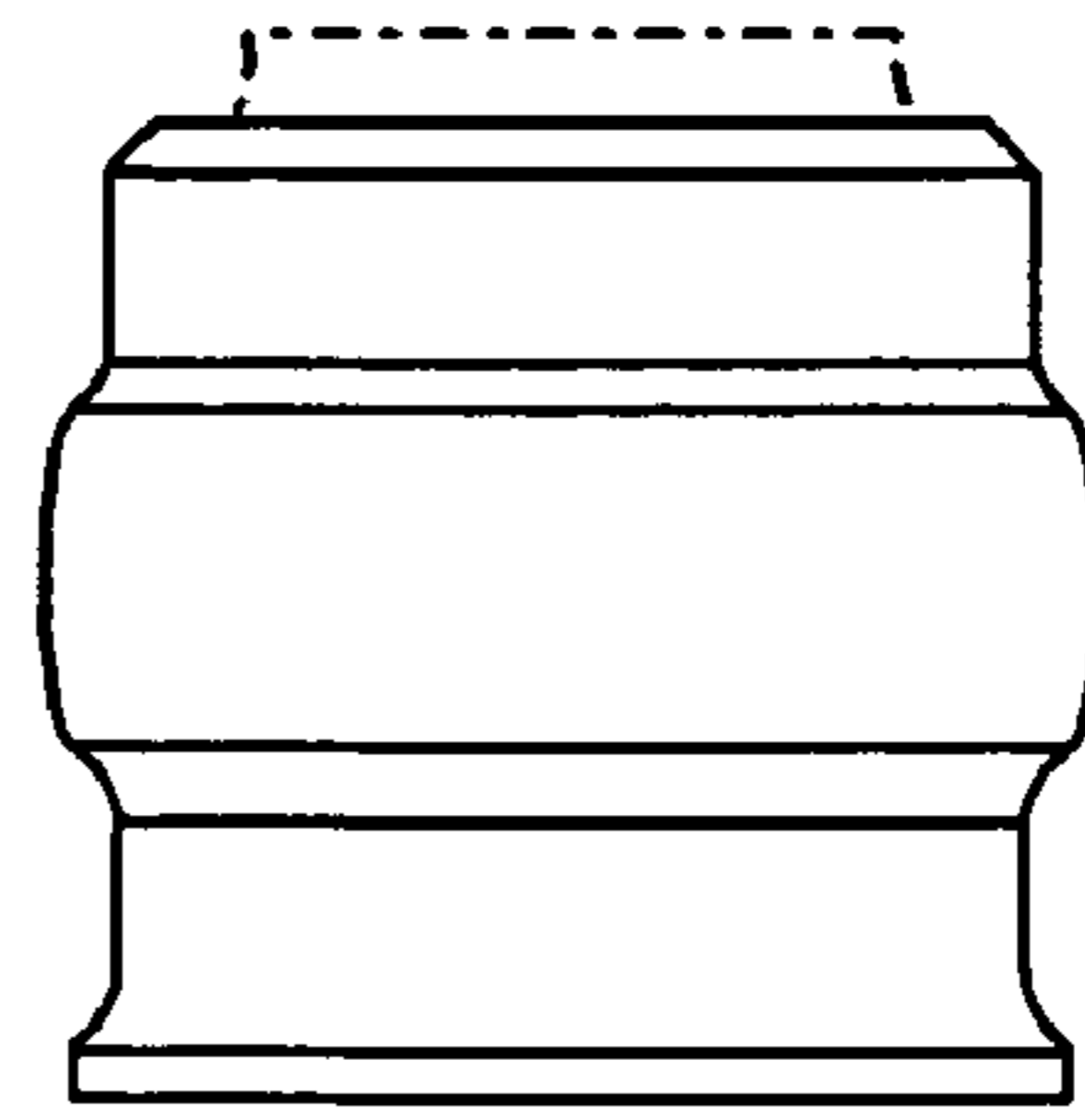

FIG. 4

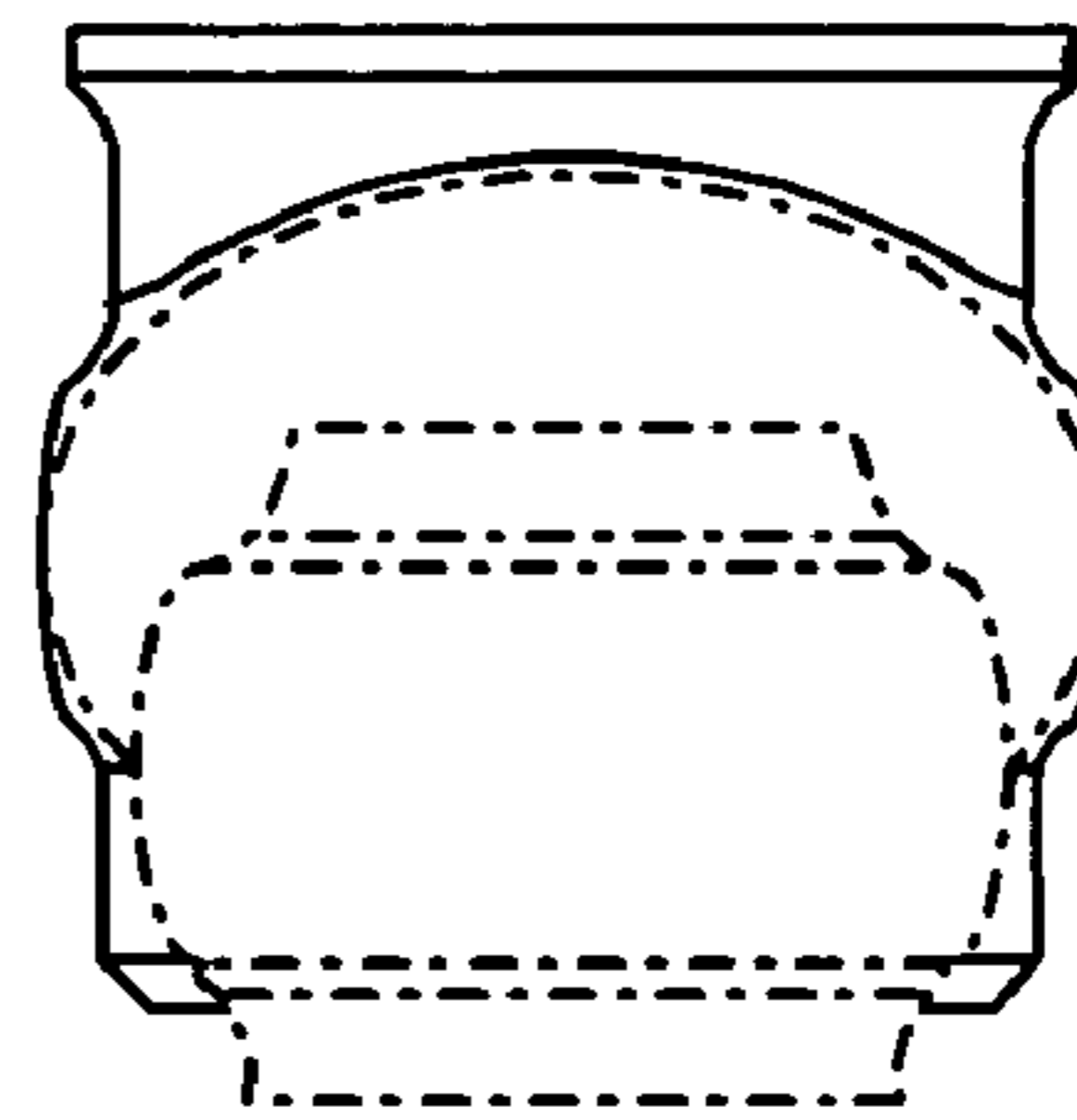

FIG. 5

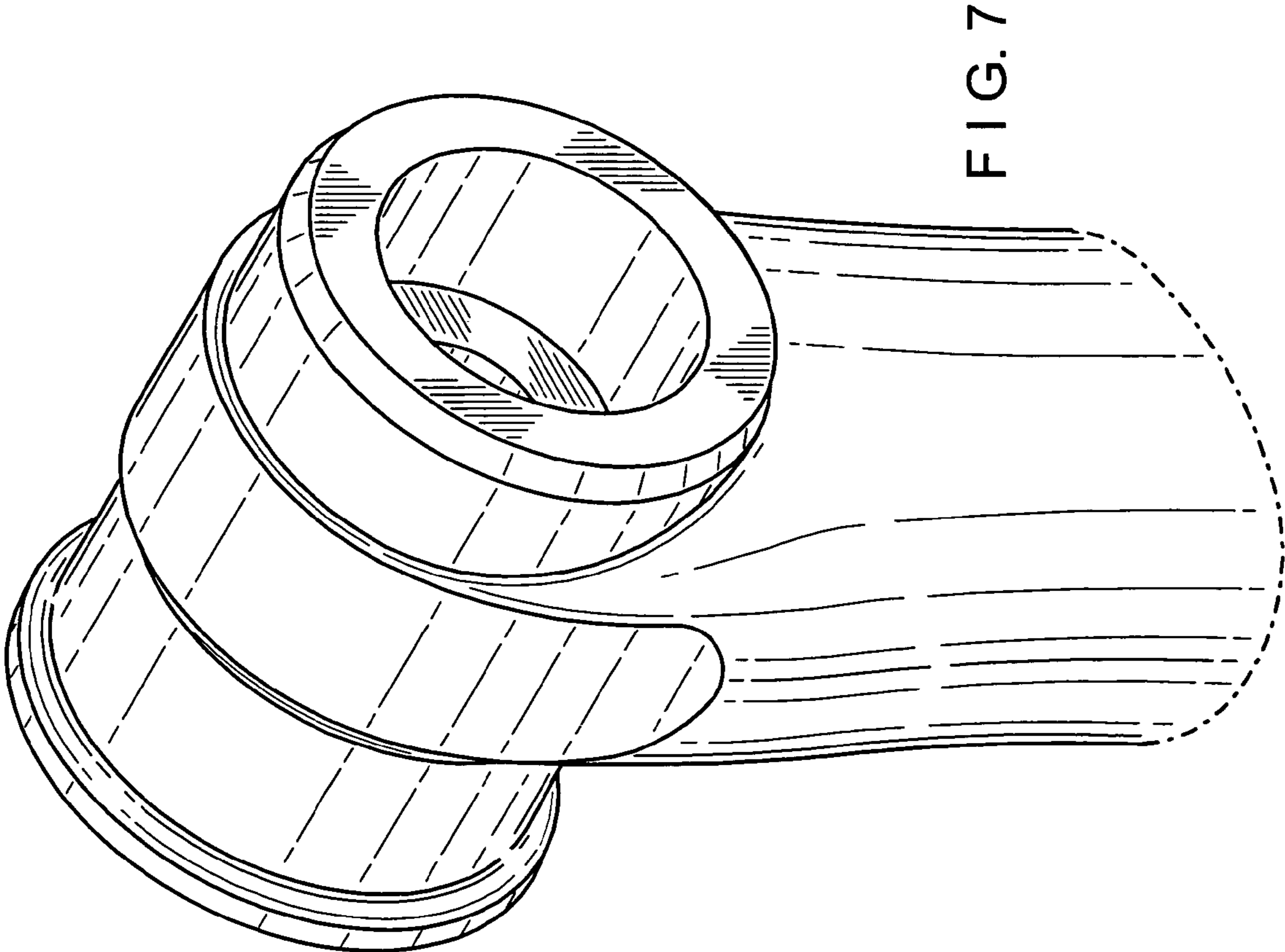

FIG. 7

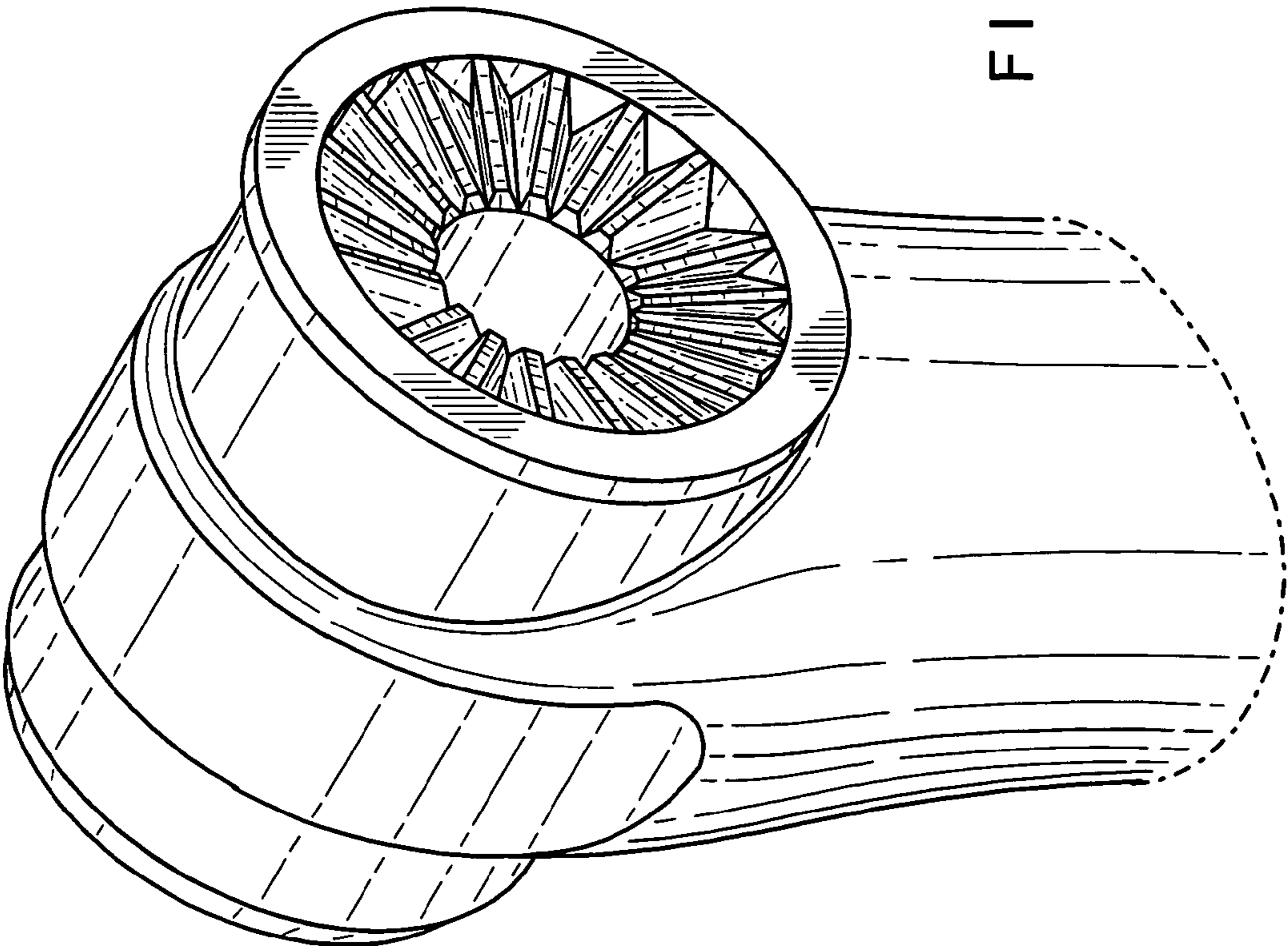

FIG. 6

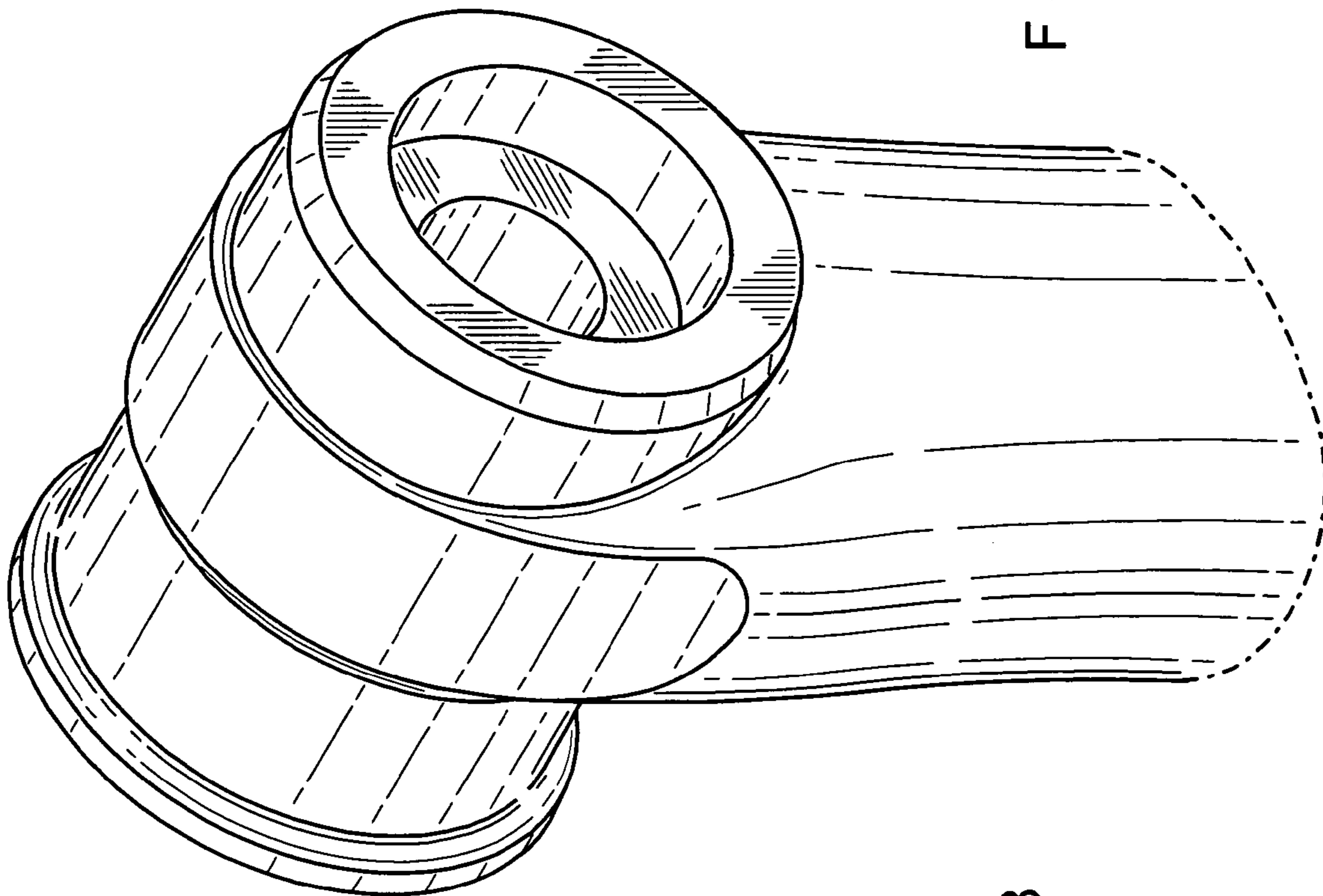

FIG. 9

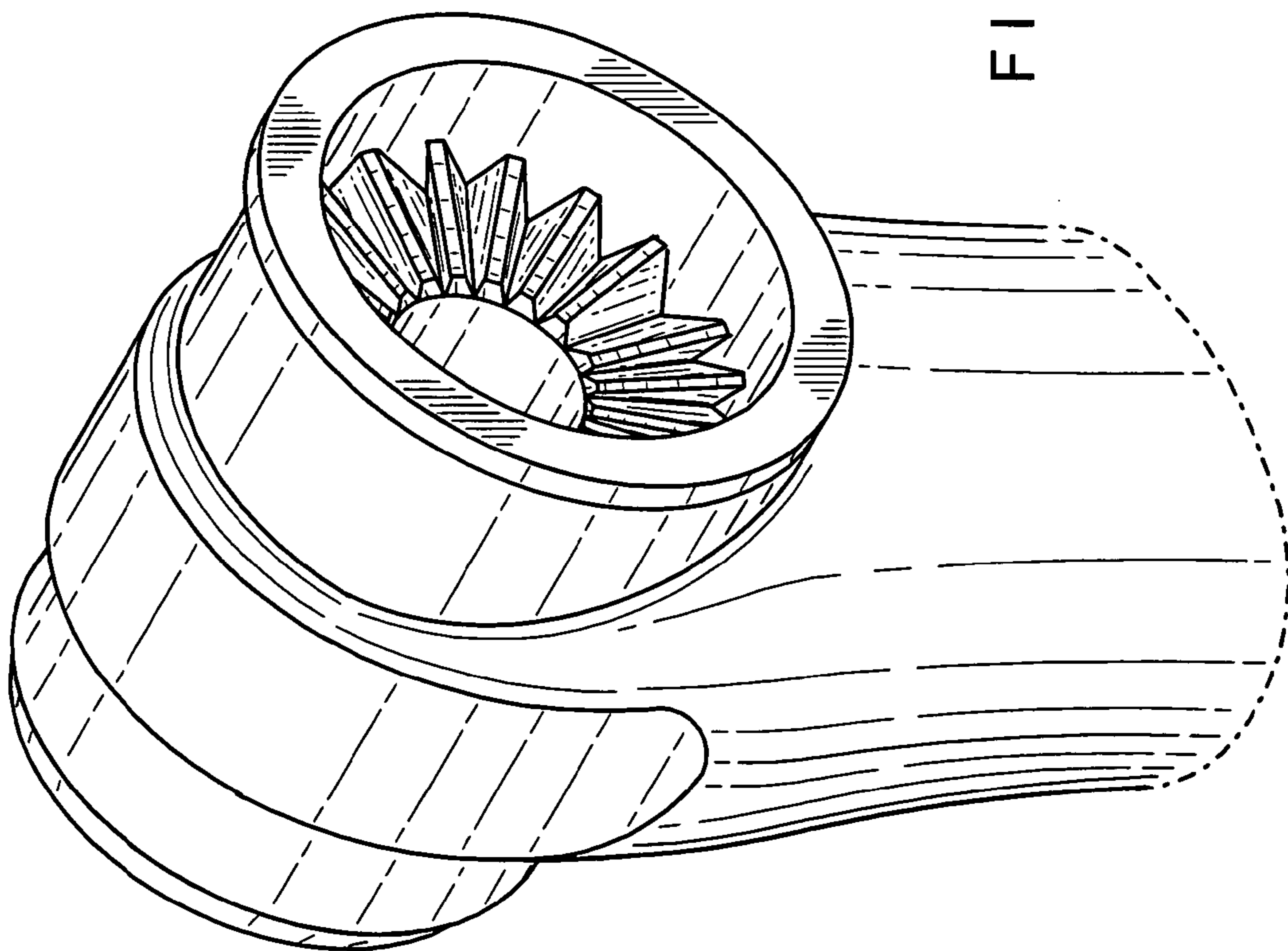

FIG. 8