

US00D609627S

(12) **United States Design Patent**  
**Frappart et al.**

(10) **Patent No.:** **US D609,627 S**

(45) **Date of Patent:** **\*\* Feb. 9, 2010**

(54) **PNEUMATIC TIRE**

D599,277 S \* 9/2009 Froger et al. .... D12/521

(75) Inventors: **Arnaud Frappart**, Chamalieres (FR);  
**Patrice Fraysse**, Blanzat (FR);  
**Emmanuel Igier**, Aigueperse (FR)

(73) Assignee: **Michelin Recherche et Technique S.A.**,  
Granges-Paccot (CH)

(\*\*) Term: **14 Years**

(21) Appl. No.: **29/300,854**

(22) Filed: **May 21, 2008**

(30) **Foreign Application Priority Data**

Nov. 22, 2007 (FR) ..... 07/5341

(51) **LOC (9) Cl.** ..... **12-16**

(52) **U.S. Cl.** ..... **D12/523**

(58) **Field of Classification Search** ..... D12/505-532;  
152/209.1, 209.8, 209.9, 209.12, 209.18,  
152/209.25

See application file for complete search history.

(56) **References Cited**

**U.S. PATENT DOCUMENTS**

D423,422 S	4/2000	Selover et al.	
D432,956 S	10/2000	Ricquet	
D432,957 S	10/2000	Ricquet	
D510,064 S	9/2005	Hildebrand	
D525,186 S	7/2006	Martin	
D558,128 S	* 12/2007	Delu et al.	D12/521
D561,682 S	* 2/2008	Ohki	D12/519
D561,683 S	* 2/2008	Kiwaki	D12/519
D584,213 S	* 1/2009	Shinkai	D12/519
D586,726 S	* 2/2009	Baumard et al.	D12/521
D599,276 S	* 9/2009	Fontaine et al.	D12/519

**OTHER PUBLICATIONS**

“Continental Sport contact 3”, Tire Global Information, *Tire Book 2008, International Edition*, vol. 12, Friedrich Lux, Wr. Neustadt, Austria (2008).

“Continental Sport contact 2”, Tire Global Information, *Tire Book 2008, International Edition*, vol. 12, Friedrich Lux, Wr. Neustadt, Austria (2008).

“Imperio SI-GT (H rated)”, Tire Global Information, *Tire Book 2008, International Edition*, vol. 12, Friedrich Lux, Wr. Neustadt, Austria (2008).

“Michelin Pilot Sport (Y rated)”, Tire Global Information, *Tire Book 2008, International Edition*, vol. 12, Friedrich Lux, Wr. Neustadt, Austria (2008).

“Pirelli P Zero C (Z rated)”, Tire Global Information, *Tire Book 2008, International Edition*, vol. 12, Friedrich Lux, Wr. Neustadt, Austria (2008).

\* cited by examiner

*Primary Examiner*—Caron Veynar

*Assistant Examiner*—George D Kirschbaum

(74) *Attorney, Agent, or Firm*—Buchanan Ingersoll & Rooney PC

(57) **CLAIM**

The ornamental design for a pneumatic tire, as shown and described.

**DESCRIPTION**

FIG. 1 is a top perspective view of a pneumatic tire according to our new design, it being understood that the tire pattern repeats circumferentially about the outer circumference.

FIG. 2 is a front elevational view thereof.

FIG. 3 is a rear elevational view thereof.

FIG. 4 is a right side elevational view thereof; and,

FIG. 5 is a left side elevational view thereof.

**1 Claim, 5 Drawing Sheets**

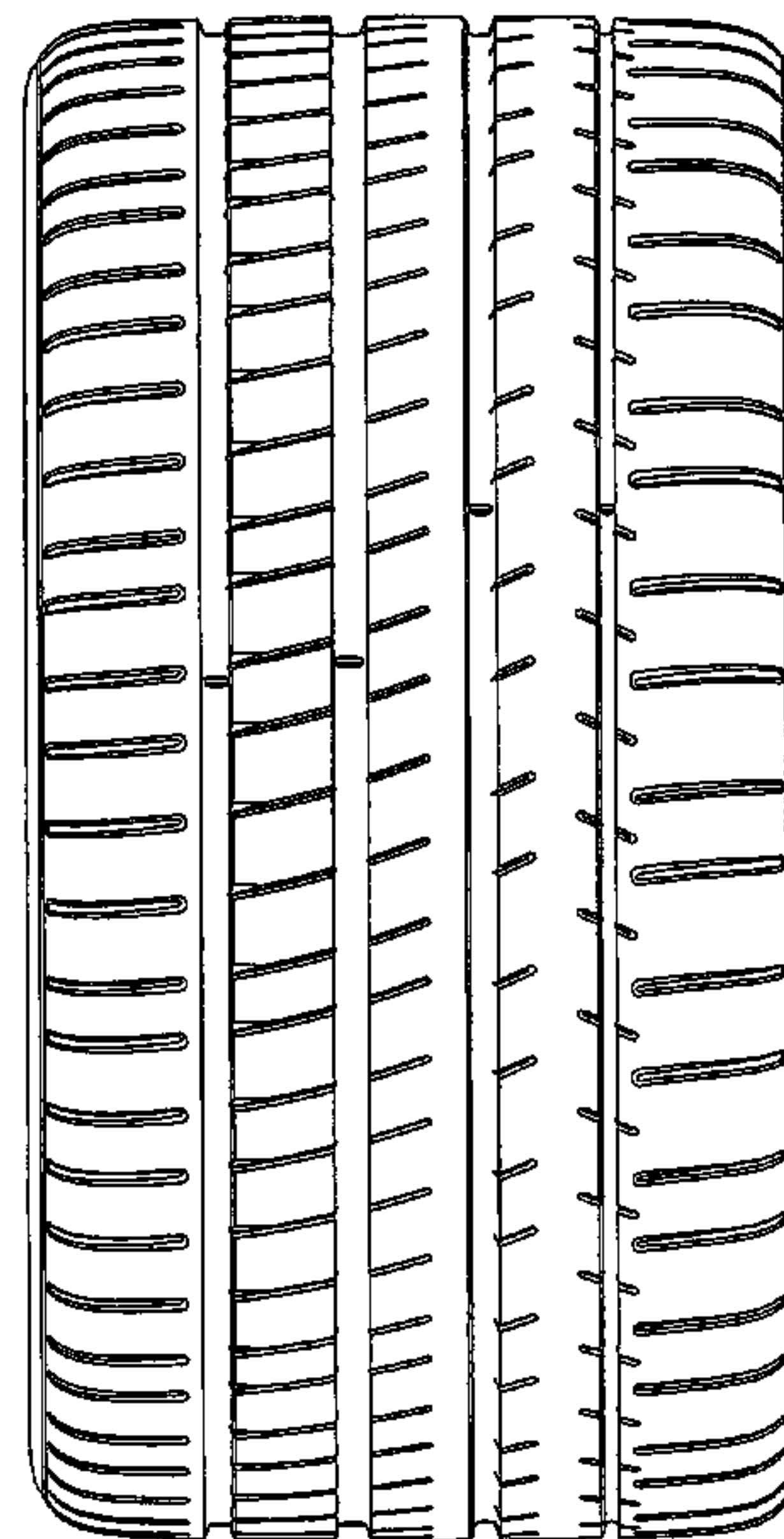
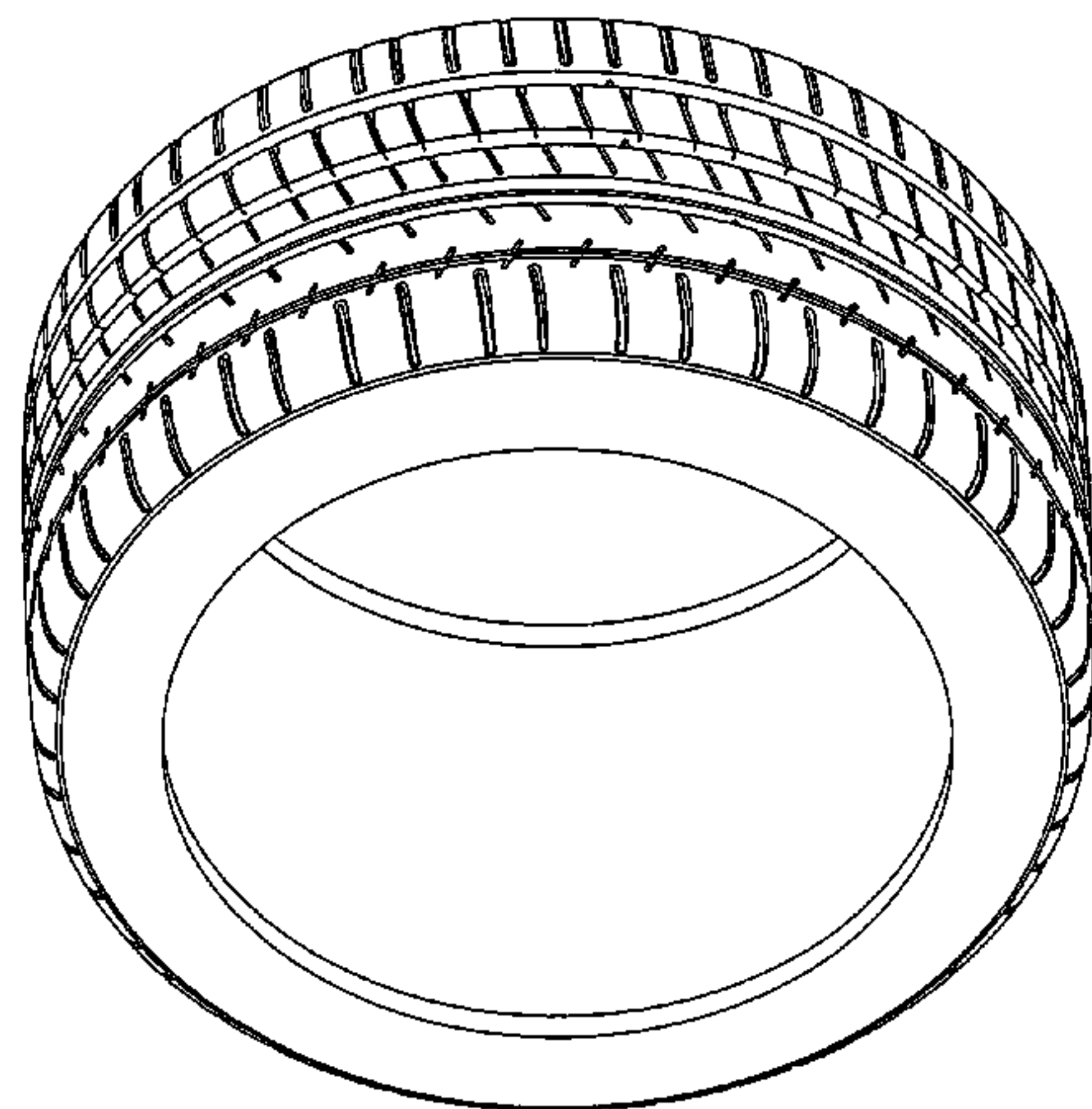

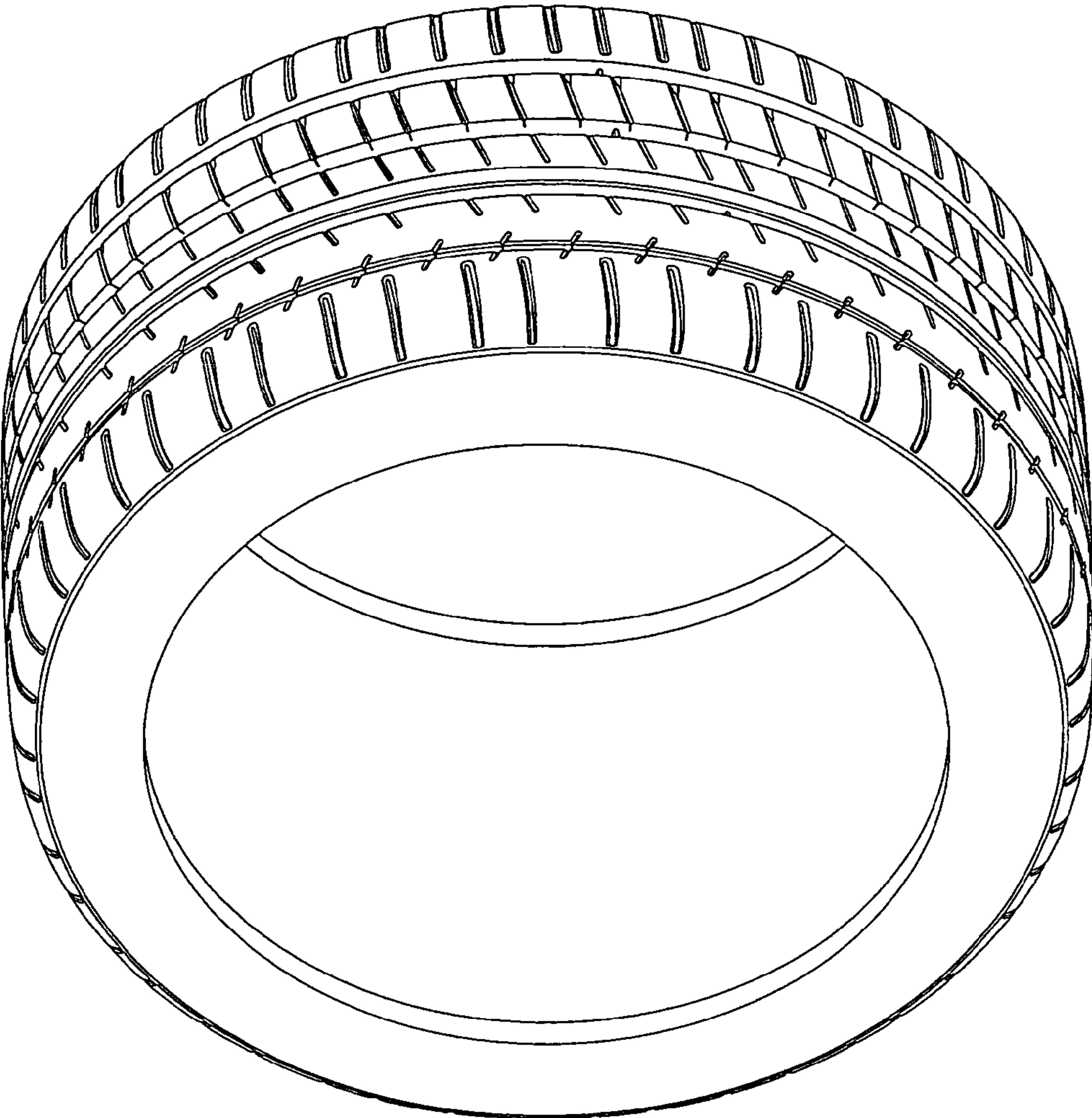

FIG. 1

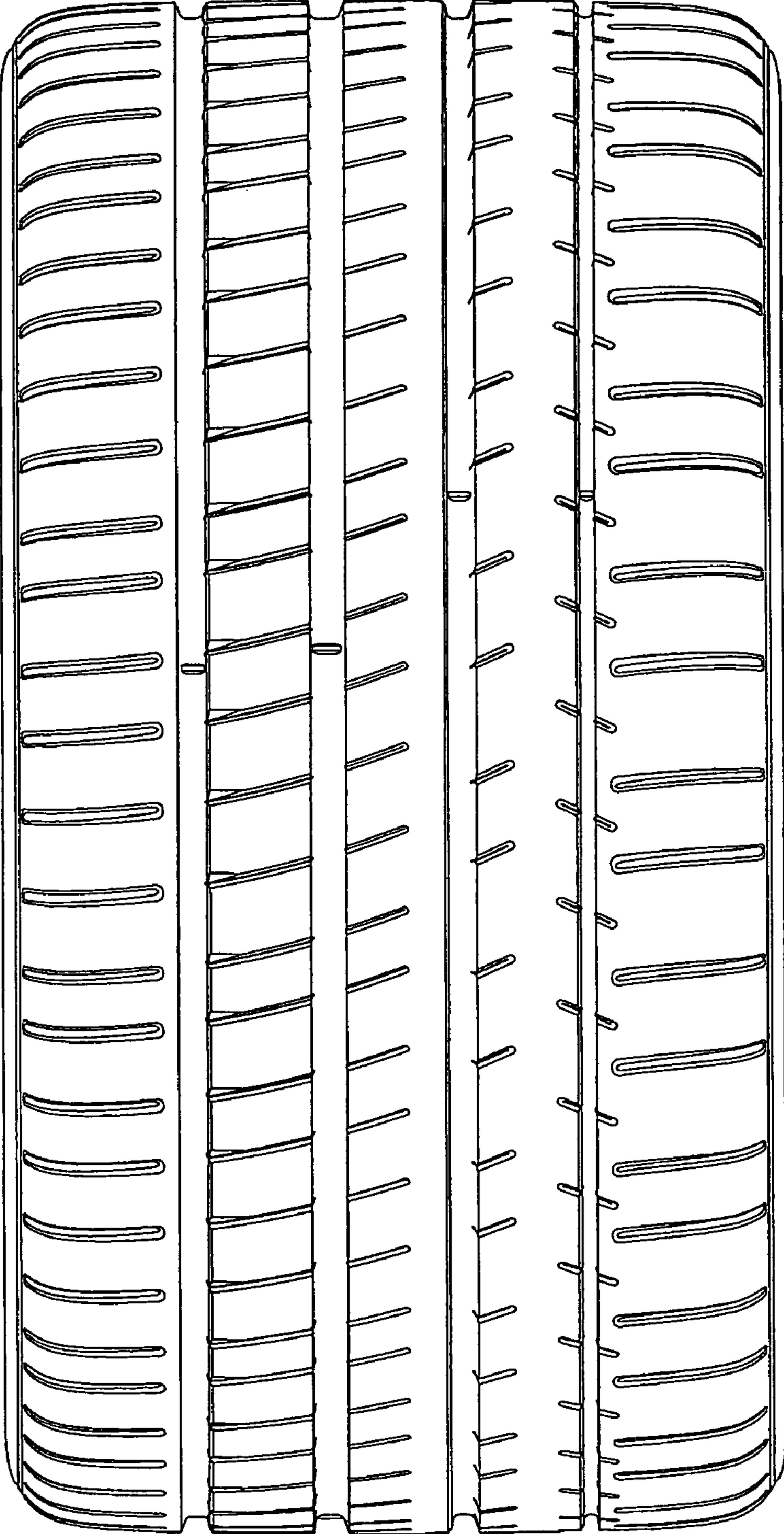

FIG. 2



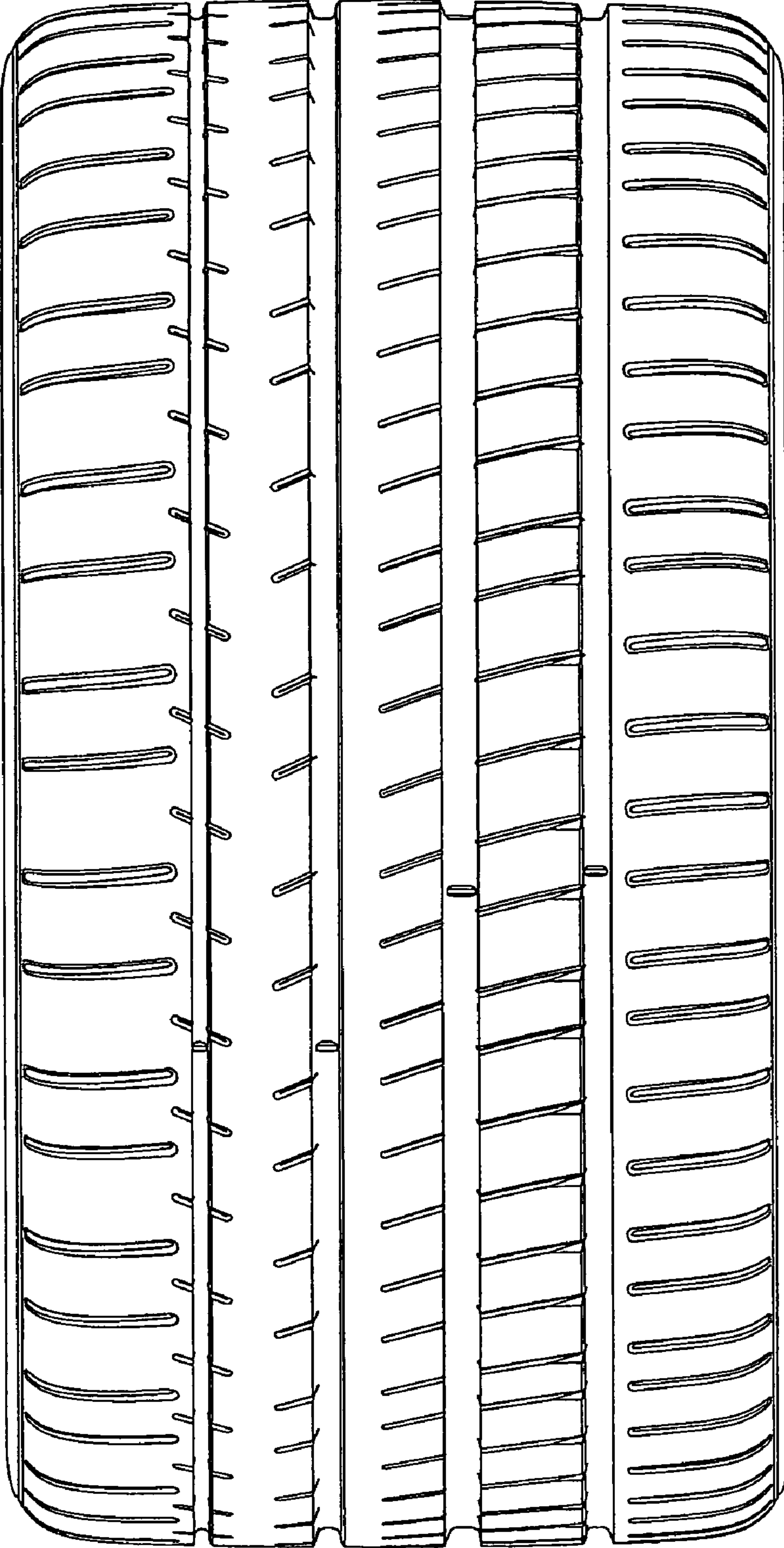

FIG. 3

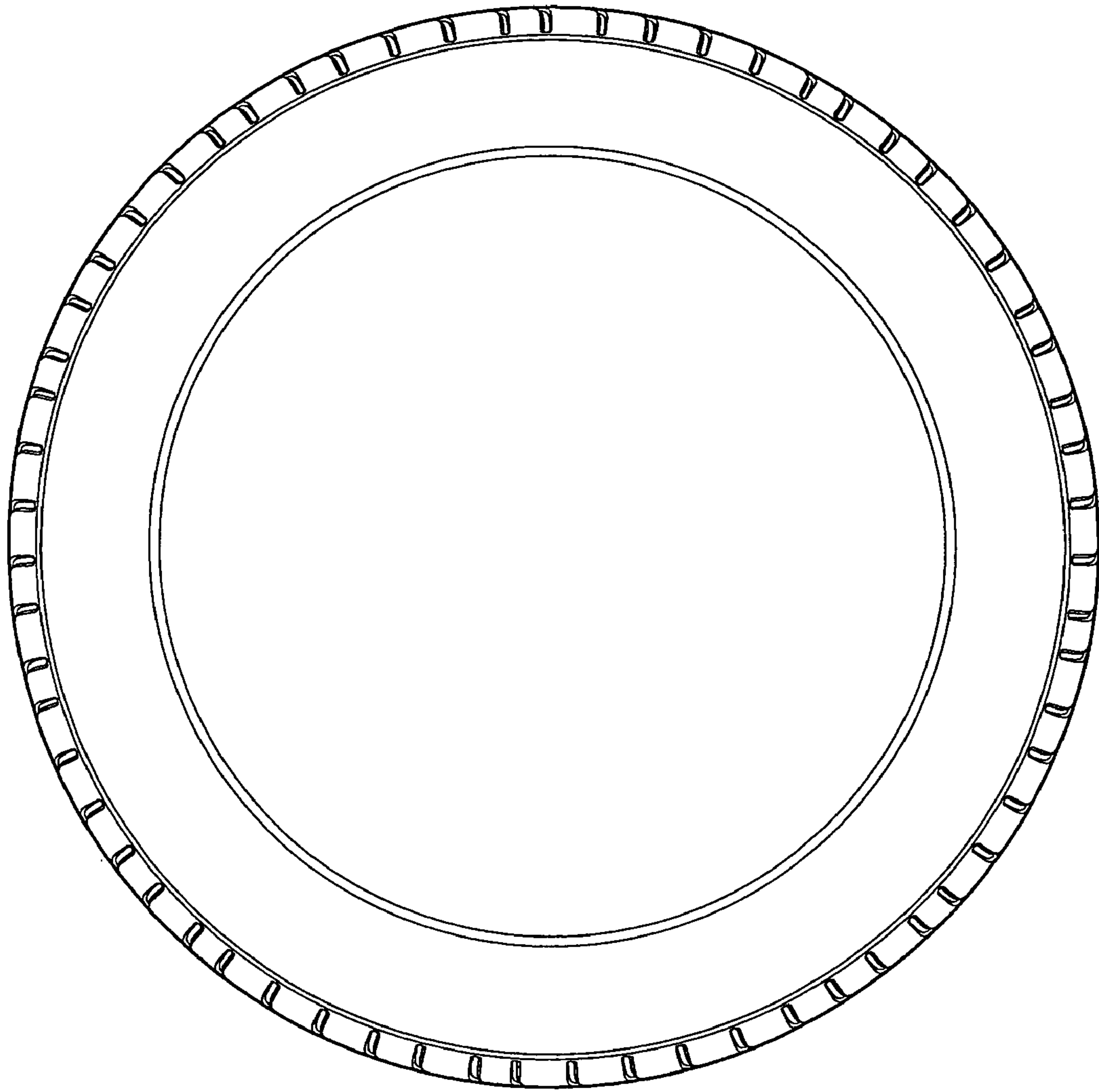

FIG. 4

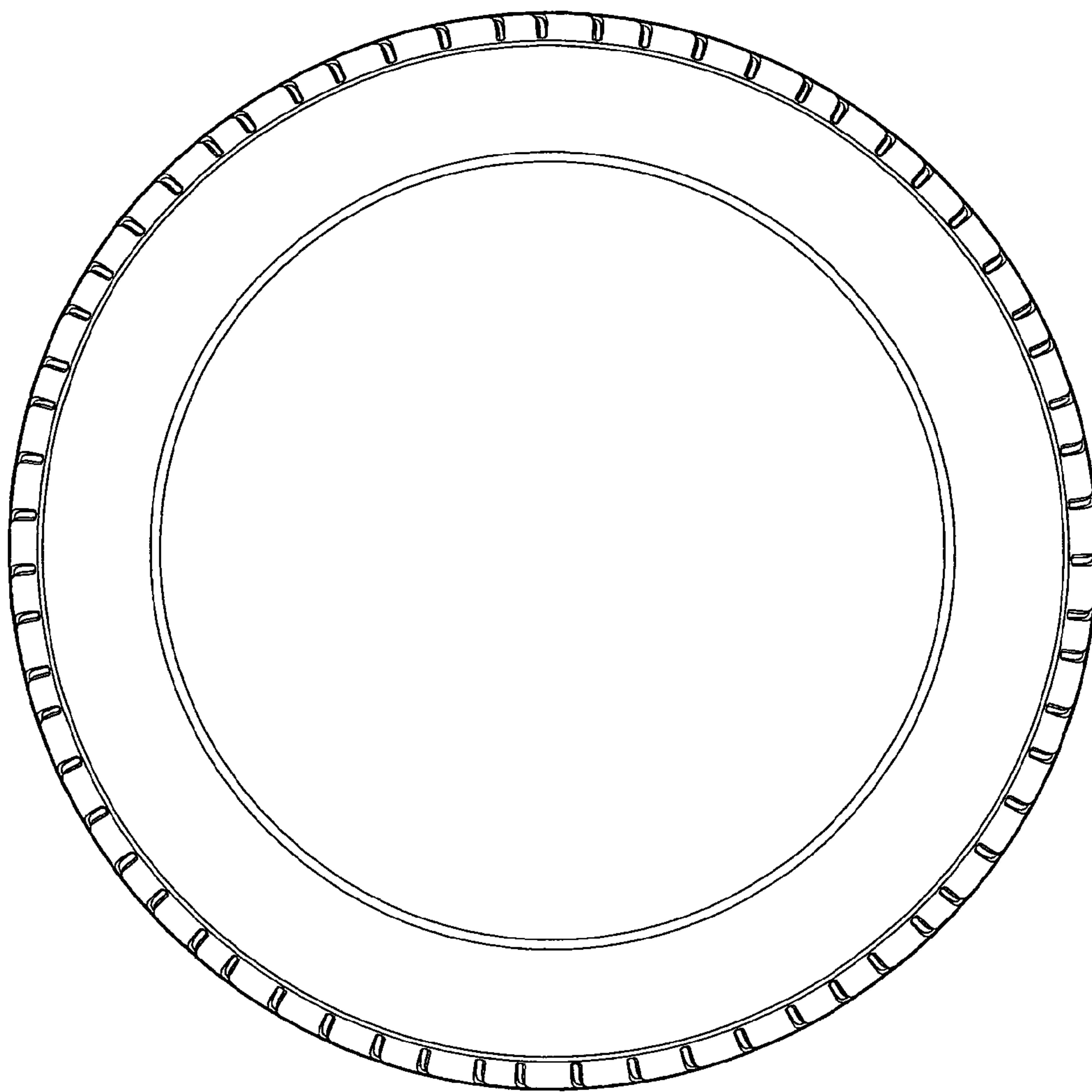

FIG. 5