



US00D609625S

(12) **United States Design Patent**
Norman

(10) **Patent No.:** **US D609,625 S**

(45) **Date of Patent:** **** Feb. 9, 2010**

(54) **MOTORCYCLE STEERING STABILIZER**

Primary Examiner—Cathron C Brooks

Assistant Examiner—Linda G. Brooks

(76) **Inventor:** **Ralph S. Norman**, 8715 Dead Stick Rd.,
San Diego, CA (US) 92154

(74) *Attorney, Agent, or Firm*—Fehr Law Firm; Thompson E. Fehr

(**) **Term:** **14 Years**

(57) **CLAIM**

(21) **Appl. No.:** **29/288,468**

I claim the ornamental design for a motorcycle steering stabilizer, as shown and described.

(22) **Filed:** **Jun. 11, 2007**

DESCRIPTION

(51) **LOC (9) Cl.** **12-11**

FIG. 1 is an isometric view from slightly above of the motorcycle steering stabilizer, showing a first side and back of the motorcycle steering stabilizer.

(52) **U.S. Cl.** **D12/218**

FIG. 2 is a lateral view of a first side of the motorcycle steering stabilizer.

(58) **Field of Classification Search** D12/110,
D12/114, 178, 218, 118, 180, 400, 117; 280/89,
280/90, 270, 272, 274–278, 288.1–288.4,
280/281.1, 833, 835; 74/555.1, 551.2, 551.8;
180/306, 310, 290, 307, 308, 218, 219; 251/209,
251/309, 284, 297

FIG. 3 is a lateral view of a second side of the motorcycle steering stabilizer.

See application file for complete search history.

FIG. 4 is a lateral view of a back of the motorcycle steering stabilizer.

(56) **References Cited**

FIG. 5 is a lateral view of a front of the motorcycle steering stabilizer.

U.S. PATENT DOCUMENTS

FIG. 6 is a plan view of the top of the motorcycle steering stabilizer; and,

4,773,514	A *	9/1988	Gustafsson	188/306
4,789,000	A *	12/1988	Aslanian	137/556
5,492,033	A *	2/1996	Hopey	74/551.1
5,516,133	A *	5/1996	Motrenec et al.	280/272
6,401,884	B2 *	6/2002	Norman et al.	188/310
6,726,232	B2 *	4/2004	Hasegawa et al.	280/272
6,802,519	B2 *	10/2004	Morgan et al.	280/272
D571,275	S *	6/2008	Norman	D12/218
7,510,063	B2 *	3/2009	Norman	188/310

FIG. 7 is a plan view of the bottom of the motorcycle steering stabilizer.

The dot-dash lines illustrate boundaries between claimed and unclaimed portions of the motorcycle steering stabilizer, and form no part of the claimed design.

* cited by examiner

1 Claim, 3 Drawing Sheets

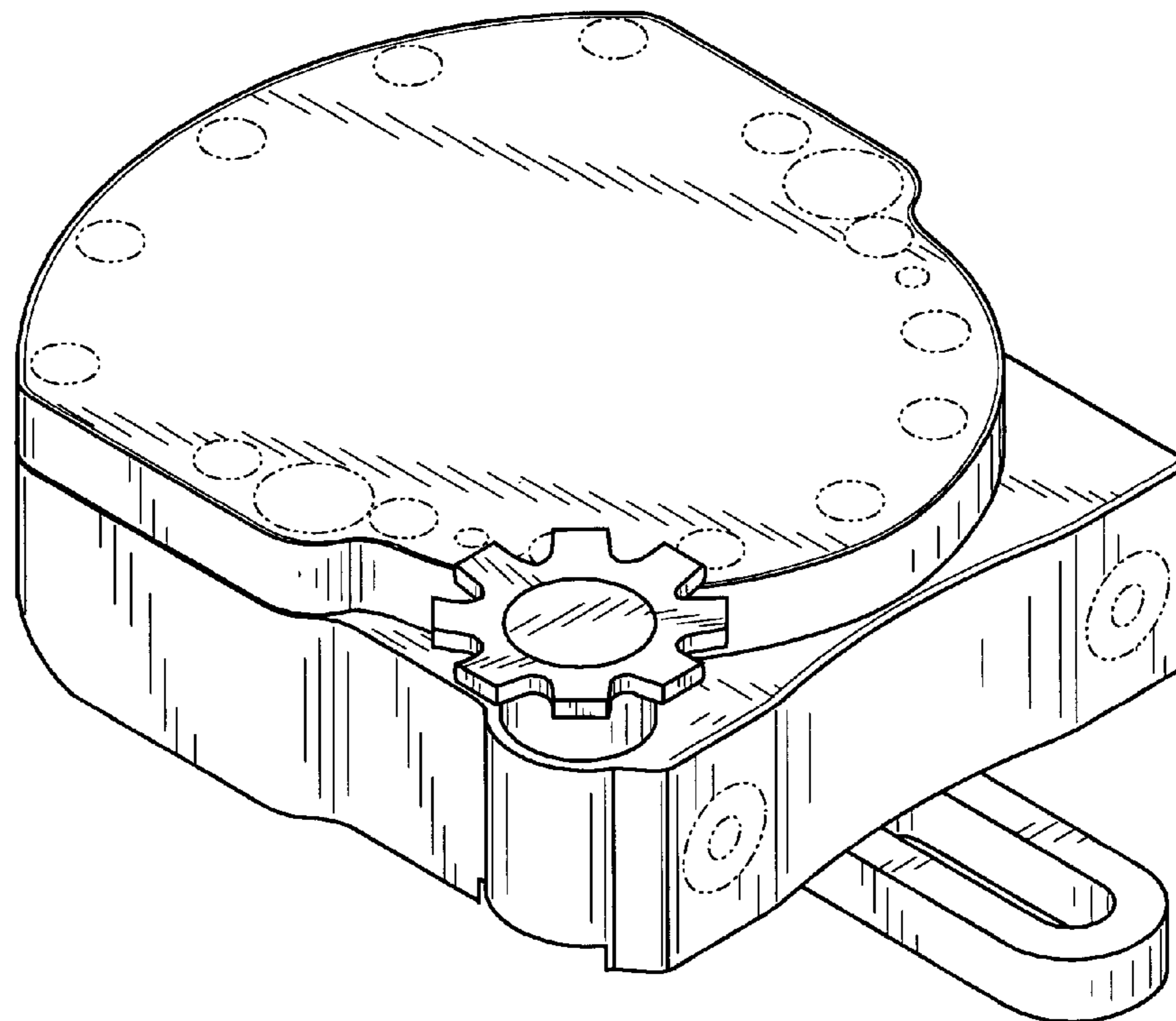

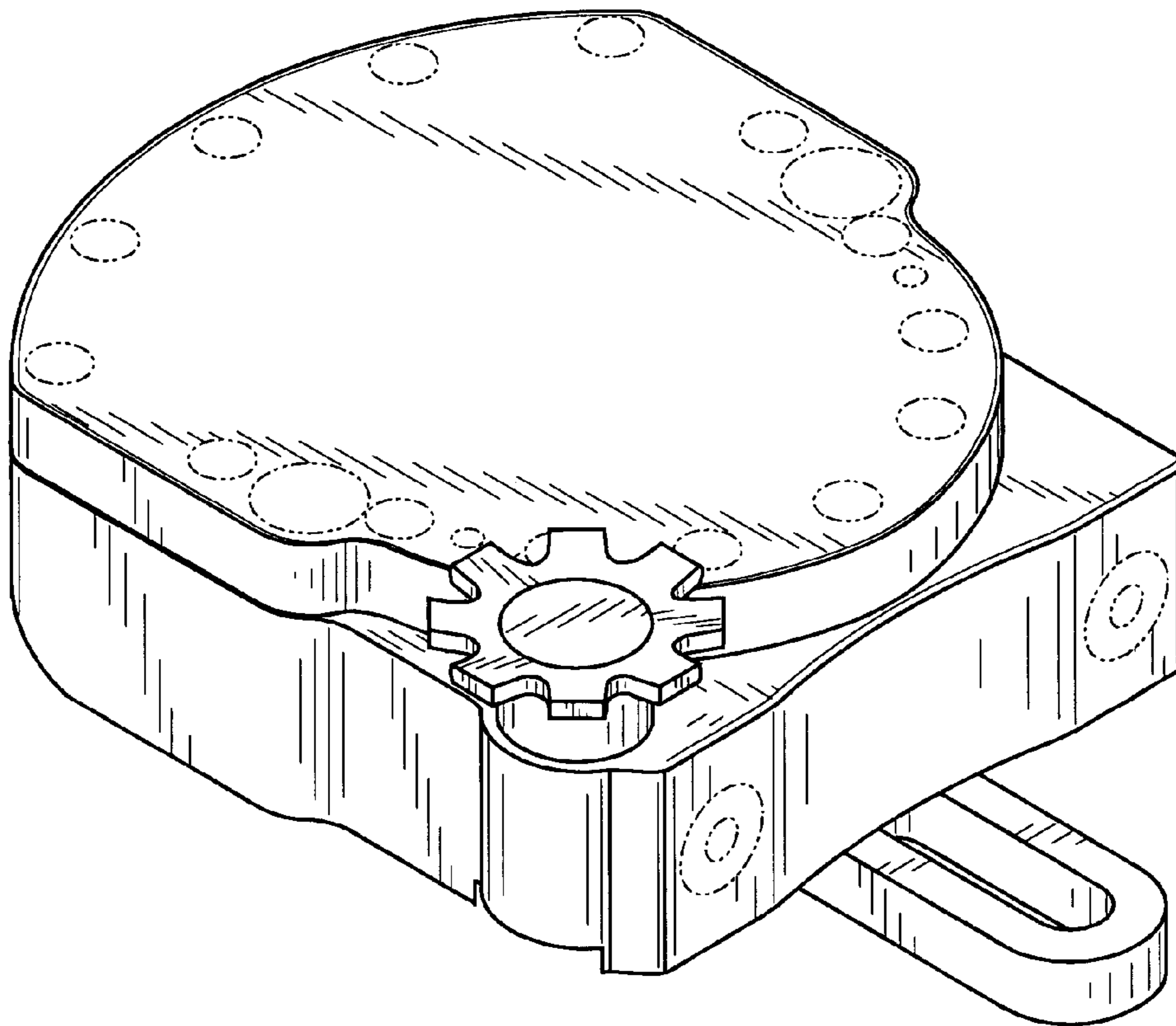

FIG. 1

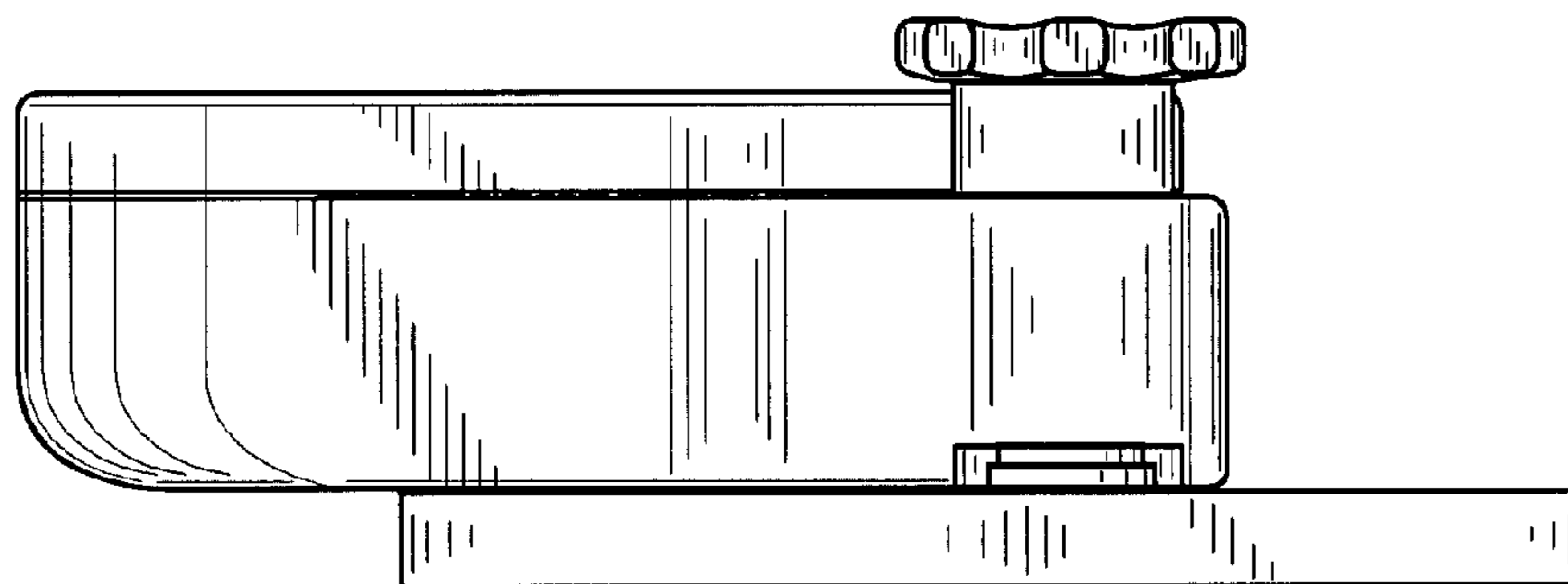

FIG. 2

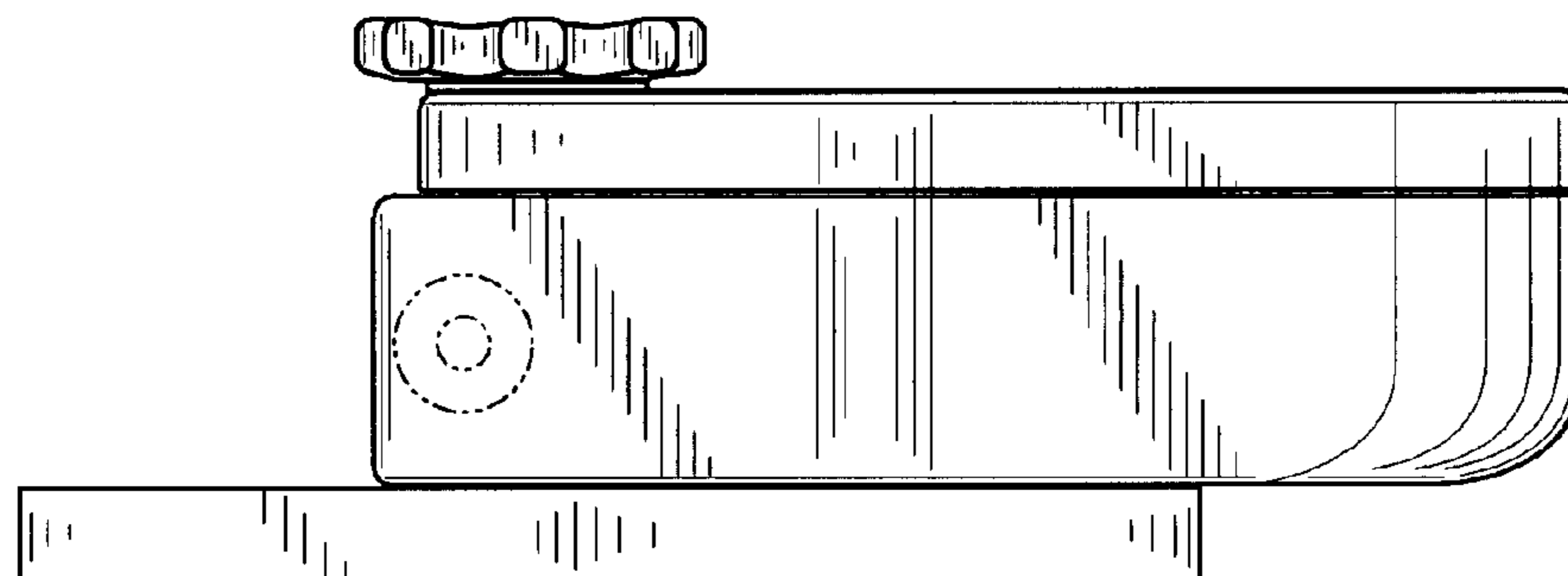

FIG. 3

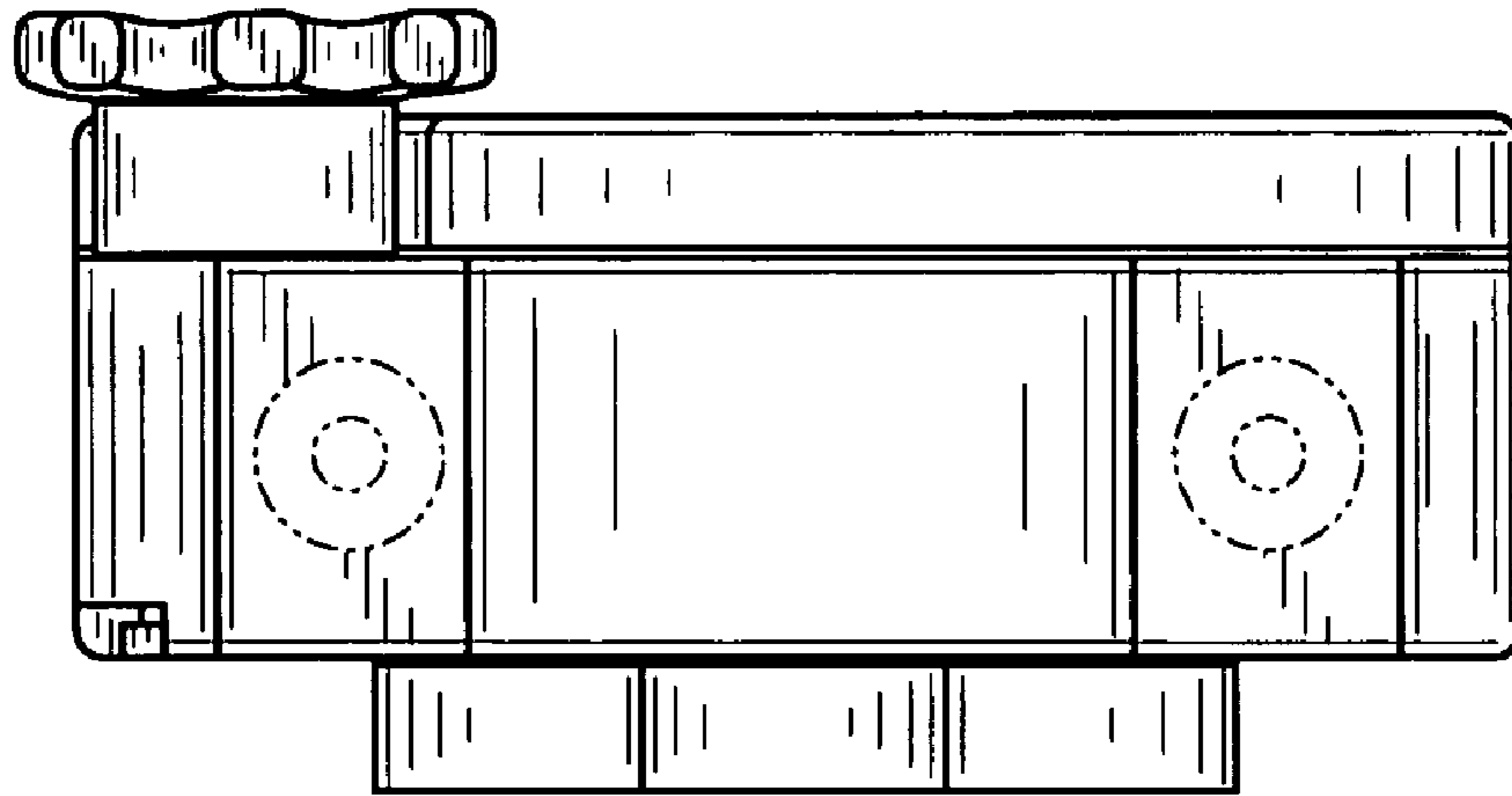

FIG. 4

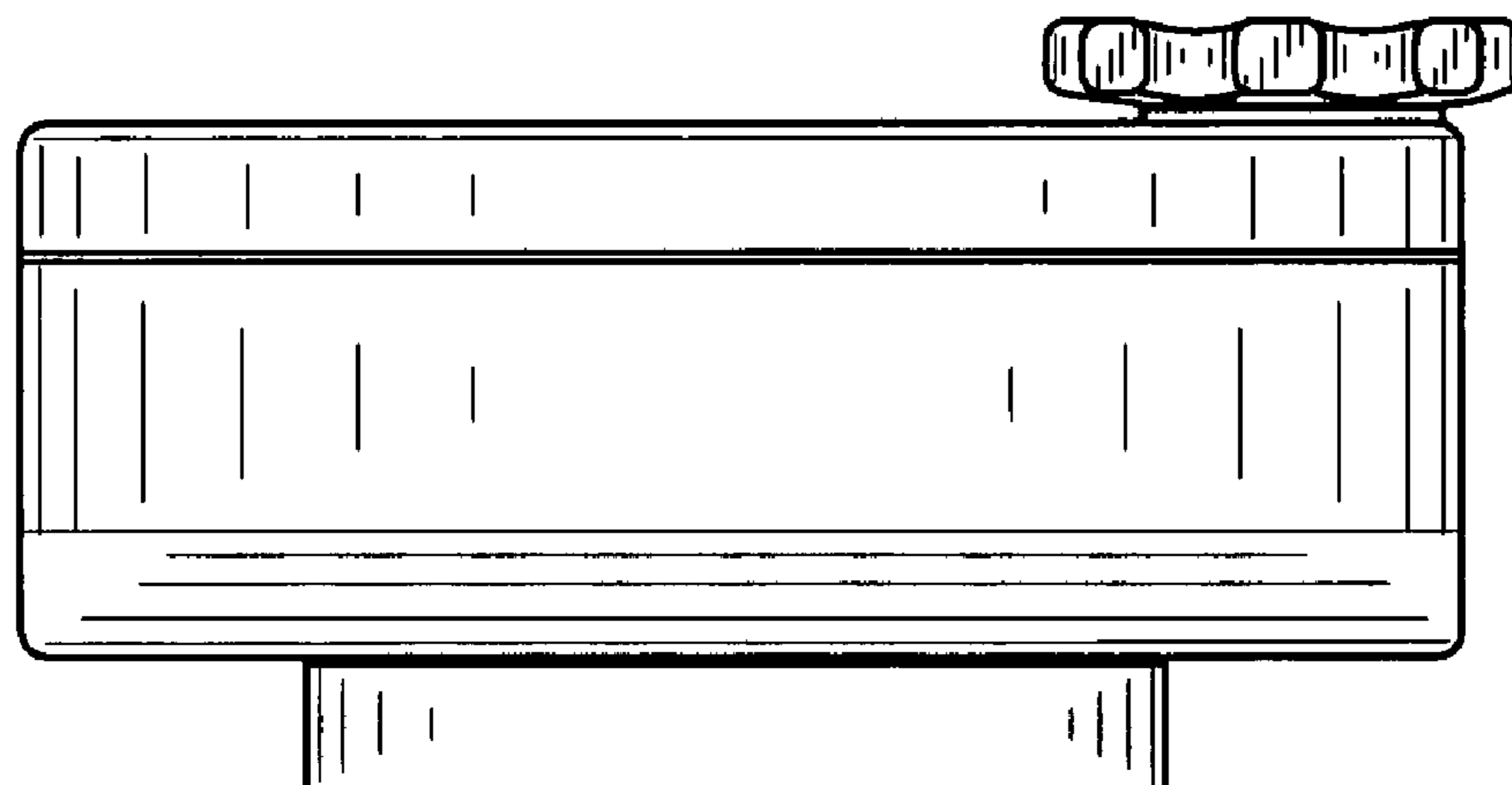

FIG. 5

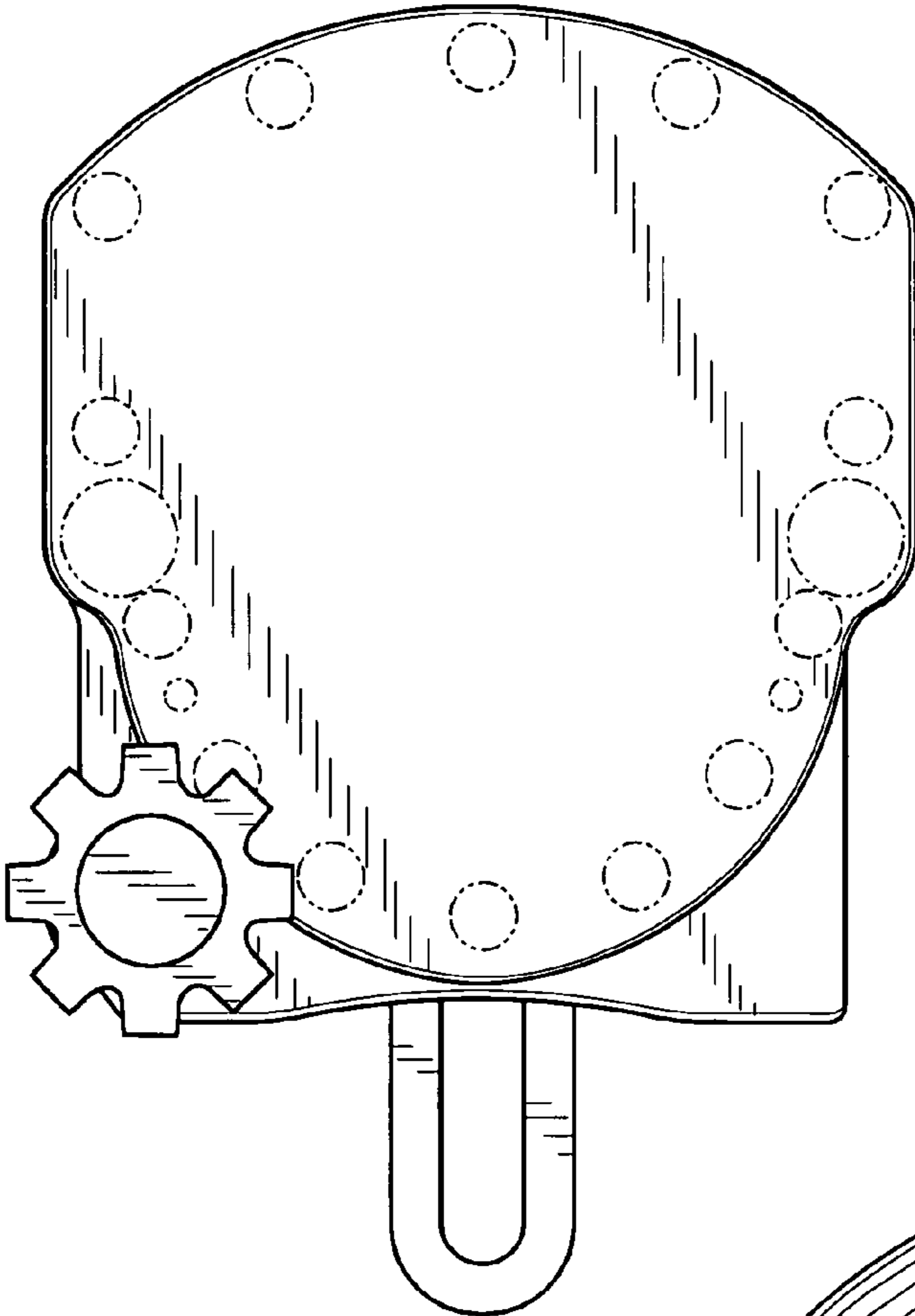

FIG. 6

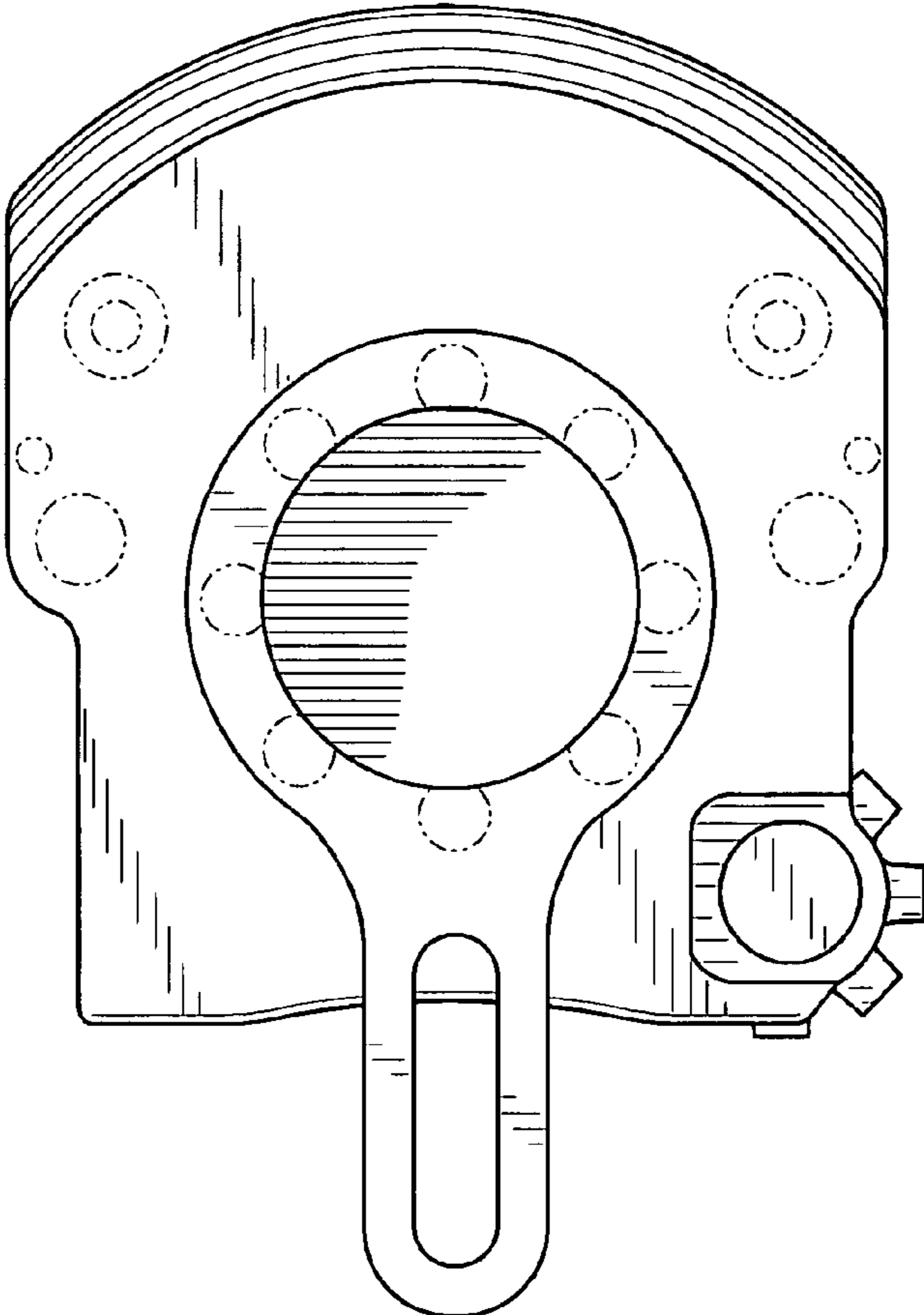

FIG. 7