



US00D609331S

(12) **United States Design Patent**  
**Paterson et al.**

(10) **Patent No.:** **US D609,331 S**

(45) **Date of Patent:** **\*\* Feb. 2, 2010**

(54) **BREAST PUMP COLLECTOR BOTTLE**

(74) *Attorney, Agent, or Firm*—Michael W. Ferrell

(75) Inventors: **Graeme L J Paterson**, Cheddar (GB);  
**Ralph J. Farrer**, Bristol (GB)

(57) **CLAIM**

(73) Assignee: **Lansinoh Laboratories**, Alexandria, VA  
(US)

The ornamental design for a breast pump collector bottle, as shown and described.

(\*\*) Term: **14 Years**

**DESCRIPTION**

(21) Appl. No.: **29/314,950**

A portion of the disclosure of this patent document contains material to which a claim for copyright is made. The copyright owner has no objection to the facsimile reproduction by anyone of the patent document or the patent disclosure as it appears in the Patent and Trademark Office patent file or records, but reserves all other copyright rights whatsoever.

(22) Filed: **May 12, 2009**

(51) **LOC (9) Cl.** ..... **24-02**

(52) **U.S. Cl.** ..... **D24/109**

(58) **Field of Classification Search** ..... D24/108–109,  
D24/231; 604/73–76

See application file for complete search history.

FIG. 1 is a perspective view of the breast pump collector bottle;

(56) **References Cited**

FIG. 2 is a front elevation of the breast pump collector bottle of FIG. 1;

**U.S. PATENT DOCUMENTS**

FIG. 3 a rear elevation of the breast pump collector bottle of FIG. 1;

D309,500	S	*	7/1990	Yuan et al.	.....	D24/109
D313,103	S	*	12/1990	Kawano	.....	D24/109
D326,319	S	*	5/1992	Chambers	.....	D24/109
D326,516	S	*	5/1992	Chambers	.....	D24/109
D420,443	S	*	2/2000	Morifuji	.....	D24/109
6,152,896	A	*	11/2000	Bachman et al.	.....	604/74
D435,906	S	*	1/2001	Wilkinson et al.	.....	D24/121
D496,097	S	*	9/2004	Rosnak et al.	.....	D24/109
D574,488	S	*	8/2008	Chauvin	.....	D24/121
D583,985	S	*	12/2008	Warden et al.	.....	D26/109

FIG. 4 is a side elevation of the breast pump collector bottle of FIG. 1;

FIG. 5 is a top plan view of the breast pump collector bottle of FIG. 1; and,

FIG. 6 is a bottom plan view of the breast pump collector bottle of FIG. 1.

\* cited by examiner

In the drawings, colored areas are shown as stippled and transparent areas are shown with oblique lines.

Preferably, the colored portions appear in Pantone 2705 or equivalent.

*Primary Examiner*—Elizabeth A Albert  
*Assistant Examiner*—Kelley A Donnelly

**1 Claim, 5 Drawing Sheets**

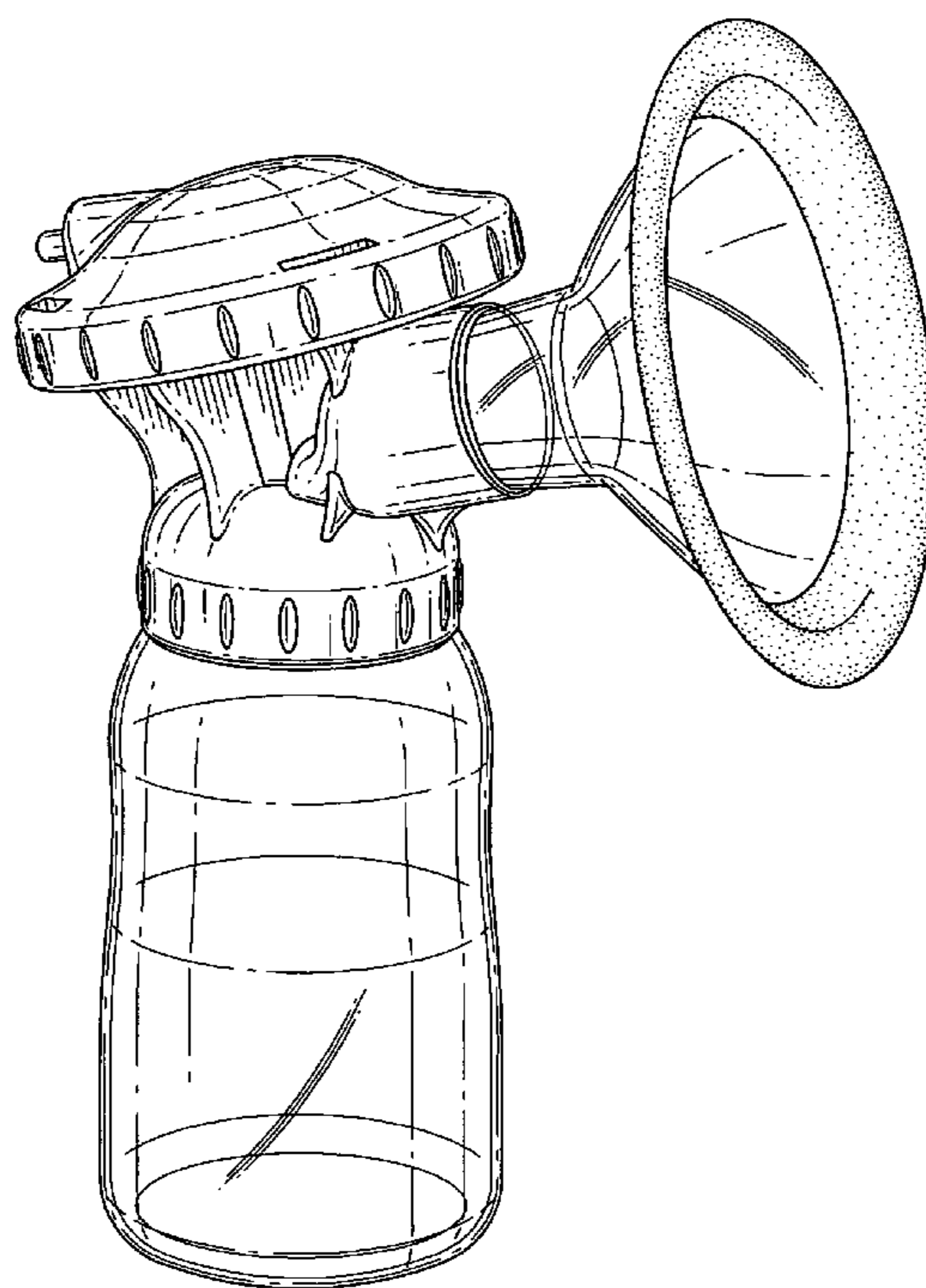
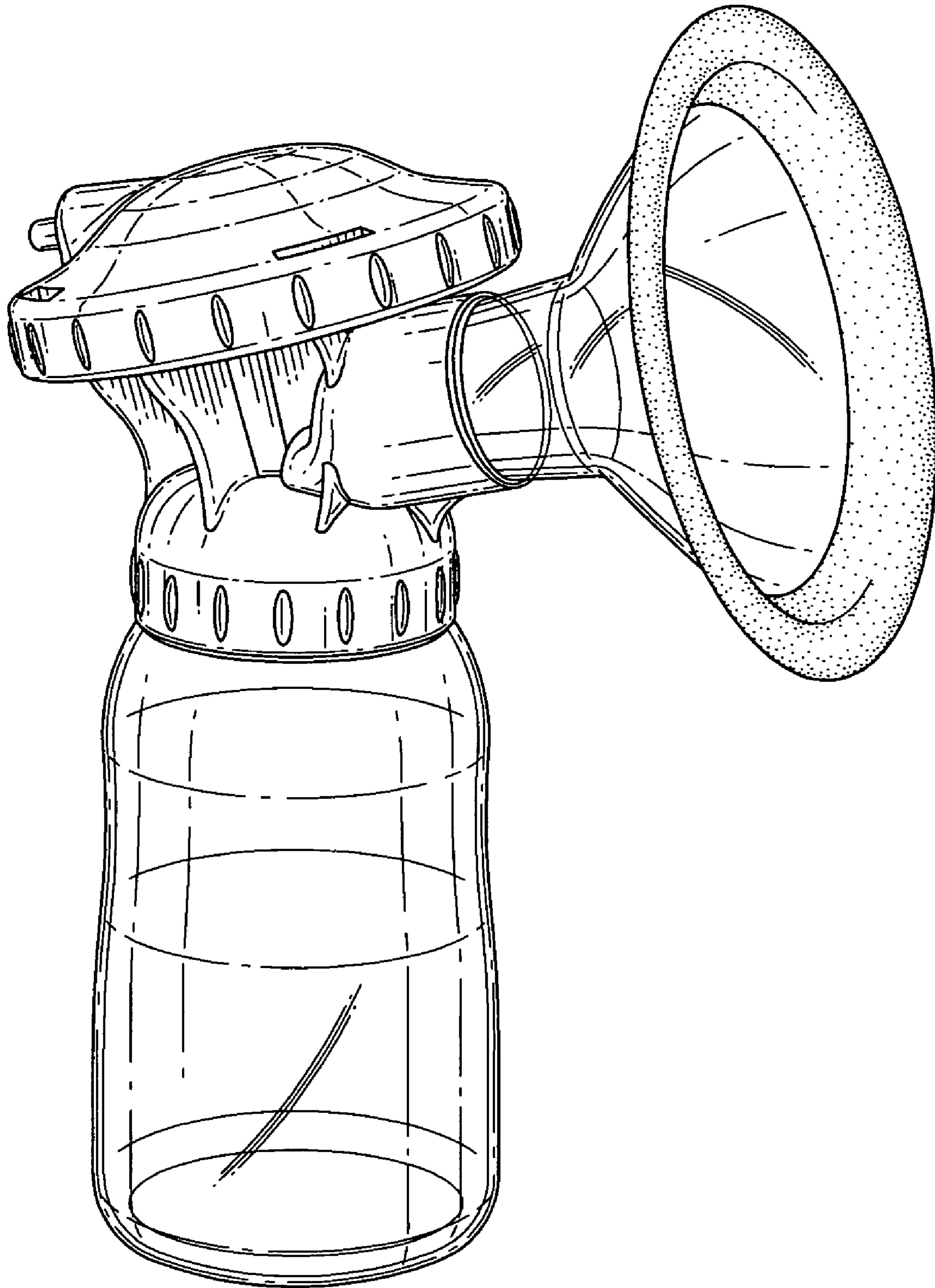
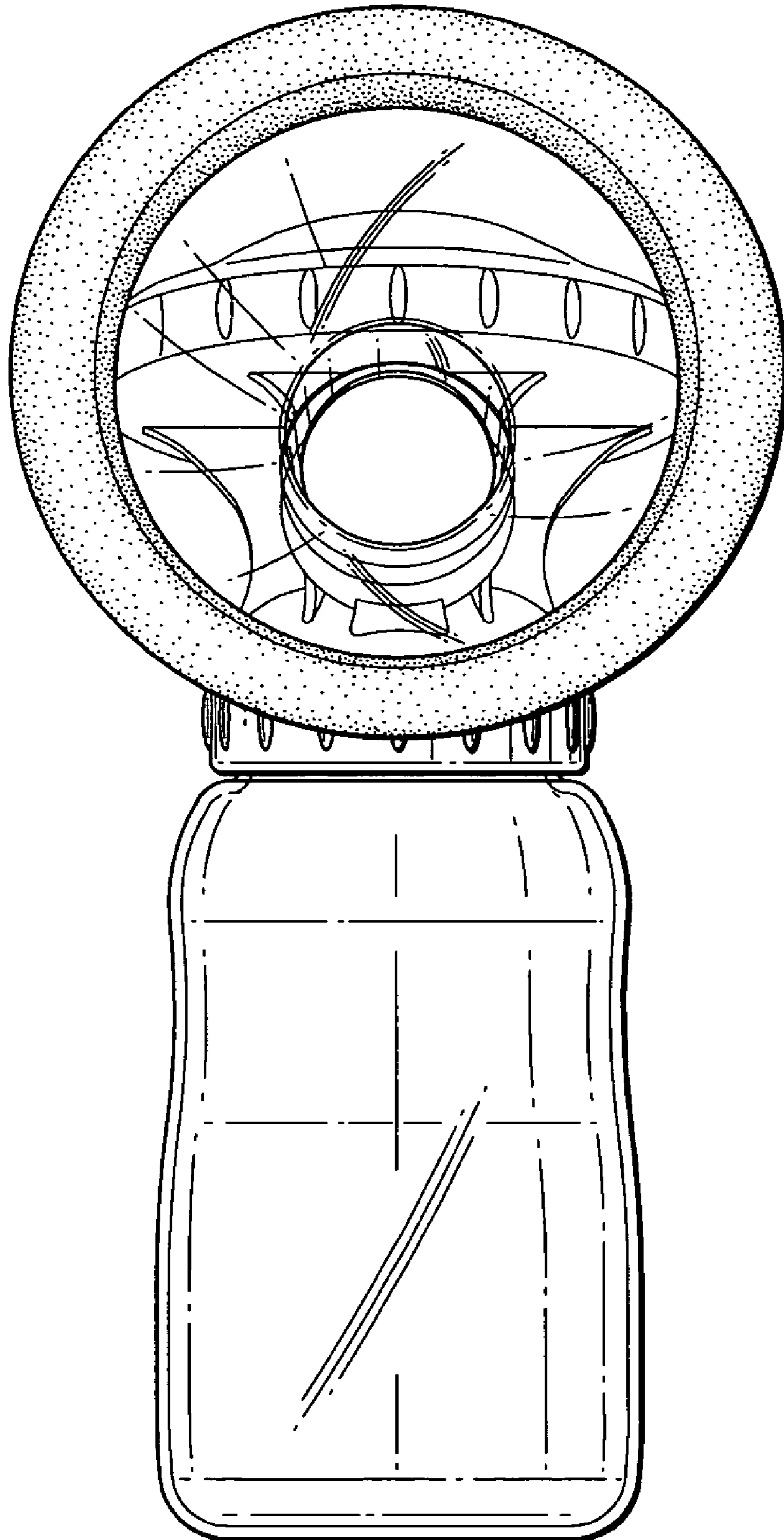

FIG. 1



**FIG. 2**



**FIG. 3**

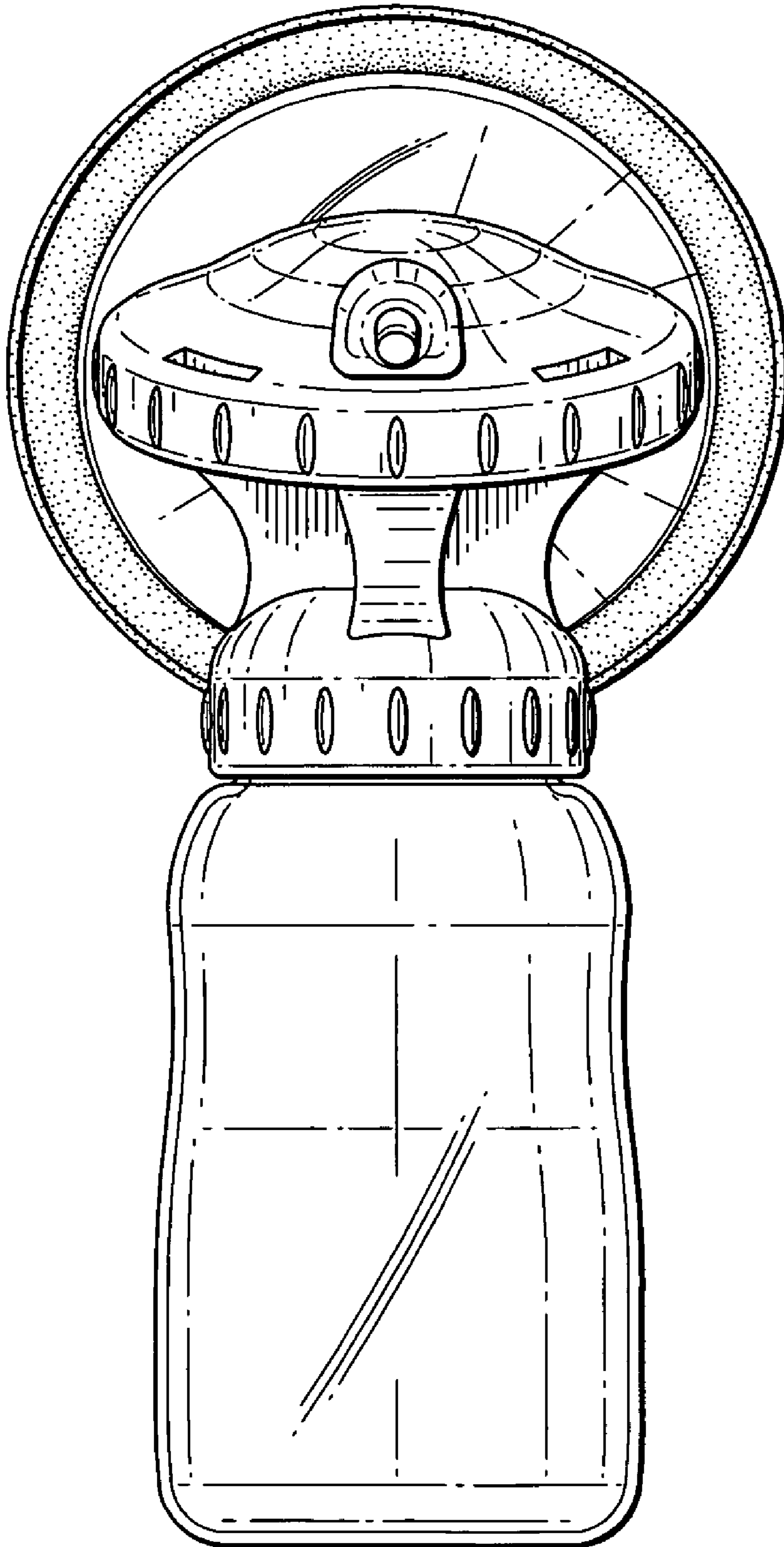

**FIG. 4**

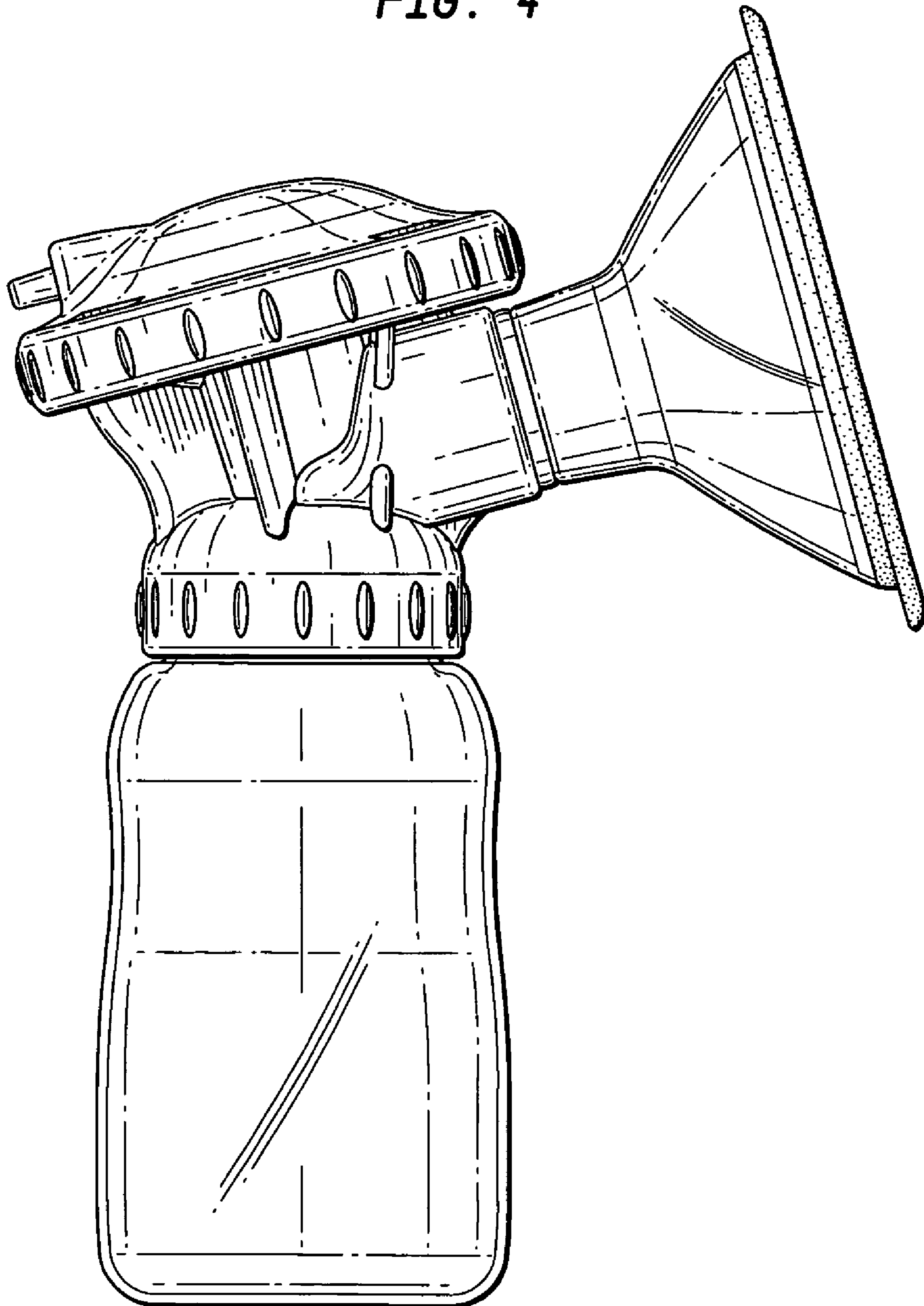

**FIG. 5**

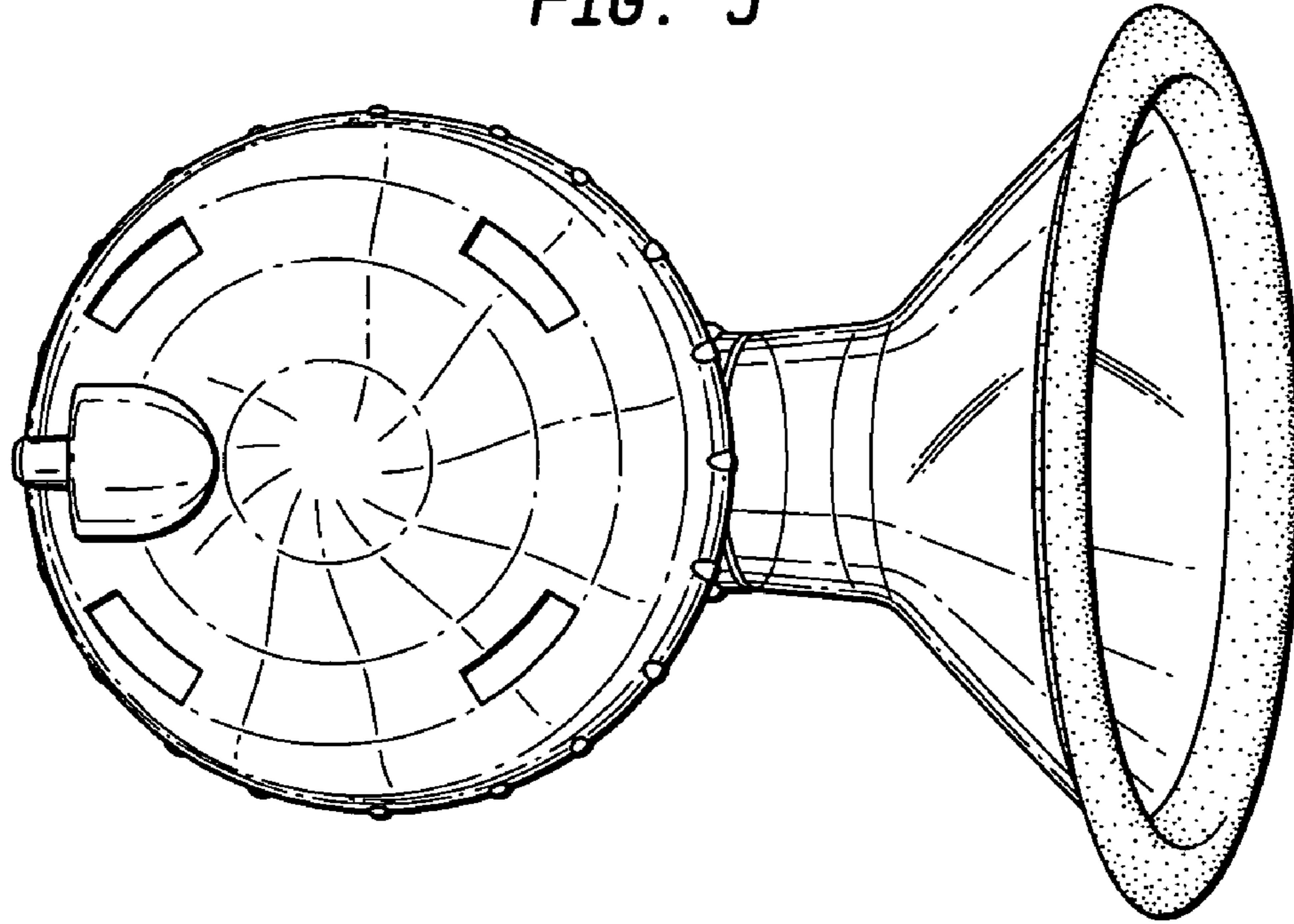

**FIG. 6**

