



US00D609330S

(12) **United States Design Patent**
Paterson et al.

(10) **Patent No.:** **US D609,330 S**

(45) **Date of Patent:** **** Feb. 2, 2010**

(54) **BREAST PUMP AND COLLECTOR BOTTLE ENSEMBLE**

(75) Inventors: **Graeme L J Paterson**, Cheddar (GB);
Ralph J. Farrer, Bristol (GB)

(73) Assignee: **Celanese International Corporation**,
Dallas, TX (US)

(**) Term: **14 Years**

(21) Appl. No.: **29/314,946**

(22) Filed: **May 12, 2009**

(51) **LOC (9) Cl.** **24-02**

(52) **U.S. Cl.** **D24/109**

(58) **Field of Classification Search** D24/108–109,
D24/231; 604/73–76; D9/455, 517, 719,
D9/738–740, 744, 751

See application file for complete search history.

(56) **References Cited**

U.S. PATENT DOCUMENTS

D309,500 S *	7/1990	Yuan et al.	D24/109
D313,103 S *	12/1990	Kawano	D24/109
D326,319 S *	5/1992	Chambers	D24/109
D326,516 S *	5/1992	Chambers	D24/109
D420,443 S *	2/2000	Morifuji	D24/109
6,152,896 A *	11/2000	Bachman et al.	604/74
D435,906 S *	1/2001	Wilkinson et al.	D24/121
D496,097 S *	9/2004	Rosnak et al.	D24/109
D524,789 S *	7/2006	Beasley et al.	D14/149
D528,979 S *	9/2006	Franck et al.	D13/108
D530,302 S *	10/2006	Franck et al.	D14/149
D533,834 S *	12/2006	Liu	D13/133
D563,619 S *	3/2008	Palese et al.	D32/58
D566,041 S *	4/2008	Stratford	D13/108
D574,488 S *	8/2008	Chauvin	D24/121
D583,985 S *	12/2008	Warden et al.	D26/109
D596,247 S *	7/2009	Wu	D21/694

* cited by examiner

Primary Examiner—Elizabeth A Albert
Assistant Examiner—Kelley A Donnelly
(74) *Attorney, Agent, or Firm*—Michael W. Ferrell

(57) **CLAIM**

The ornamental design for a breast pump and collector bottle ensemble, as shown and described.

DESCRIPTION

A portion of the disclosure of this patent document contains material to which a claim for copyright is made. The copyright owner has no objection to the facsimile reproduction by anyone of the patent document or the patent disclosure as it appears in the Patent and Trademark Office patent file or records, but reserves all other copyright rights whatsoever.

FIG. 1 is a perspective of the breast pump and collector bottle ensemble;

FIG. 2 a front elevation of the breast pump and collector bottle ensemble of FIG. 1;

FIG. 3 is a rear elevation of the breast pump and collector bottle ensemble of FIG. 1;

FIG. 4 is a right side elevation of the breast pump and collector bottle ensemble of FIG. 1;

FIG. 5 is a left side elevation of the breast pump and collector bottle ensemble of FIG. 1; and,

FIG. 6 is a top plan view of the breast pump and collector bottle ensemble of FIG. 1.

In the drawings, the colored areas on the funnel portions are shown as stippled and transparent areas on the funnels and bottles are indicated with oblique lines.

Preferably, the colored portions appear in Pantone 2705 or equivalent and the pump base is of the same or similar color.

The broken lines are for environmental purposes only and form no part of the claimed design.

1 Claim, 6 Drawing Sheets

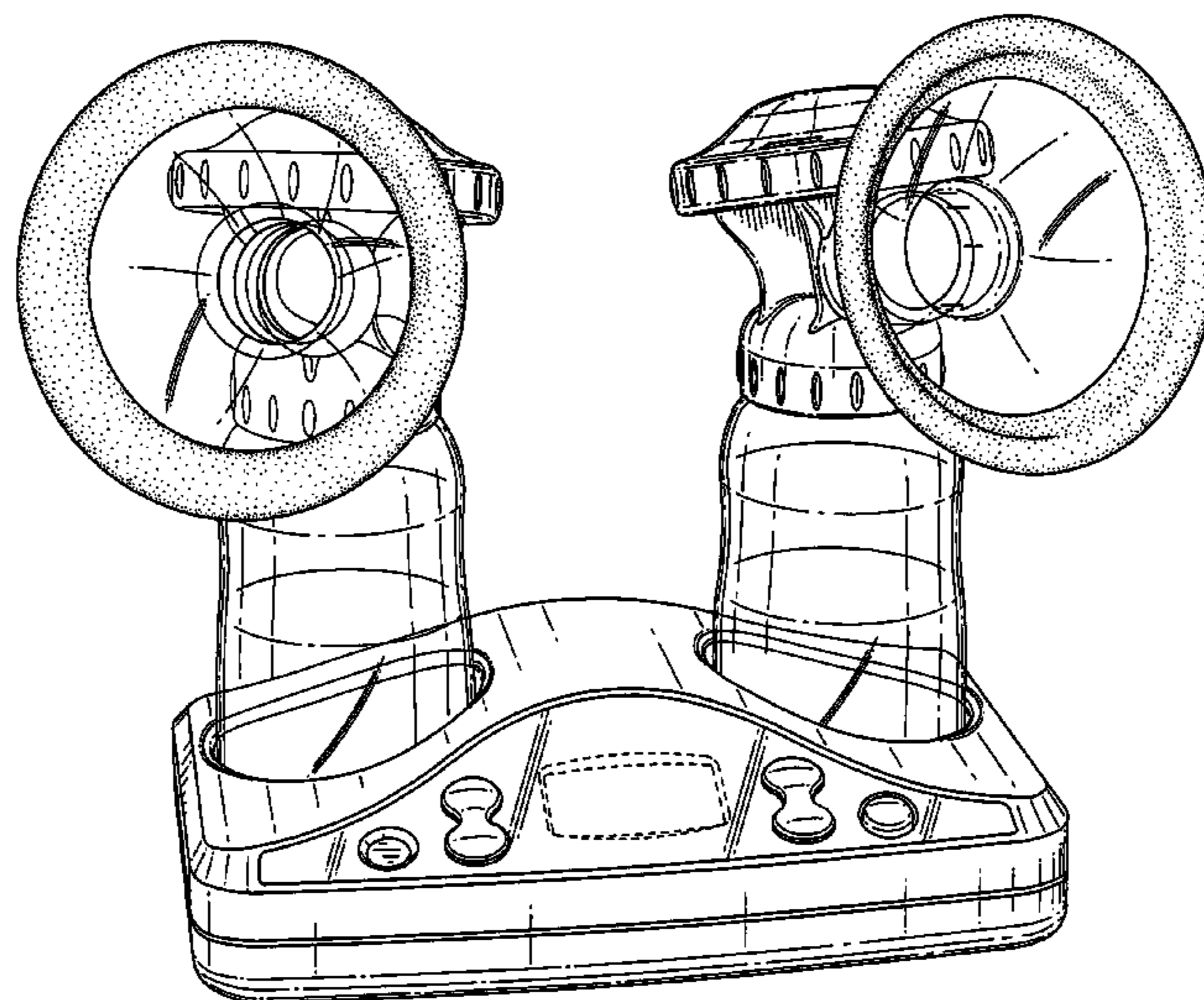

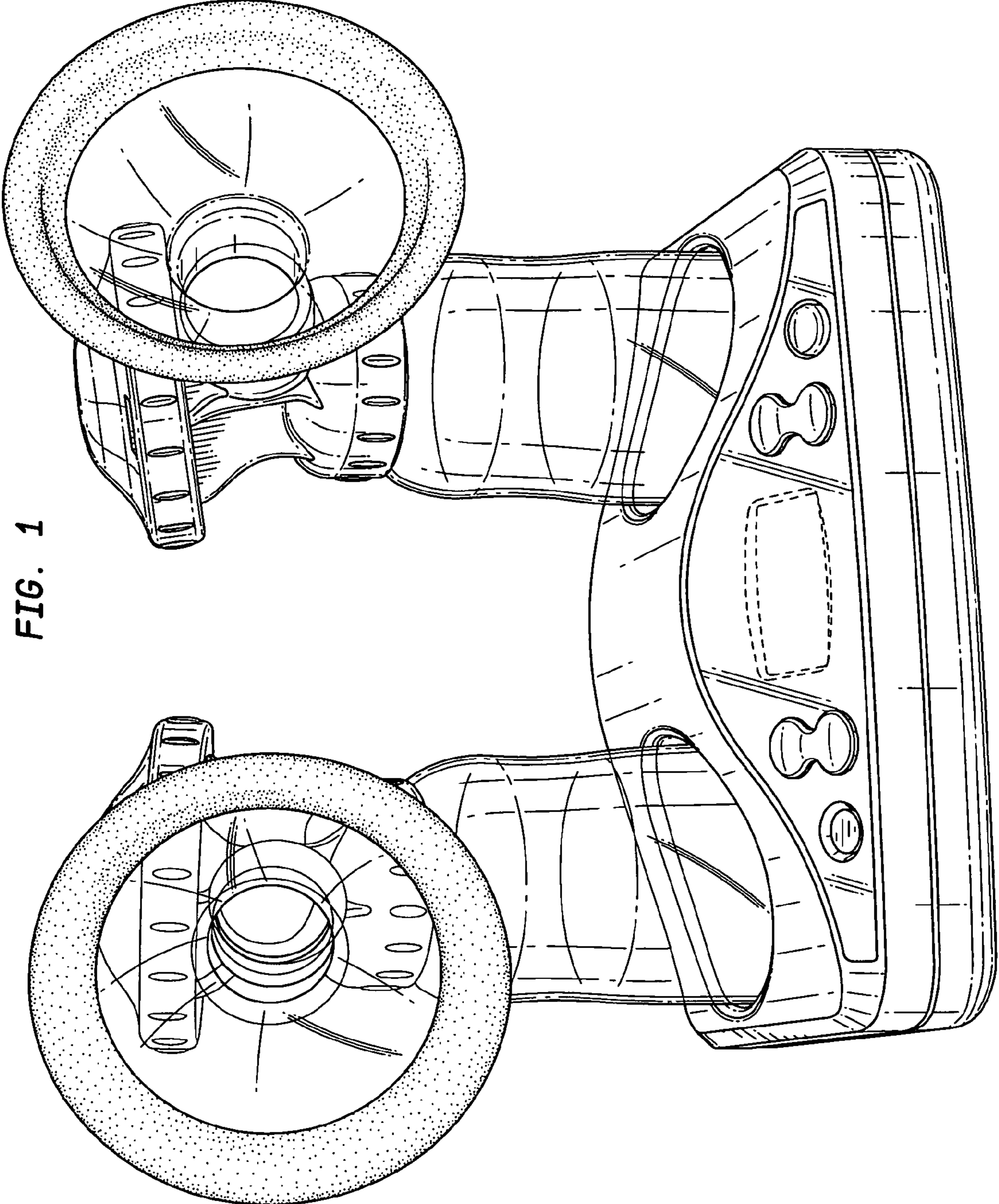

FIG. 1

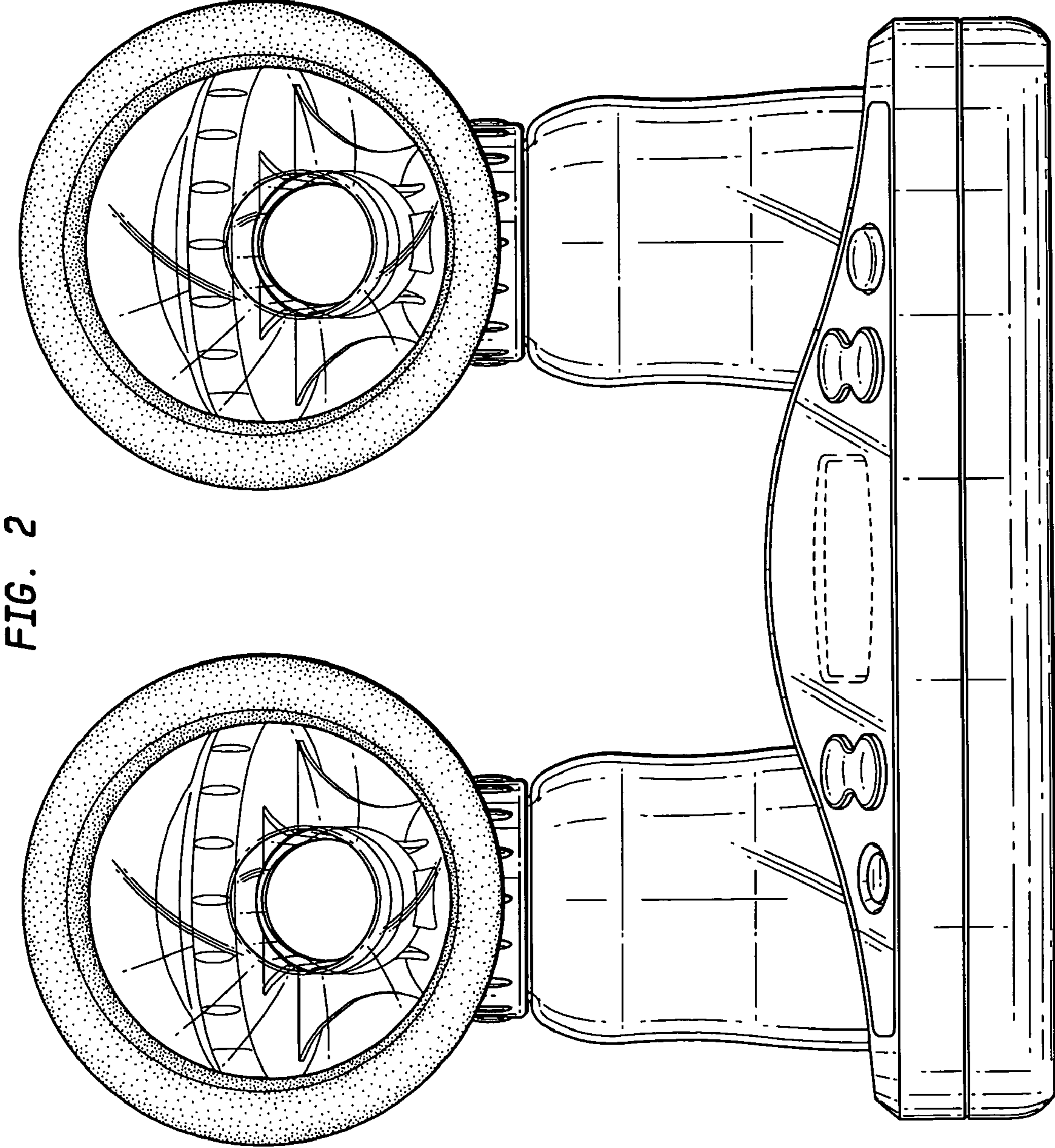

FIG. 2

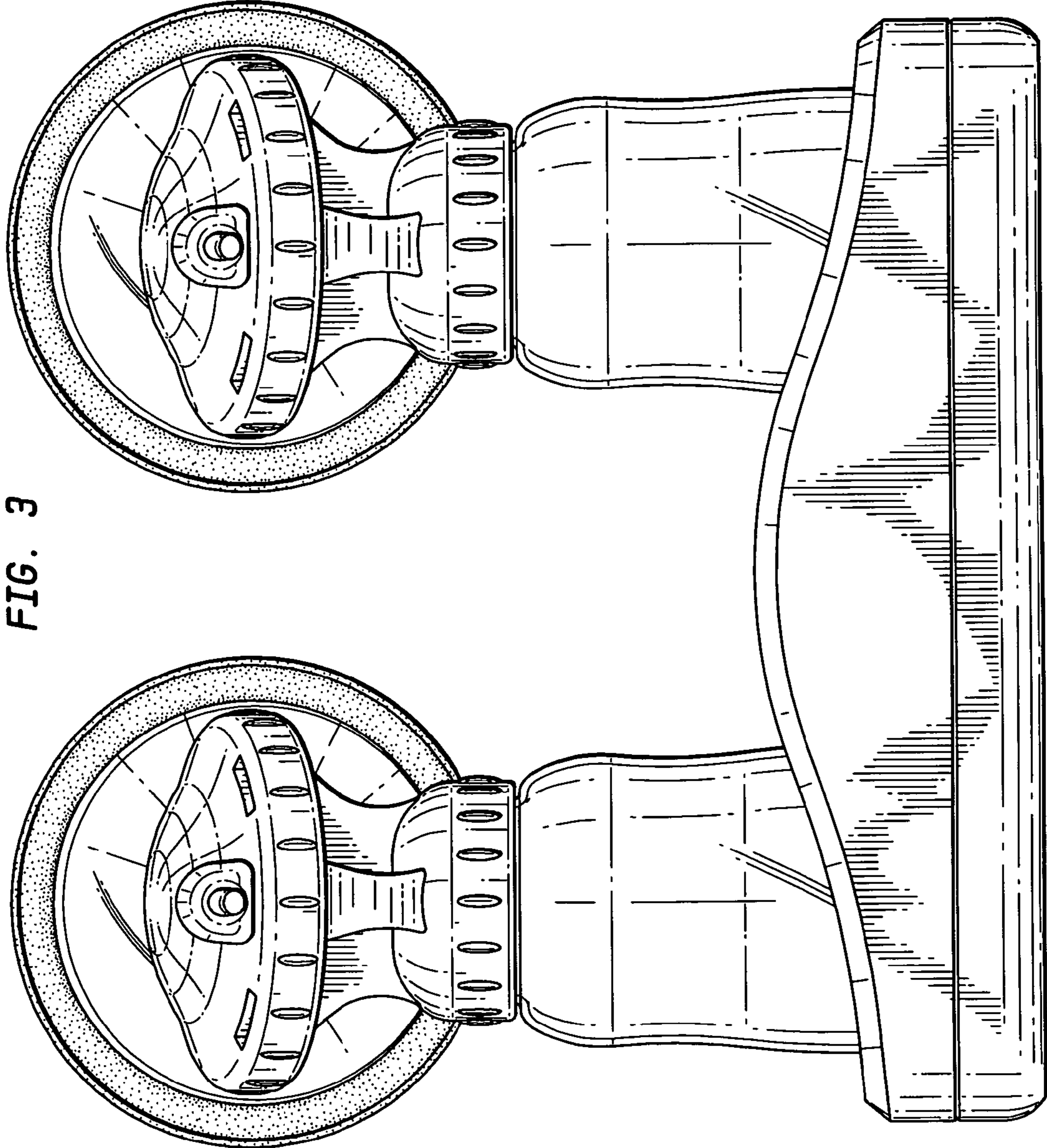

FIG. 3

FIG. 4

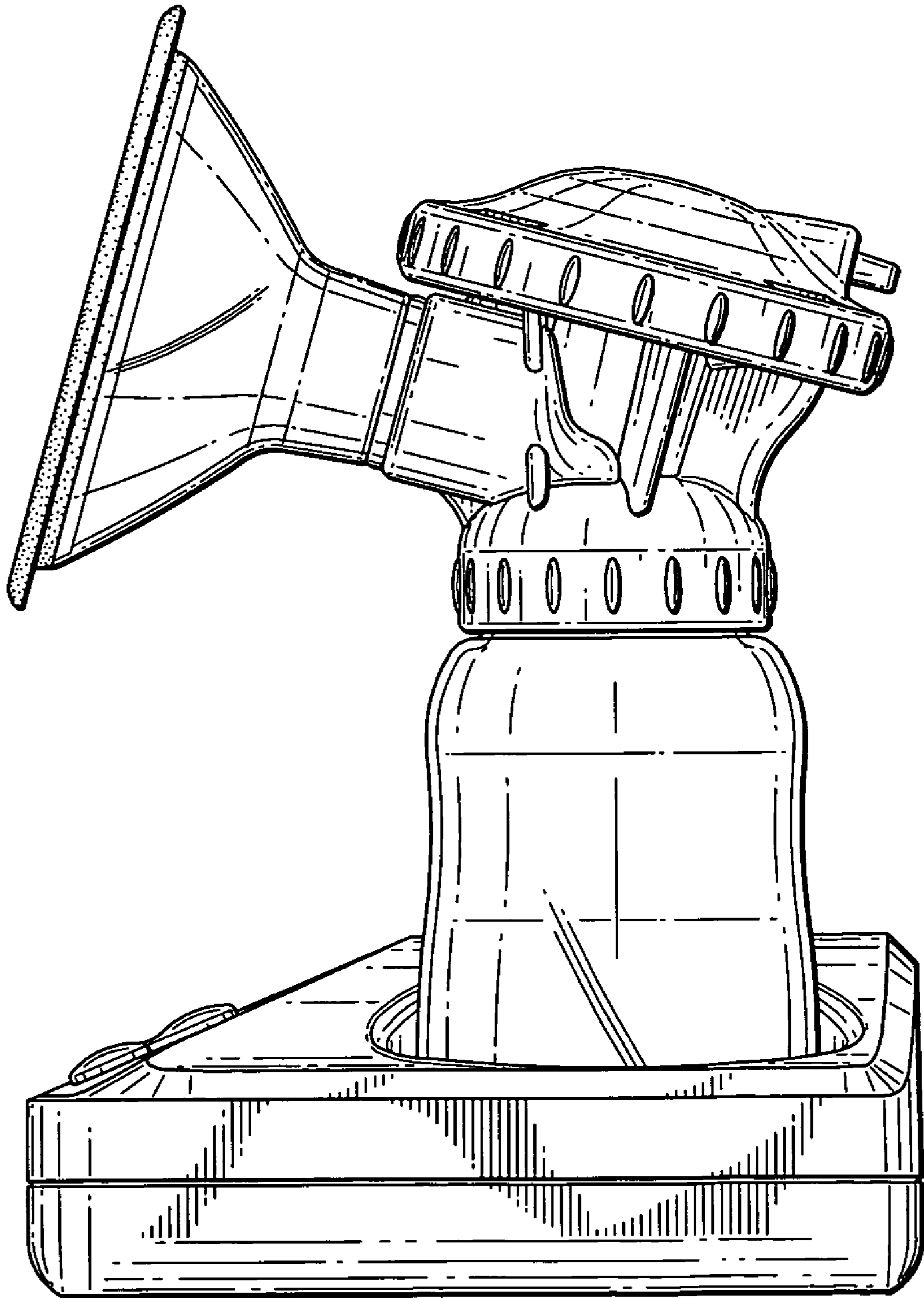

FIG. 5

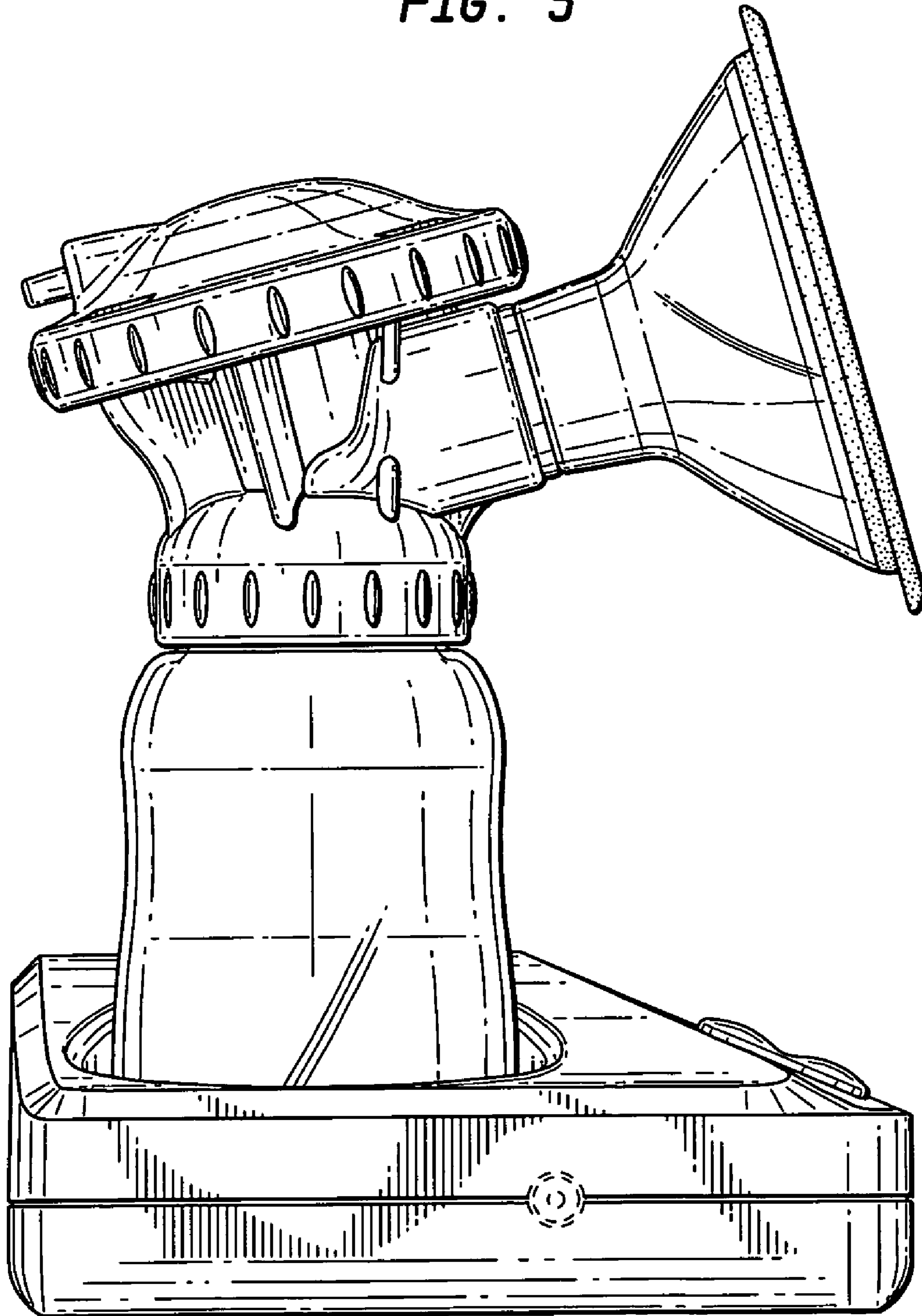

FIG. 6

