



US00D609294S

(12) **United States Design Patent**
Oldknow

(10) **Patent No.:** **US D609,294 S**

(45) **Date of Patent:** **** Feb. 2, 2010**

(54) **GOLF CLUB HEAD**

(75) Inventor: **Andrew G. V. Oldknow**, Beaverton, OR
(US)

(73) Assignee: **NIKE, Inc.**, Beaverton, OR (US)

(**) Term: **14 Years**

(21) Appl. No.: **29/346,797**

(22) Filed: **Nov. 5, 2009**

(51) **LOC (9) Cl.** **21-02**

(52) **U.S. Cl.** **D21/759**

(58) **Field of Classification Search** D21/733,
D21/752, 759; 473/324–331, 343–346
See application file for complete search history.

(56) **References Cited**

U.S. PATENT DOCUMENTS

D316,583 S	4/1991	Mahaffey et al.	
D318,891 S	8/1991	Duclos	
5,203,565 A	4/1993	Murray et al.	
5,547,188 A	8/1996	Dumontier et al.	
D379,391 S	5/1997	Moore	
D383,818 S	9/1997	Williams, Jr.	
D385,003 S	10/1997	Burrows	
D390,294 S	2/1998	Burrows	
D390,295 S	2/1998	Burrows	
D390,616 S	2/1998	Maltby	
5,720,674 A	2/1998	Galy	
D396,512 S	7/1998	Besnard et al.	
D397,749 S	9/1998	Burrows	
D398,681 S	9/1998	Galy	
D398,682 S	9/1998	Moore	
D401,299 S	11/1998	Burrows	
D403,037 S	12/1998	Stone et al.	
D411,600 S	6/1999	Antonious	
D413,642 S	9/1999	Burrows	
D413,953 S	9/1999	Burrows	
5,971,867 A	10/1999	Galy	
5,989,134 A	11/1999	Antonious	
D417,478 S	12/1999	Nagahama et al.	
D422,327 S *	4/2000	Takaoka et al.	D21/733
D426,268 S *	6/2000	Ortiz	D21/752

6,102,813 A	8/2000	Dill	
D433,073 S *	10/2000	Sodano	D21/752
D438,583 S	3/2001	O'Doherty et al.	
D444,522 S	7/2001	Crousore	
6,257,991 B1	7/2001	Ortiz	
D458,325 S	6/2002	Antonious	
D463,516 S	9/2002	Antonious	
6,530,847 B1	3/2003	Antonious	
D502,232 S	2/2005	Antonious	
6,855,068 B2	2/2005	Antonious	
6,860,818 B2	3/2005	Mahaffey et al.	
6,890,267 B2	5/2005	Mahaffey et al.	
6,988,960 B2 *	1/2006	Mahaffey et al.	473/345

(Continued)

OTHER PUBLICATIONS

Taylor Made Ti Bubble 2 Woods and Burner Bubble Woods, Edwin Watts Catalog, Late Summer 1998, pp. 8 and 9.

(Continued)

Primary Examiner—Mitchell I Siegel
(74) *Attorney, Agent, or Firm*—Banner & Witcoff, Ltd.

(57) **CLAIM**

The ornamental design for a golf club head, as shown and described.

DESCRIPTION

FIG. 1 is a bottom perspective view of a golf club head showing my new design;
FIG. 2 is a bottom view thereof;
FIG. 3 is a rear view thereof;
FIG. 4 is a toe-end view thereof;
FIG. 5 is a heel-end view thereof;
FIG. 6 is a front view thereof; and,
FIG. 7 is a top view thereof.

The broken line showing of the remainder of the golf club head is for environmental purposes only and forms no part of the claimed design.

1 Claim, 4 Drawing Sheets

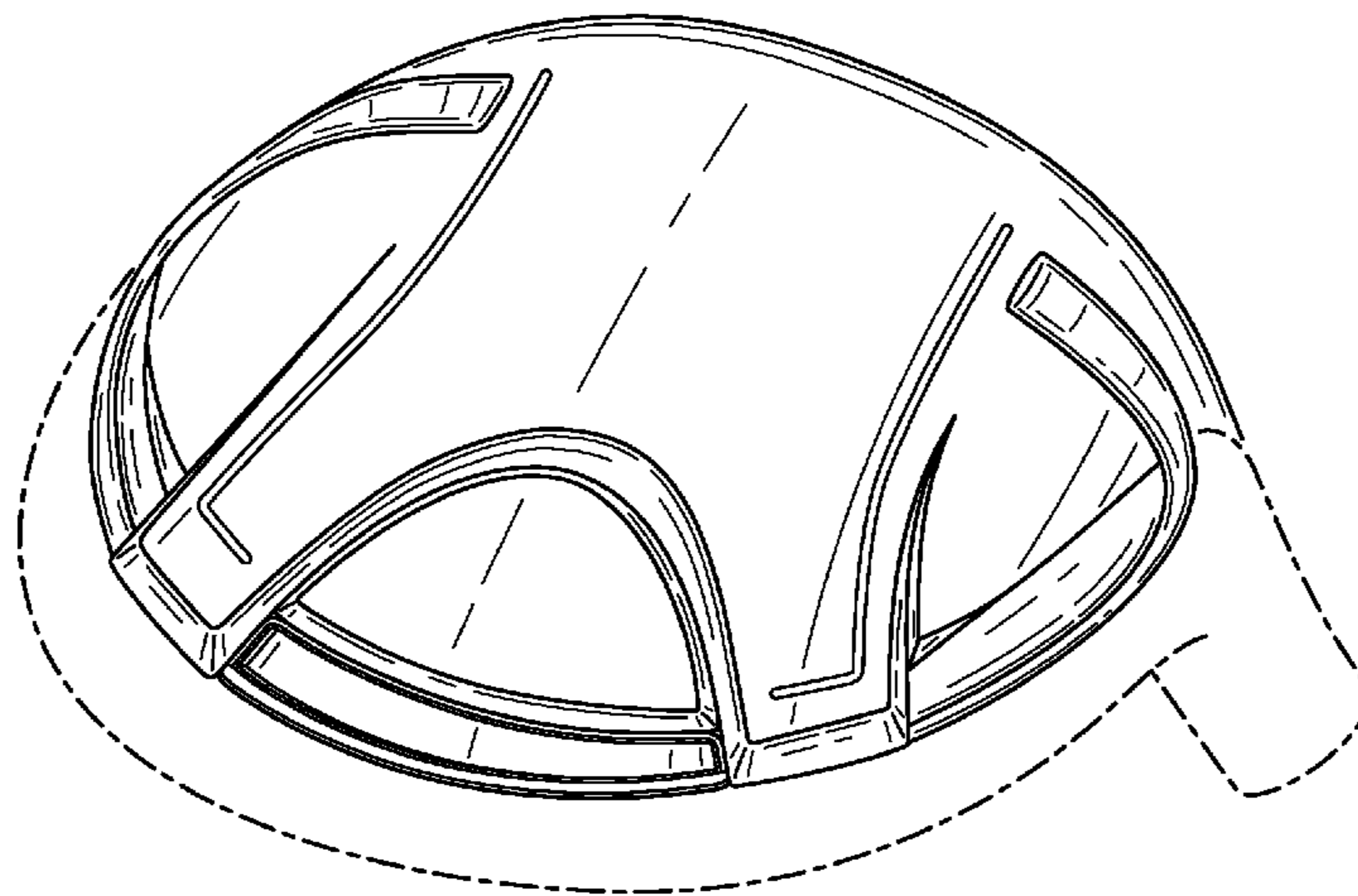

US D609,294 S

Page 2

U.S. PATENT DOCUMENTS

D516,147 S 2/2006 Imamoto
D523,498 S * 6/2006 Chen et al. D21/733
D531,244 S 10/2006 Gilbert et al.
D532,068 S 11/2006 Tang et al.
D538,369 S 3/2007 Gilbert et al.
D541,363 S 4/2007 Gilbert et al.
D550,800 S * 9/2007 Ruggiero et al. D21/759
D561,284 S * 2/2008 Nagai et al. D21/759
D564,611 S * 3/2008 Llewellyn et al. D21/759
D564,612 S 3/2008 Oldknow et al.
D565,137 S 3/2008 Oldknow et al.
D565,141 S 3/2008 Oldknow et al.
D565,142 S 3/2008 Oldknow et al.
D572,324 S 7/2008 Chen et al.
D574,049 S 7/2008 Kadoya
D578,174 S 10/2008 Tang et al.
D578,588 S 10/2008 Oldknow et al.
D578,591 S 10/2008 Oldknow et al.
D588,223 S 3/2009 Kuan
D589,105 S * 3/2009 Oldknow D21/759

D589,106 S * 3/2009 Oldknow D21/759
D589,107 S * 3/2009 Oldknow D21/759
D589,108 S * 3/2009 Oldknow D21/759
D595,370 S 6/2009 Ines et al.
D599,870 S 9/2009 Serrano et al.
D600,295 S 9/2009 Meeks
D600,762 S 9/2009 Serrano et al.

OTHER PUBLICATIONS

Lynx Black Cat Series, Edwin Watts Catalog, Late Summer 1998, p. 23.
AVDP XLS Metal Woods, Edwin Watts Catalog, Summer 1998, p. 24.
Players Offset Woods, Players Brochure, p. 2. Date unknown but prior to filing date of the current application.
Golfsmith Cermet 2000 Driver Head, Golfsmith Catalog, 1998, p. 49.
Nicklaus Dual Point Fastback Drivers, Austad's Golf Catalog, Spring 2008, p. 16.
Nickent Hybrids, Austad's Golf Catalog, Spring 2008, p. 17.
Harvey Penick Plus Driver Head, Harvey Penick Catalog 1997, p. 8.

* cited by examiner

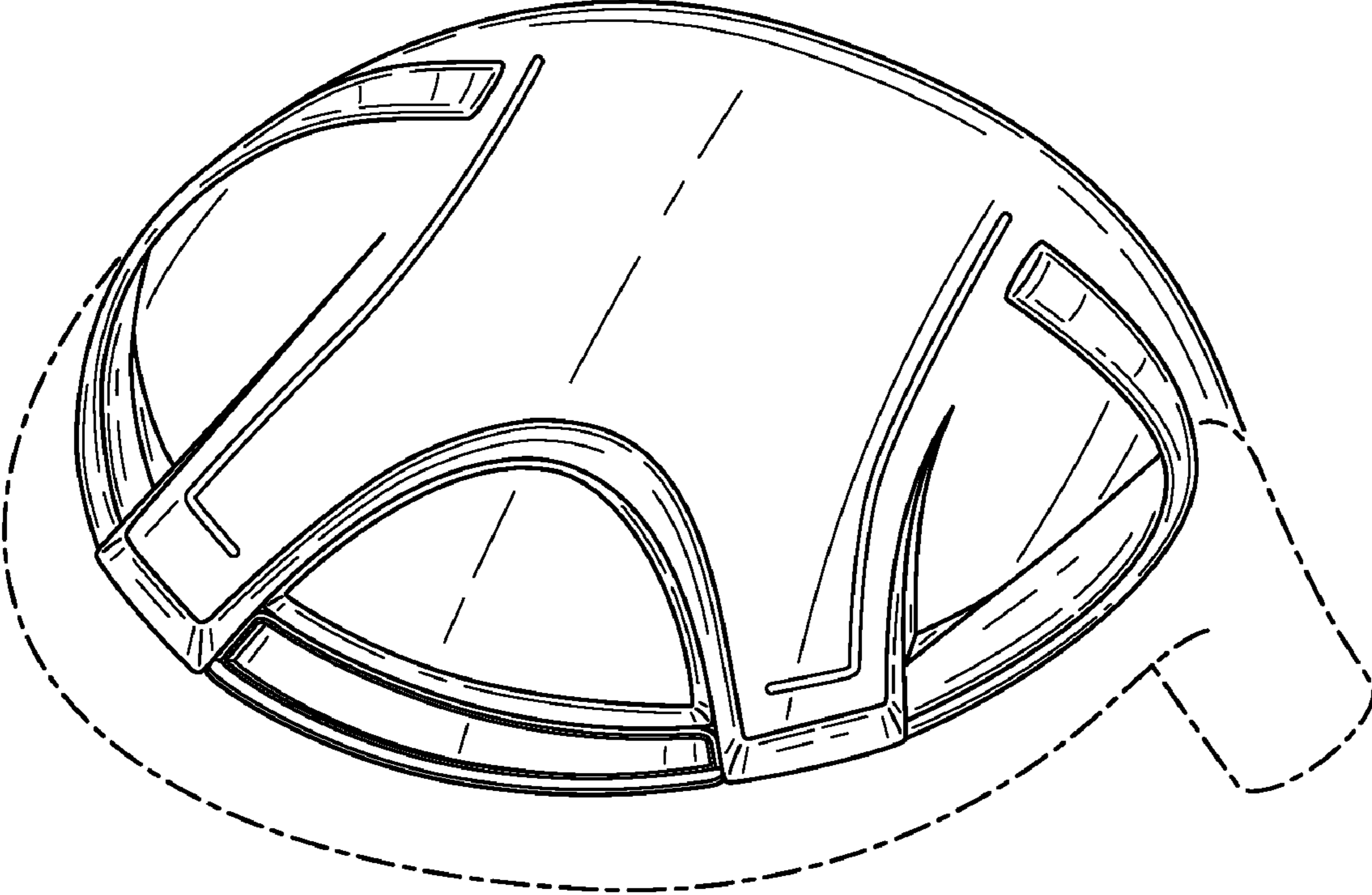

FIG. 1

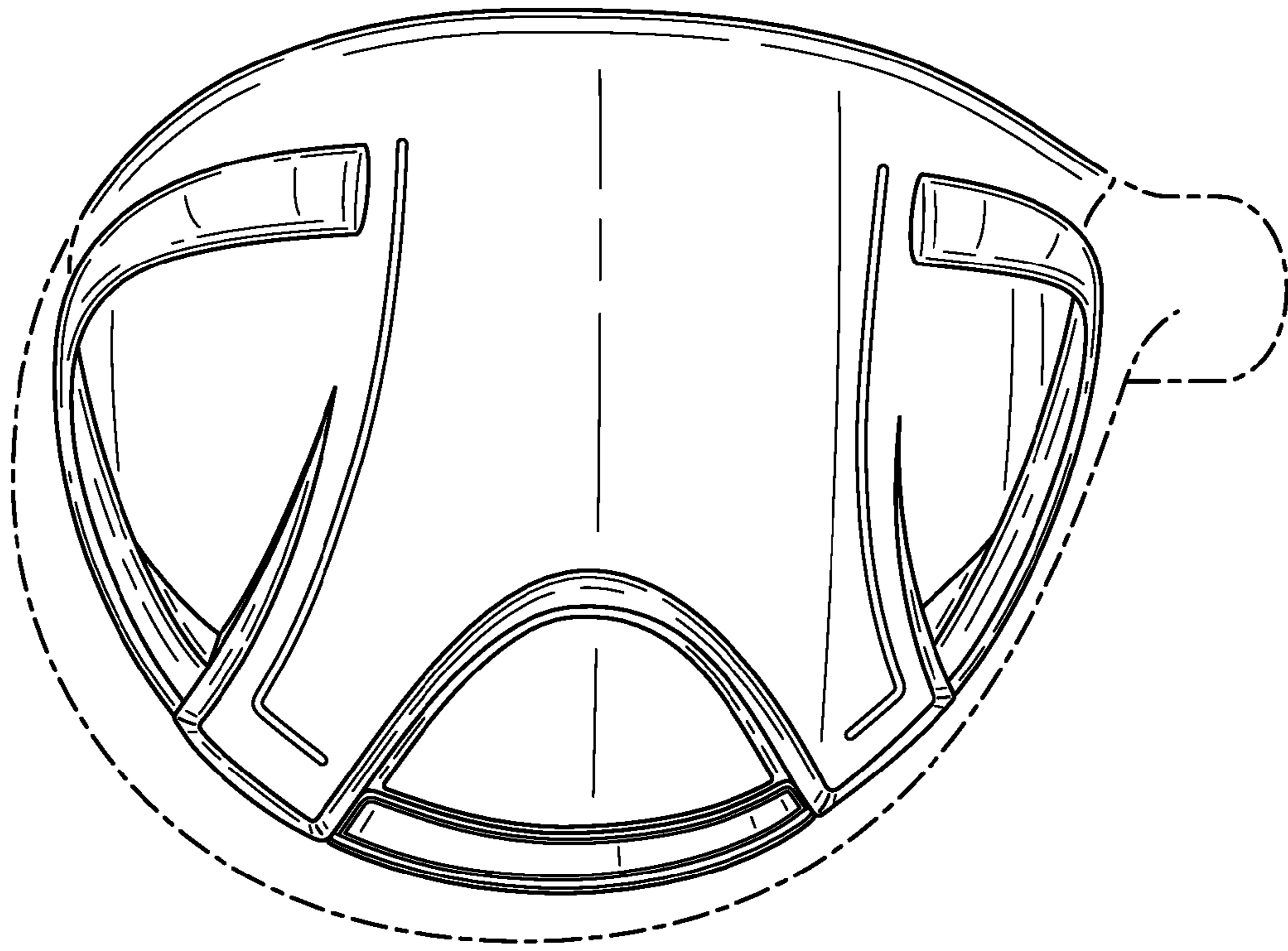

FIG. 2

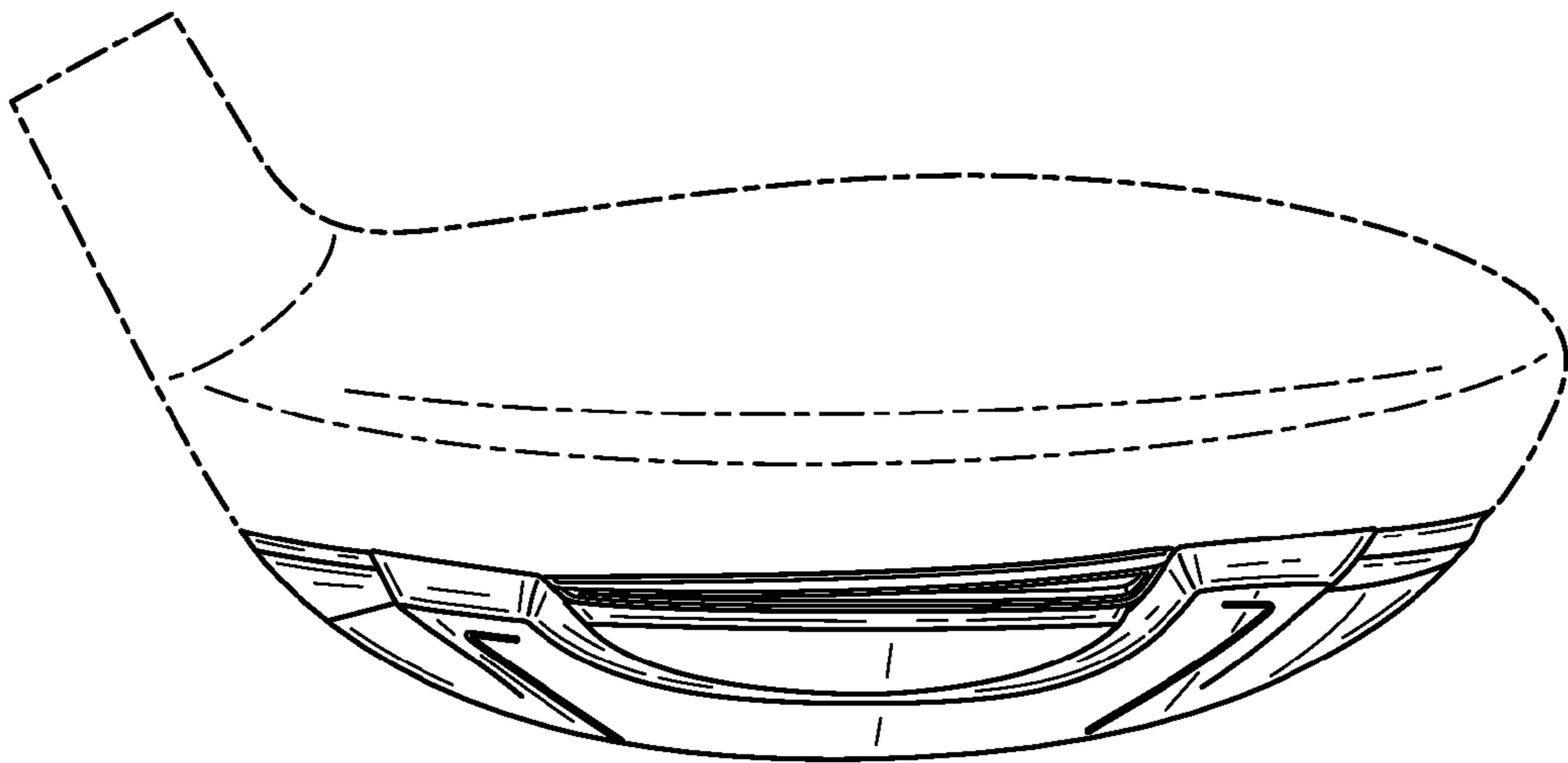

FIG. 3

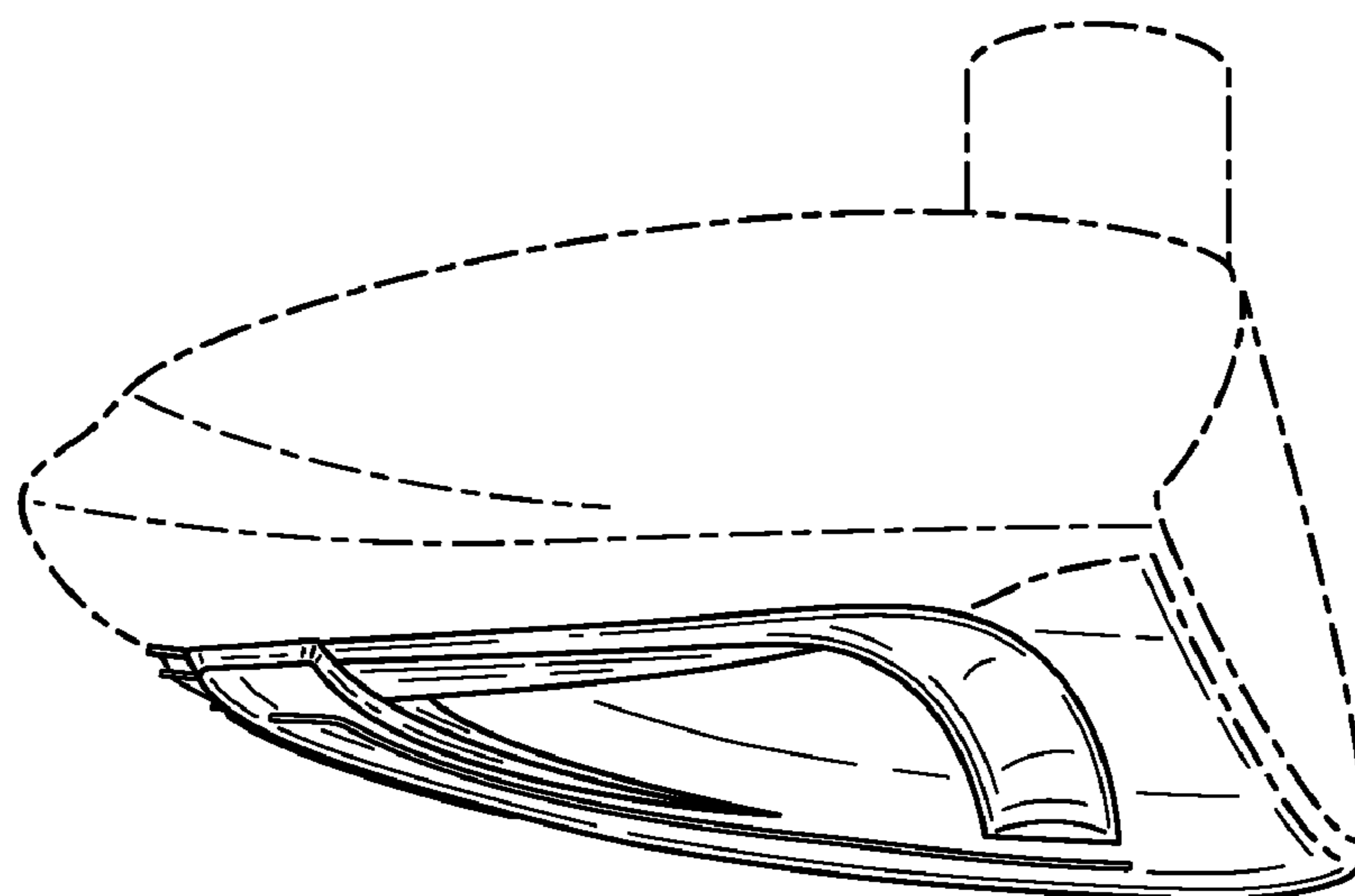

FIG. 4

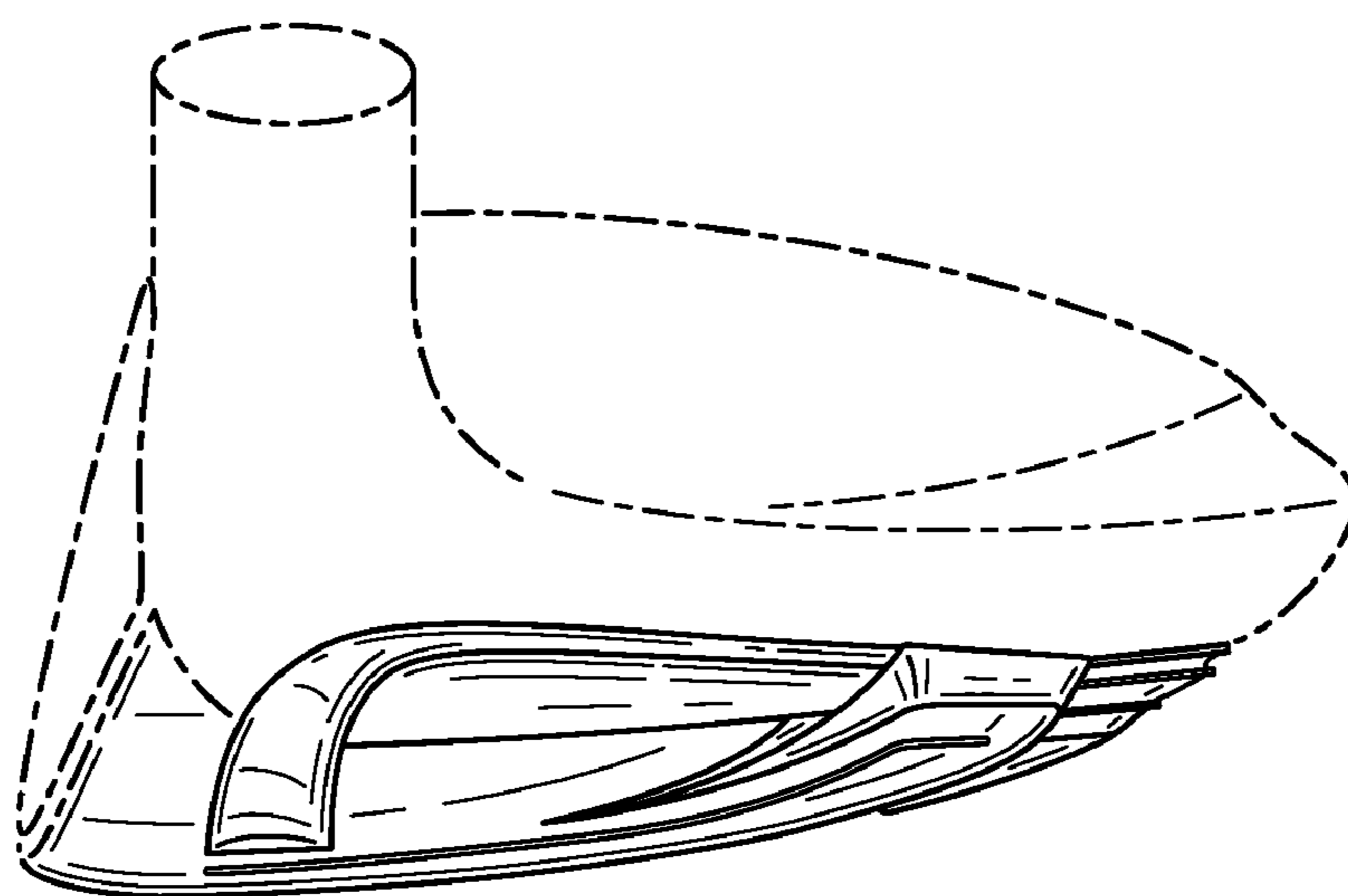

FIG. 5

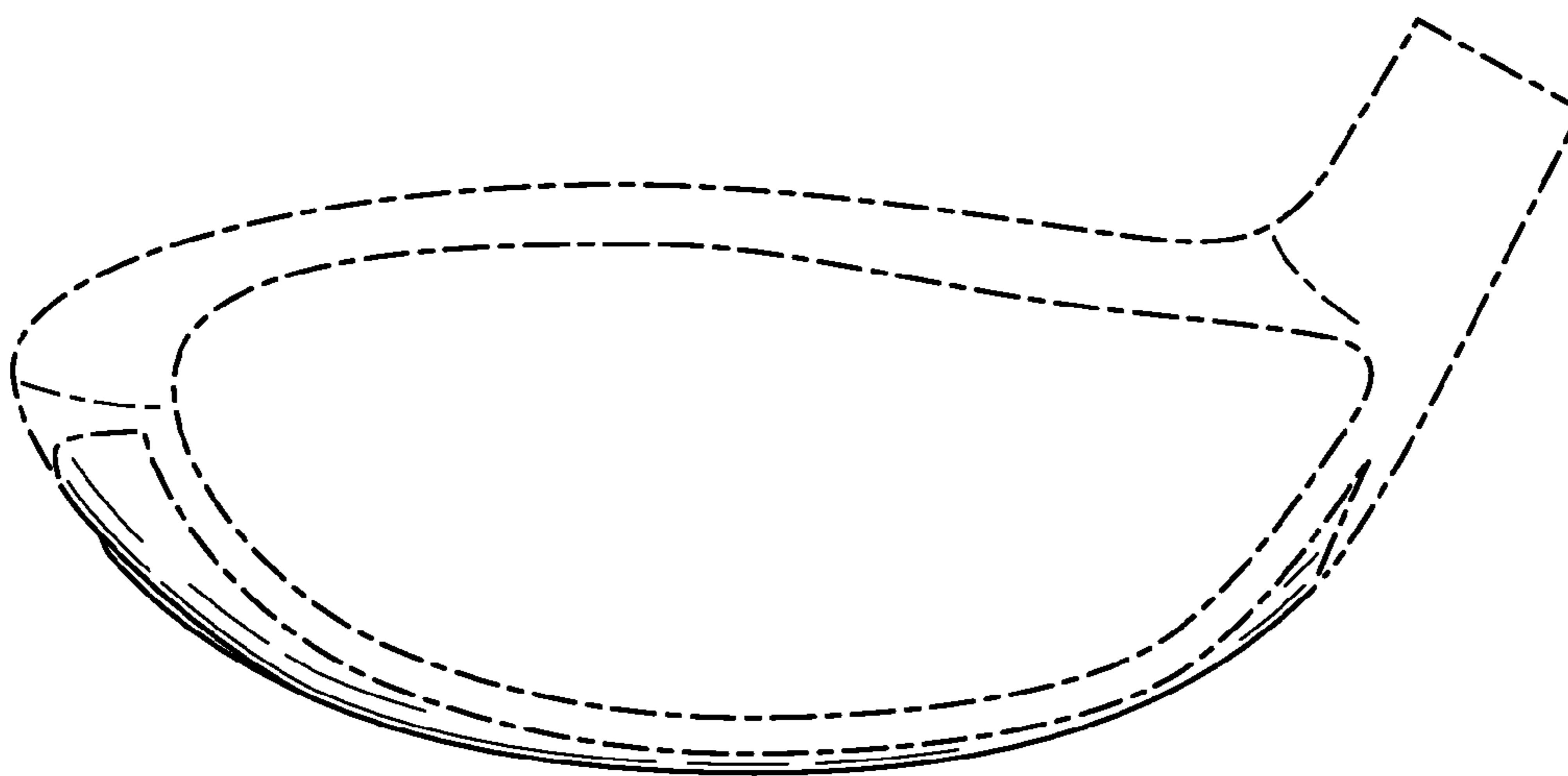

FIG. 6

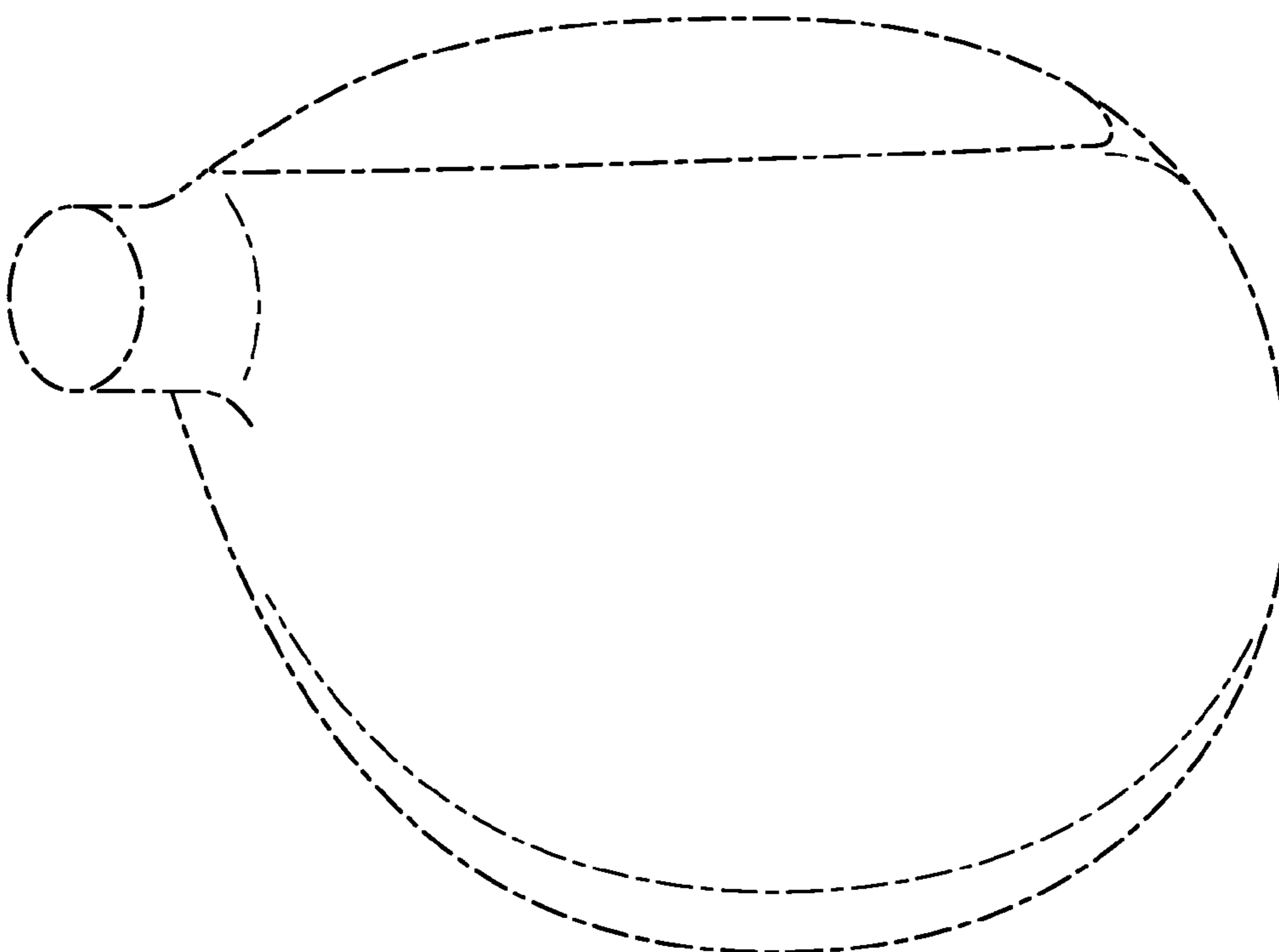

FIG. 7