

US00D609278S

(12) **United States Design Patent**  
**Schafer et al.**

(10) **Patent No.:** **US D609,278 S**  
(45) **Date of Patent:** **\*\* Feb. 2, 2010**

(54) **PIT STOP GAME**

(75) Inventors: **Sarah Schafer**, Arvada, CO (US);  
**Kellee C. Hasler**, Denver, CO (US)

(73) Assignee: **Events Unlimited, Inc.**, Denver, CO  
(US)

(\*\*) Term: **14 Years**

(21) Appl. No.: **29/323,737**

(22) Filed: **Aug. 29, 2008**

(51) **LOC (9) Cl.** ..... **21-01**

(52) **U.S. Cl.** ..... **D21/303; D21/320**

(58) **Field of Classification Search** ..... D21/320,  
D21/312, 300, 303; D12/604, 400; 463/1,  
463/6, 7, 46, 47; 273/390–393, 407, 318;  
434/219

See application file for complete search history.

(56) **References Cited**

**U.S. PATENT DOCUMENTS**

3,867,975	A *	2/1975	Johnson	.....	157/1.2
4,907,374	A *	3/1990	Brill	.....	451/342
4,987,703	A *	1/1991	Brill	.....	451/28
5,105,859	A *	4/1992	Bennett et al.	.....	141/102
5,542,574	A *	8/1996	Stern	.....	222/137
5,923,406	A *	7/1999	Brasington et al.	.....	355/40
6,675,719	B1 *	1/2004	Feider et al.	.....	104/32.1
6,676,509	B1	1/2004	Bear		
D591,080	S *	4/2009	Greiner	.....	D6/436
2009/0035107	A1 *	2/2009	Duran et al.	.....	414/426

**OTHER PUBLICATIONS**

<http://www.pitstoptour.com>, retreated on net Apr. 29, 2009, 1 page.\*  
<http://www.pitstopour.com/tire-change-game.htm>, retreated on Apr. 28, 2009, 1 page.\*

<http://www.pitstopour.com/Cot-game.htm>, retreated on Apr. 28, 2009.\*

<http://www.pitstopour.com/web/pit-stop-game.htm>, retreated on Apr. 28, 2009.\*

“Take the ‘Pit Crew Challenge’ —New Interactive Exhibit”, National Corvette Museum Website, available at <http://web.archive.org/web/20071225153422/www.corvettemuseum.com/new/index.shtml>, as early as Feb. 9, 2008, printed on Feb. 25, 2009, pp. 1-2.

“The Tire Change Game”, Pitstoptour.com website, available at <http://www.pitstoptour.com/tire-change-game.htm>, as early as Feb. 16, 2006, printed on Feb. 25, 2009, p. 1.

“EA Nascar Racing”, Thunderdome Racing Entertainment website, available at <http://www.thunderdomeracing.com/racing.htm>, as early as Aug. 10, 2003, printed on Feb. 25, 2009, pp. 1-9.

\* cited by examiner

*Primary Examiner*—Prabhakar Deshmukh

(74) *Attorney, Agent, or Firm*—Sheridan Ross P.C.

(57) **CLAIM**

The ornamental design for a pit stop game, as shown and described.

**DESCRIPTION**

FIG. 1 is a front perspective view of a pit stop game showing our new design;

FIG. 2 is a front elevation view thereof;

FIG. 3 is a rear elevation view thereof;

FIG. 4 is a top plan view thereof;

FIG. 5 is a left elevation view thereof;

FIG. 6 is a right elevation view thereof; and,

FIG. 7 is a bottom plan view thereof.

The broken lines shown in the figures comprise unclaimed subject matter that form no part of the claimed design.

**1 Claim, 2 Drawing Sheets**

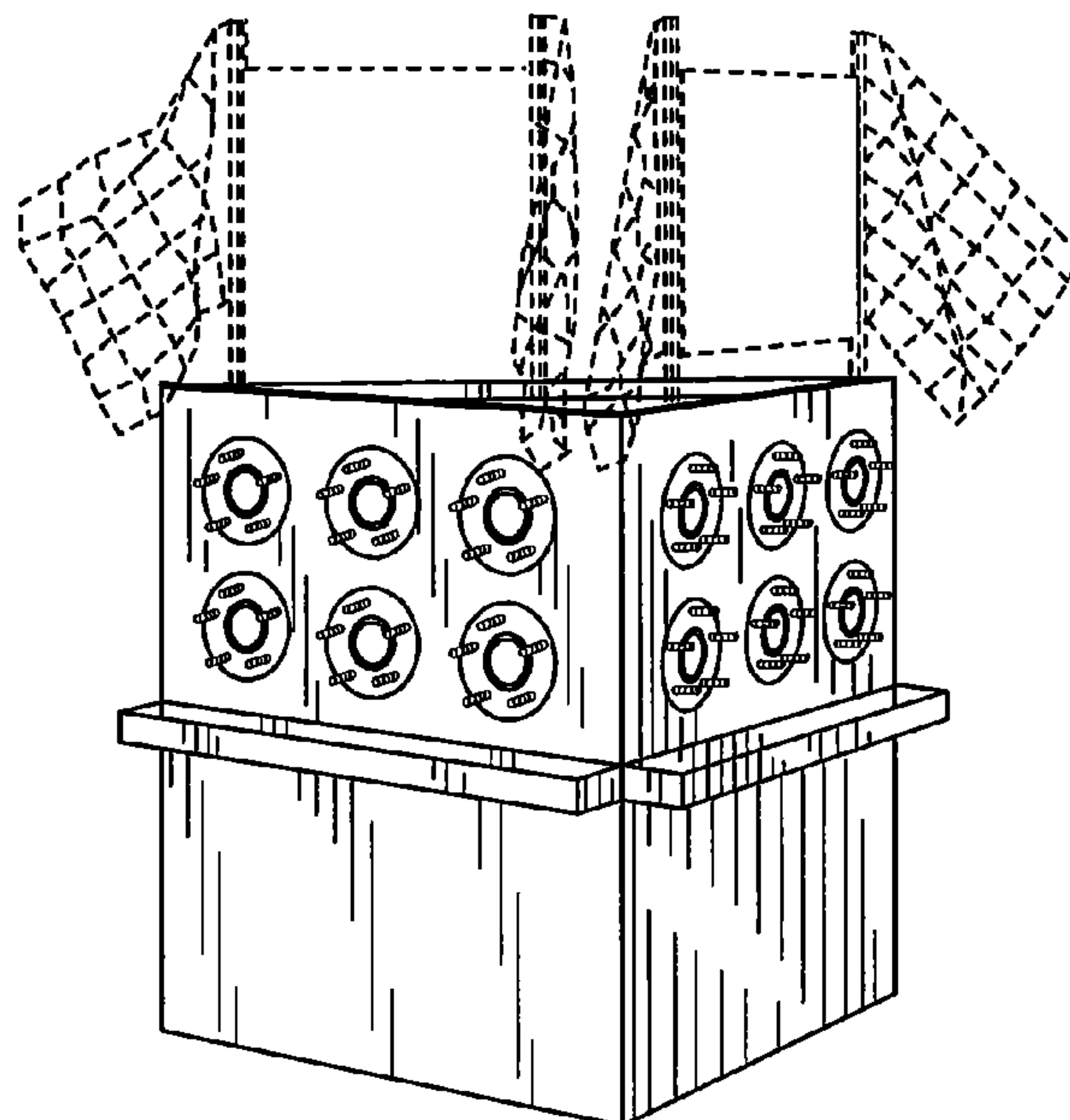

**Fig. 1**

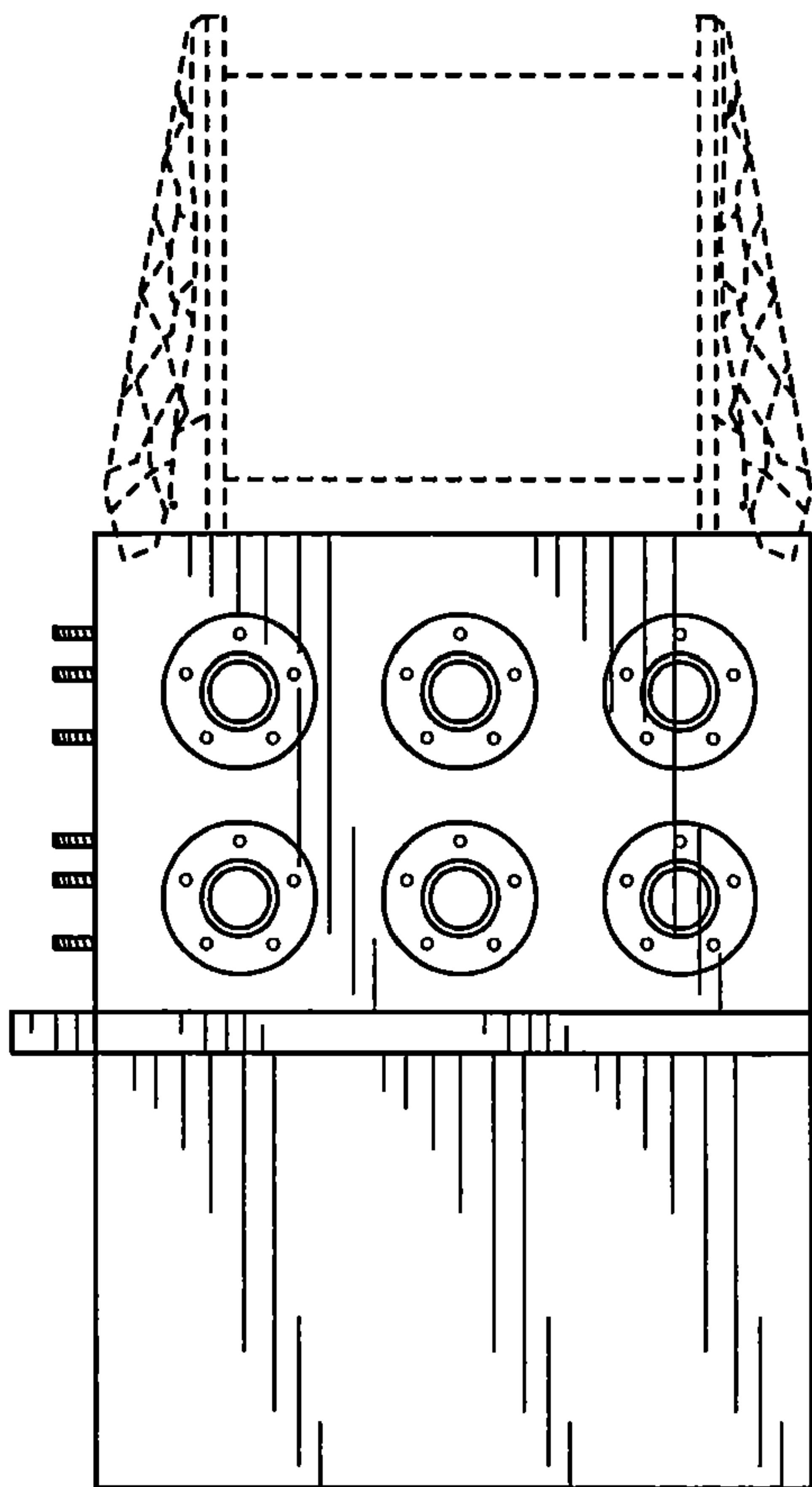
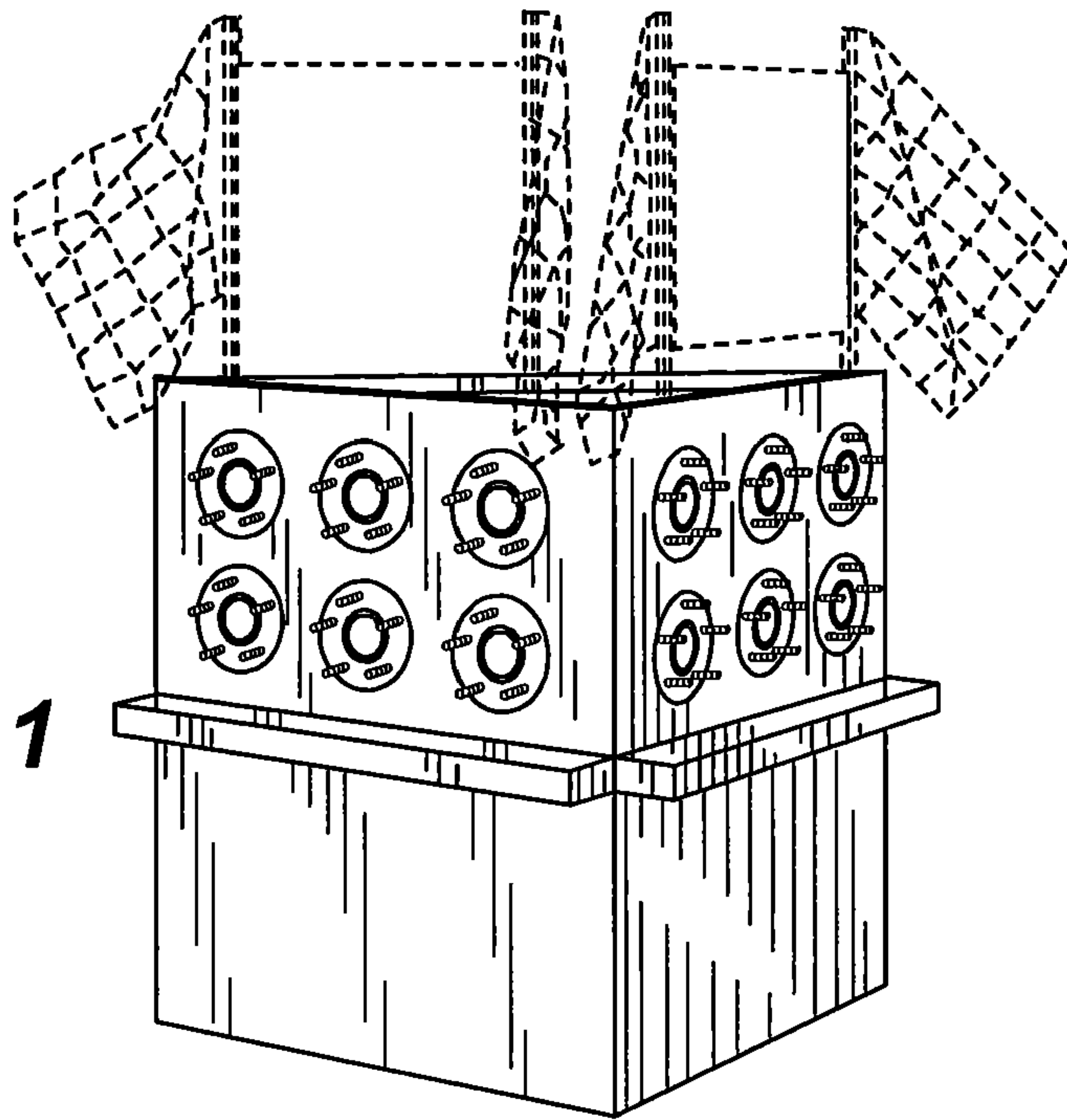

**Fig. 2**

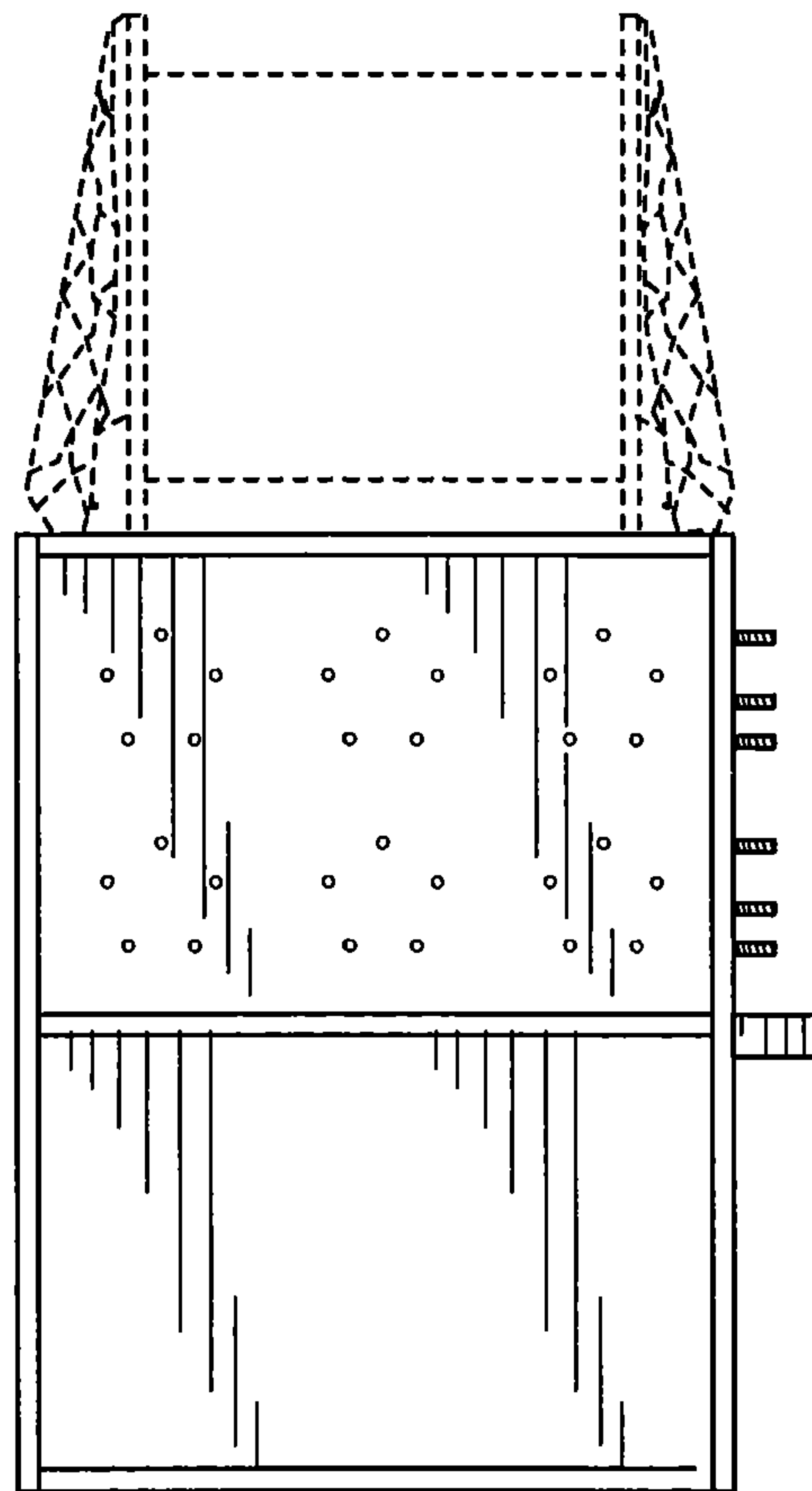

**Fig. 3**

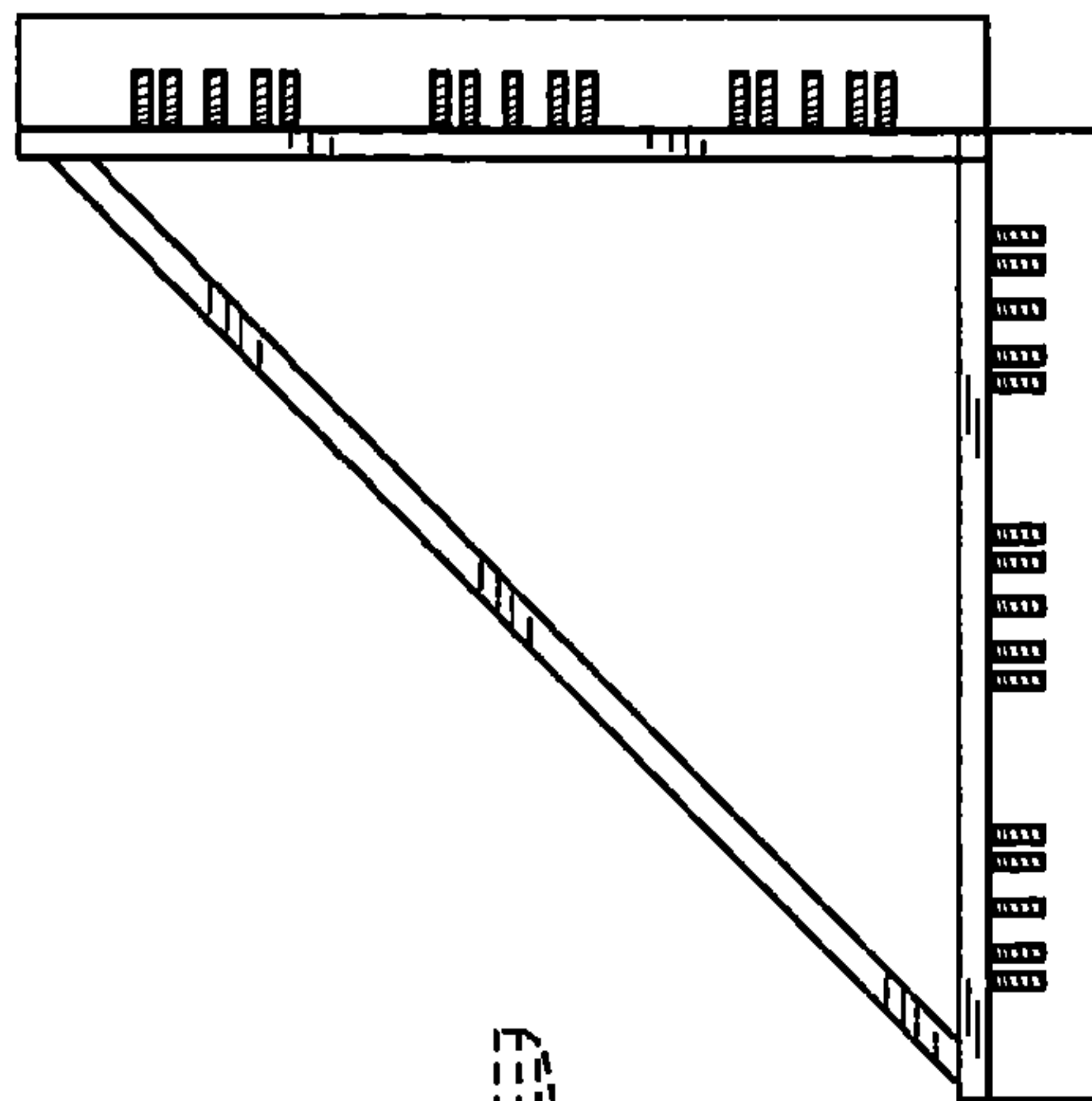

*Fig. 4*

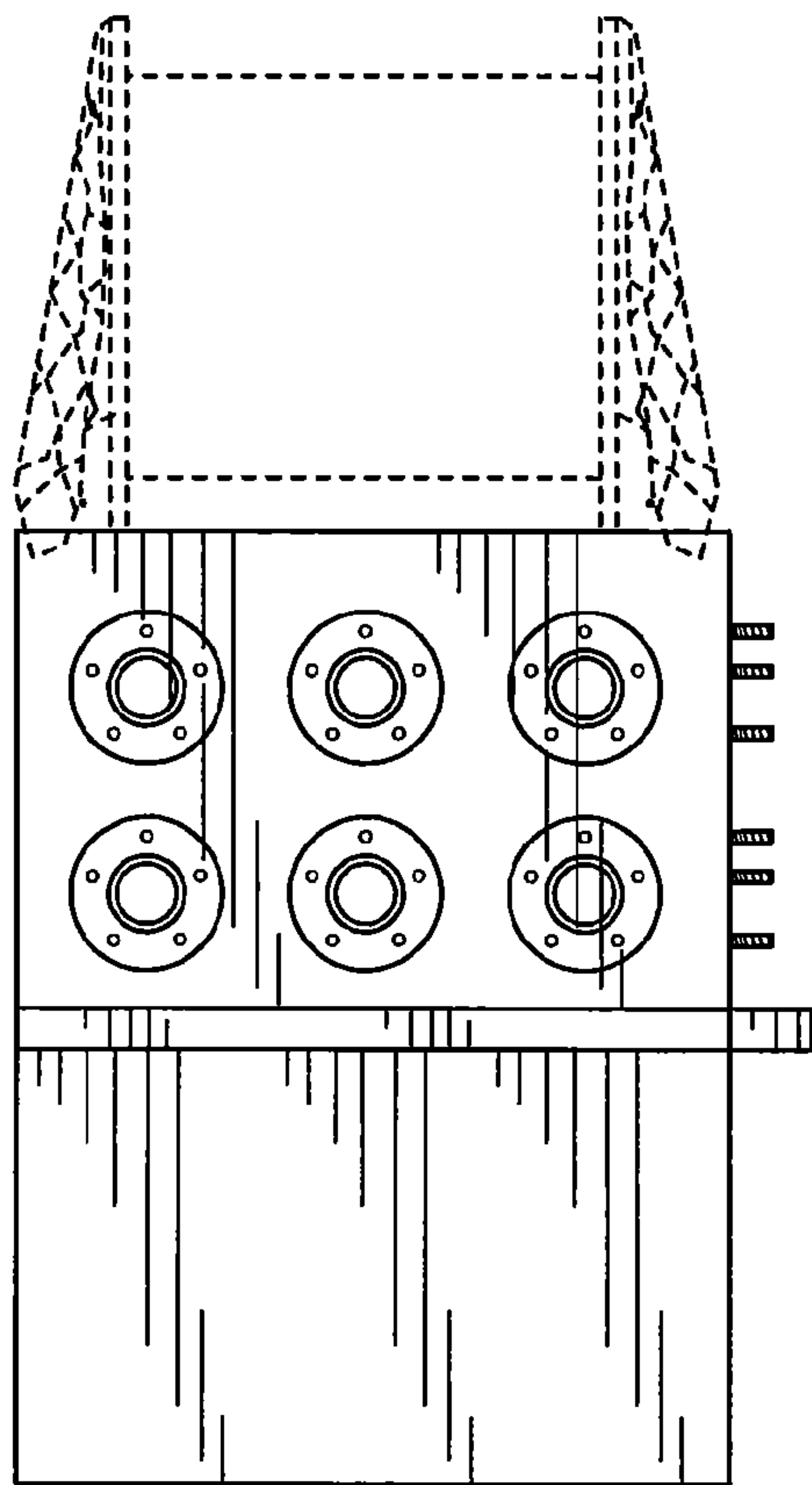

*Fig. 5*

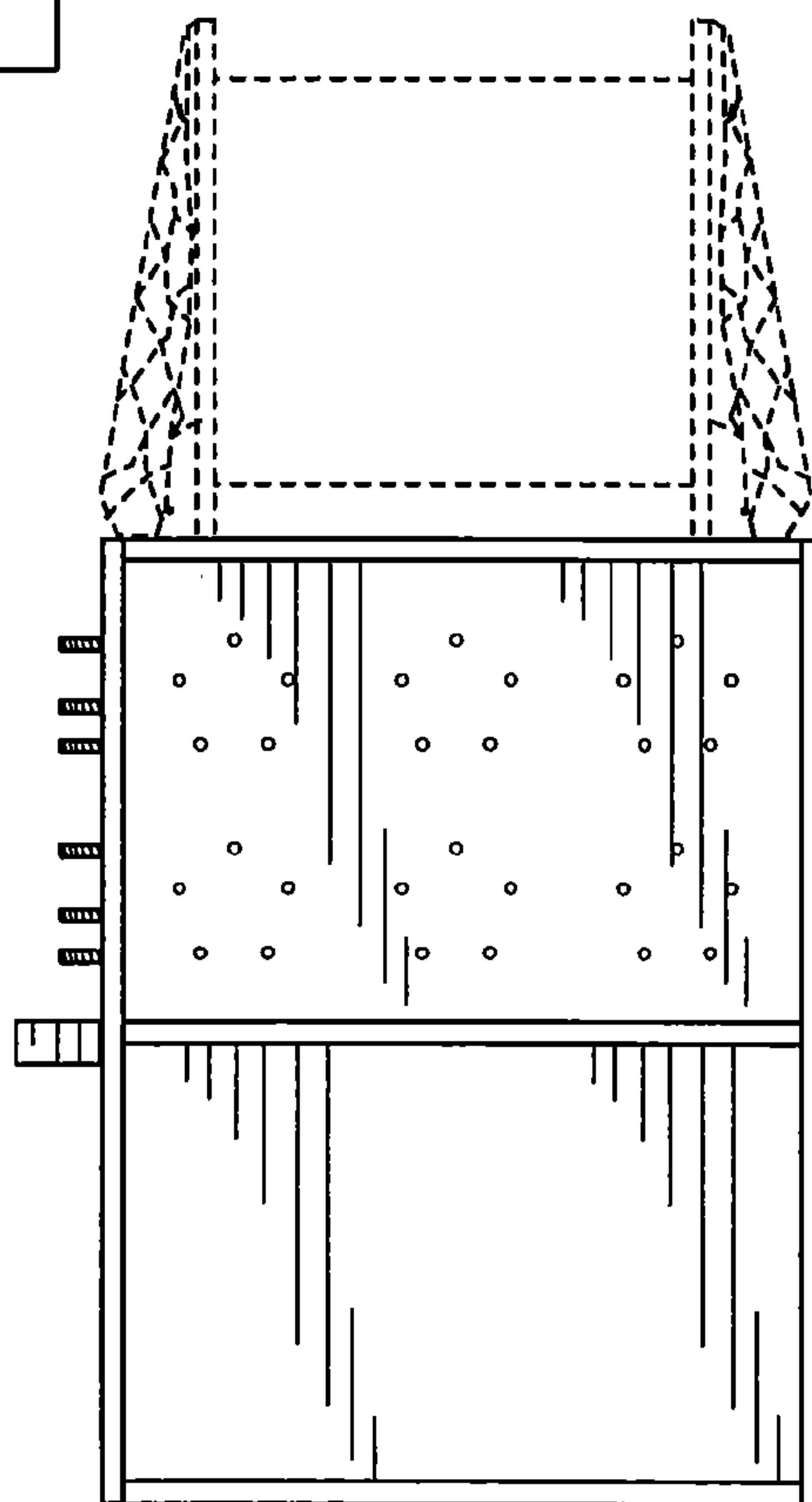

*Fig. 6*

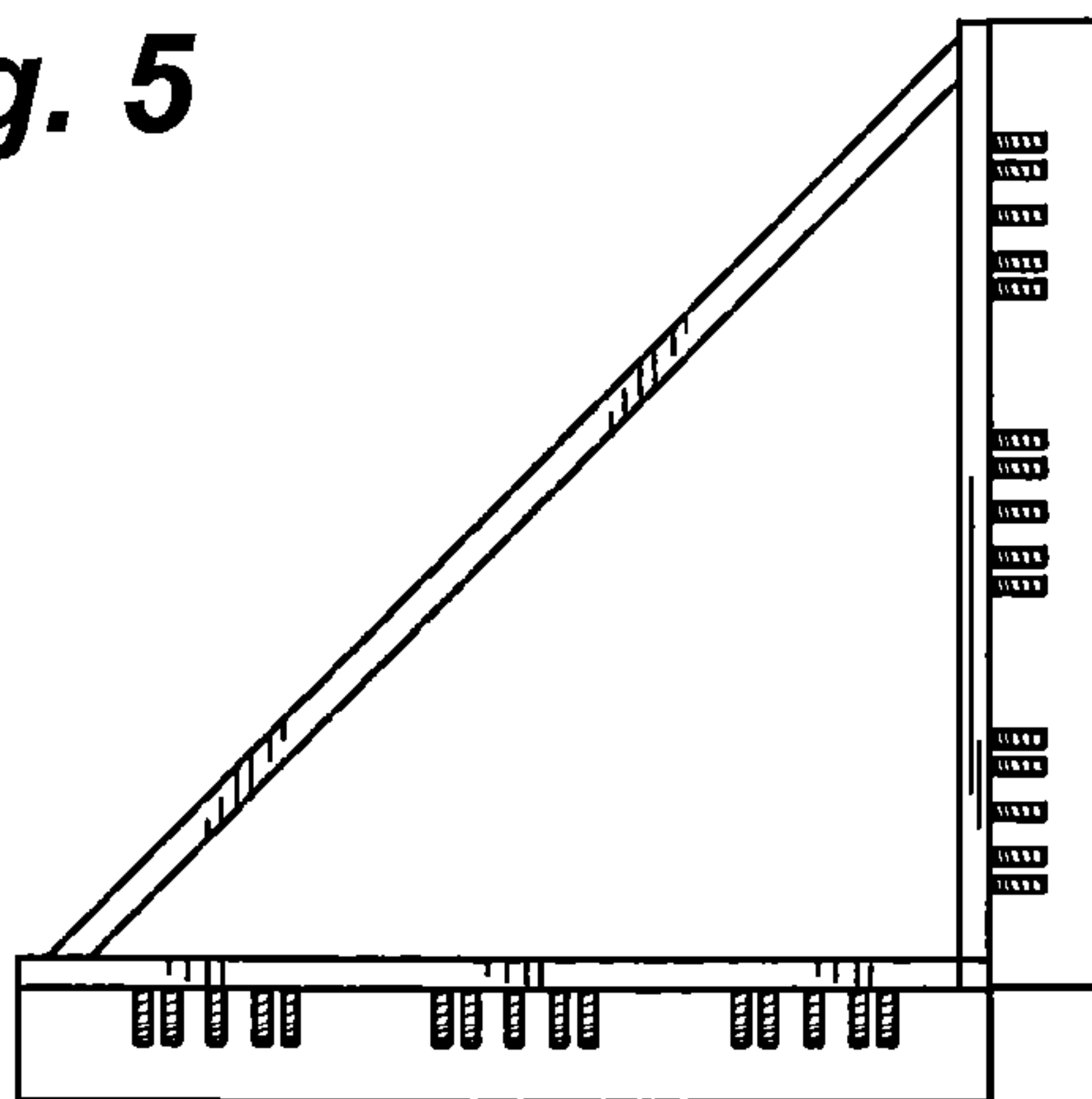

*Fig. 7*