



US00D609175S

(12) **United States Design Patent**
Feider et al.

(10) **Patent No.:** **US D609,175 S**

(45) **Date of Patent:** **** Feb. 2, 2010**

(54) **TIRE**

(75) Inventors: **Georges Gaston Feider**, Bettborn (LU);
Krzysztof Florian Jakubiak, Ettelbruck (LU);
Georges Valentin Adam, Bissen (LU)

(73) Assignee: **The Goodyear Tire & Rubber Company**, Akron, OH (US)

(**) Term: **14 Years**

(21) Appl. No.: **29/302,453**

(22) Filed: **Jan. 17, 2008**

(51) **LOC (9) Cl.** **12-15**

(52) **U.S. Cl.** **D12/600; D12/586**

(58) **Field of Classification Search** D12/568–603;
152/209.1, 209.8, 209.9, 209.12, 209.18,
152/209.25

See application file for complete search history.

(56) **References Cited**

U.S. PATENT DOCUMENTS

D315,129 S	3/1991	Graas et al.	D12/147
D384,620 S	10/1997	Gillard et al.	D12/147
D416,837 S	* 11/1999	Moore	D12/600
D432,960 S	10/2000	Feider et al.	D12/147
D448,707 S	10/2001	Maziarka et al.	D12/147
D455,709 S	4/2002	Dixon et al.	D12/588
D456,769 S	* 5/2002	Dixon et al.	D12/600
D457,855 S	5/2002	Bawin et al.	D12/582
D517,472 S	3/2006	Allison	D12/602
D517,978 S	3/2006	Robert	D12/600
D534,117 S	12/2006	Welbes et al.	D12/584
D534,484 S	1/2007	Feider et al.	D12/584

D554,053 S * 10/2007 Feider et al. D12/588

* cited by examiner

Primary Examiner—Robert M Spear

Assistant Examiner—George D Kirschbaum

(74) *Attorney, Agent, or Firm*—Richard B. O’Planick

(57) **CLAIM**

The ornamental design for a tire, as shown and described.

DESCRIPTION

FIG. 1 is a perspective view of a tire showing our new design, it being understood that the pattern repeats uniformly throughout the circumference of the tread;

FIG. 2 is a front elevational view thereof;

FIG. 3 is a right side elevational view thereof; the opposite side elevational view being identical thereto;

FIG. 4 is an enlarged fragmentary front elevational view thereof;

FIG. 5 is a perspective view of a second embodiment of a tire showing our new design, it being understood that the pattern repeats uniformly throughout the circumference of the tread and that the opposite side perspective view is identical thereto; and,

FIG. 6 is a front elevational view of a second embodiment, it being understood that an enlarged fragmentary view thereof would be substantially identical to that shown in FIG. 4, with the exception of the inclusion of the sidewall in solid lines.

In FIGS. 1–4, the broken lines defining the sidewall, inner bead and the peripheral boundary between the claimed tire tread and the sidewall depict environmental subject matter that forms no part of the claimed design.

1 Claim, 6 Drawing Sheets

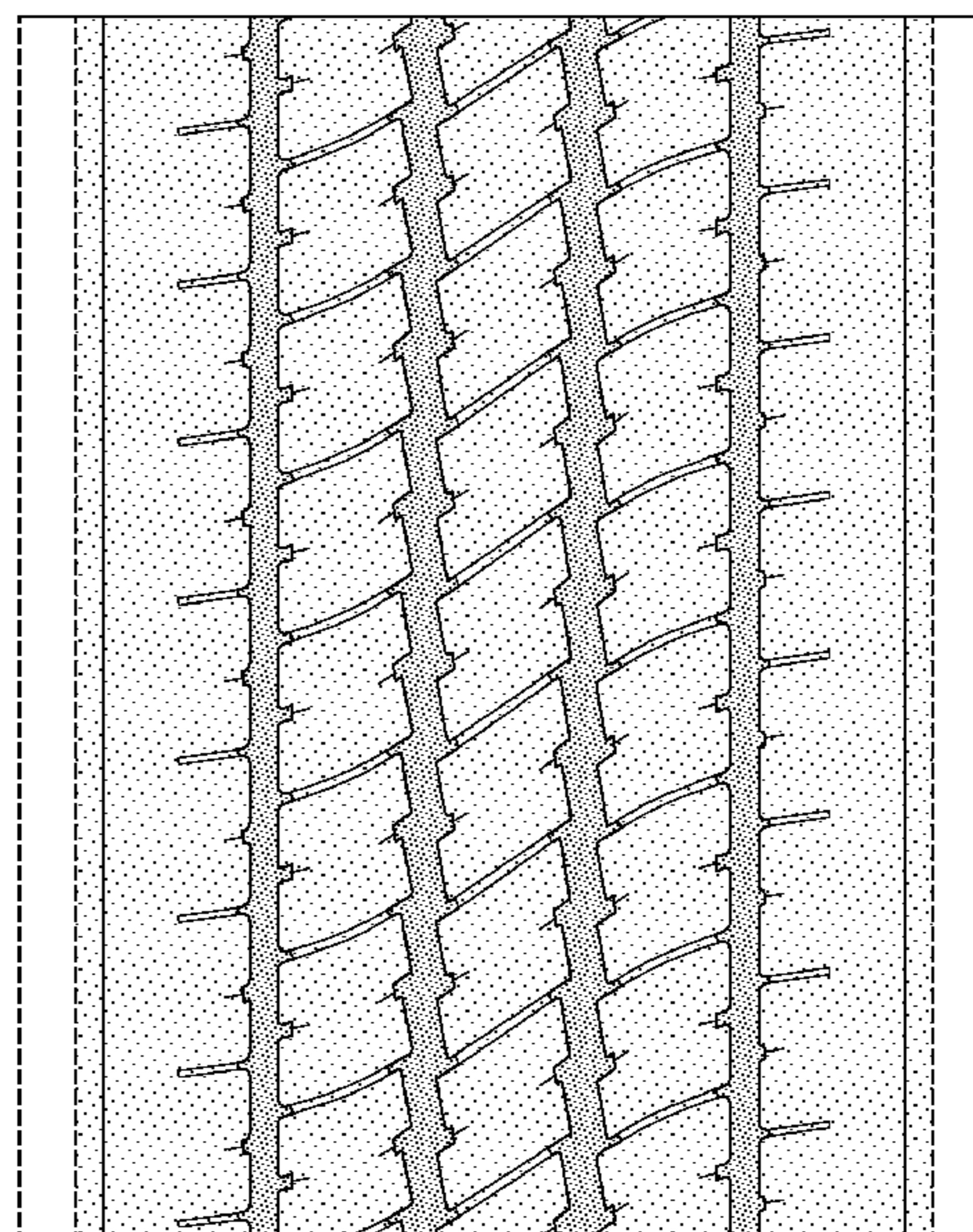
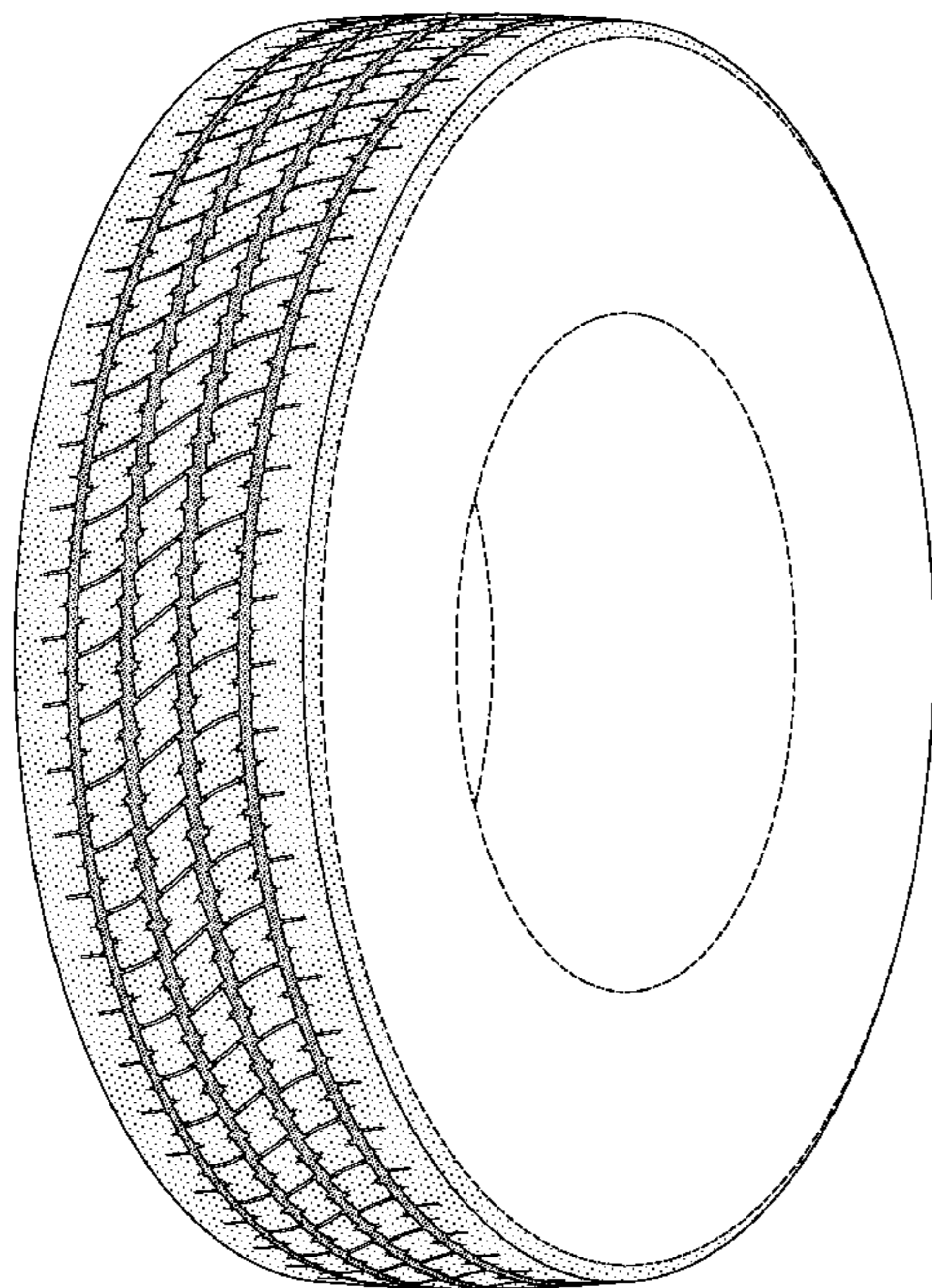

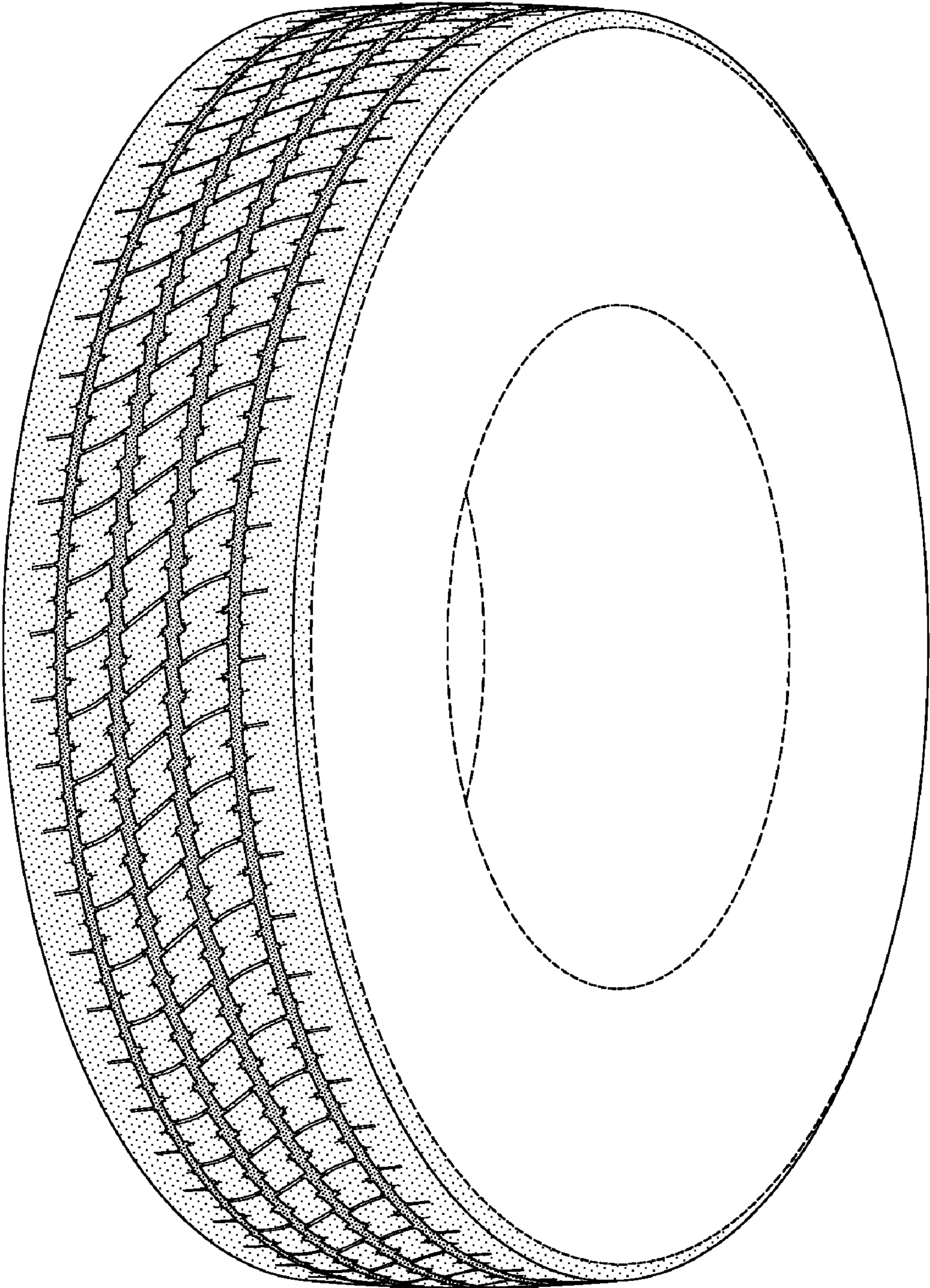

FIG-1

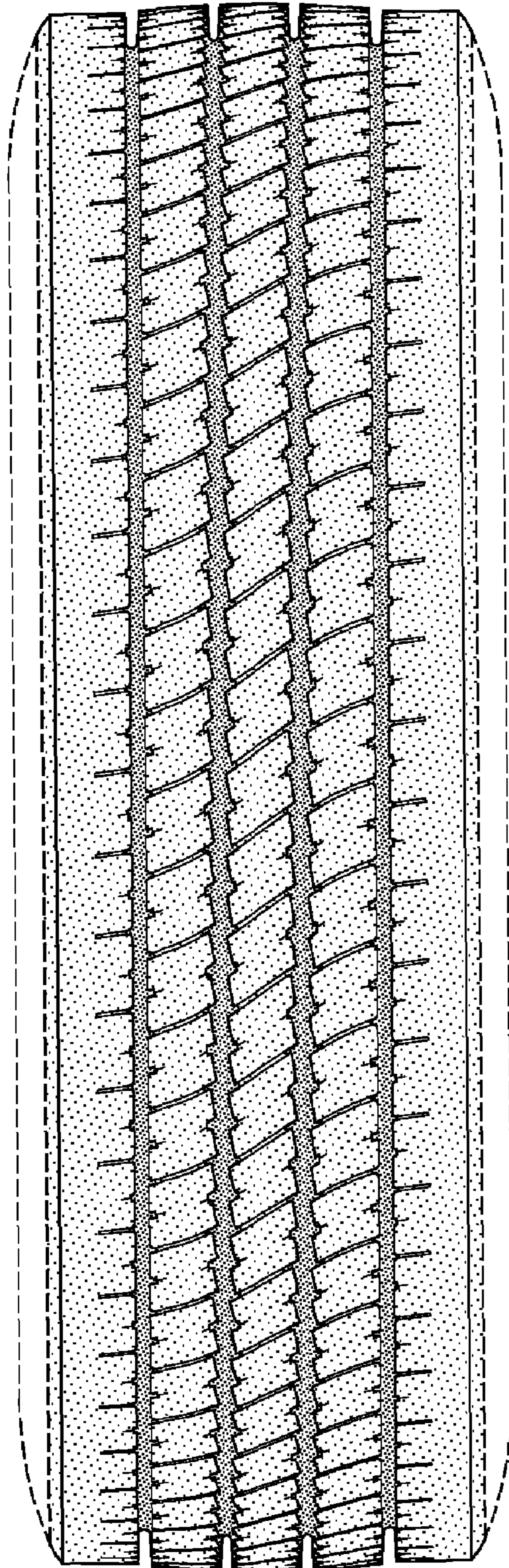

FIG-2

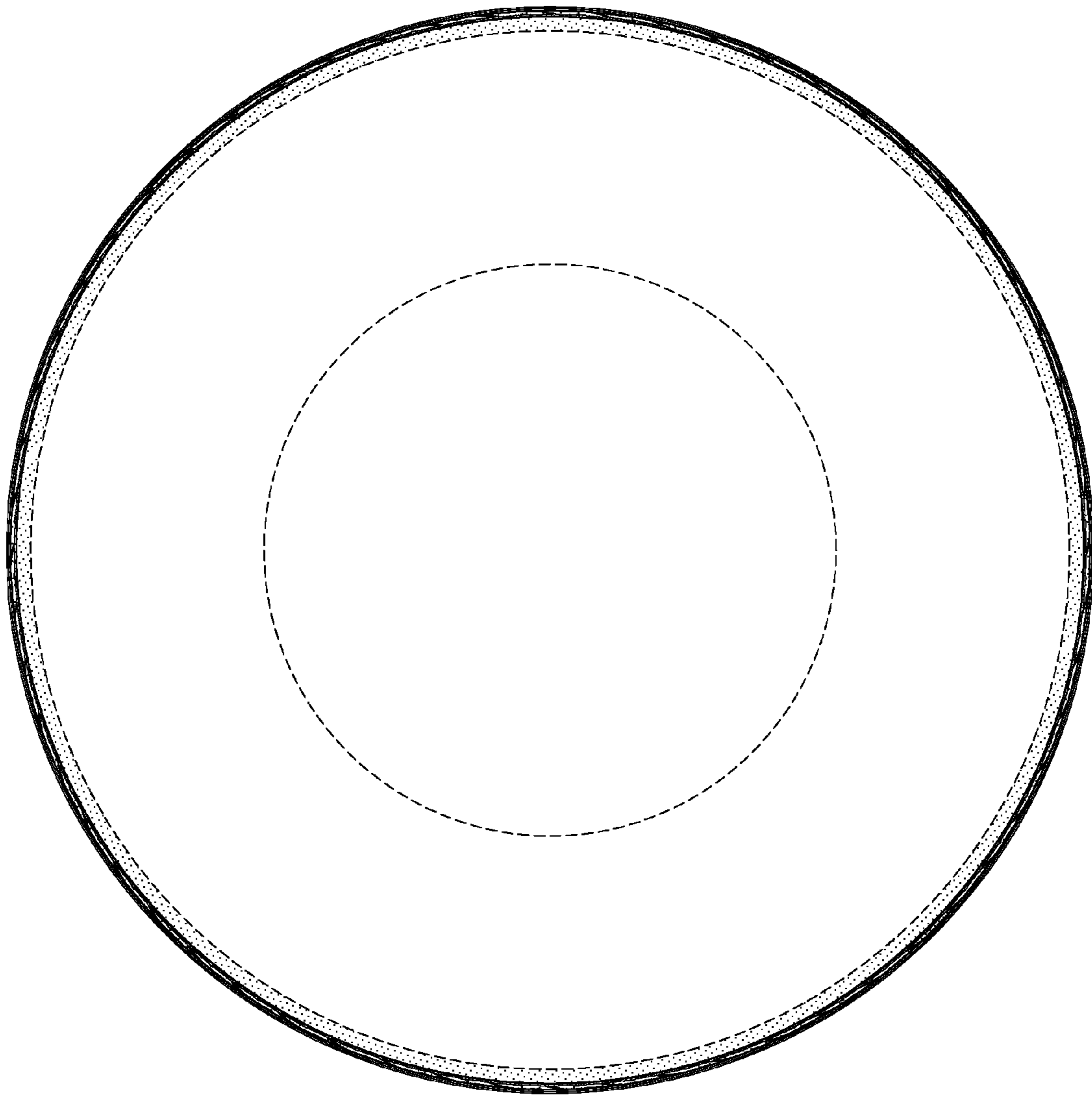

FIG-3

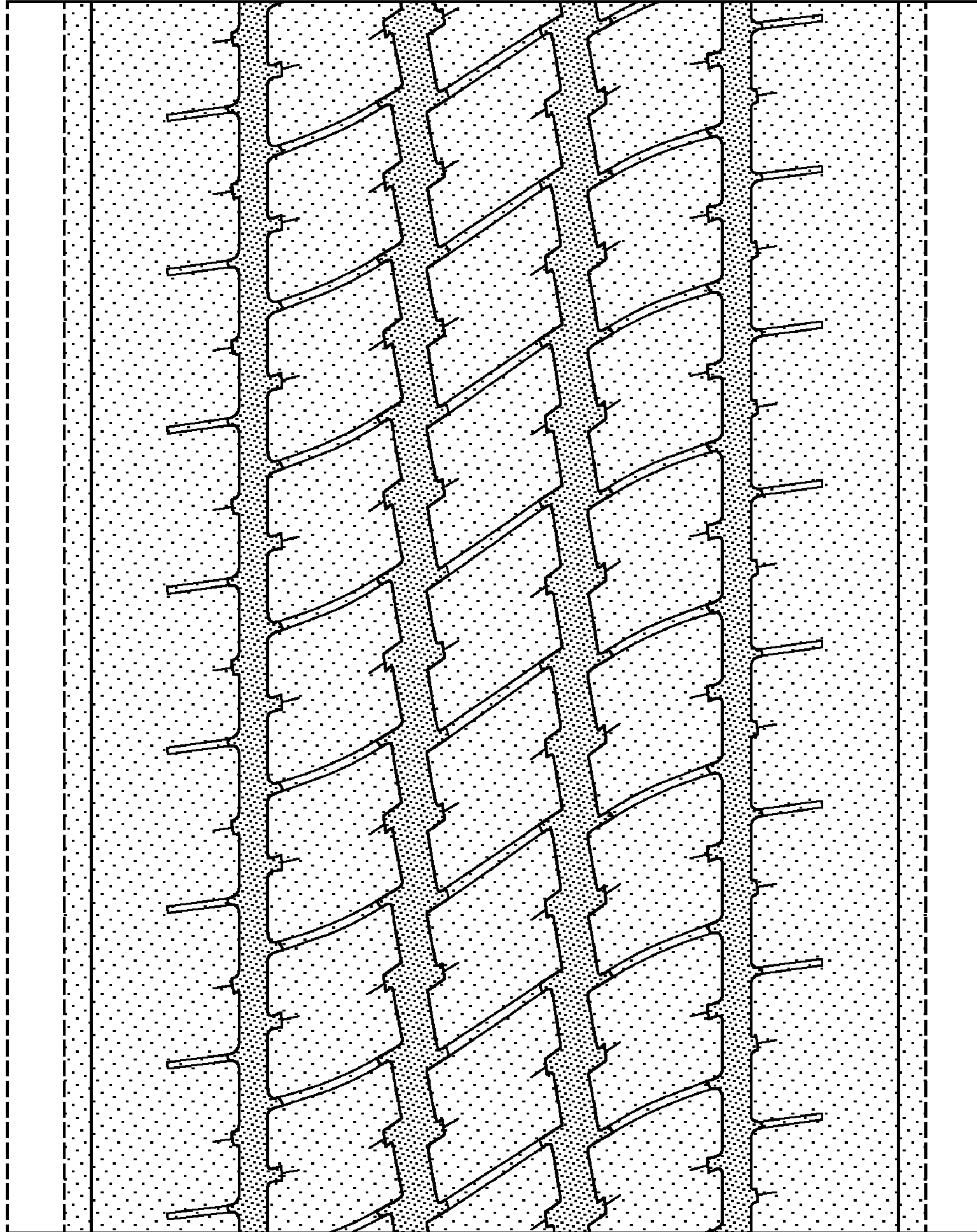

FIG-4

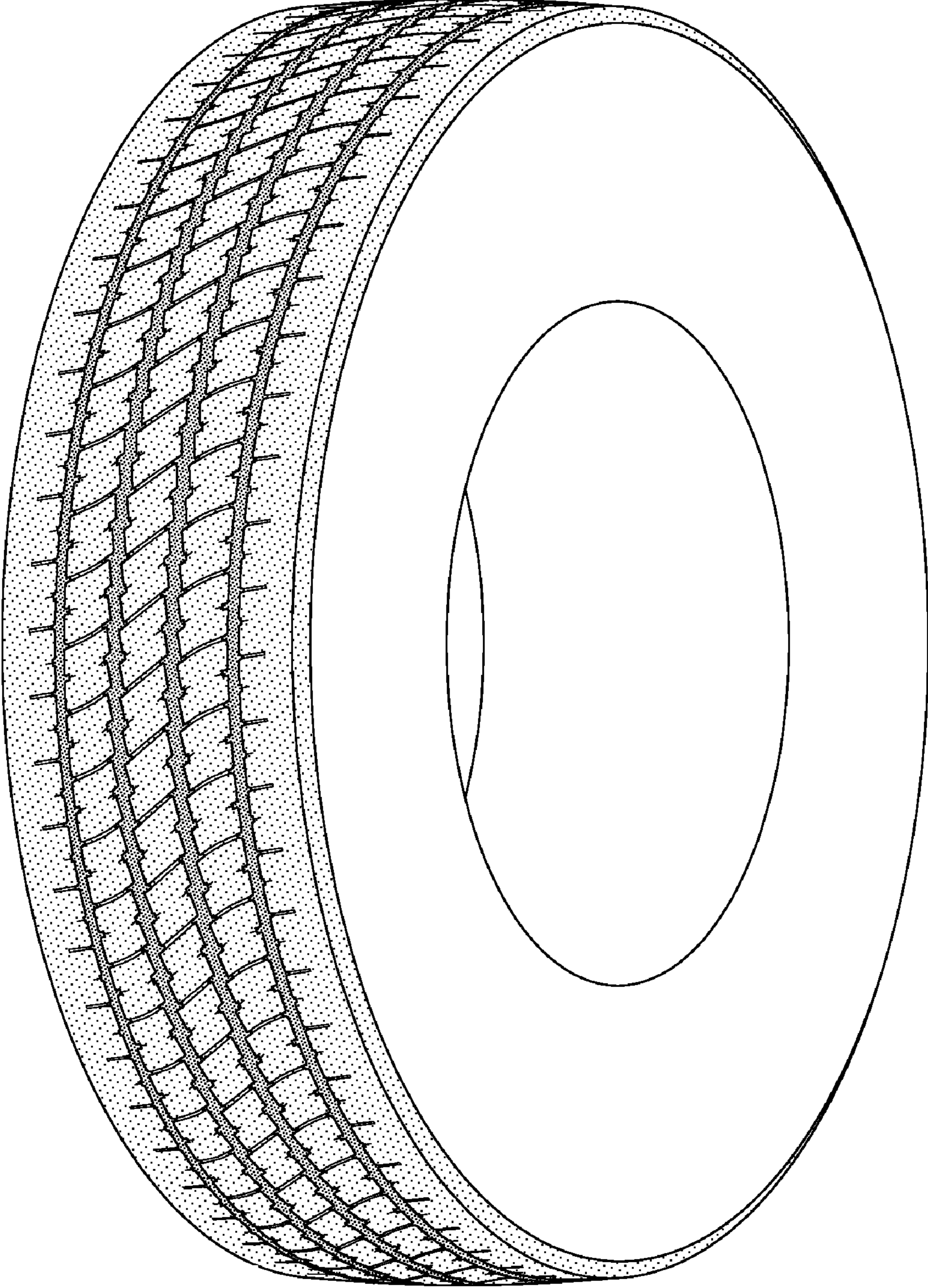

FIG-5

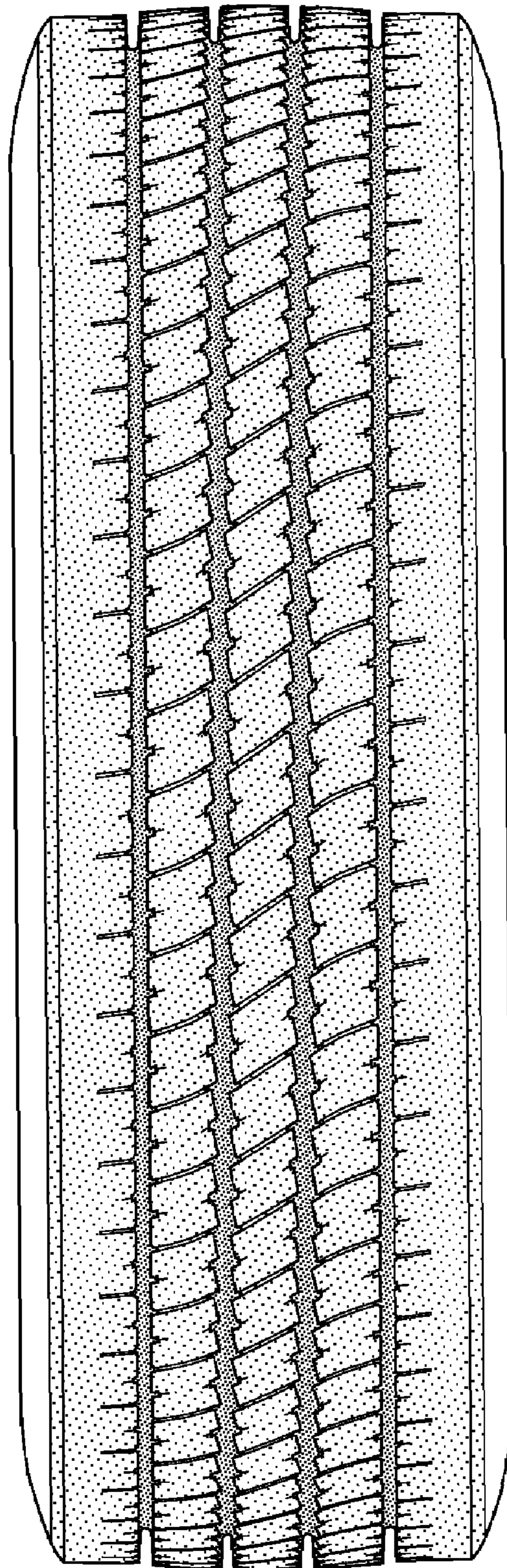

FIG-6