



US00D609105S

(12) **United States Design Patent**
Tiefenback

(10) **Patent No.:** **US D609,105 S**

(45) **Date of Patent:** **** Feb. 2, 2010**

(54) **BOTTLE**

D572,143 S * 7/2008 Laupie D9/538
D582,780 S * 12/2008 Bourne D9/538
D584,628 S * 1/2009 Lepoitevin D9/538

(75) Inventor: **Jason Tiefenback**, Philadelphia, PA
(US)

* cited by examiner

(73) Assignee: **Campbell Soup Company**, Camden, NJ
(US)

Primary Examiner—Stella M Reid

Assistant Examiner—Keli L Hill

(**) Term: **14 Years**

(74) *Attorney, Agent, or Firm*—Goodwin Procter LLP

(21) Appl. No.: **29/310,150**

(57) **CLAIM**

(22) Filed: **Jul. 28, 2008**

The ornamental design for a bottle, as shown and described.

(51) **LOC (9) Cl.** **09-01**

DESCRIPTION

(52) **U.S. Cl.** **D9/539; D9/538; D9/552;**
D9/574

FIG. 1 is a front, top perspective view of a bottle, showing my new design;

(58) **Field of Classification Search** D9/516,
D9/520, 530, 537–539, 542, 552, 553, 556,
D9/558, 562, 565, 566, 569, 571, 574; 215/382–384;
220/662, 669, 675

FIG. 2 is a right side elevation view thereof, the left side elevation view being identical thereto;

See application file for complete search history.

FIG. 3 is a front elevation view thereof, the rear elevation view being identical thereto;

(56) **References Cited**

FIG. 4 is top plan view thereof; and,

U.S. PATENT DOCUMENTS

FIG. 5 is a bottom plan view thereof.

D423,940 S * 5/2000 Chimetto D9/541
D510,027 S * 9/2005 Zboch et al. D9/552
D556,591 S * 12/2007 Kort et al. D9/552
D560,502 S * 1/2008 Darr et al. D9/552
D561,042 S * 2/2008 Darr et al. D9/550
D572,135 S * 7/2008 Lepoitevin D9/538

The dash lines shown in the drawings are for illustrative purposes only and form no part of the claimed design.

The dot-dash-dot lines shown in the drawings define the boundary of the claim and form no part of the claimed design.

1 Claim, 4 Drawing Sheets

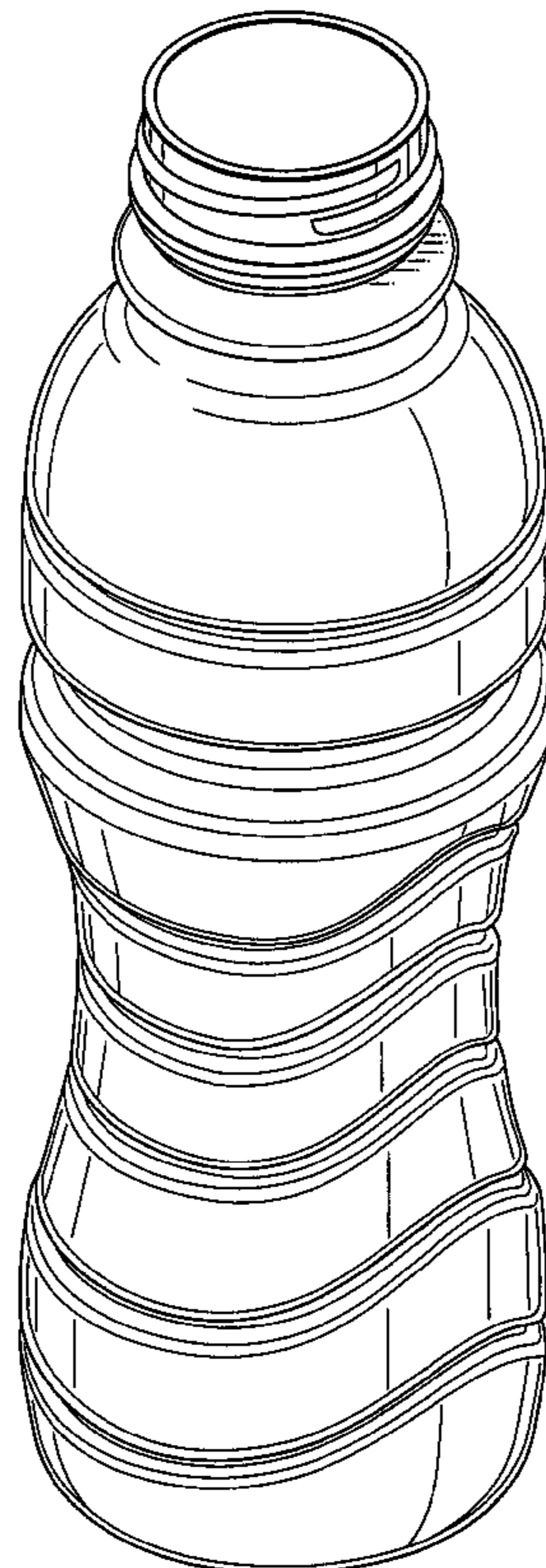

Fig. 1

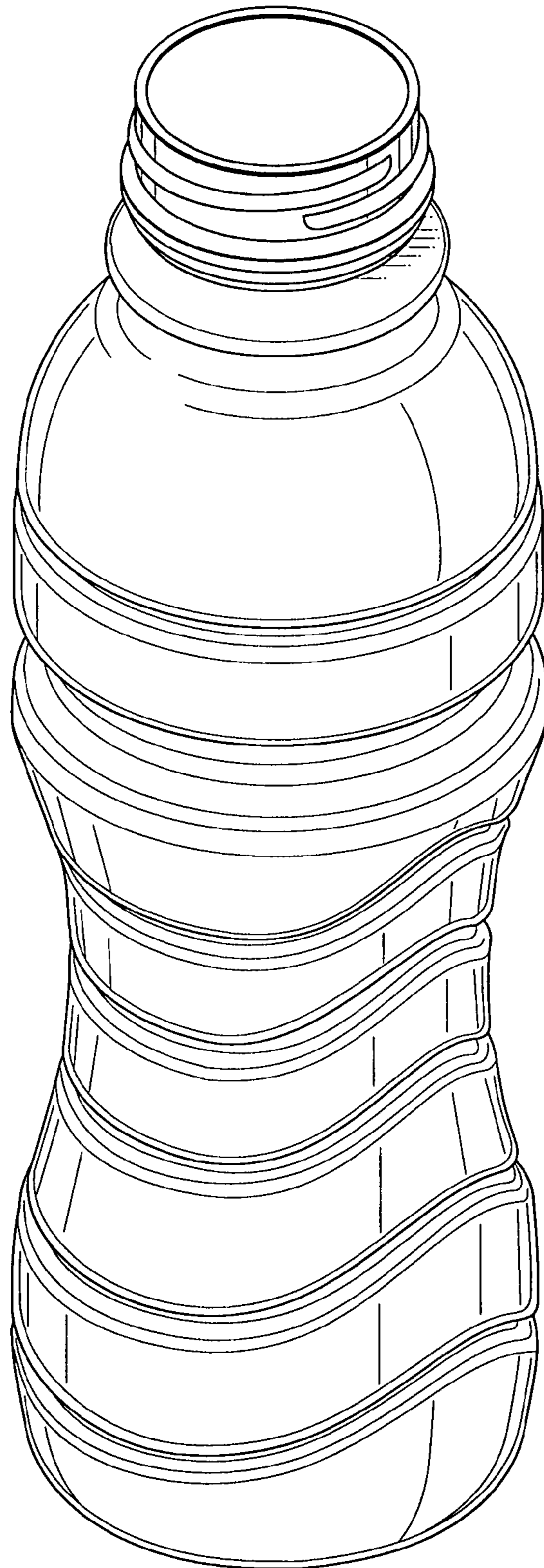

Fig. 2

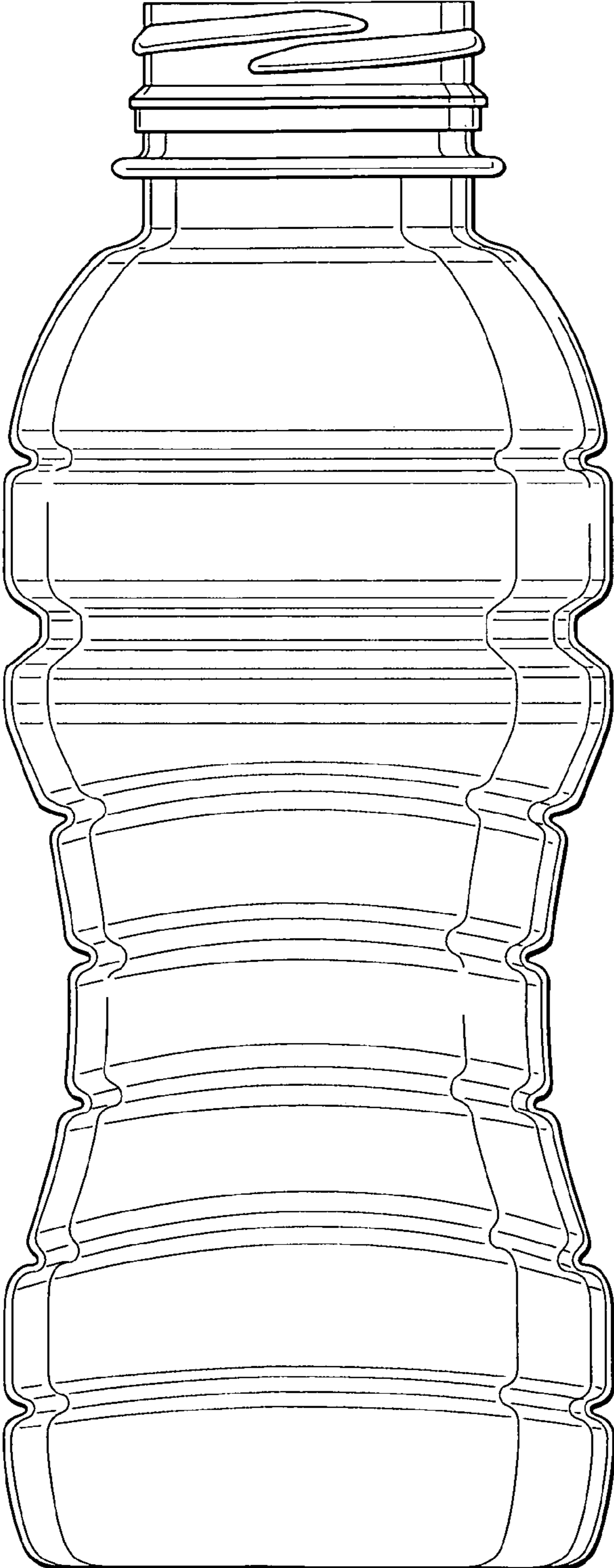

Fig. 3

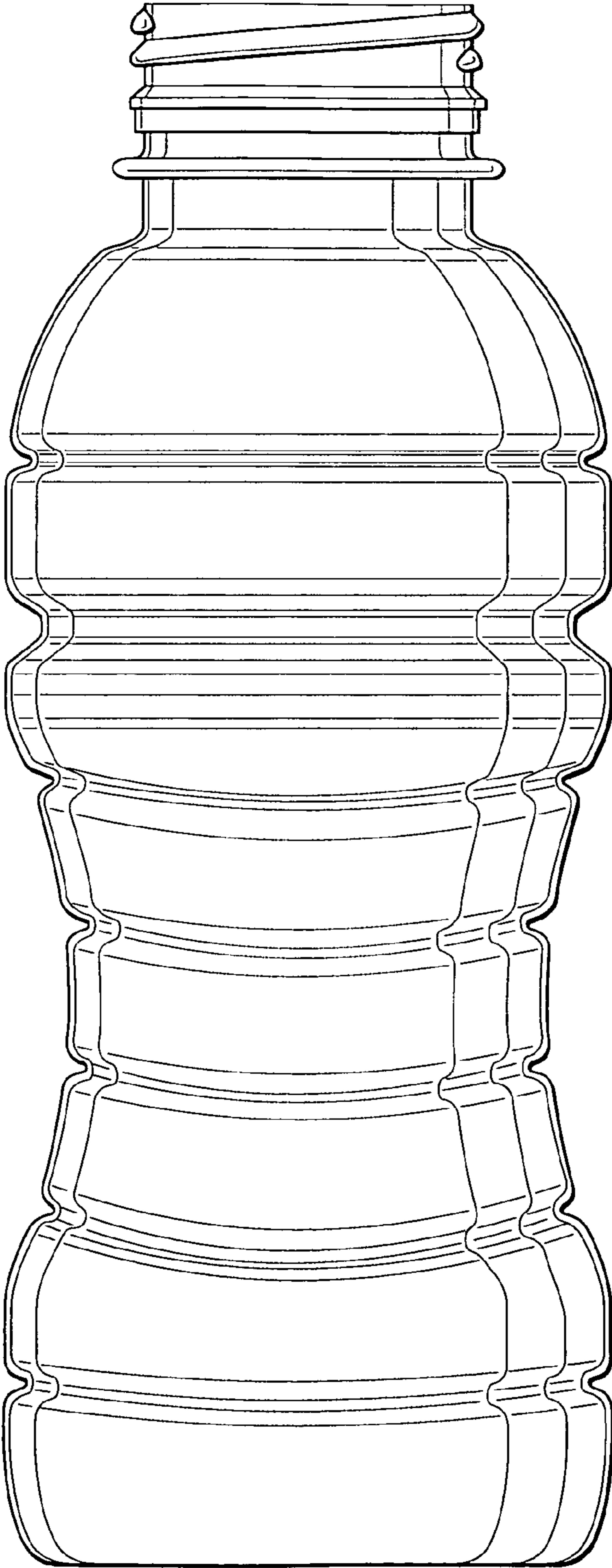

Fig. 4

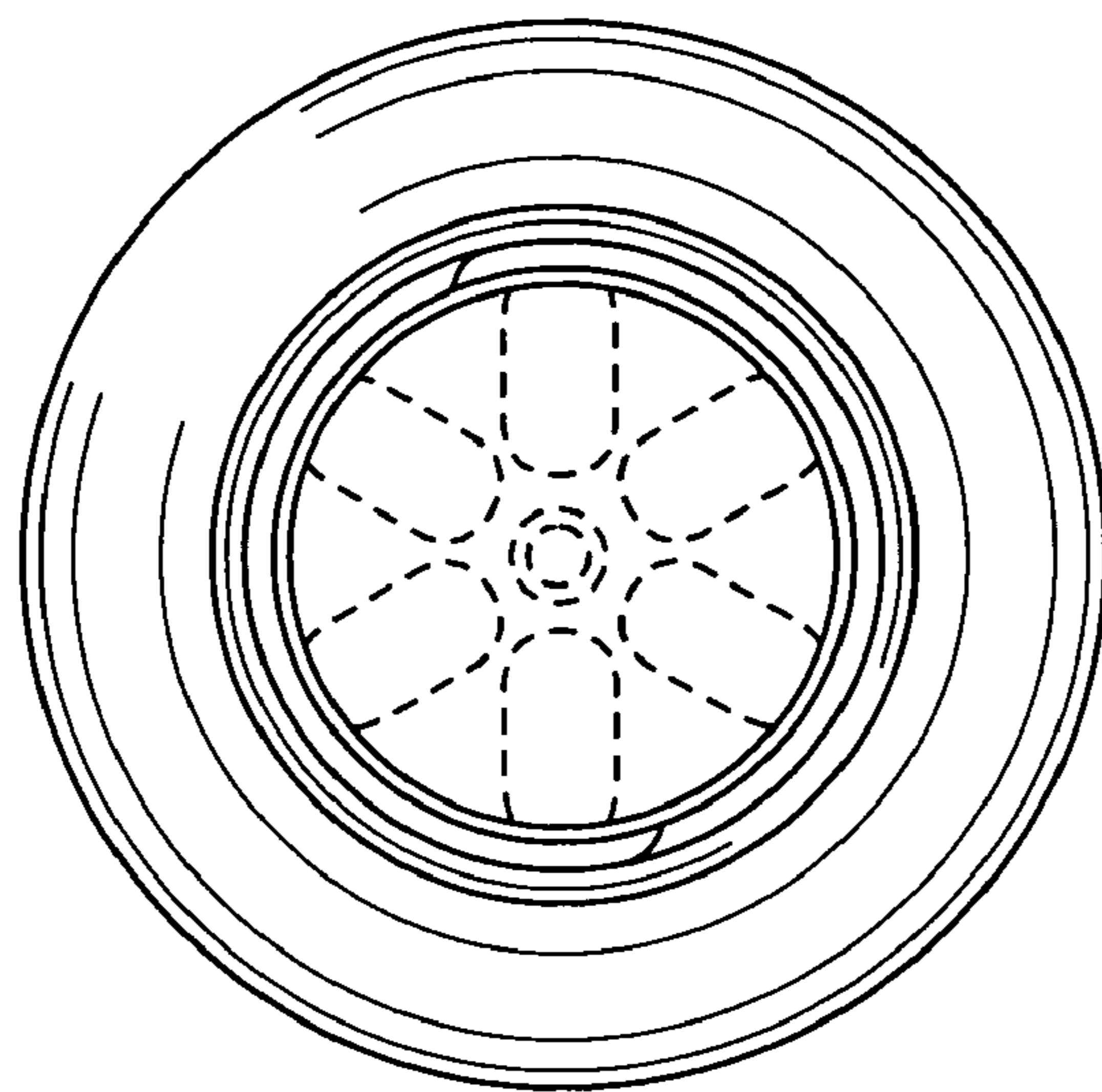

Fig. 5

