



US00D609033S

(12) **United States Design Patent**  
**Palumbo**

(10) **Patent No.:** **US D609,033 S**

(45) **Date of Patent:** **\*\* Feb. 2, 2010**

(54) **SEAT ARM**

(75) Inventor: **Stephen Palumbo**, McHenry, IL (US)

(73) Assignee: **Synergy Home Furnishings, LLC**,  
Ripley, MS (US)

(\*\*) Term: **14 Years**

(21) Appl. No.: **29/335,919**

(22) Filed: **Apr. 24, 2009**

(51) **LOC (9) Cl.** ..... **06-01**

(52) **U.S. Cl.** ..... **D6/492**

(58) **Field of Classification Search** ..... D6/334,  
D6/349, 355, 364, 370, 374, 378, 381, 382,  
D6/383, 491, 492, 495, 500–503; 297/68,  
297/232, 233, 353, 445.1, 448.1, 448.2, DIG. 7;  
5/12.1, 12.2

See application file for complete search history.

(56) **References Cited**

**U.S. PATENT DOCUMENTS**

- 2,087,574 A \* 7/1937 Kaufer ..... 297/113
- 2,774,977 A \* 12/1956 Mintz ..... 5/12.1
- D226,386 S \* 2/1973 DiPersia ..... D14/215
- D228,595 S \* 10/1973 Korch ..... D6/334

**OTHER PUBLICATIONS**

Ello Sectional, Chicago Merchandise Mart, known as of Apr. 6, 2005.  
Giorgio Sofa, High Point Furniture Market Showroom, known as of  
Apr. 2008 (sketch rendition and partial photograph).

Sunset International Advertisement, Furniture Today, known as of  
Oct. 22, 2008.

\* cited by examiner

*Primary Examiner*—Sandra Snapp

(74) *Attorney, Agent, or Firm*—Womble Carlyle Sandridge &  
Rice, PLLC

(57) **CLAIM**

The ornamental design for a seat arm, as shown and  
described.

**DESCRIPTION**

FIG. 1 is a left front perspective view of a new seat arm  
showing my new design in a representative embodiment;

FIG. 2 is a left side elevational view shown in a representative  
embodiment;

FIG. 3 is a front elevational view shown in a representative  
embodiment;

FIG. 4 is a partial right front perspective view shown in a  
representative embodiment; and,

FIG. 5 is a left front perspective view shown in a representa-  
tive embodiment.

The views of the seat arm not shown form no part of the  
claimed design. The broken lines shown in the drawings  
represent a variety of environments, environments of varying  
lengths, or portions thereof and form no part of the claimed  
design. The dotted lines on the top part of the seat arm rep-  
resent continuous stitching. The base is shown broken-away  
to indicate indeterminate width.

**1 Claim, 5 Drawing Sheets**

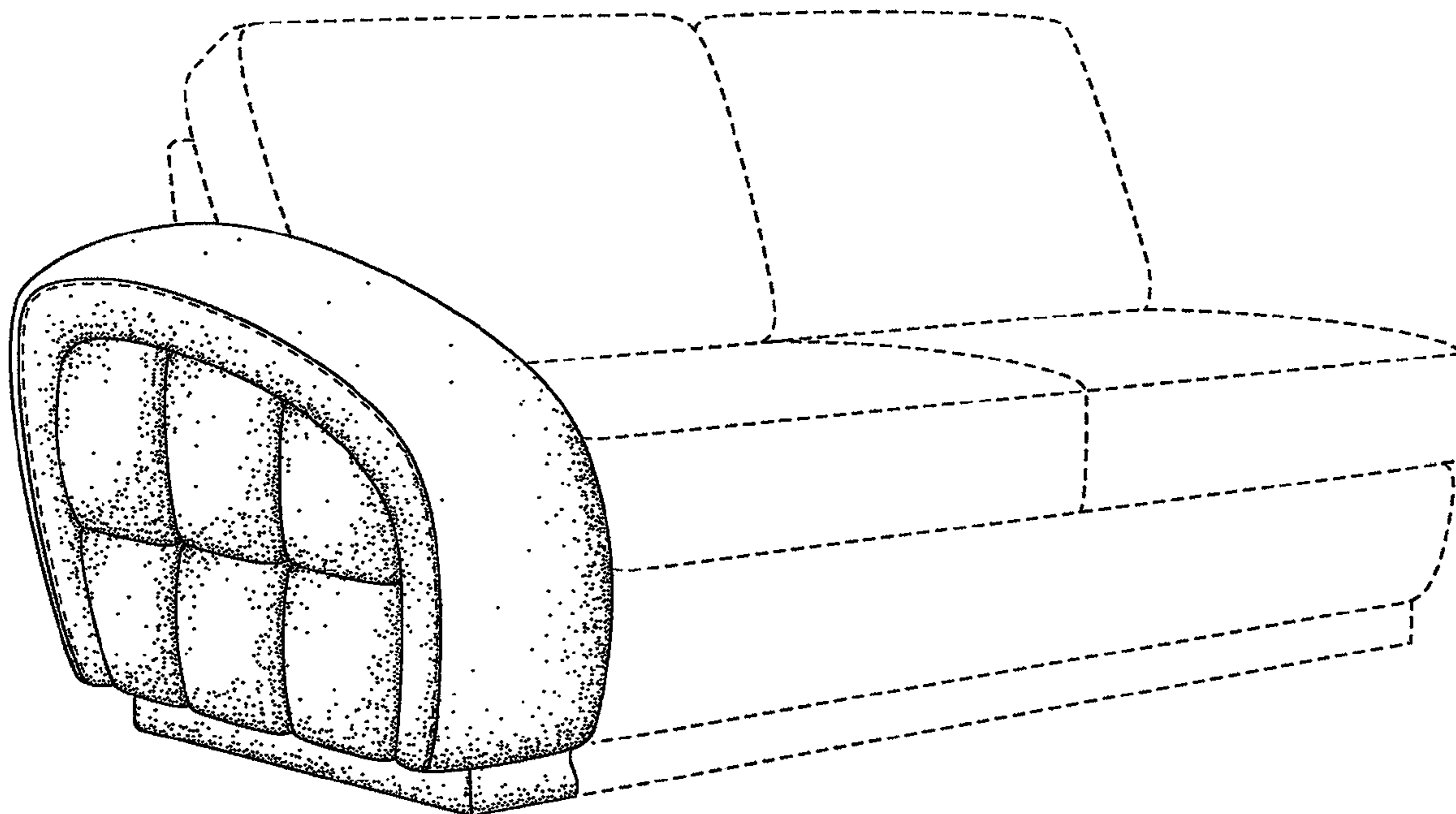

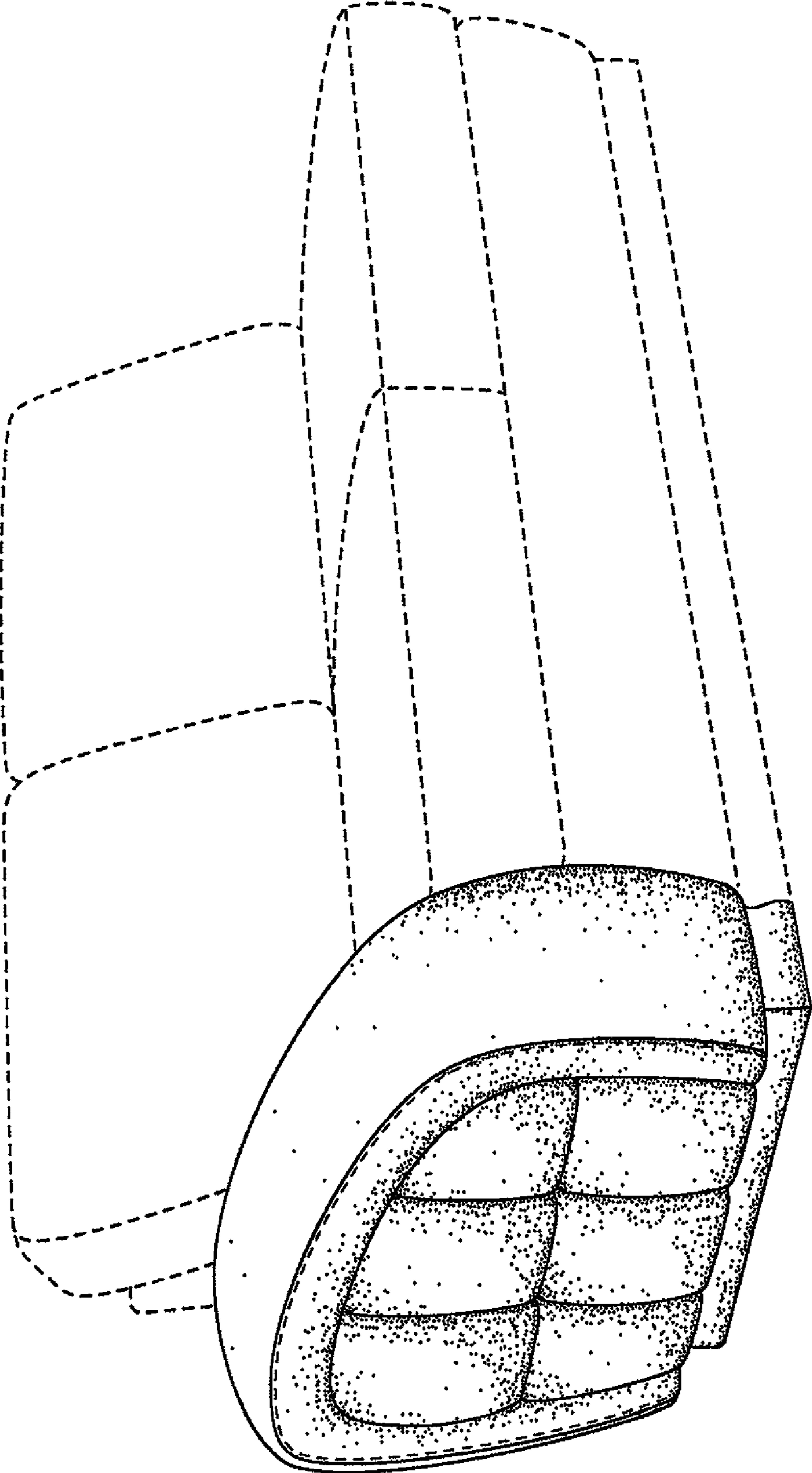

FIG. 1

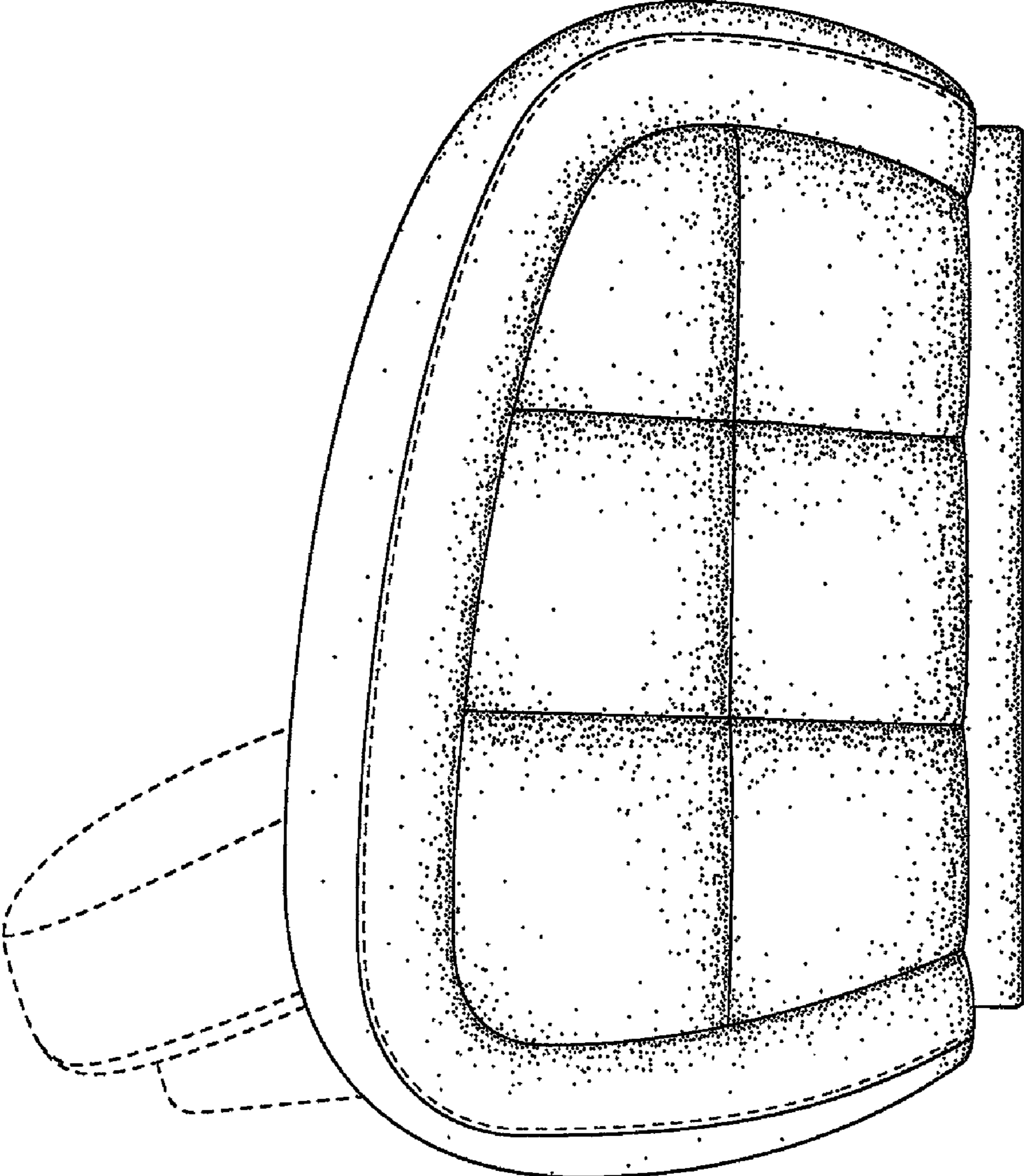

FIG. 2

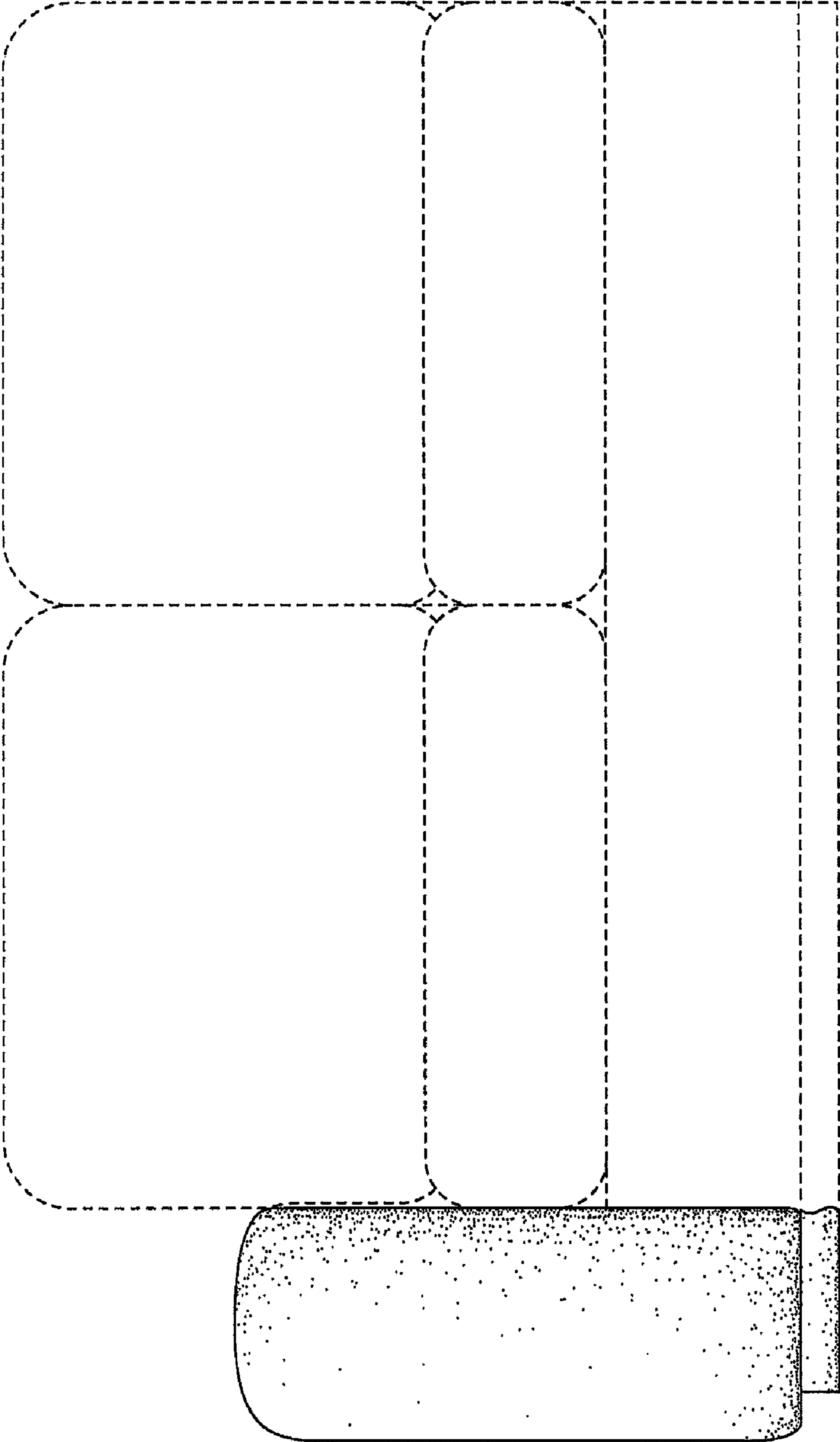

FIG. 3



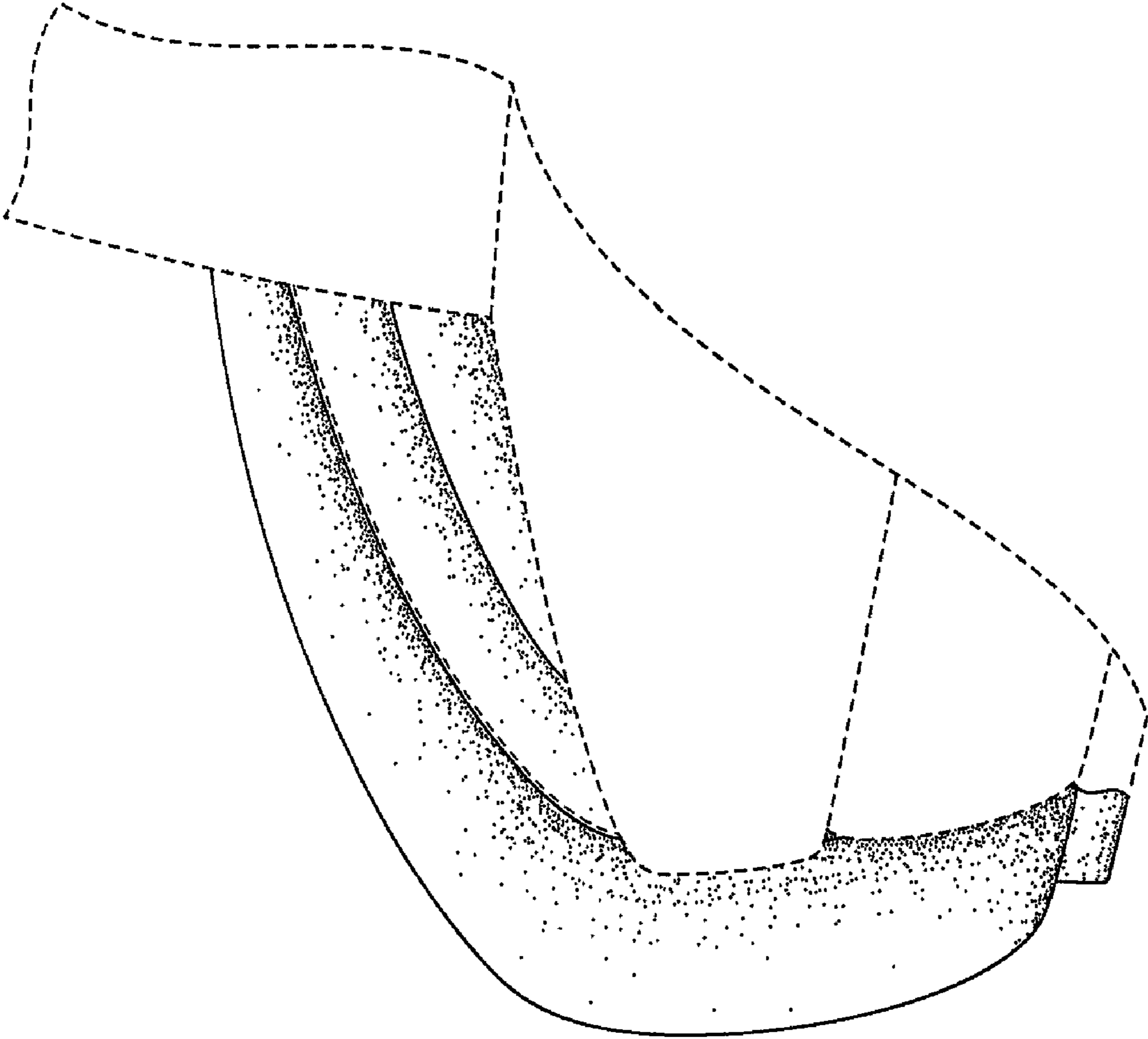

FIG. 4

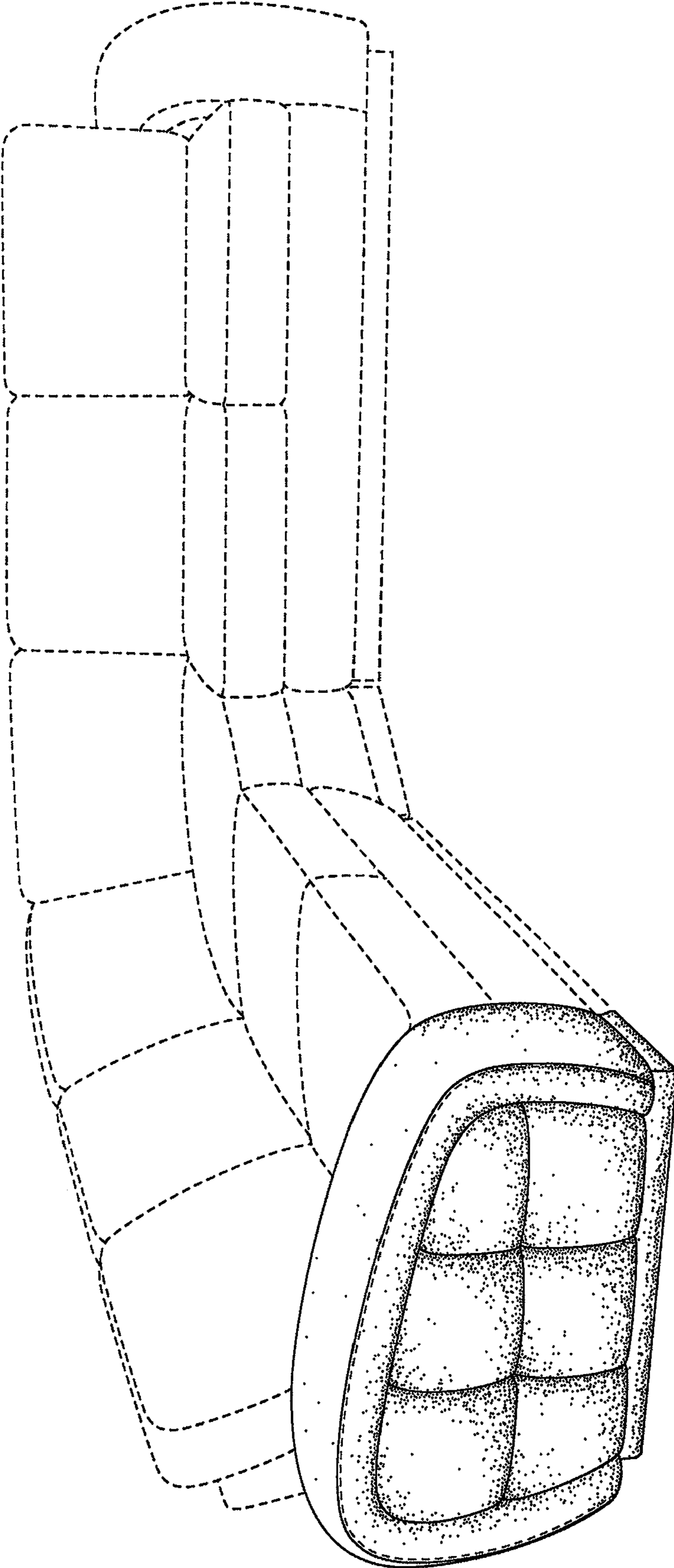

FIG. 5