



US00D608790S

(12) **United States Design Patent**
Canu-Chiesa

(10) **Patent No.:** **US D608,790 S**
(45) **Date of Patent:** **** Jan. 26, 2010**

(54) **AIRCRAFT NAVIGATION ICON FOR A DISPLAY SCREEN**

D594,469 S * 6/2009 Canu-Chiesa D14/492
2003/0025719 A1 2/2003 Palmer et al.

(Continued)

(75) Inventor: **Simona Canu-Chiesa**, Massac Seran (FR)

OTHER PUBLICATIONS

(73) Assignee: **Airbus Operations S.A.S.**, Toulouse Cedex (FR)

Logo Lounge, by Catharine Fishel and Bill Gardner, Rockport Publishers, Gloucester, MA © 2003, p. 339 item A.
1000 Icons, Symbols and Pictograms: Visual Communication for Every Language, by Blackcoffee, Rockport Publishers, Gloucester, MA © 2006, p. 17.

(**) Term: **14 Years**

(Continued)

(21) Appl. No.: **29/337,293**

Primary Examiner—Cathron C Brooks

(22) Filed: **May 19, 2009**

Assistant Examiner—Karen E Kearney

(74) *Attorney, Agent, or Firm*—Osler, Hoskin & Harcourt LLP

Related U.S. Application Data

(62) Division of application No. 29/281,119, filed on Jun. 15, 2007, now Pat. No. Des. 594,469.

(57) **CLAIM**

(51) **LOC (9) Cl.** **32-00**

The ornamental design for an aircraft navigation icon for a display screen, as shown and described.

(52) **U.S. Cl.** **D14/492**

(58) **Field of Classification Search** D14/485–495;
D18/26, 31–33; D20/11–12, 23–25, 29–32,
D20/36–38; 715/700–867, 973–977
See application file for complete search history.

DESCRIPTION

FIG. 1 is a front view showing an aircraft navigation icon for a display screen, shown separately from a portion of a display screen and at an enlarged scale for clarity of illustration, according to a first embodiment of my design;

(56) **References Cited**

U.S. PATENT DOCUMENTS

| | | | | |
|-----------|------|---------|------------------|---------|
| 3,546,676 | A | 12/1970 | Ragen | |
| D255,247 | S | 6/1980 | Lindsay | |
| D278,804 | S | 5/1985 | Tanikawa | |
| D341,848 | S | 11/1993 | Bigelow et al. | |
| 5,657,462 | A * | 8/1997 | Brouwer et al. | 715/709 |
| 5,727,174 | A | 3/1998 | Aparicio et al. | |
| 5,818,462 | A * | 10/1998 | Marks et al. | 715/723 |
| D435,257 | S | 12/2000 | Woods | |
| D474,197 | S | 5/2003 | Nguyen | |
| 7,155,675 | B2 * | 12/2006 | Billmaier et al. | 715/720 |
| 7,176,937 | B2 | 2/2007 | Gannon | |
| D553,196 | S | 10/2007 | Canon | |
| 7,423,628 | B2 | 9/2008 | Chyc et al. | |

FIG. 2 is a front view of the aircraft navigation icon for a display screen of FIG. 1;

FIG. 3 is a front view showing an aircraft navigation icon for a display screen, shown separately from a portion of a display screen and at an enlarged scale for clarity of illustration, according to a second embodiment of my design; and,

FIG. 4 is a front view of the aircraft navigation icon for a display screen of FIG. 3.

The broken lines showing the display screen and various portions thereof are for the purpose of illustrating unclaimed portions and form no part of the claimed design.

1 Claim, 4 Drawing Sheets

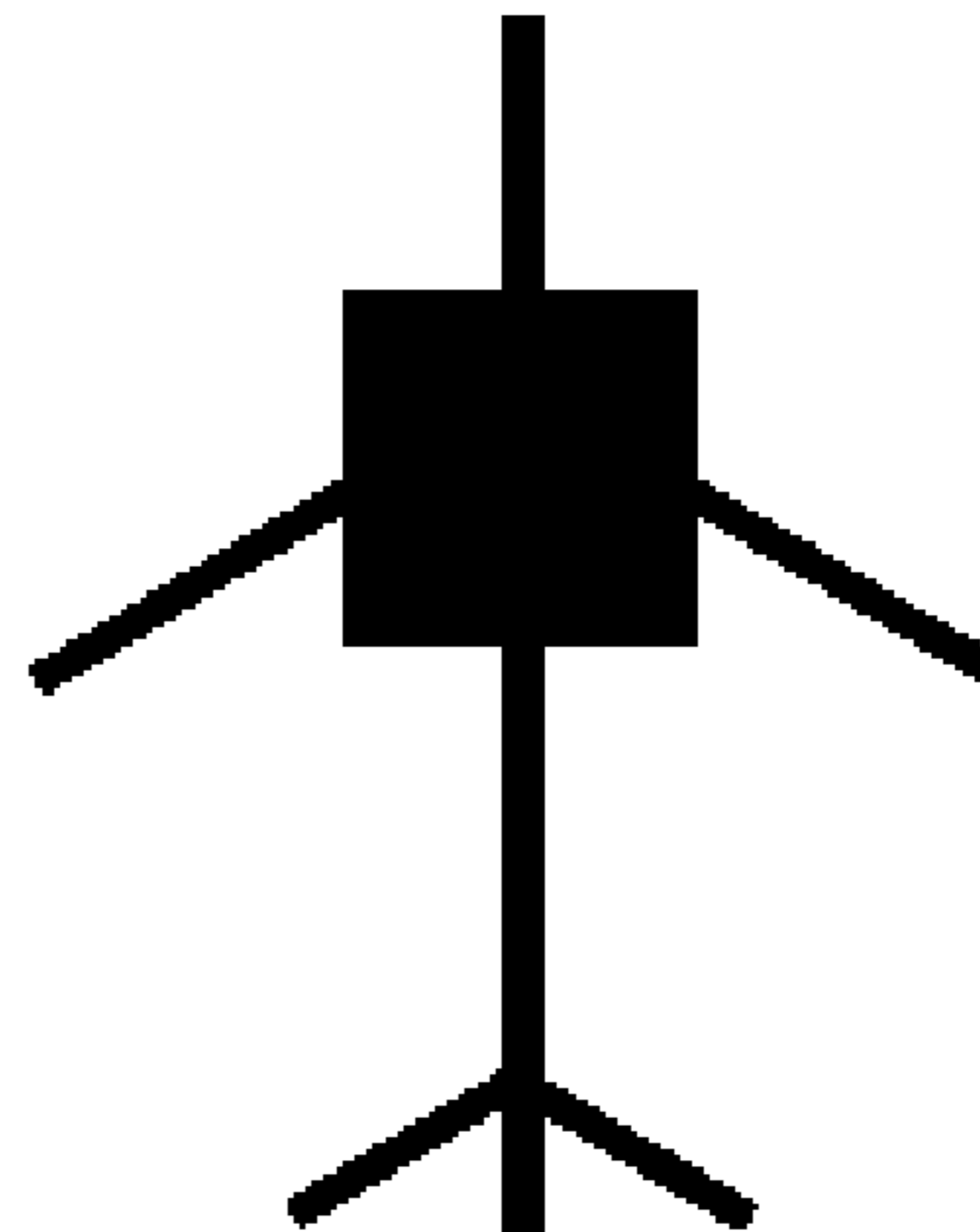
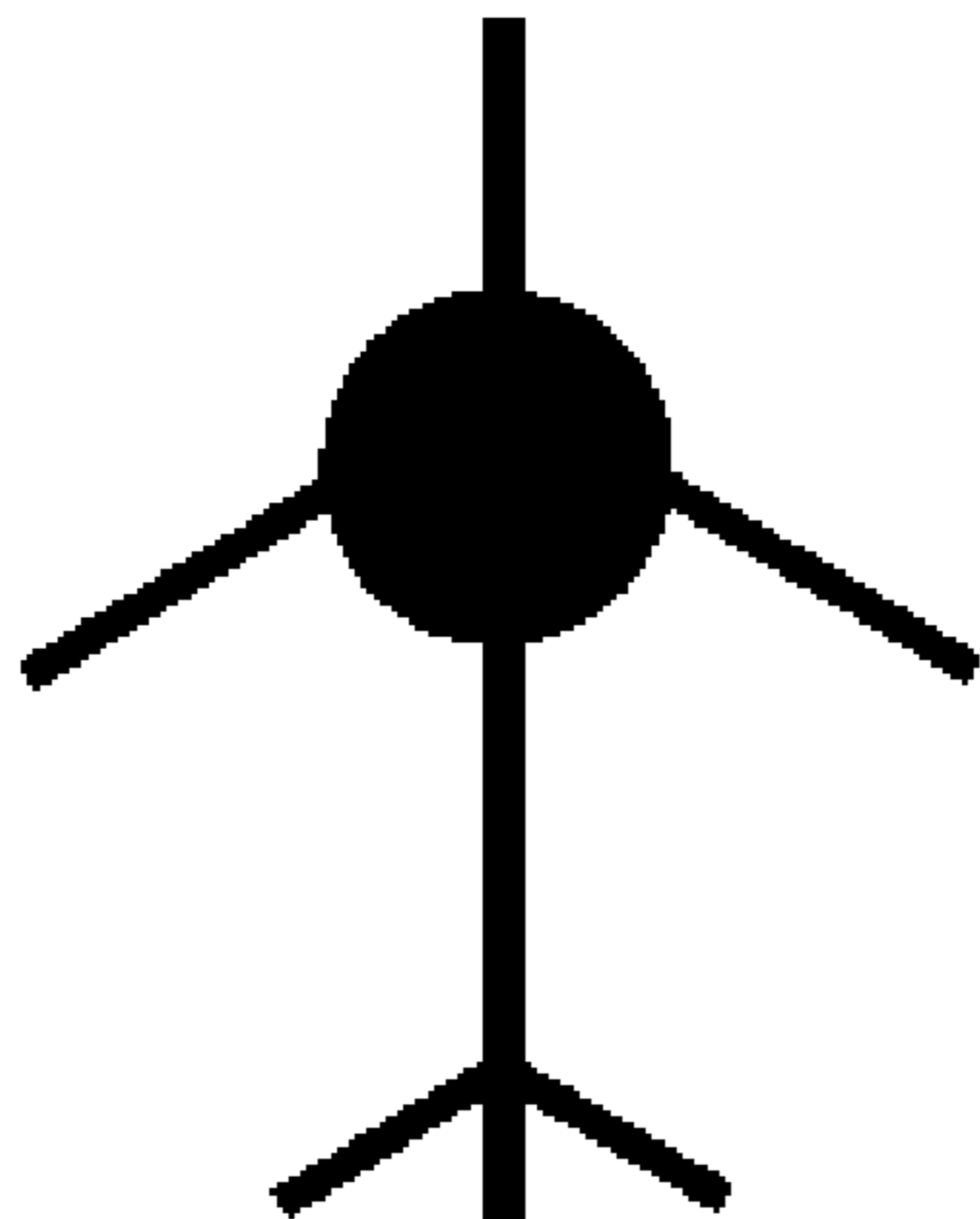

US D608,790 S

Page 2

U.S. PATENT DOCUMENTS

2003/0174177 A1 9/2003 Tsukuda et al.
2006/0265109 A1 11/2006 Canu-Chiesa et al.
2008/0270905 A1* 10/2008 Goldman 715/721

OTHER PUBLICATIONS

Symbol Source Book, by Henry Dreyfuss, Van Nostrand Reinhold Company, New York, NY © 1972, pp. 71, 83, 170, 205.

* cited by examiner

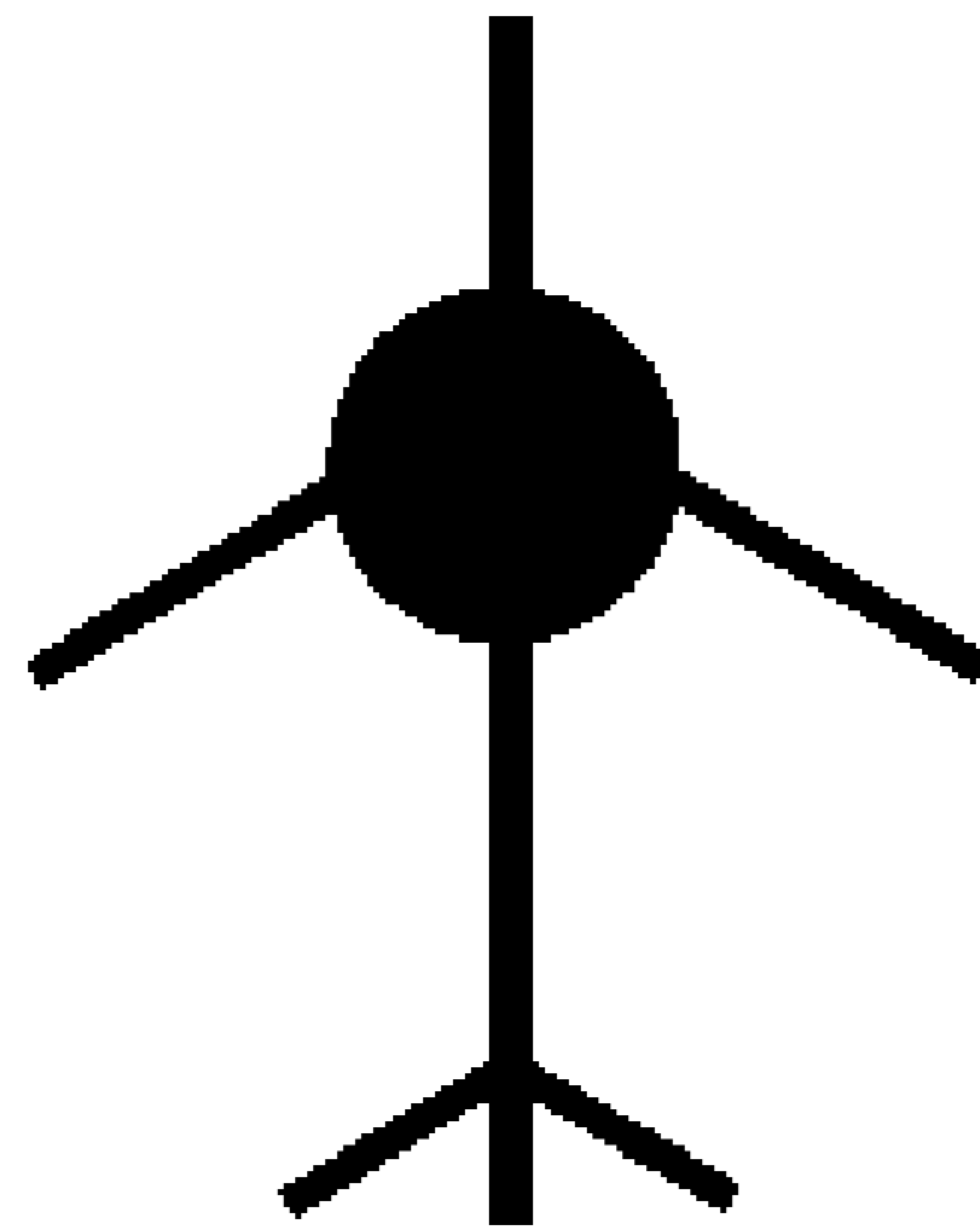

FIG. 1

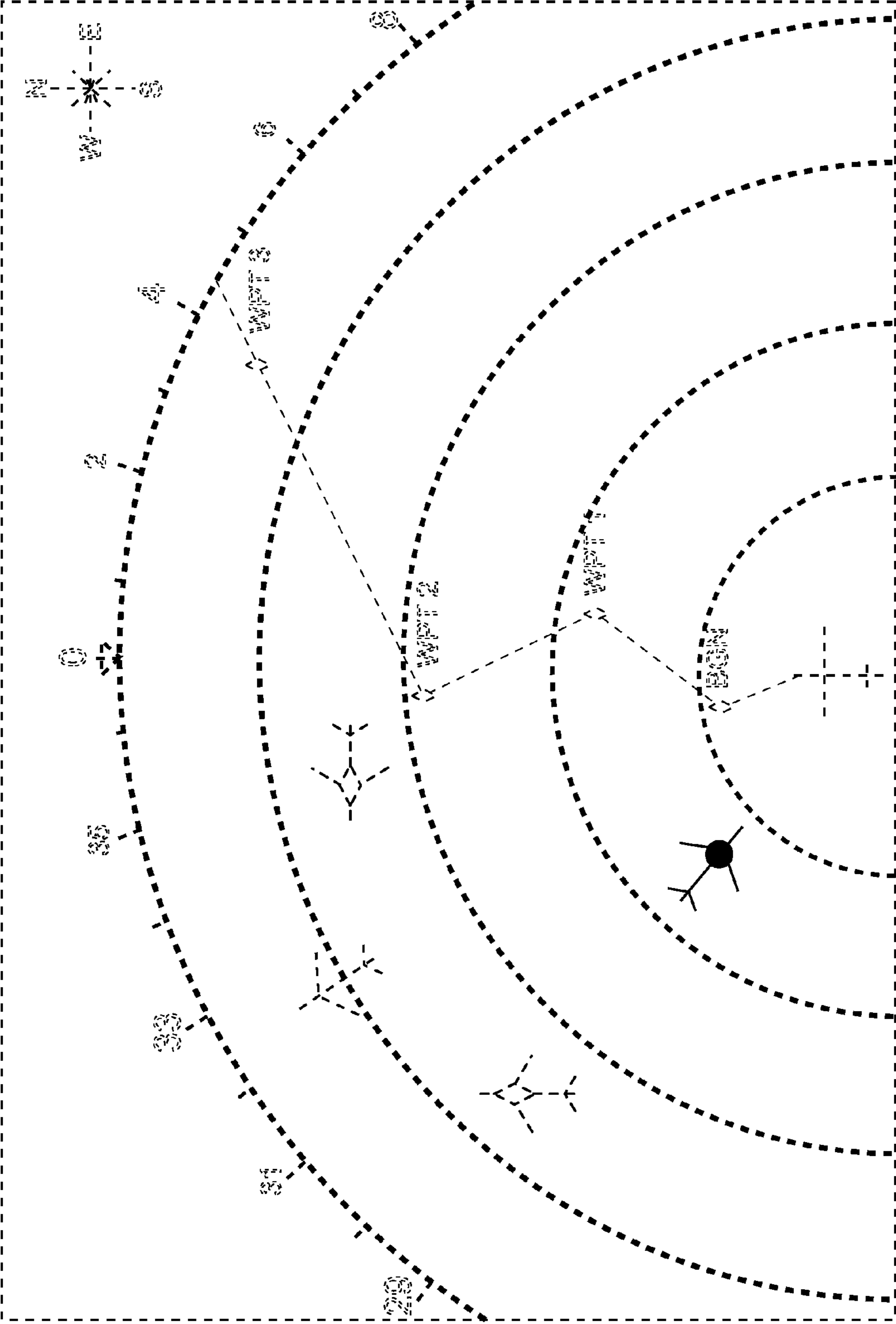

FIG. 2

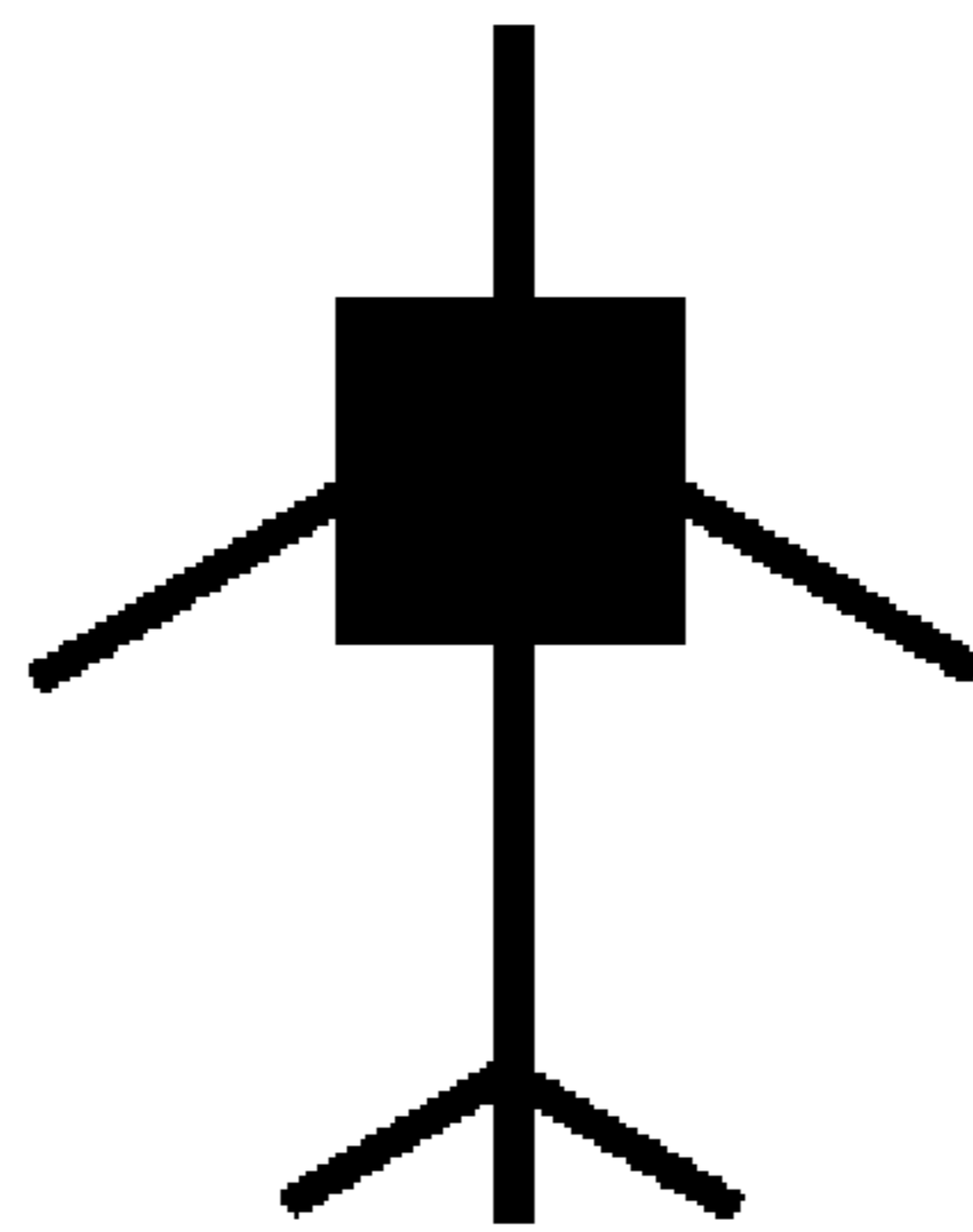

FIG. 3

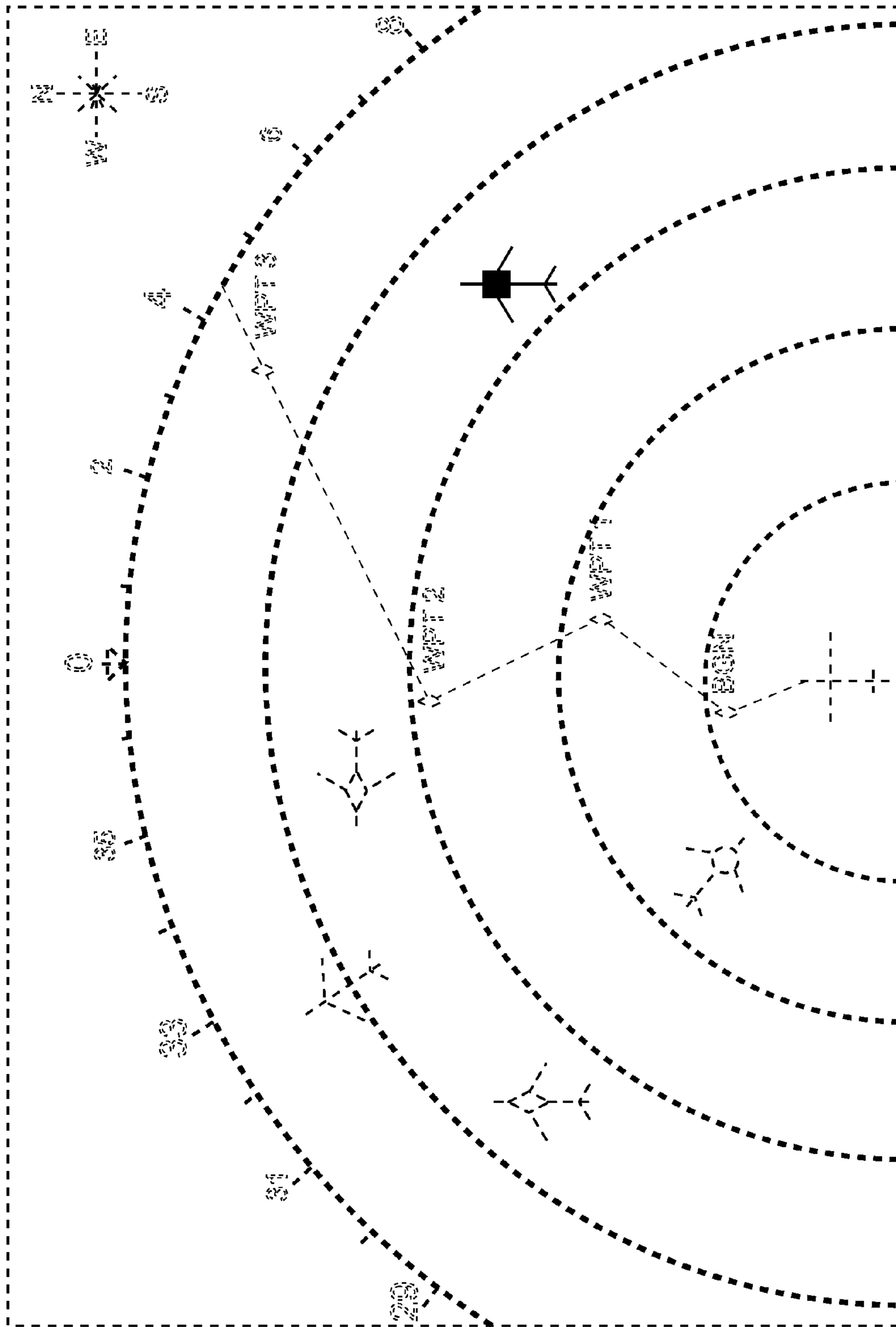

FIG. 4