

US00D608710S

(12) **United States Design Patent**  
**Nissl**

(10) **Patent No.:** **US D608,710 S**  
(45) **Date of Patent:** **\*\* Jan. 26, 2010**

(54) **WHEEL OR WHEEL COVER**  
(75) Inventor: **Florian Dieter Nissl**, Munich (DE)  
(73) Assignee: **Bayerische Motoren Werke Aktiengesellschaft**, Munich (DE)  
(\*\*) Term: **14 Years**  
(21) Appl. No.: **29/311,560**  
(22) Filed: **Apr. 20, 2009**

D534,473 S 1/2007 Bernoni  
D542,728 S 5/2007 Ichinose  
D553,069 S 10/2007 Ettensberger  
D558,118 S 12/2007 Hueller  
D570,761 S 6/2008 Antoniadis et al.  
D589,428 S \* 3/2009 Scheu ..... D12/211  
D590,313 S 4/2009 Baum  
D590,314 S \* 4/2009 Hettler ..... D12/209  
D590,318 S \* 4/2009 Theiss ..... D12/211  
D590,757 S \* 4/2009 Froehlick ..... D12/209  
D591,661 S \* 5/2009 Baum ..... D12/209  
D593,017 S \* 5/2009 Antoniadis et al. .... D12/209  
D593,476 S \* 6/2009 Juergens et al. .... D12/211

(30) **Foreign Application Priority Data**  
Oct. 21, 2008 (DE) ..... 402008005147

(Continued)

(51) **LOC (9) Cl.** ..... **12-16**  
(52) **U.S. Cl.** ..... **D12/209**  
(58) **Field of Classification Search** ..... D12/204-213;  
301/37.101, 64.101, 65  
See application file for complete search history.

**FOREIGN PATENT DOCUMENTS**

DE 40704326.8 12/2007

*Primary Examiner*—Caron Veynar  
*Assistant Examiner*—Katrina A Kile  
(74) *Attorney, Agent, or Firm*—Crowell & Moring LLP

(56) **References Cited**  
**U.S. PATENT DOCUMENTS**

(57) **CLAIM**

The ornamental design for a wheel or wheel cover, as shown and described.

D339,561 S 9/1993 Maiworm et al.  
D348,243 S 6/1994 Echazabal et al.  
D402,251 S 12/1998 Timm  
D402,951 S 12/1998 Wechner  
D405,749 S 2/1999 Kulla  
D416,849 S 11/1999 Weidhase  
D419,948 S 2/2000 Cahyono  
D432,071 S 10/2000 Brown  
D432,974 S 10/2000 Jablonski  
D450,649 S 11/2001 Penzes  
D453,494 S 2/2002 Brown et al.  
D486,769 S 2/2004 Gallert  
D500,978 S 1/2005 Echazabal  
D502,677 S 3/2005 Baum  
D504,379 S 4/2005 Kern  
D521,438 S 5/2006 Nordmann  
D523,799 S 6/2006 Ianniello  
D526,947 S 8/2006 Kim  
D528,061 S 9/2006 Saridakis et al.  
D530,256 S 10/2006 Pfeiffer  
D532,739 S 11/2006 Ettensberger

**DESCRIPTION**

This application contains subject matter similar to the following co-pending U.S. patent application:

Application Ser. No. 29/300,128, filed Feb. 22, 2008.

FIG. 1 is a front view of a wheel or wheel cover according to my novel design; and,

FIG. 2 is a perspective view thereof.

The broken line showing of the rear portion of the wheel rim, central hub, and air valve area is included for the purpose of illustrating environment and form no part of the claimed design.

**1 Claim, 1 Drawing Sheet**

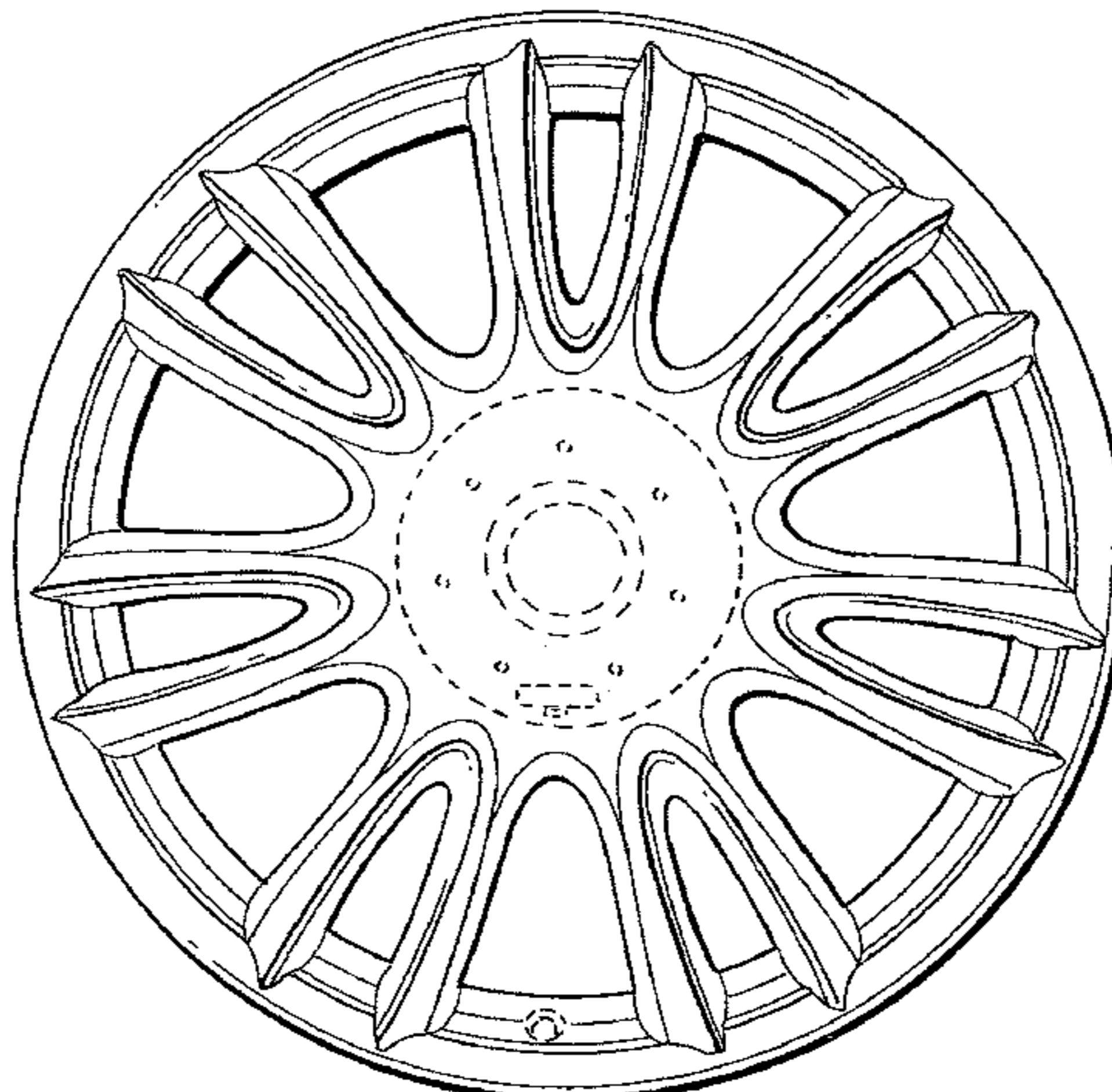

# US D608,710 S

Page 2

---

## U.S. PATENT DOCUMENTS

D597,015 S *	7/2009	Juergens et al. ....	D12/211	D598,834 S *	8/2009	Juergens et al. ....	D12/209
D597,464 S *	8/2009	Truebsbach .....	D12/211	2004/0145236 A1*	7/2004	Wang .....	301/37.101
							* cited by examiner

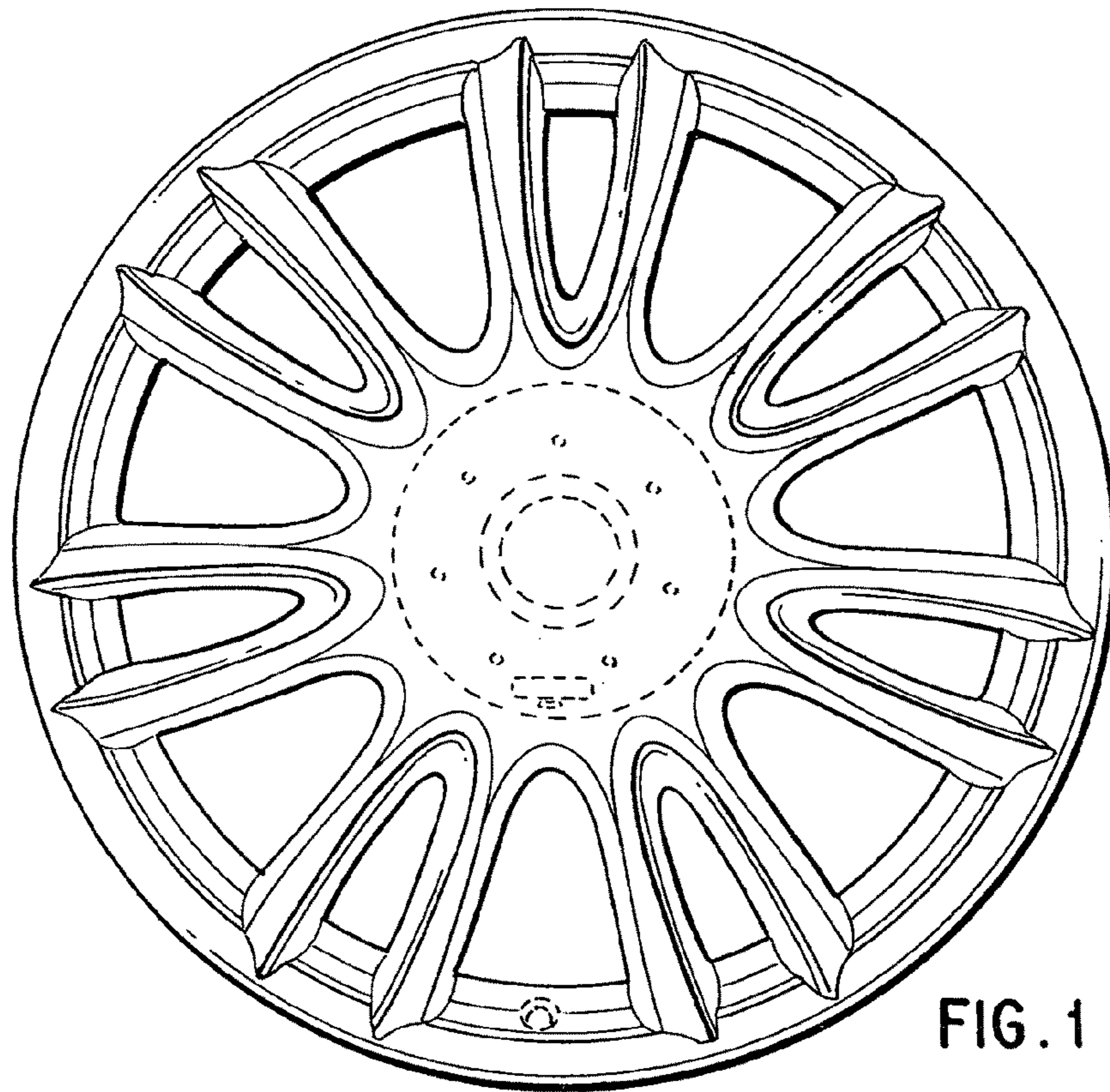

FIG. 1

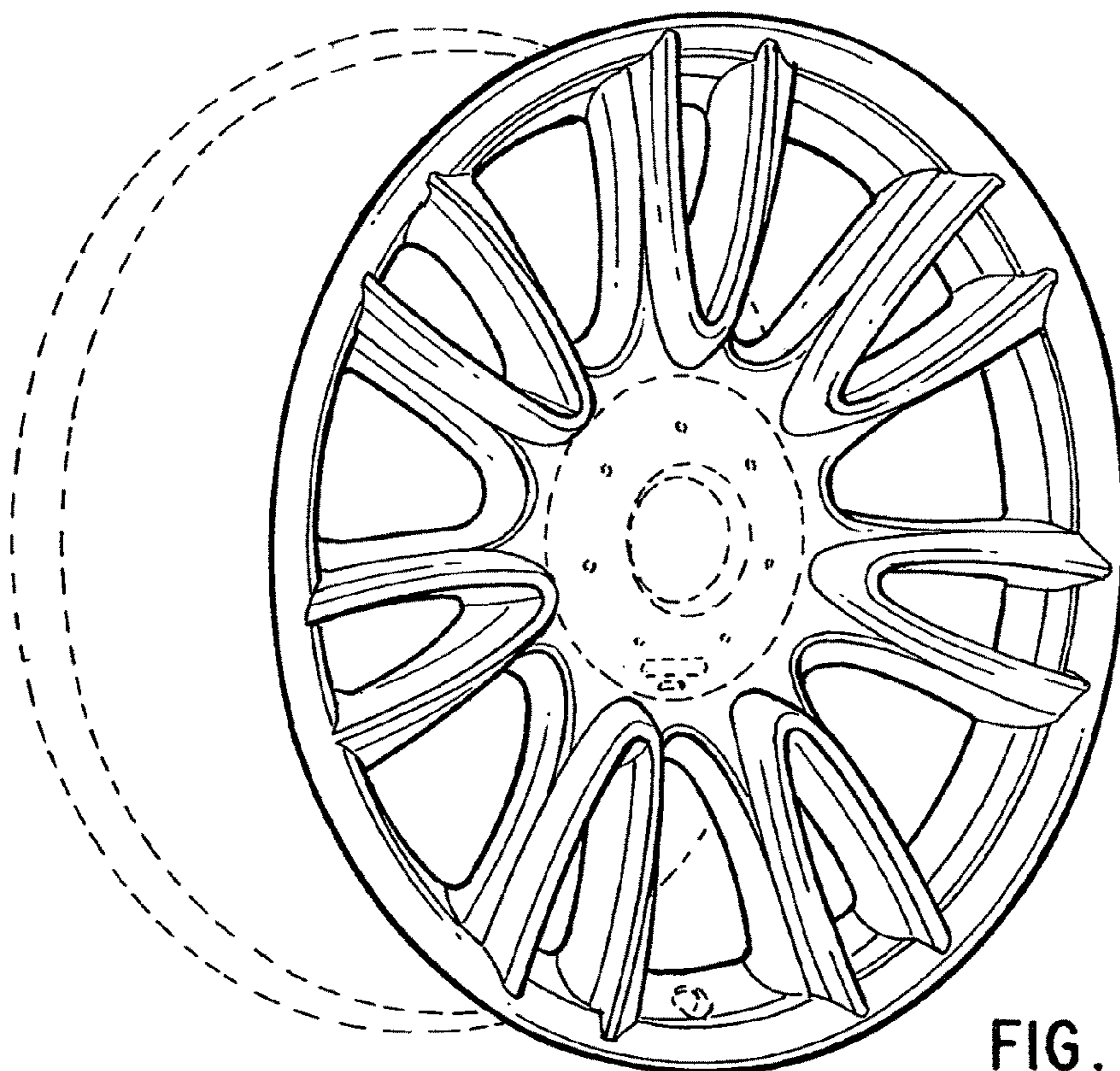

FIG. 2