



US00D608584S

(12) **United States Design Patent**
Picozza et al.

(10) **Patent No.:** **US D608,584 S**
(45) **Date of Patent:** **** Jan. 26, 2010**

(54) **COOKWARE**

(75) Inventors: **Augusto Picozza**, Boca Raton, FL (US);
Nancy Perkins, Dallas, TX (US); **Diana W. Juratovac**, Columbus, OH (US);
Elisabeth Sung-Eun Choi, Sungnam-si (KR)

(73) Assignee: **Sunbeam Products, Inc.**, Boca Raton, FL (US)

(**) Term: **14 Years**

(21) Appl. No.: **29/342,118**

(22) Filed: **Aug. 19, 2009**

(51) **LOC (9) Cl.** **07-02**

(52) **U.S. Cl.** **D7/354**

(58) **Field of Classification Search** D7/323,
D7/330-331, 339, 350-367, 378-379, 383-384,
D7/391, 392.1, 406, 542-545, 667; 99/324-325,
99/329 R, 330-339; 219/432-433, 438-441,
219/620-622, 725-730; 220/203.1, 203.7,
220/303, 573.1-574, 769, 912; 426/438,
426/441

See application file for complete search history.

(56) **References Cited**

U.S. PATENT DOCUMENTS

D197,476 S * 2/1964 De Puy D7/542
D270,323 S * 8/1983 Powers D7/543
D373,932 S * 9/1996 Onneweer D7/543

D483,989 S * 12/2003 Lillelund et al. D7/392.1
D486,999 S * 2/2004 de Groote et al. D7/667
D511,268 S * 11/2005 Ryan D7/360
D557,551 S * 12/2007 Tetreault et al. D7/354
D565,342 S * 4/2008 Ryan D7/354
D566,457 S * 4/2008 Ryan D7/360
D590,204 S * 4/2009 Tetreault et al. D7/354
D592,444 S * 5/2009 Tetreault D7/352
D594,704 S * 6/2009 Loaiza D7/542

* cited by examiner

Primary Examiner—Caron Veynar

Assistant Examiner—Ricky Pham

(74) *Attorney, Agent, or Firm*—Lawrence J. Shurupoff

(57) **CLAIM**

The ornamental design for a cookware, as shown and described.

DESCRIPTION

FIG. 1 is a front right perspective view of the cookware showing the new design;

FIG. 2 is a front elevation view thereof;

FIG. 3 is a back side elevation view thereof;

FIG. 4 is a right side elevation thereof;

FIG. 5 is a left side elevation thereof; and,

FIG. 6 is a top plan view thereof.

The broken lines in the drawings are for illustrative purposes only and form no part of the claimed design.

1 Claim, 3 Drawing Sheets

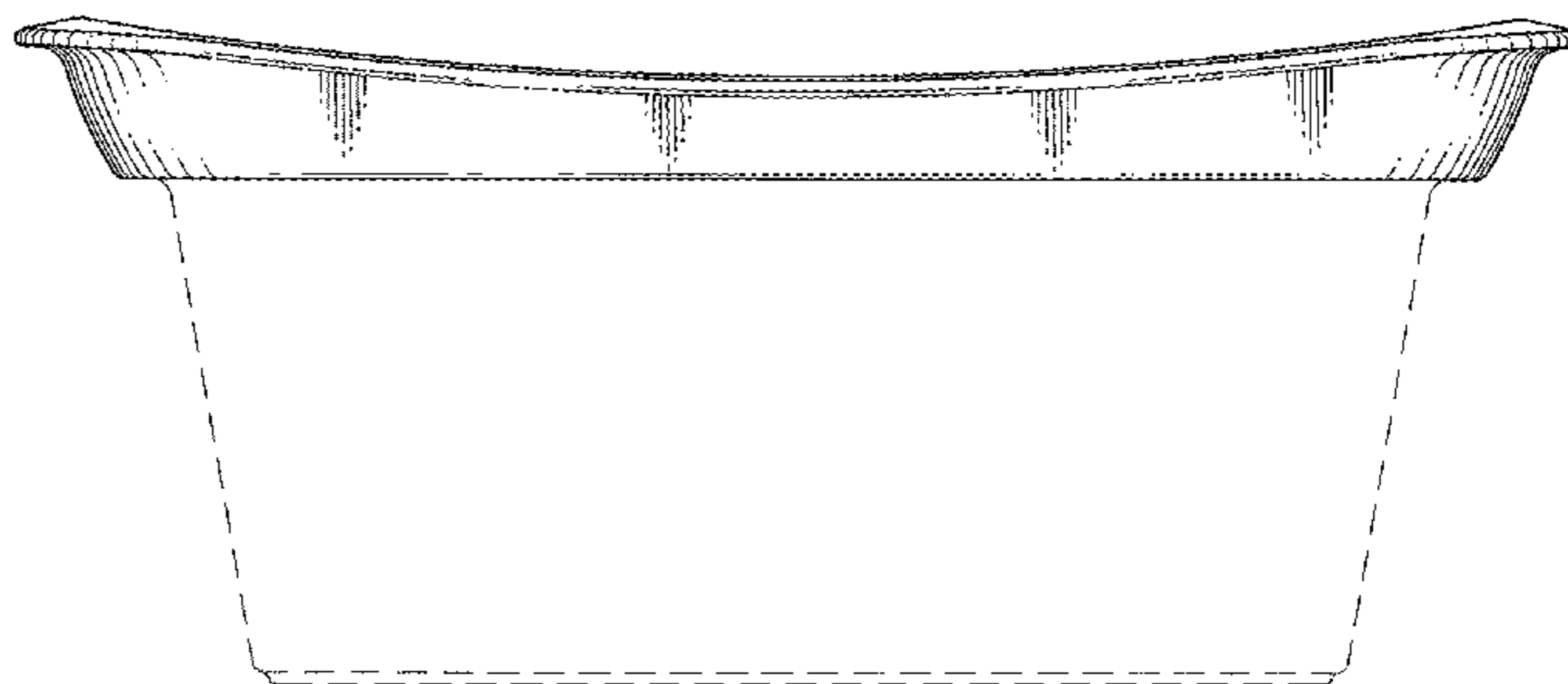
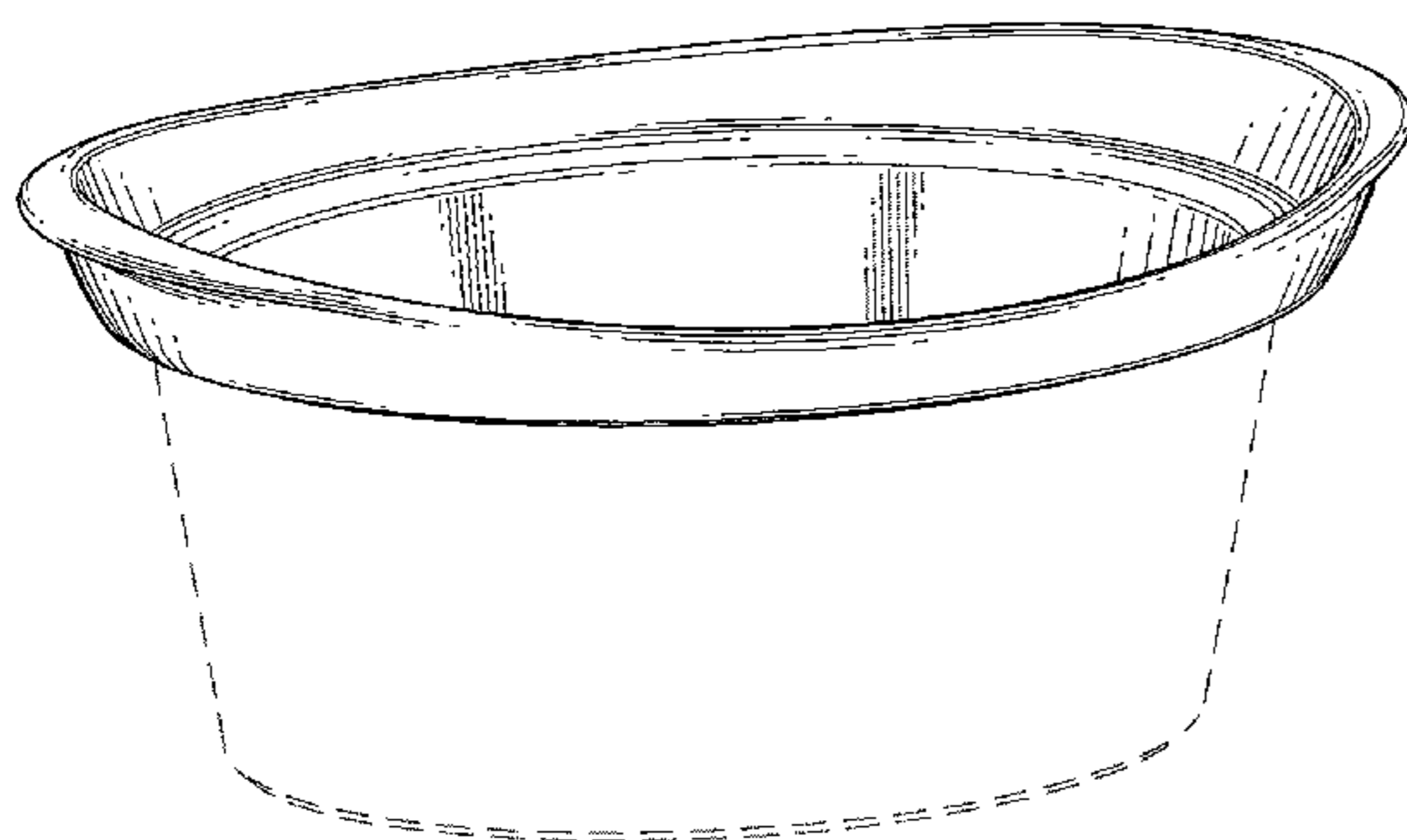

FIG. 1

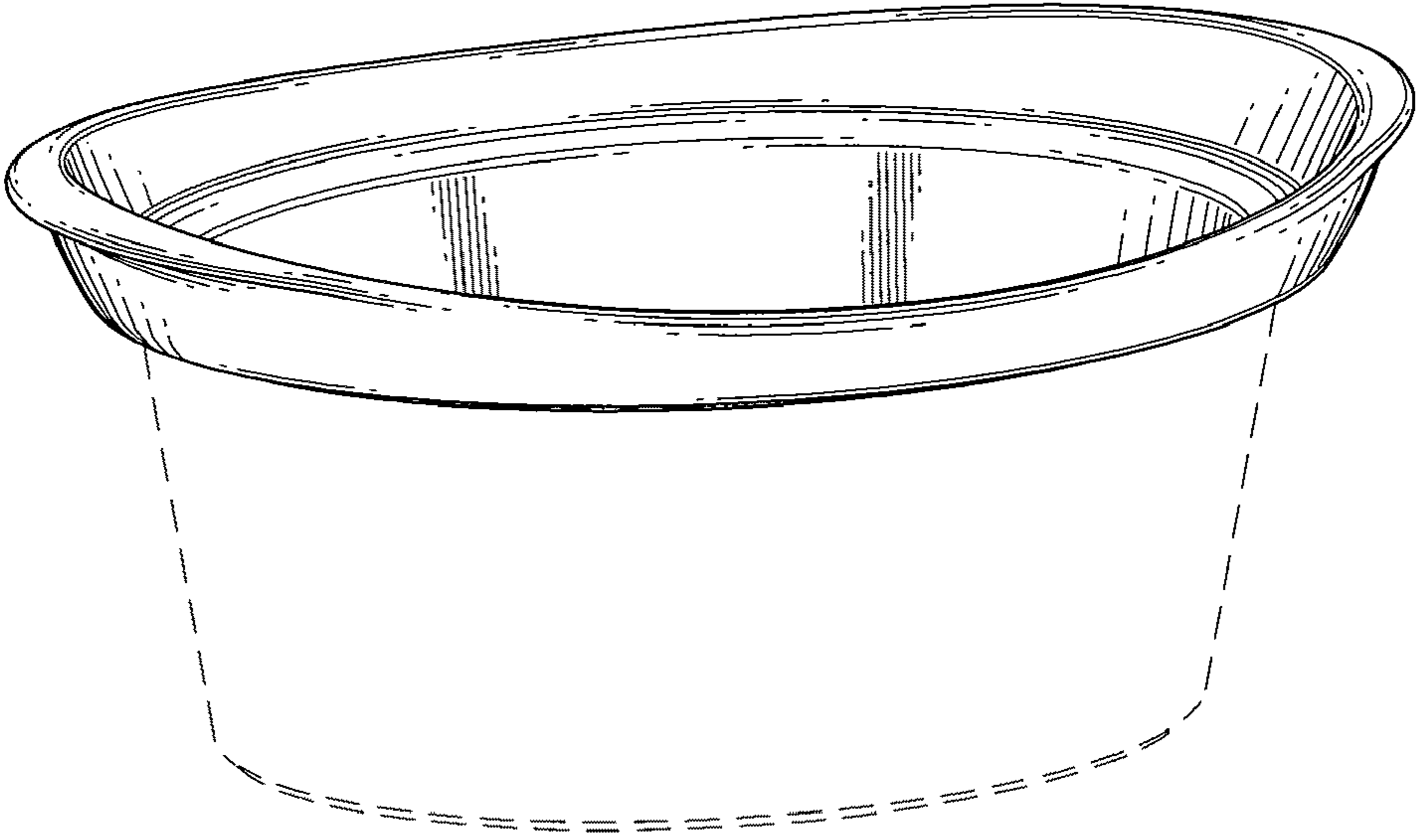

FIG. 2

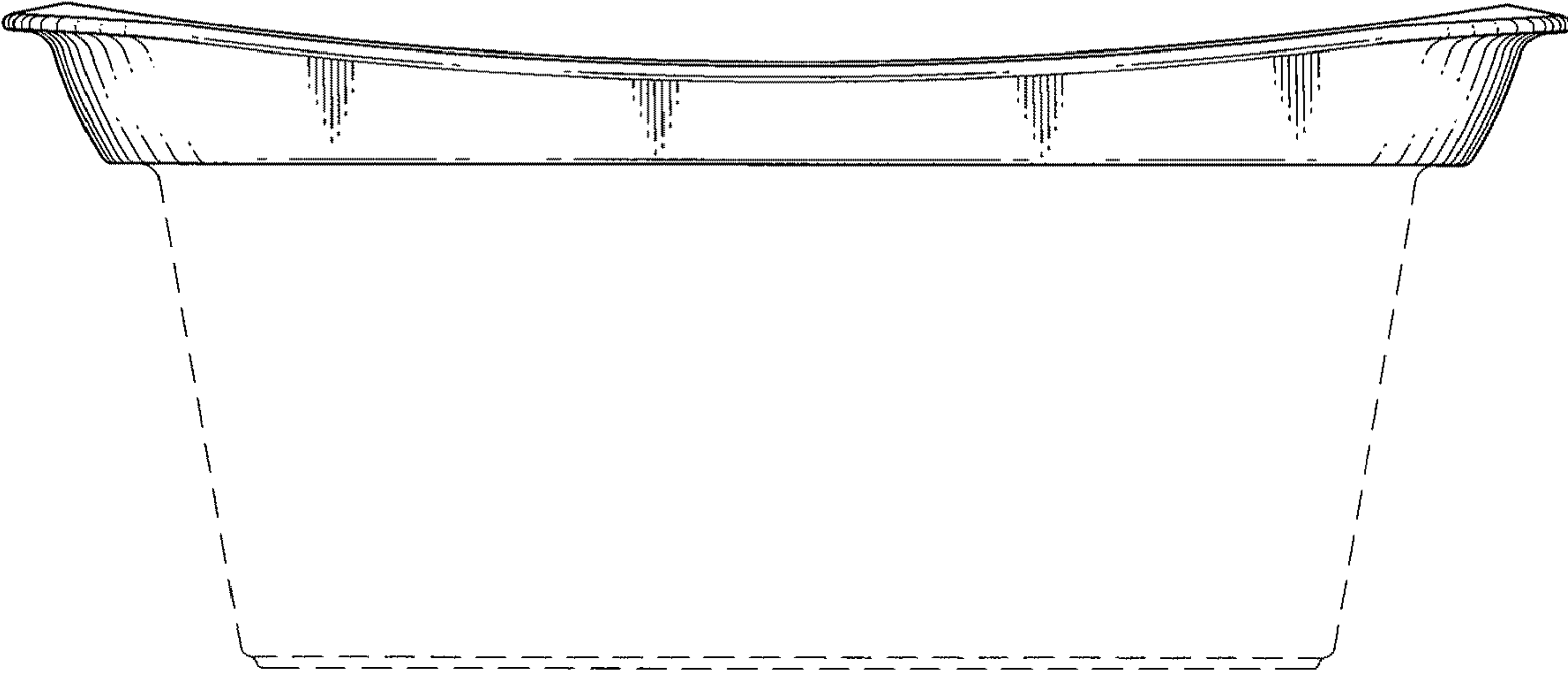

FIG. 3

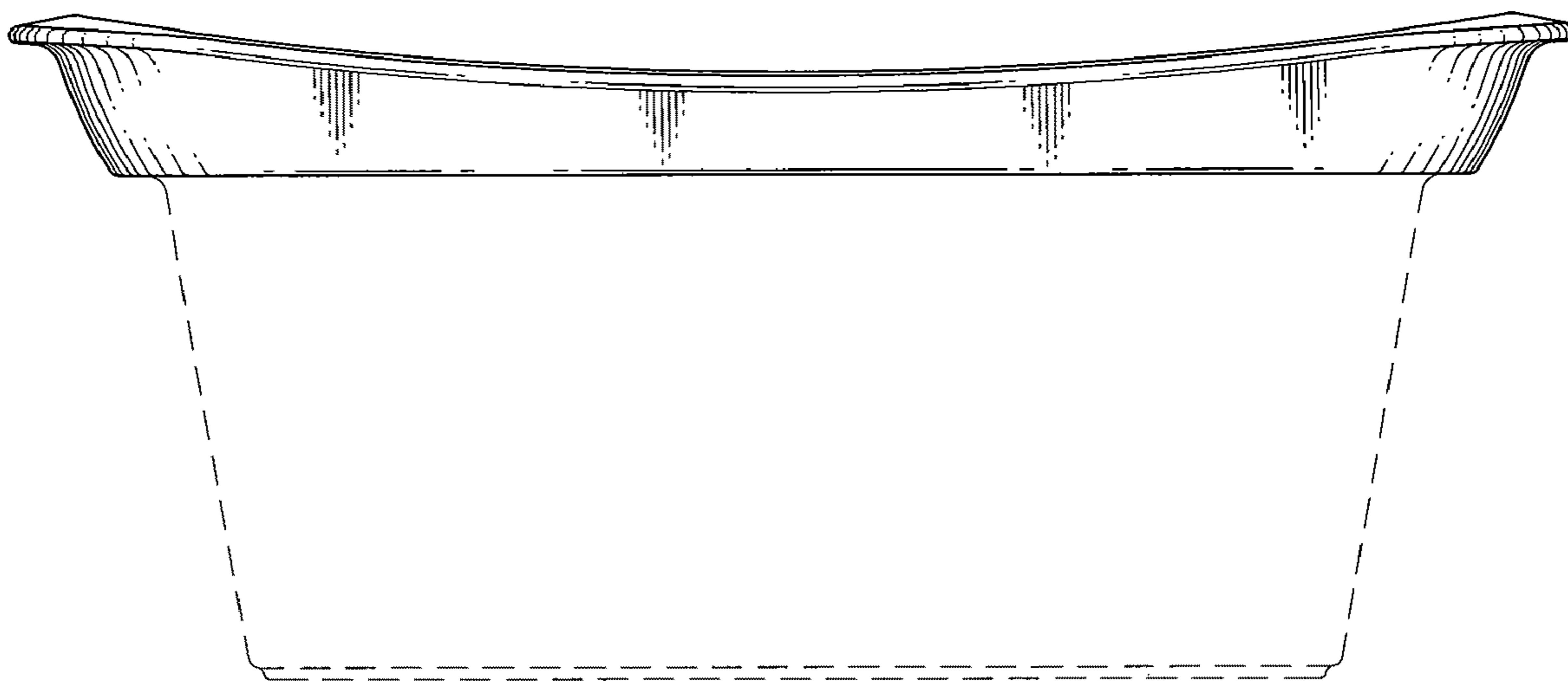

FIG. 4

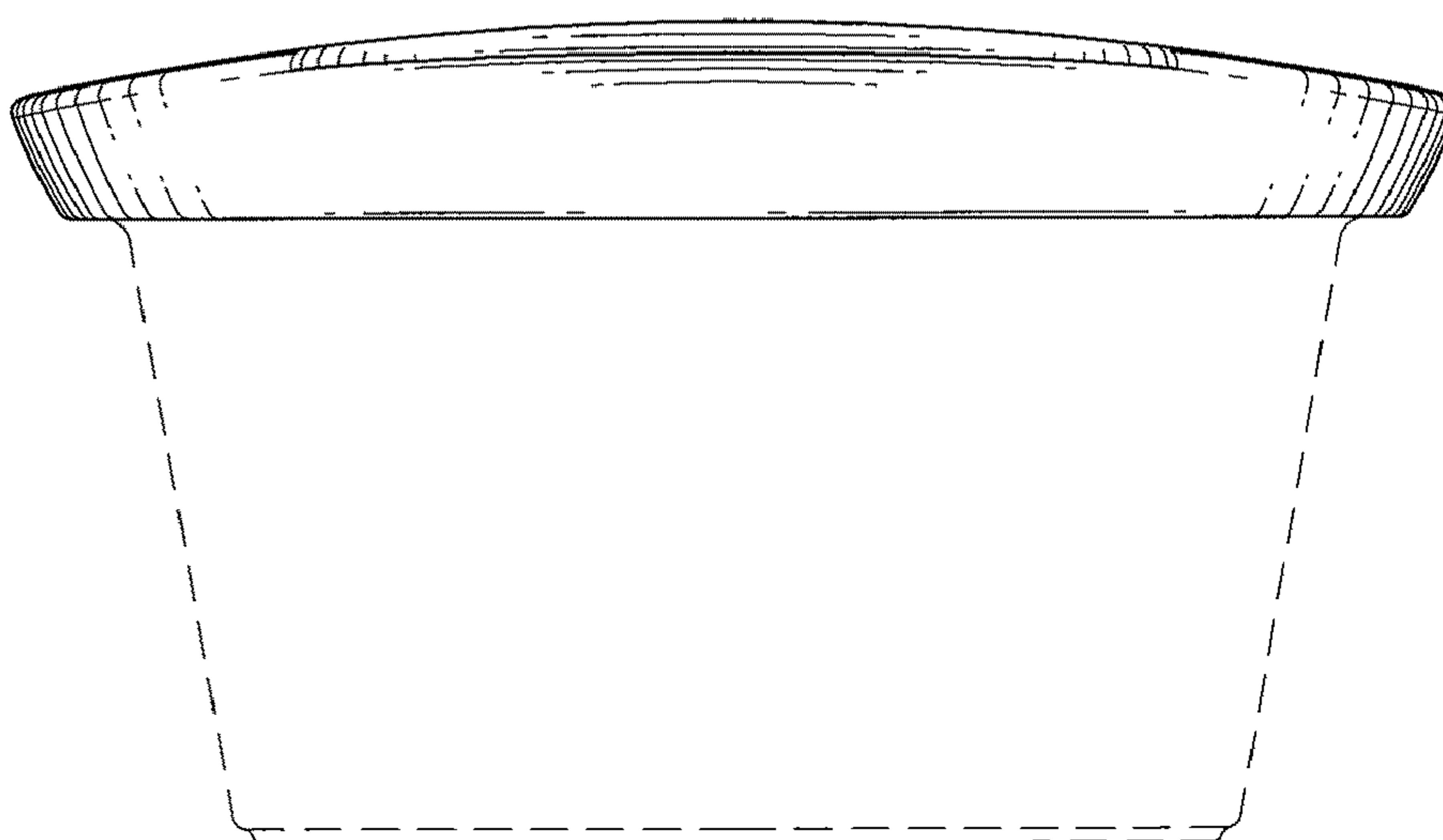

FIG. 5

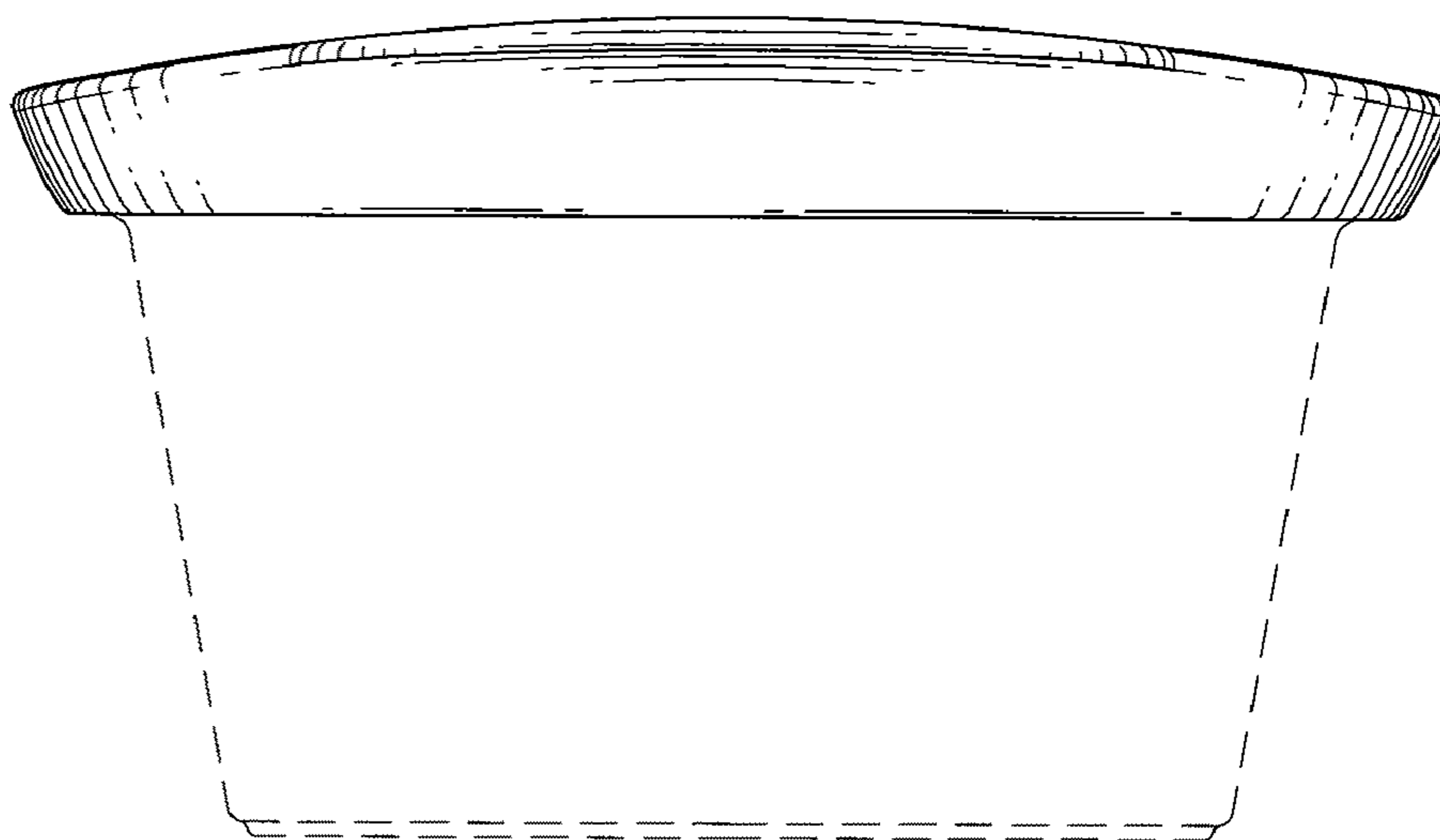

FIG. 6

