



US00D608521S

(12) **United States Design Patent**
Berger et al.

(10) **Patent No.:** **US D608,521 S**
(45) **Date of Patent:** **** Jan. 19, 2010**

(54) **REAR ENTRY PALLET TRUCK**

Primary Examiner—Cynthia E Ramirez
(74) *Attorney, Agent, or Firm*—Stevens & Showalter LLP

(75) Inventors: **Ryan R. Berger**, Columbus, OH (US);
Markus Graf, Karlsfeld (DE); **James V. Kraimer**, Munich (DE); **Thornton K. Lothrop**, Worthington, OH (US); **Rainer B. Teufel**, Worthington, OH (US)

(57) **CLAIM**

The ornamental design for a rear entry pallet truck, as shown and described.

(73) Assignee: **Crown Equipment Corporation**, New Bremen, OH (US)

DESCRIPTION

(**) Term: **14 Years**

FIG. 1 is a perspective view of a rear entry pallet truck as seen from the top, front and left;

(21) Appl. No.: **29/333,700**

FIG. 2 is a perspective view as seen from the top, rear and right thereof;

(22) Filed: **Mar. 13, 2009**

FIG. 3 is a front elevational view thereof;

(51) **LOC (9) Cl.** **12-05**

(52) **U.S. Cl.** **D34/34**

(58) **Field of Classification Search** D34/34;
280/402; 180/89.12, 89.14, 89.17, 89.18,
180/89.19; 414/679, 81.4, 294, 680
See application file for complete search history.

FIG. 4 is a left side elevational view thereof, the right side elevational view being a mirror image;

FIG. 5 is a rear elevational view thereof;

FIG. 6 is a top plan view thereof;

FIG. 7 is a bottom plan view thereof;

FIG. 8 is a view of FIG. 1 with design obscuring broken lines removed;

FIG. 9 is a view of FIG. 2 with design obscuring broken lines removed;

FIG. 10 is a view of FIG. 3 with design obscuring broken lines removed;

FIG. 11 is a view of FIG. 5 with design obscuring broken lines removed;

FIG. 12 is a view of FIG. 6 with design obscuring broken lines removed; and,

FIG. 13 is a view of FIG. 7 with design obscuring broken lines removed.

(56) **References Cited**

U.S. PATENT DOCUMENTS

D237,371 S * 10/1975 Brown D34/37
5,297,645 A * 3/1994 Eckersley et al. 180/68.5

(Continued)

OTHER PUBLICATIONS

Atlet product brochure—available prior to Mar. 13, 2009; 2 pages.
BT product brochure 1—available prior to Mar. 13, 2009; 4 pages.

(Continued)

The broken line showings in the figures are for illustrative purposes only and form no part of the claimed design.

1 Claim, 11 Drawing Sheets

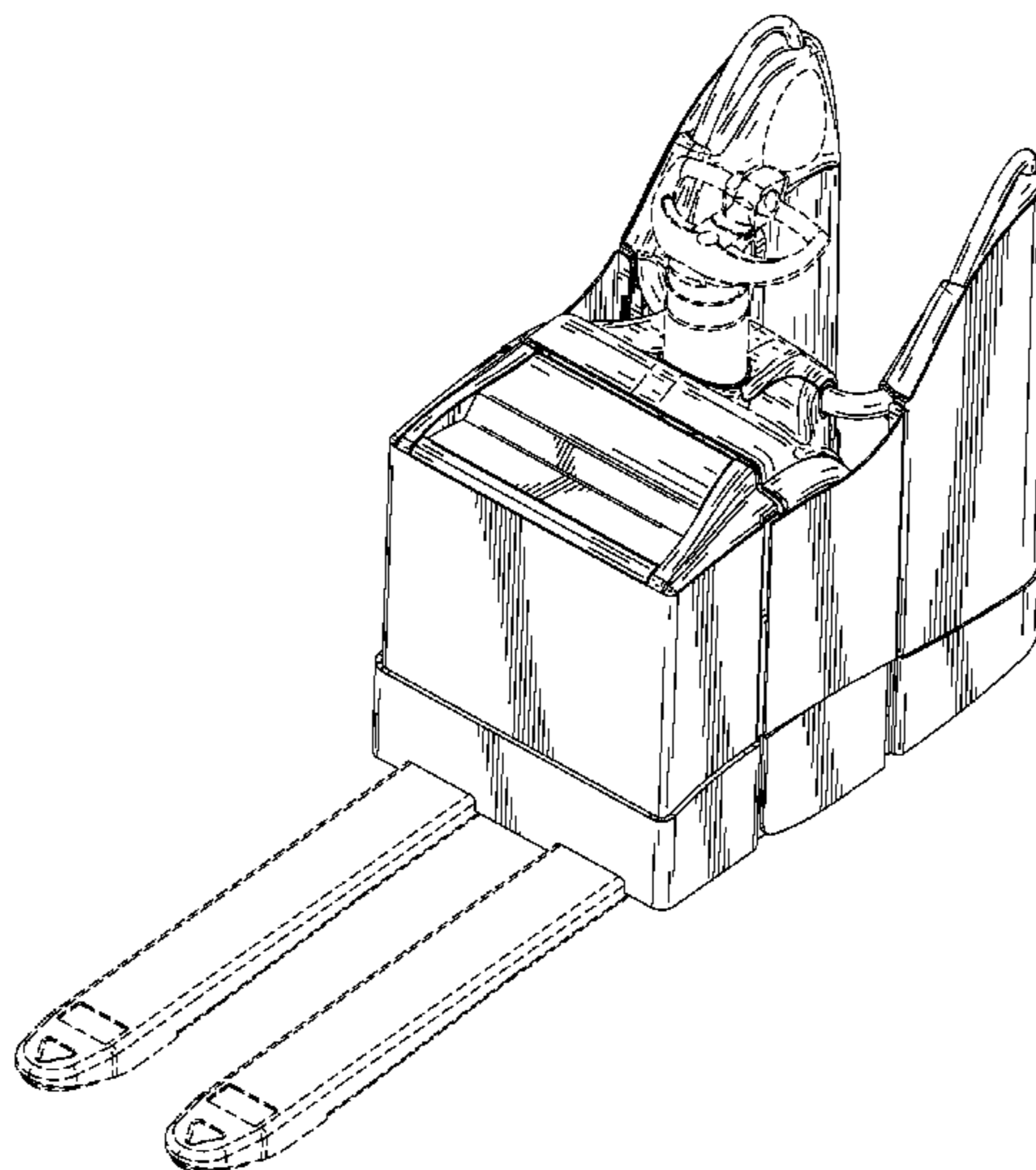

U.S. PATENT DOCUMENTS

D370,761	S	*	6/1996	Stark	D34/34
D373,887	S	*	9/1996	Soederberg	D34/34
D373,888	S	*	9/1996	Soederberg	D34/34
D407,176	S	*	3/1999	Henshaw et al.	D34/34
D407,177	S	*	3/1999	Henshaw et al.	D34/34
6,125,971	A	*	10/2000	Niebuhr et al.	187/231
D537,226	S	*	2/2007	Niebuhr	D34/34
D559,498	S	*	1/2008	Ruppert et al.	D34/34
D562,525	S	*	2/2008	Graf et al.	D34/34
D583,124	S	*	12/2008	Stark	D34/34
D585,623	S	*	1/2009	Quinlan et al.	D34/34
2008/0179141	A1	*	7/2008	Niebuhr	187/222

OTHER PUBLICATIONS

BT product brochure 2—available prior to Mar. 13, 2009; 4 pages.
 BT product brochure 3—available prior to Mar. 13, 2009; 4 pages.
 Photograph 1 of BT truck—available prior to Mar. 13, 2009.
 Photograph 2 of BT truck—available prior to Mar. 13, 2009.
 Photograph 3 of BT truck—available prior to Mar. 13, 2009.
 Photograph 4 of BT truck—available prior to Mar. 13, 2009.
 Photograph 5 of BT truck—available prior to Mar. 13, 2009.
 Photograph 6 of BT truck—available prior to Mar. 13, 2009.
 Photograph 7 of BT truck—available prior to Mar. 13, 2009.
 Photograph 8 of BT truck—available prior to Mar. 13, 2009.
 Hyster product brochure—available prior to Mar. 13, 2009; 4 pages.
 Photograph 1 of Yale truck—available prior to Mar. 13, 2009.
 Photograph 2 of Yale truck—available prior to Mar. 13, 2009.
 Photograph 3 of Yale truck—available prior to Mar. 13, 2009.
 Photograph 4 of Yale truck—available prior to Mar. 13, 2009.
 Photograph 5 of Yale truck—available prior to Mar. 13, 2009.
 Jungheinrich product brochure 1—available prior to Mar. 13, 2009; 4 pages.
 Jungheinrich product brochure 2—available prior to Mar. 13, 2009; 4 pages.
 Jungheinrich product brochure 3—available prior to Mar. 13, 2009; 4 pages.
 Jungheinrich product brochure 4—available prior to Mar. 13, 2009; 1 page.
 Photograph 1 of Jungheinrich truck—available prior to Mar. 13, 2009.
 Photograph 2 of Jungheinrich truck—available prior to Mar. 13, 2009.
 Photograph 3 of Jungheinrich truck—available prior to Mar. 13, 2009.
 Photograph 4 of Jungheinrich truck—available prior to Mar. 13, 2009.
 Linde product brochure 1—available prior to Mar. 13, 2009; 2 pages.
 Linde product brochure 2—available prior to Mar. 13, 2009; 6 pages.
 Photograph 1 of Linde truck—available prior to Mar. 13, 2009.
 Photograph 2 of Linde truck—available prior to Mar. 13, 2009.
 Photograph 1 of Loc-Manitou truck—available prior to Mar. 13, 2009.
 Photograph 2 of Loc-Manitou truck—available prior to Mar. 13, 2009.
 Photograph 3 of Loc-Manitou truck—available prior to Mar. 13, 2009.
 Photograph 4 of Loc-Manitou truck—available prior to Mar. 13, 2009.

Photograph 5 of Loc-Manitou truck—available prior to Mar. 13, 2009.
 Photograph 6 of Loc-Manitou truck—available prior to Mar. 13, 2009.
 Photograph 7 of Loc-Manitou truck—available prior to Mar. 13, 2009.
 Photograph 8 of Loc-Manitou truck—available prior to Mar. 13, 2009.
 Photograph 1 of various brand truck—available prior to Mar. 13, 2009.
 Photograph 2 of various brand truck—available prior to Mar. 13, 2009.
 Photograph 3 of various brand truck—available prior to Mar. 13, 2009.
 Photograph 4 of various brand truck—available prior to Mar. 13, 2009.
 Photograph 5 of various brand truck—available prior to Mar. 13, 2009.
 Photograph 6 of various brand truck—available prior to Mar. 13, 2009.
 Photograph 7 of various brand truck—available prior to Mar. 13, 2009.
 Photograph 8 of various brand truck—available prior to Mar. 13, 2009.
 Photograph 9 of various brand truck—available prior to Mar. 13, 2009.
 Photograph 10 of various brand truck—available prior to Mar. 13, 2009.
 Photograph 11 of various brand truck—available prior to Mar. 13, 2009.
 Photograph 12 of various brand truck—available prior to Mar. 13, 2009.
 Photograph 13 of various brand truck—available prior to Mar. 13, 2009.
 Photograph 14 of various brand truck—available prior to Mar. 13, 2009.
 Photograph 15 of various brand truck—available prior to Mar. 13, 2009.
 Photograph 16 of various brand truck—available prior to Mar. 13, 2009.
 Photograph 17 of various brand truck—available prior to Mar. 13, 2009.
 Photograph 18 of various brand truck—available prior to Mar. 13, 2009.
 Photograph 19 of various brand truck—available prior to Mar. 13, 2009.
 Photograph 20 of various brand truck—available prior to Mar. 13, 2009.
 Photograph 21 of various brand truck—available prior to Mar. 13, 2009.
 OM Carrelli Elevatori product brochure—available prior to Mar. 13, 2009; 4 pages.
 Rocla product brochure—available prior to Mar. 13, 2009; 9 pages.
 Still product brochure 1—available prior to Mar. 13, 2009; 8 pages.
 Still product brochure 2—available prior to Mar. 13, 2009; 8 pages.
 Photograph 1 of Still truck—available prior to Mar. 13, 2009.
 Photograph 2 of Still truck—available prior to Mar. 13, 2009.
 Photograph 3 of Still truck—available prior to Mar. 13, 2009.
 Crown product brochure—WP 2300 Series—available prior to Mar. 13, 2009; 8 pages.
 * cited by examiner

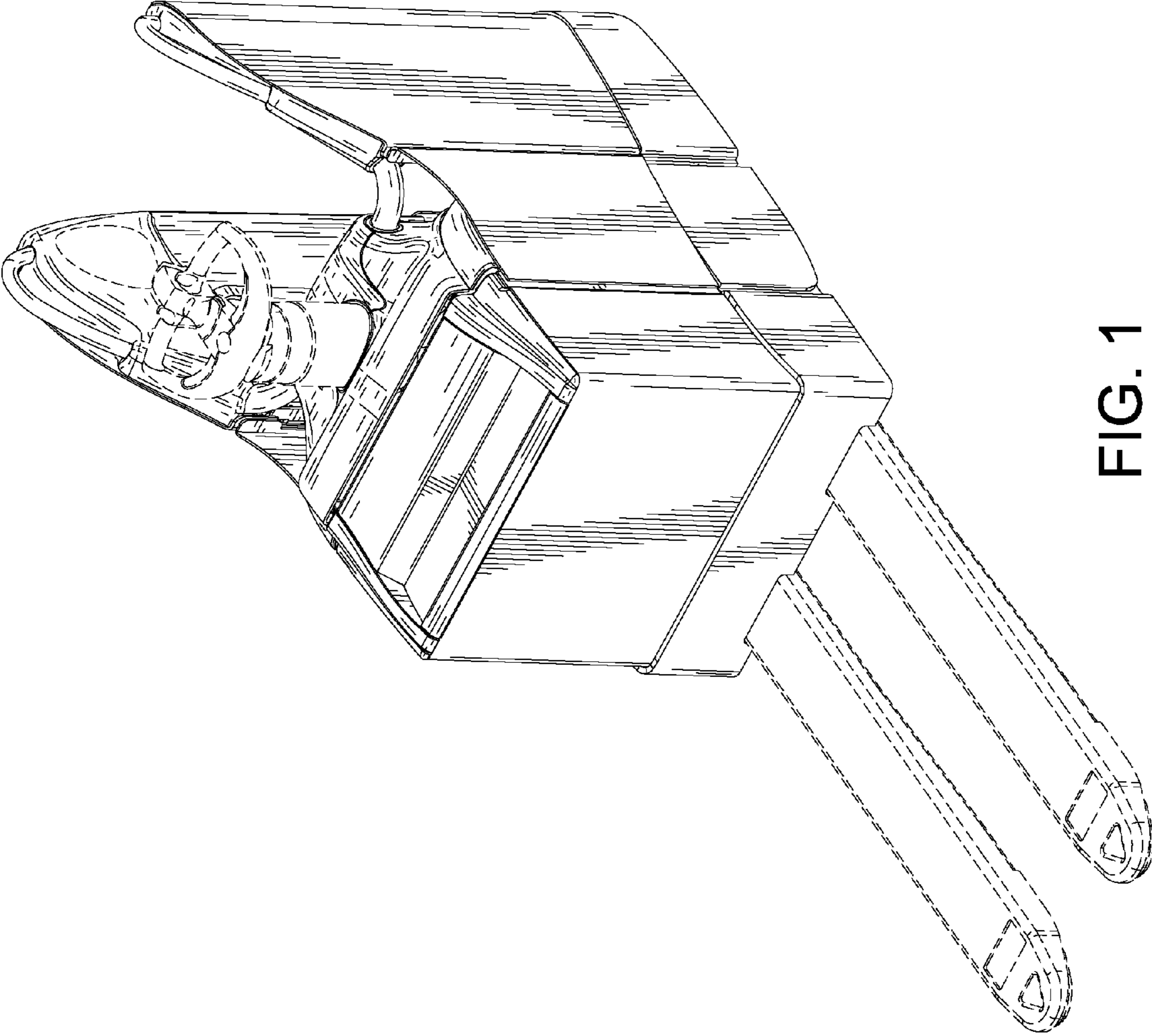

FIG. 1

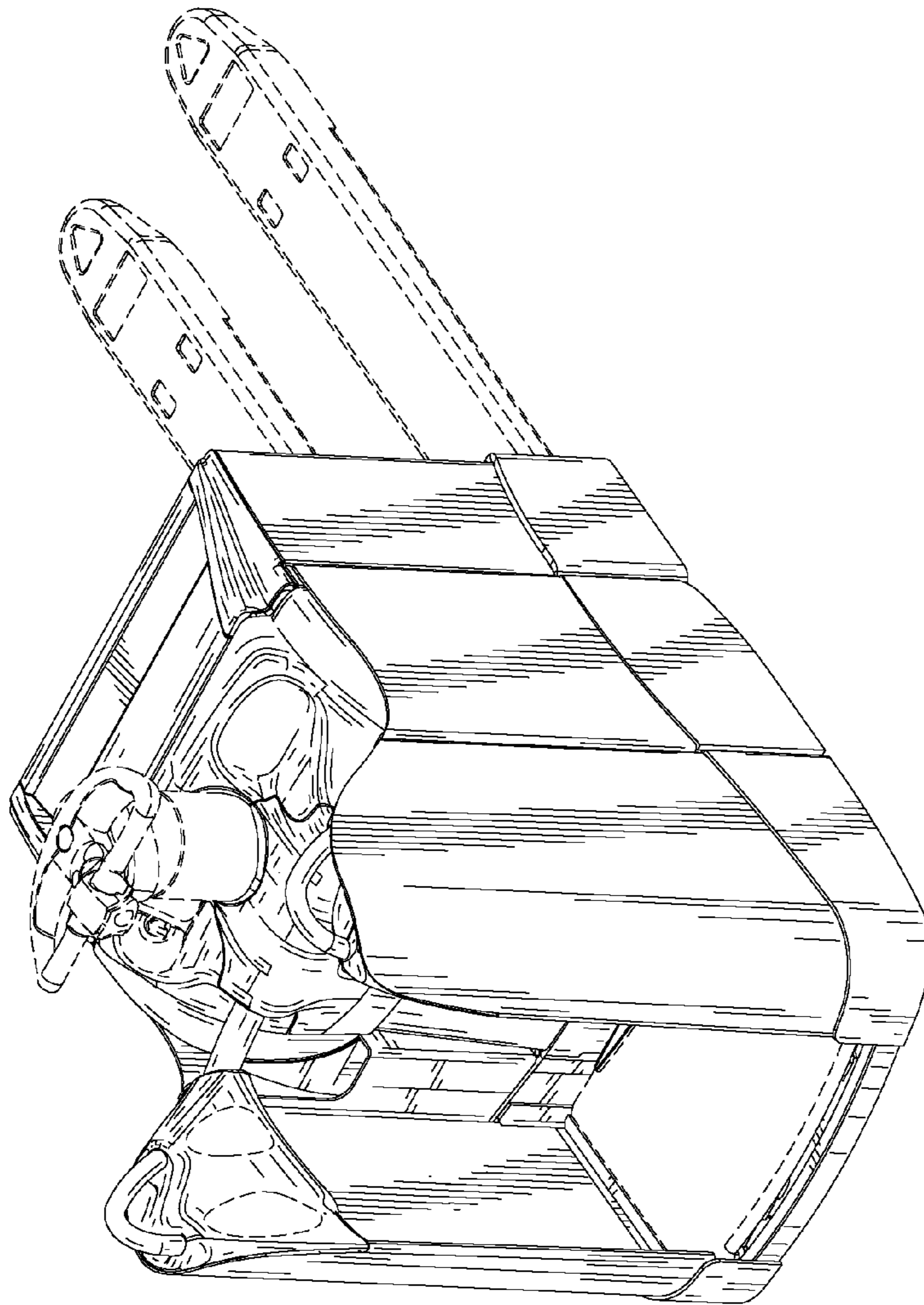

FIG. 2

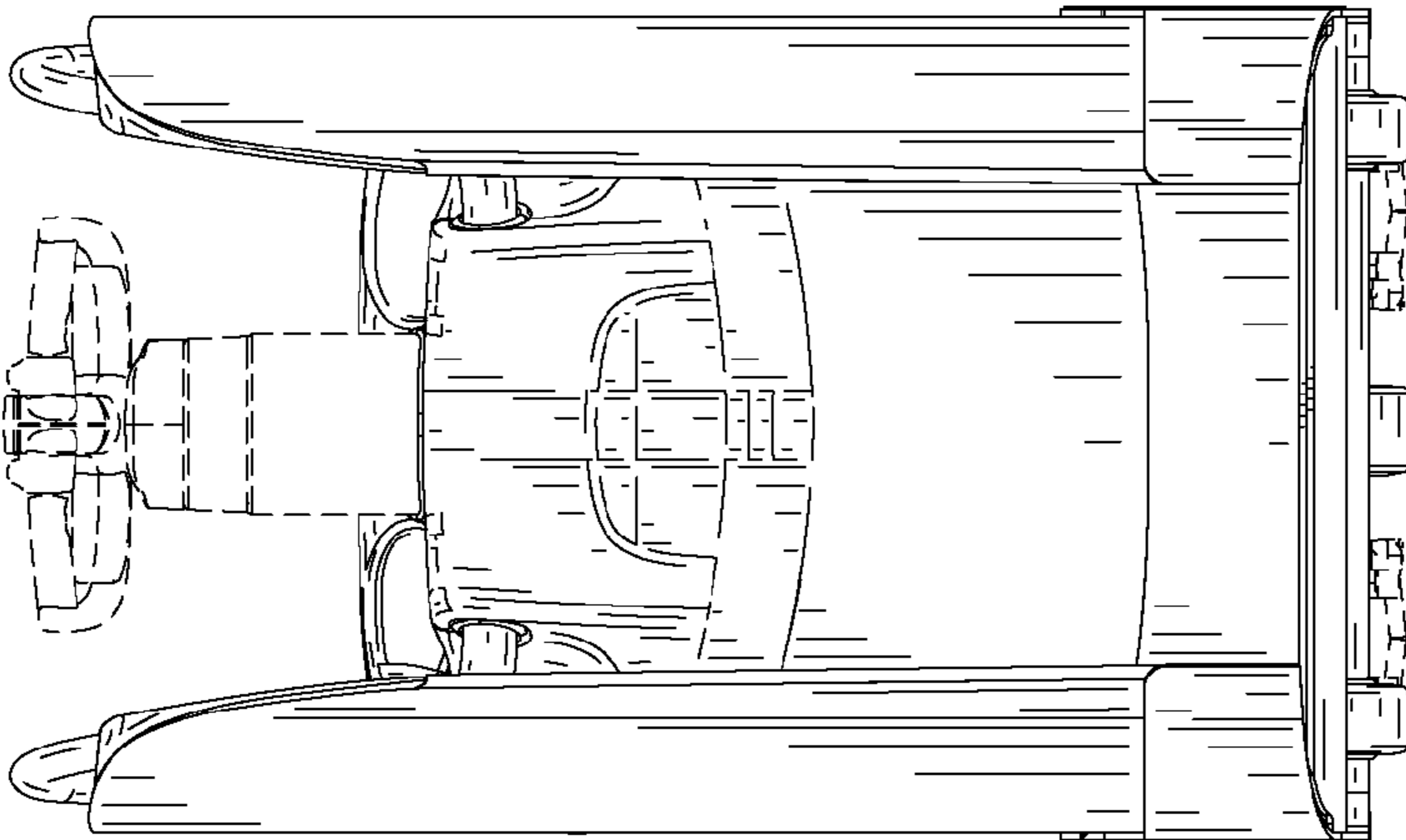

FIG. 5

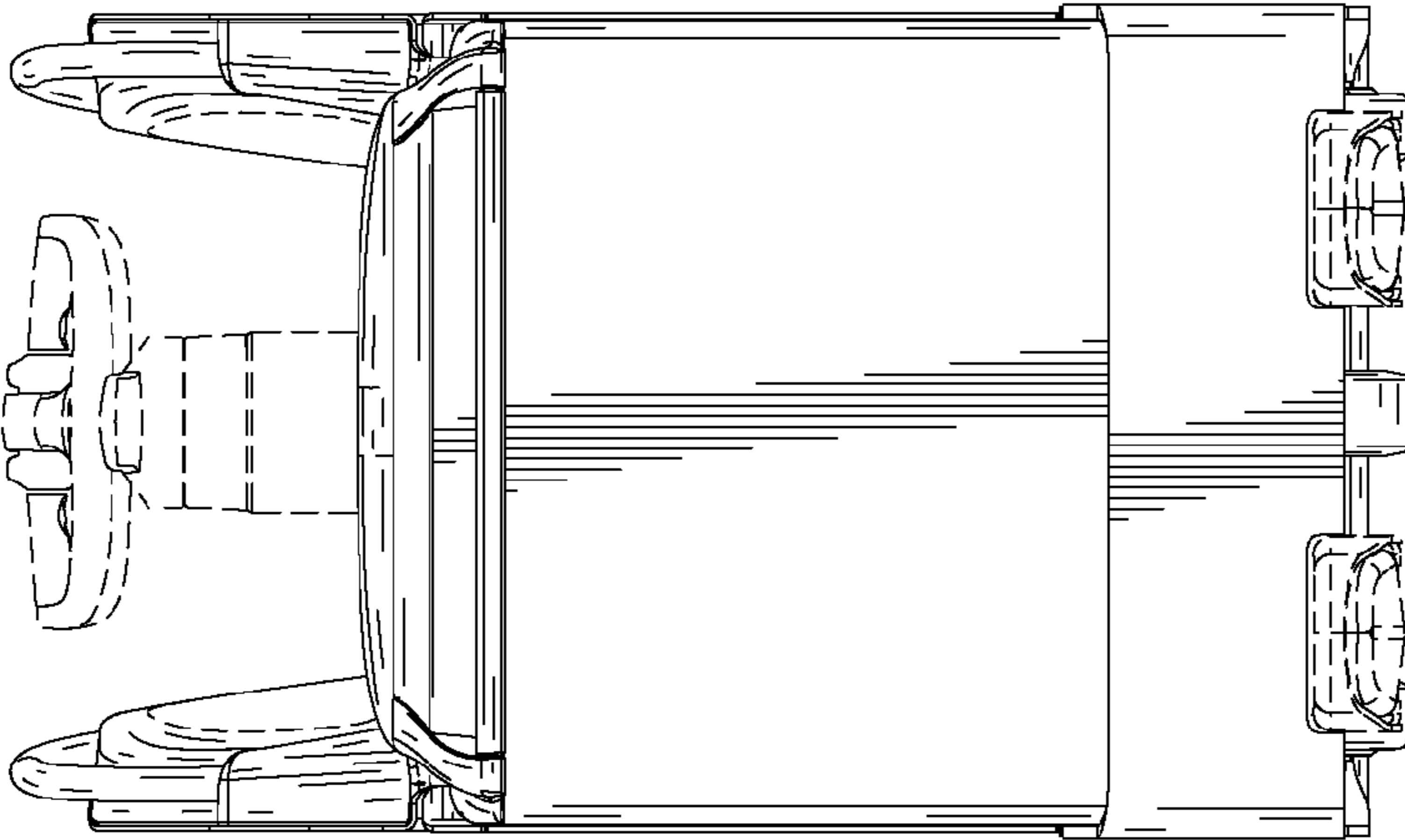

FIG. 3

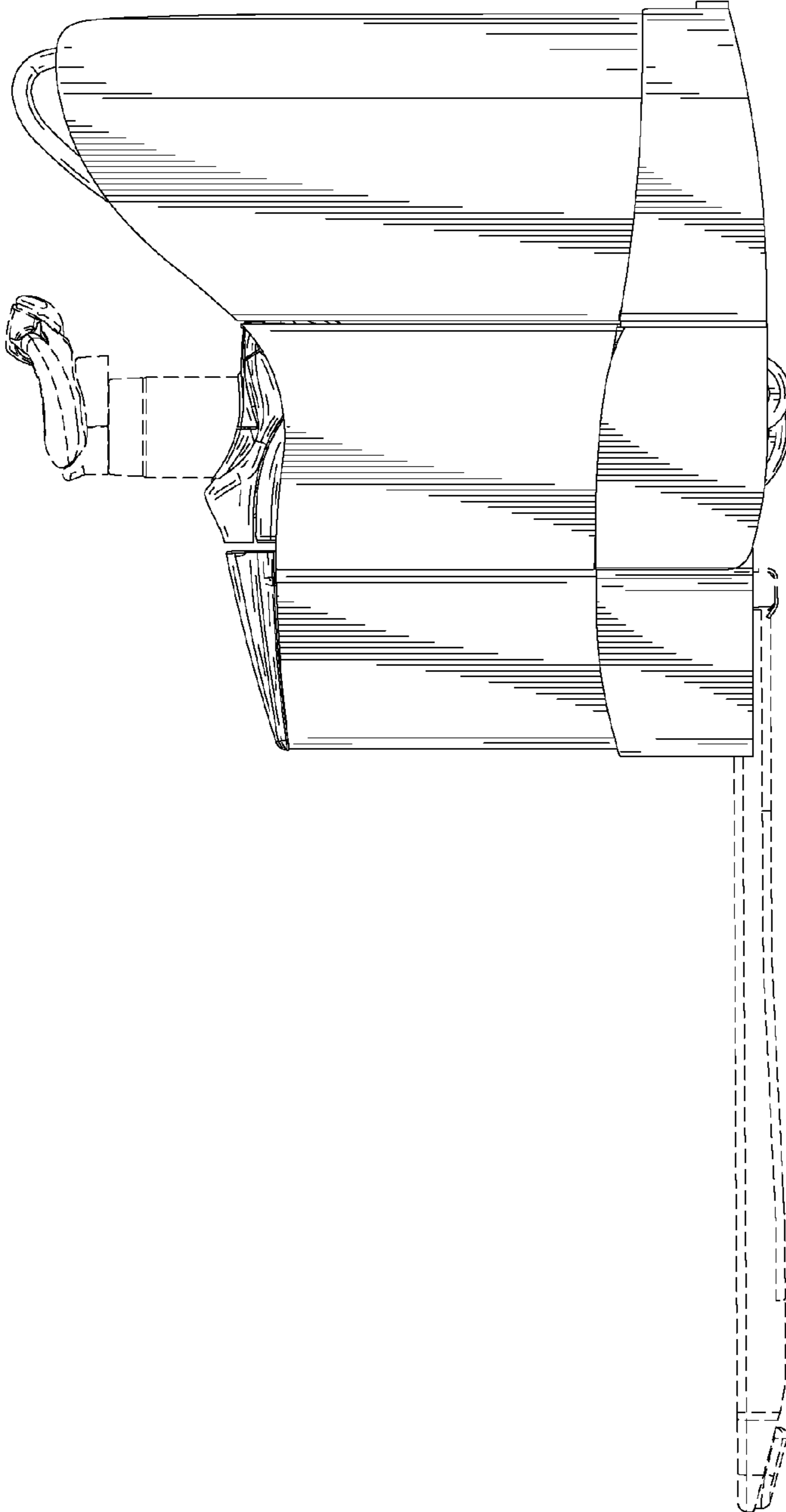

FIG. 4

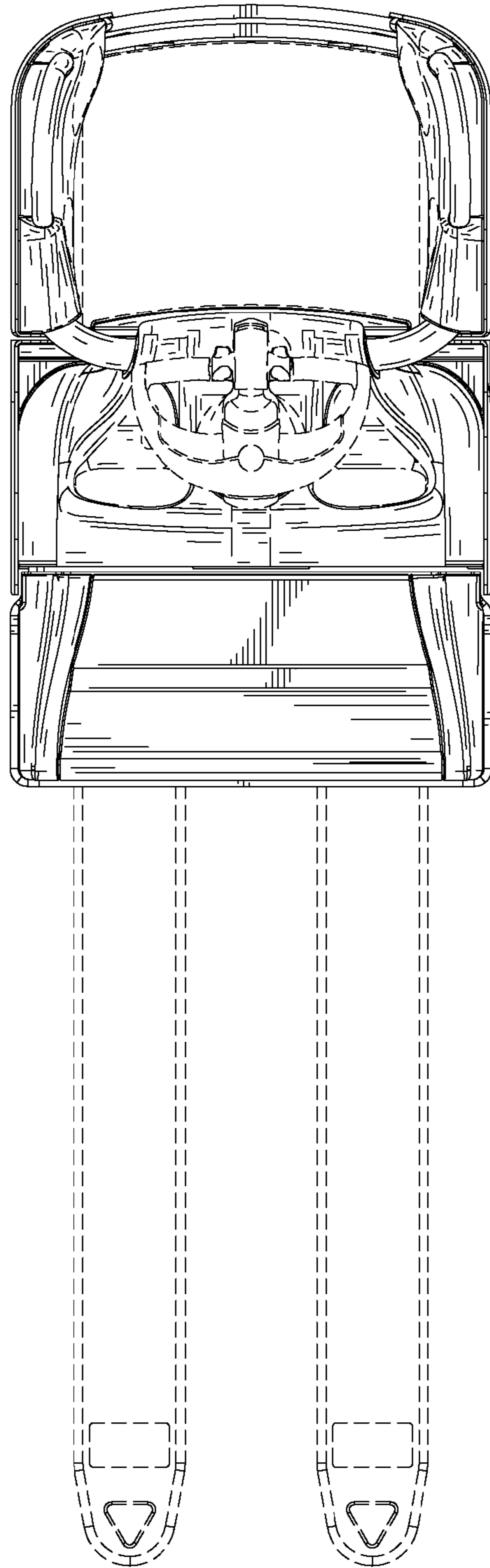

FIG. 6

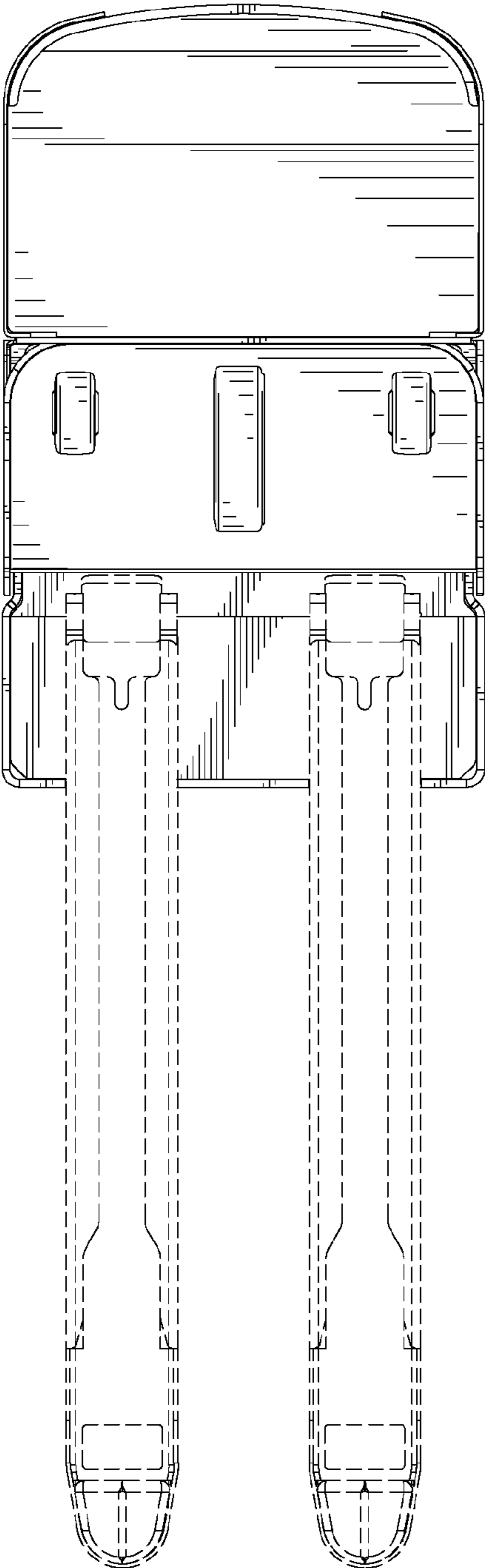

FIG. 7

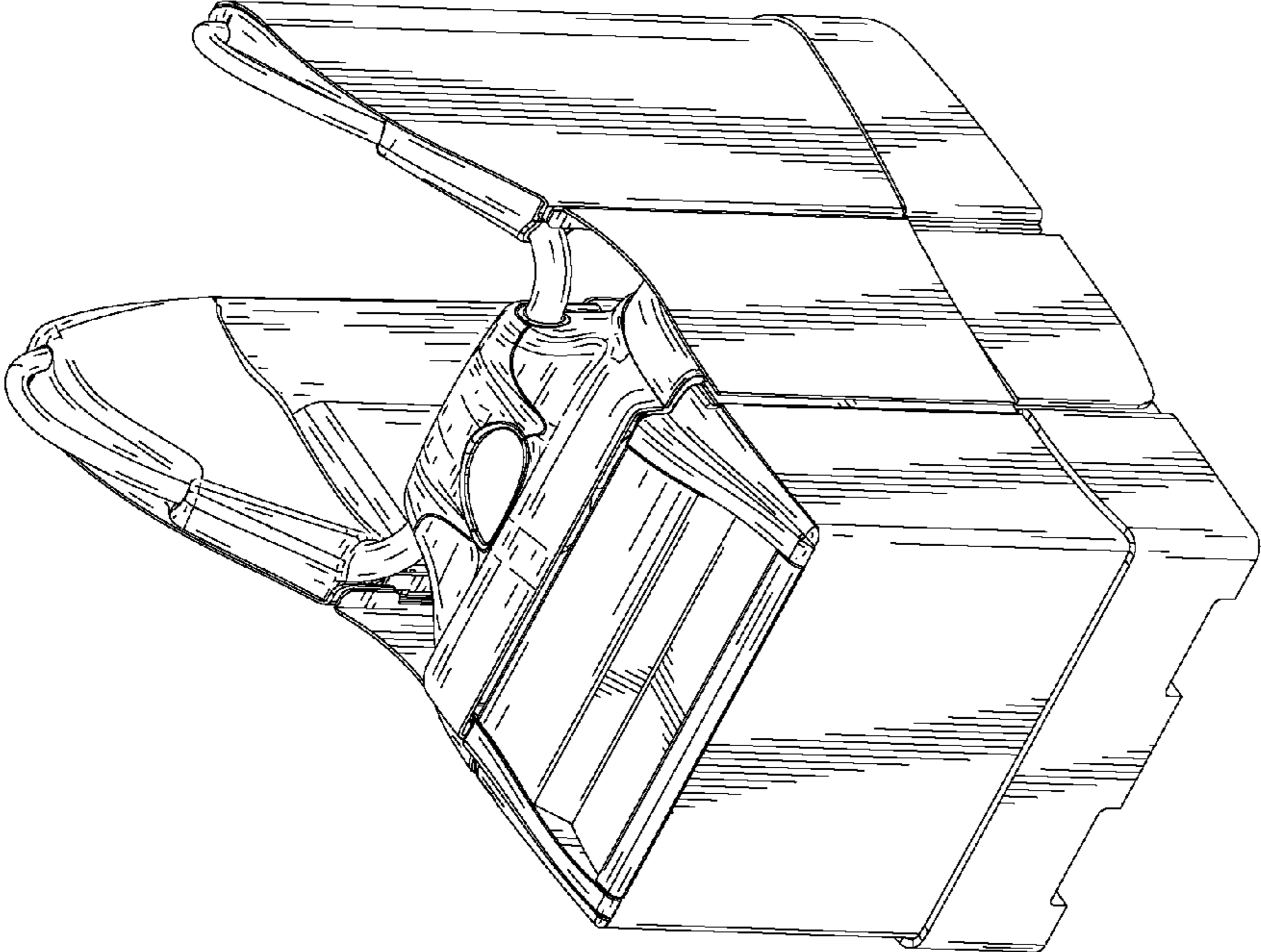

FIG. 8

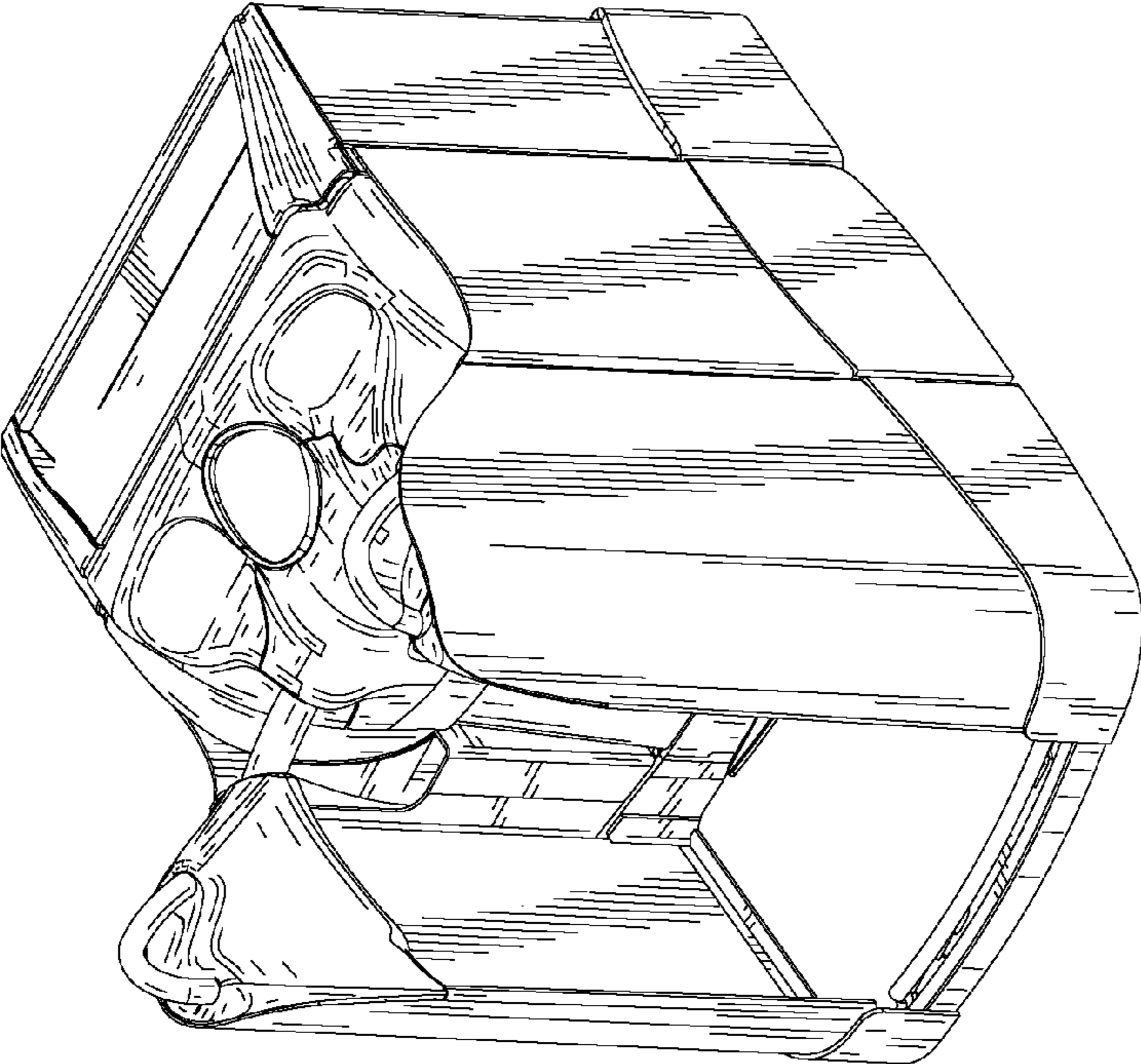

FIG. 9

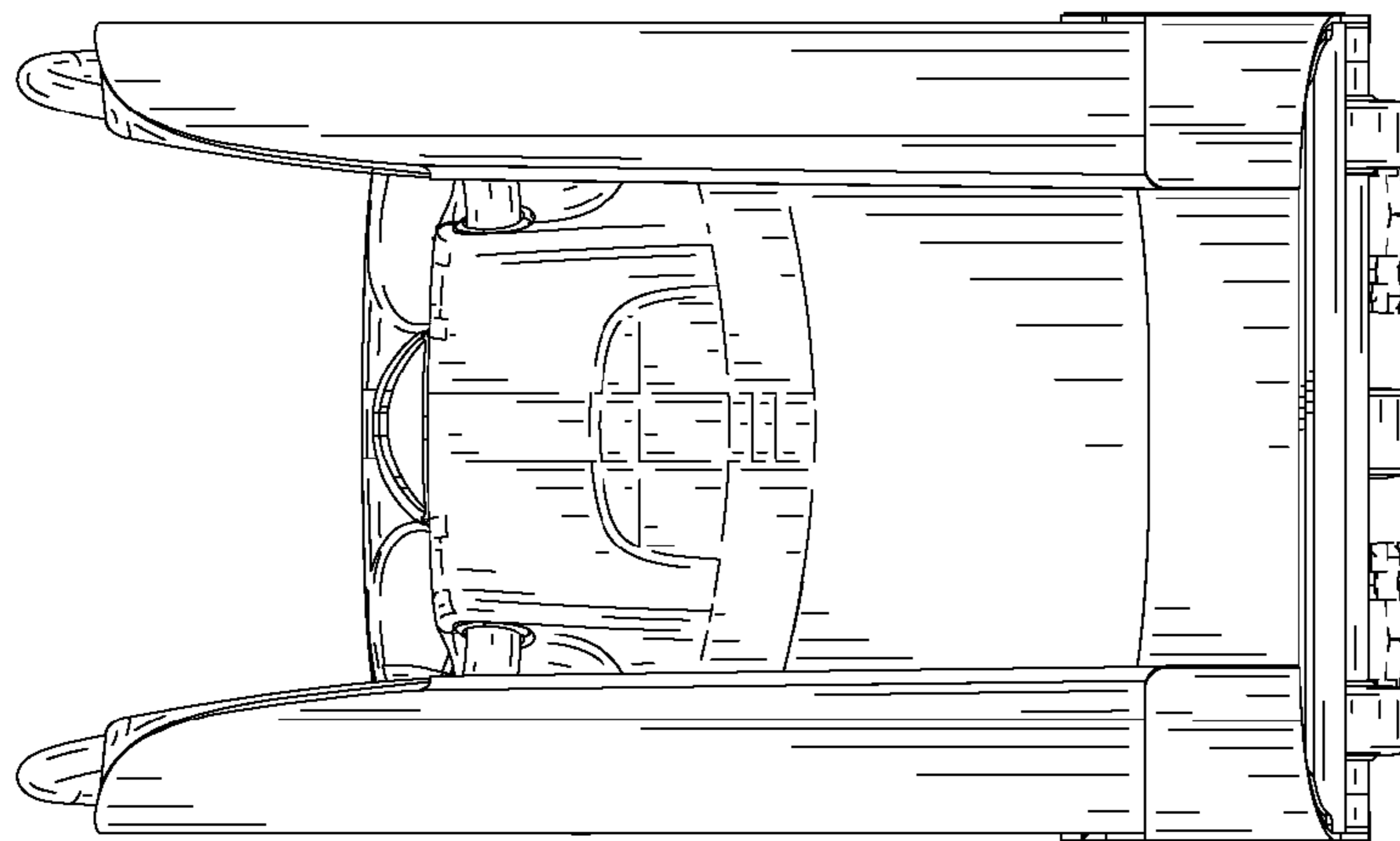

FIG. 11

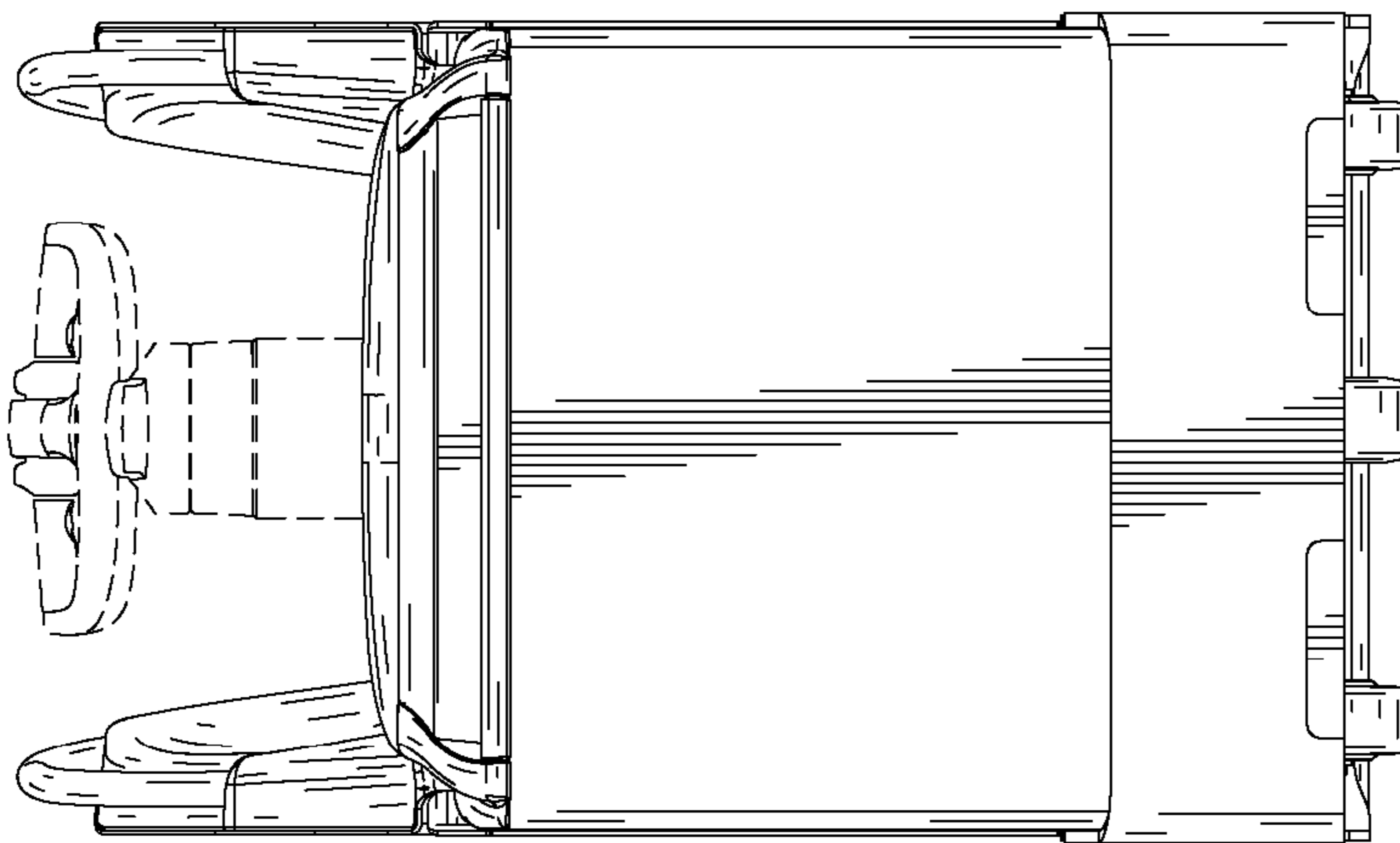

FIG. 10

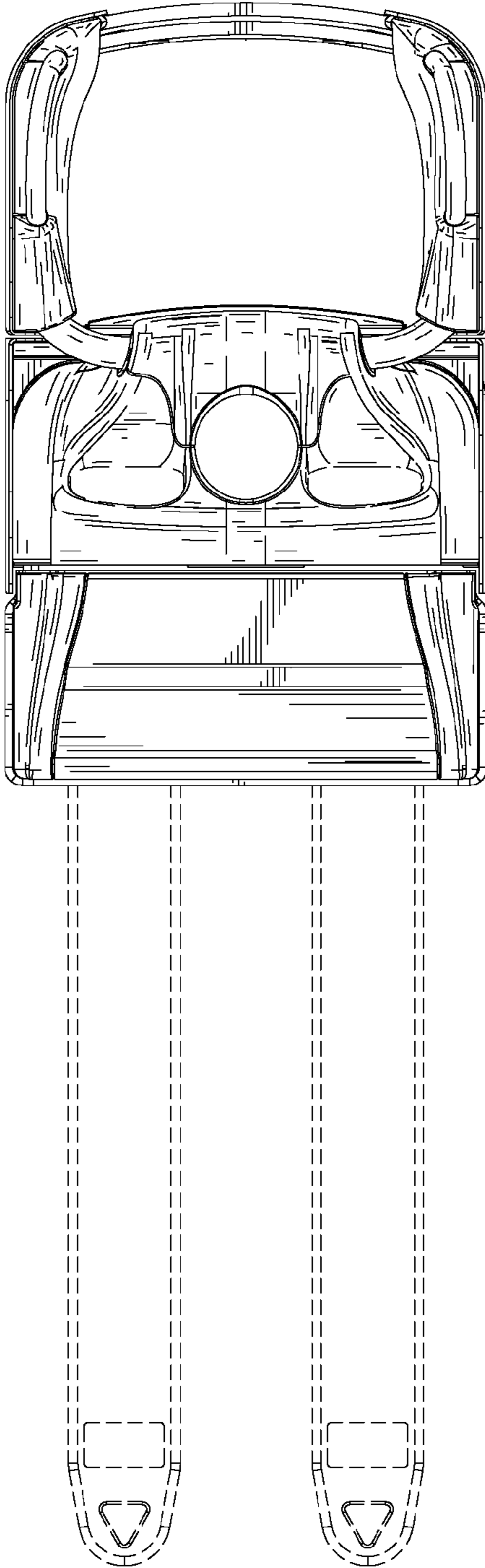

FIG. 12

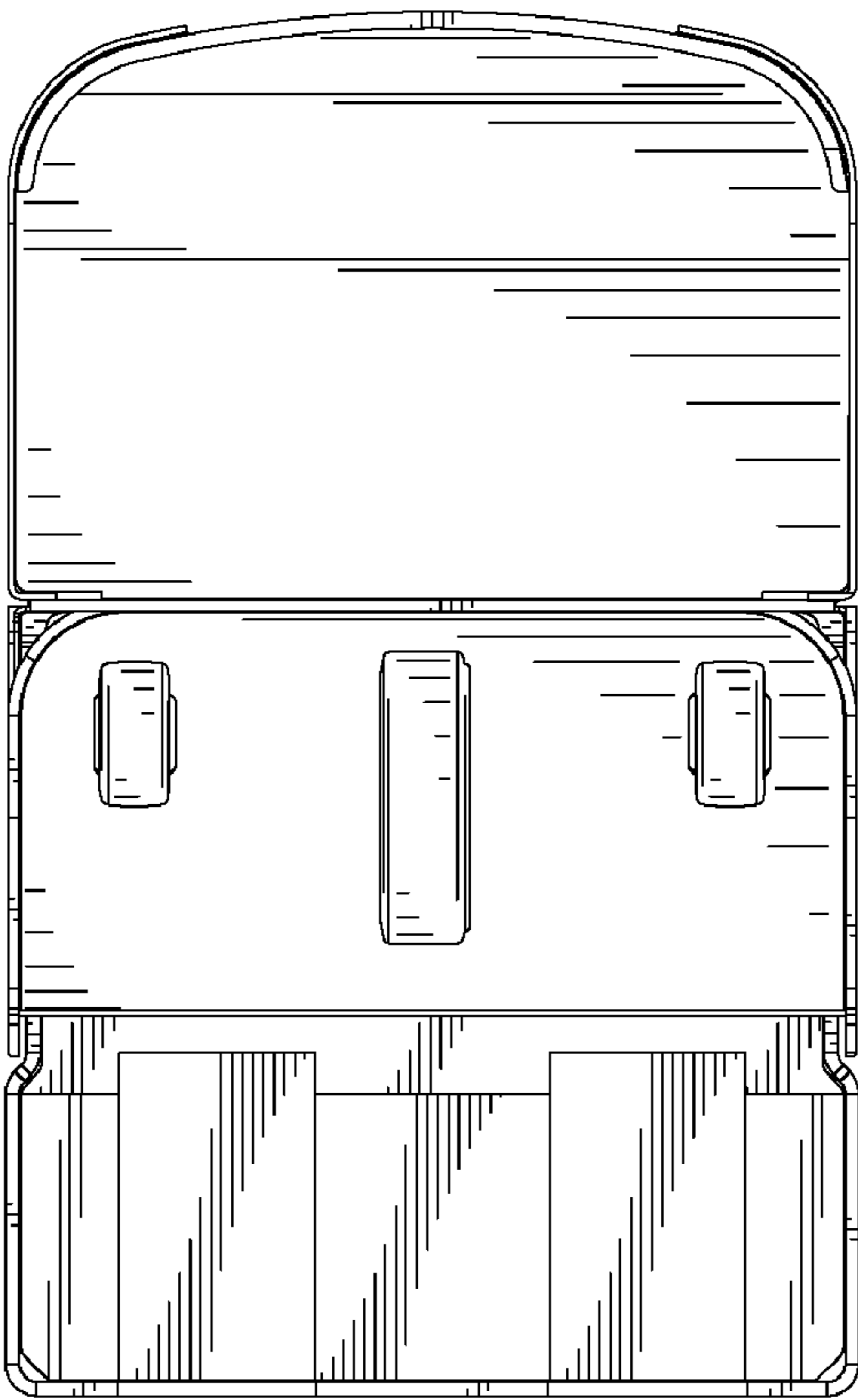

FIG. 13