



US00D608518S

(12) **United States Design Patent**  
**Luebke**

(10) **Patent No.:** **US D608,518 S**  
(45) **Date of Patent:** **\*\* Jan. 19, 2010**

(54) **ENVIRONMENTALLY FRIENDLY SHOPPING CART**

(76) Inventor: **Michael L. Luebke**, N4277 Maple Dr.,  
Iron Ridge, WI (US) 53035

(\*\*) Term: **14 Years**

(21) Appl. No.: **29/338,639**

(22) Filed: **Jun. 16, 2009**

(51) **LOC (9) Cl.** ..... **12-02**

(52) **U.S. Cl.** ..... **D34/21**

(58) **Field of Classification Search** ..... D34/12-27;  
280/641, 640, 43.17, 47.34, 33.991, 33.992,  
280/33.993

See application file for complete search history.

(56) **References Cited**

**U.S. PATENT DOCUMENTS**

4,560,096	A *	12/1985	Lucas et al.	.....	224/411
4,576,388	A *	3/1986	Pope	.....	280/33.995
5,046,748	A *	9/1991	Oat-Judge	.....	280/47.34
D325,364	S *	4/1992	Stilley	.....	D12/129
5,649,718	A *	7/1997	Groglio	.....	280/641
5,918,798	A *	7/1999	Frahm	.....	229/117.07
6,070,899	A *	6/2000	Gines	.....	280/651
6,328,329	B1 *	12/2001	Smith	.....	280/639
D506,060	S *	6/2005	Achilles	.....	D3/233
7,306,244	B2 *	12/2007	Roseman et al.	.....	280/33.991
7,398,977	B2 *	7/2008	Short	.....	280/33.992
2002/0135145	A1 *	9/2002	Saccani	.....	280/33.991
2003/0197339	A1 *	10/2003	D'Angelo	.....	280/33.991
2006/0001225	A1 *	1/2006	Gurley et al.	.....	280/33.992

**FOREIGN PATENT DOCUMENTS**

GB 2116490 A \* 3/1983

\* cited by examiner

*Primary Examiner*—Cynthia E Ramirez  
(74) *Attorney, Agent, or Firm*—Donald J. Ersler

(57) **CLAIM**

The ornamental design for an environmentally friendly shopping cart, as shown and described.

**DESCRIPTION**

FIG. 1 is a perspective view of an environmentally friendly shopping cart incorporating my new design;

FIG. 2 is a right side view thereof without the two bags therein;

FIG. 3 is a top plan view thereof without the two bags therein;

FIG. 4 is a bottom plan view thereof without the two bags therein;

FIG. 5 is a front elevation view thereof without the two bags therein;

FIG. 6 is a rear elevation view thereof without the two bags therein;

FIG. 7 is a perspective view of one of the two bags removed from the cart; only one of the bags shown for convenience or illustration as the bags are identical;

FIG. 8 is a right side view of the bag;

FIG. 9 is a front elevation view of the bag;

FIG. 10 is a top plan view of the bag; and,

FIG. 11 is a bottom plan view of the bag.

The cart is shown without the bags in FIGS. 2 through 6 for convenience of illustration.

**1 Claim, 5 Drawing Sheets**

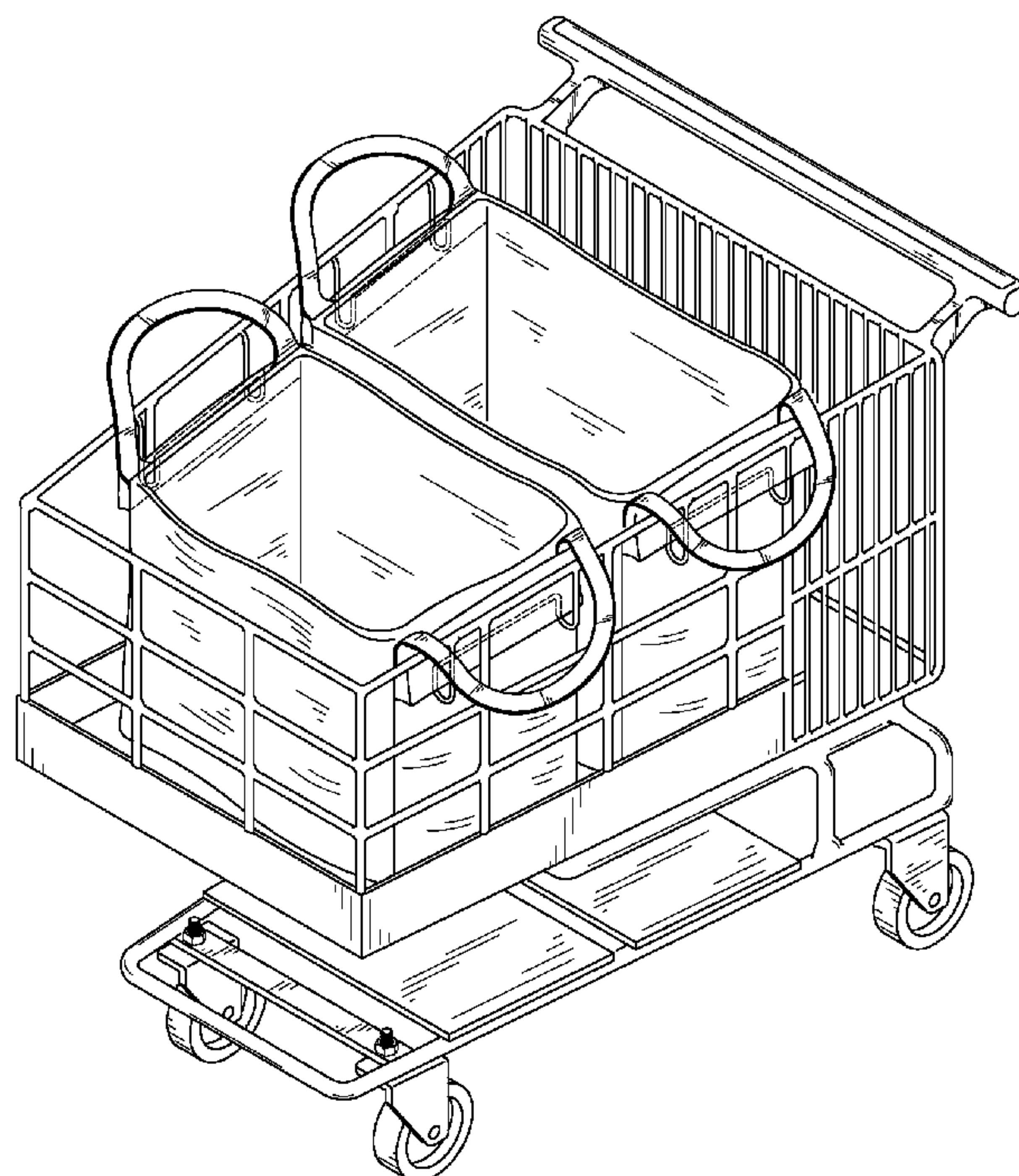

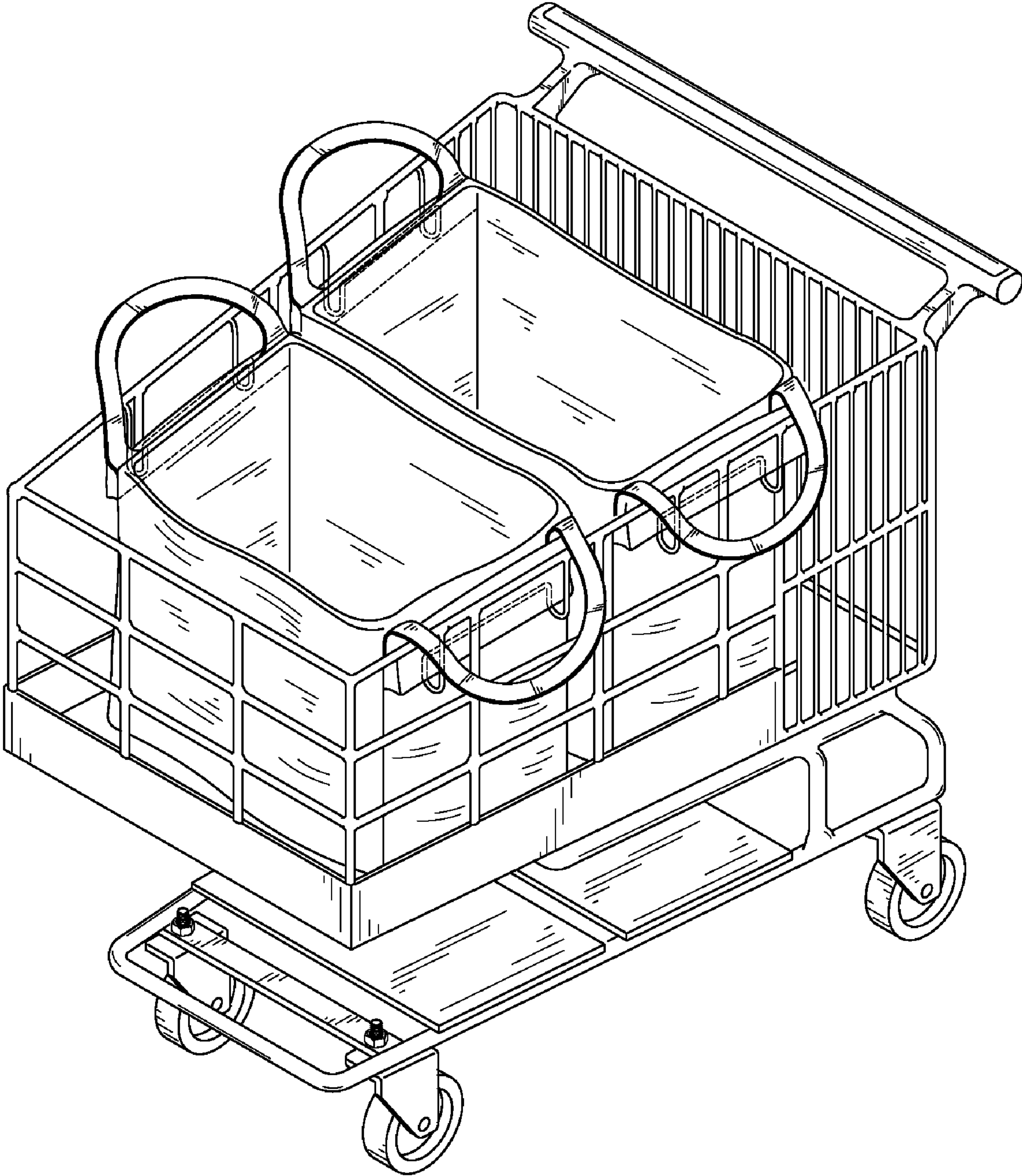

FIG. 1

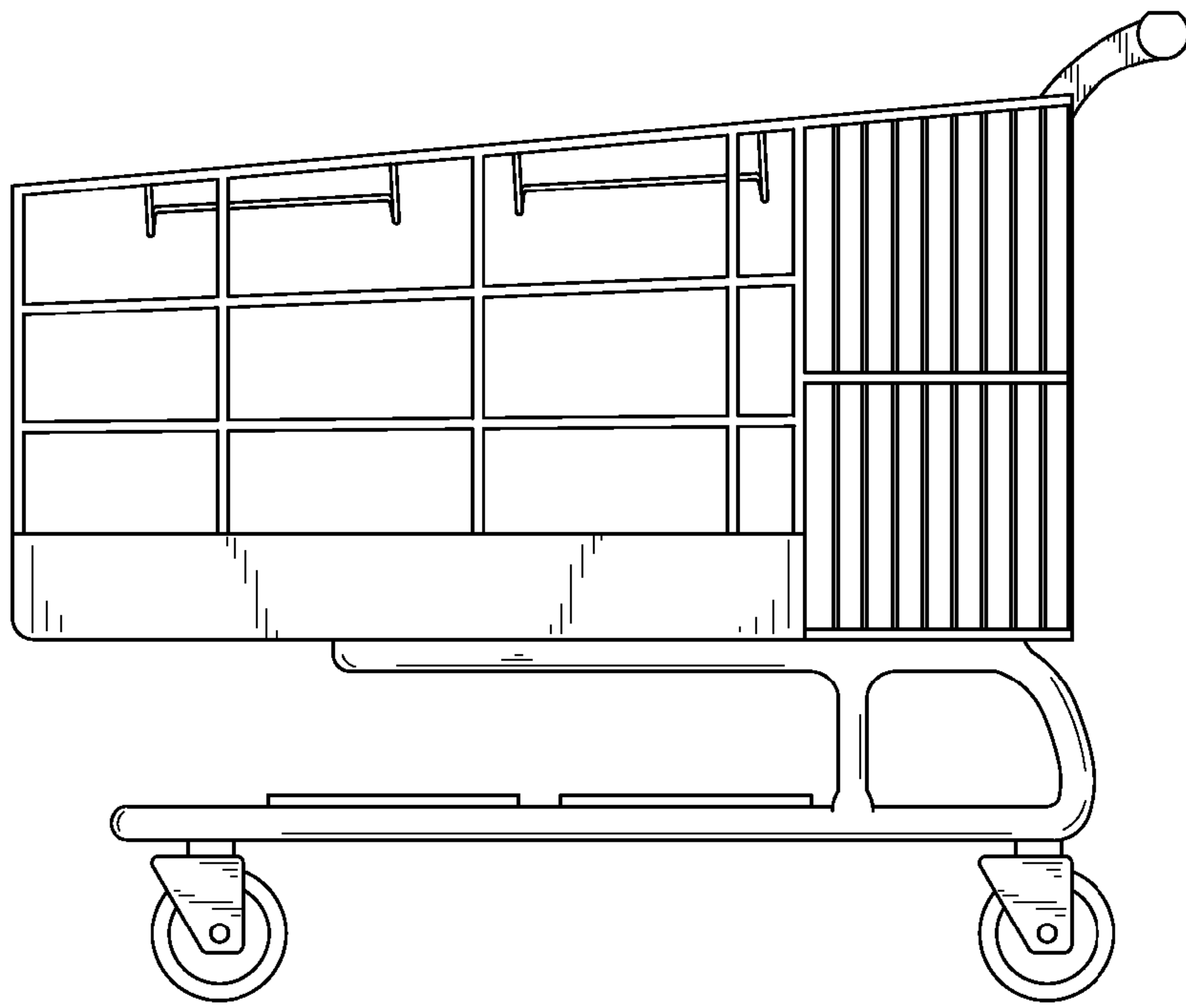

FIG. 2

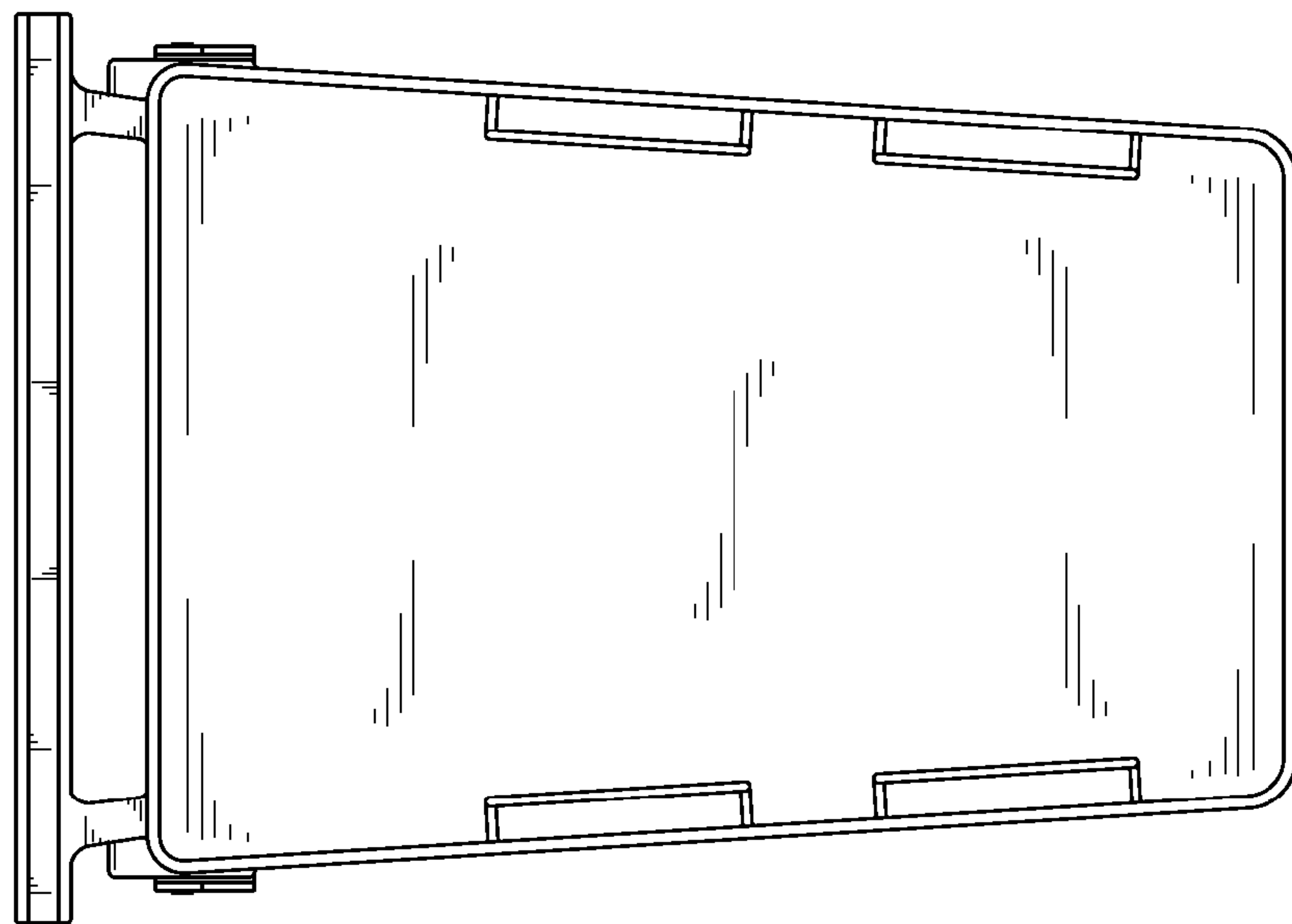

FIG. 3

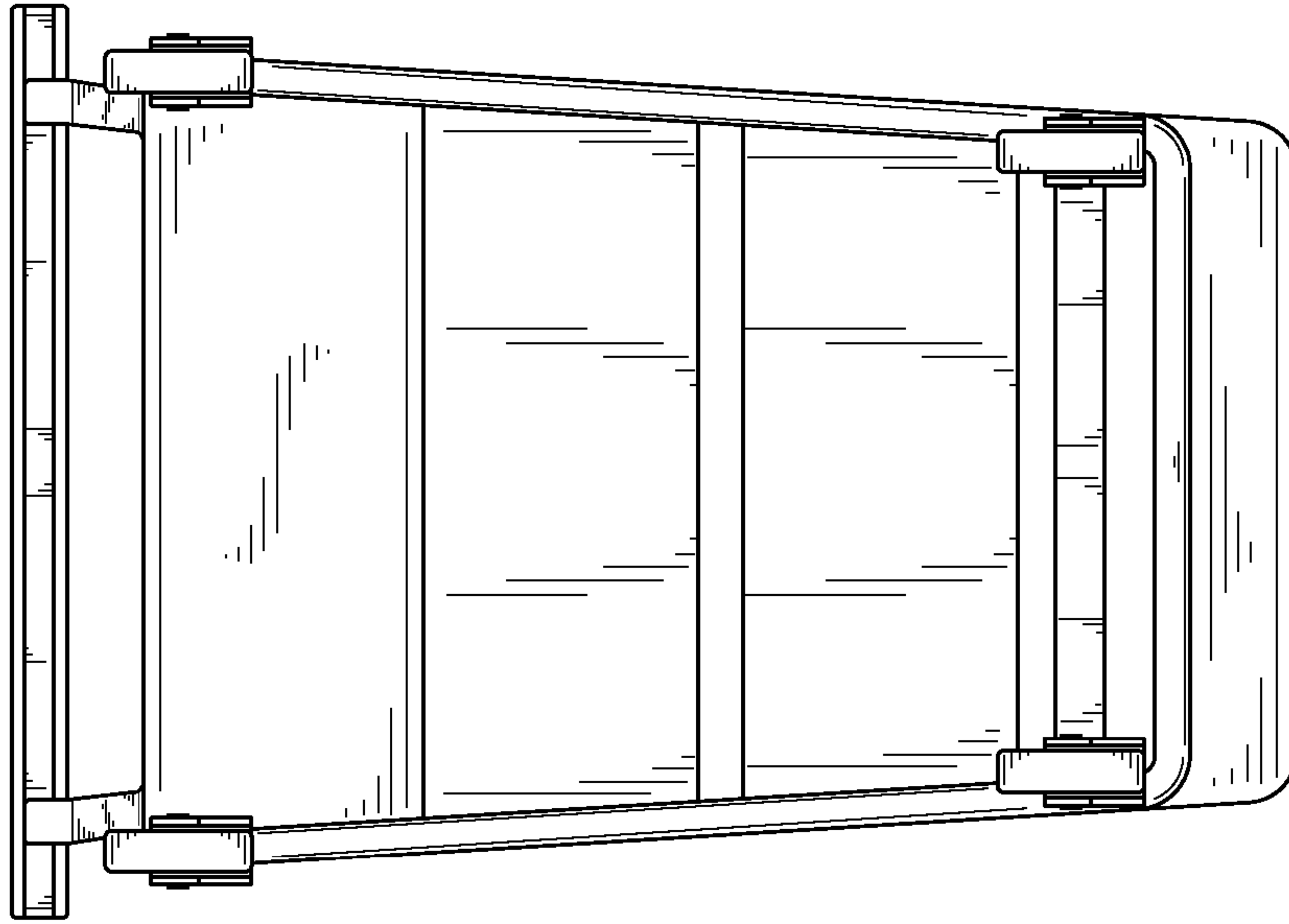

FIG. 4

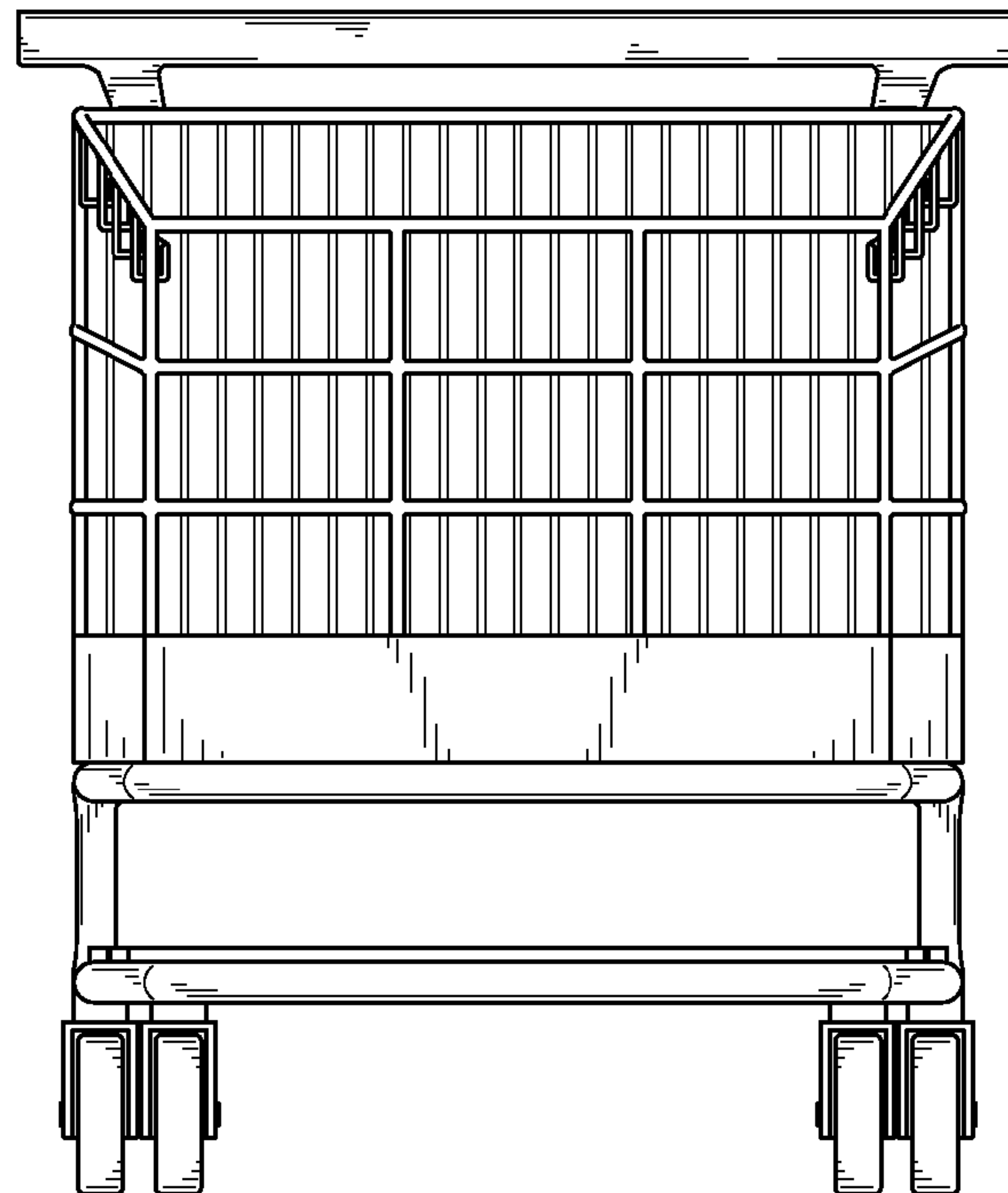

FIG. 5



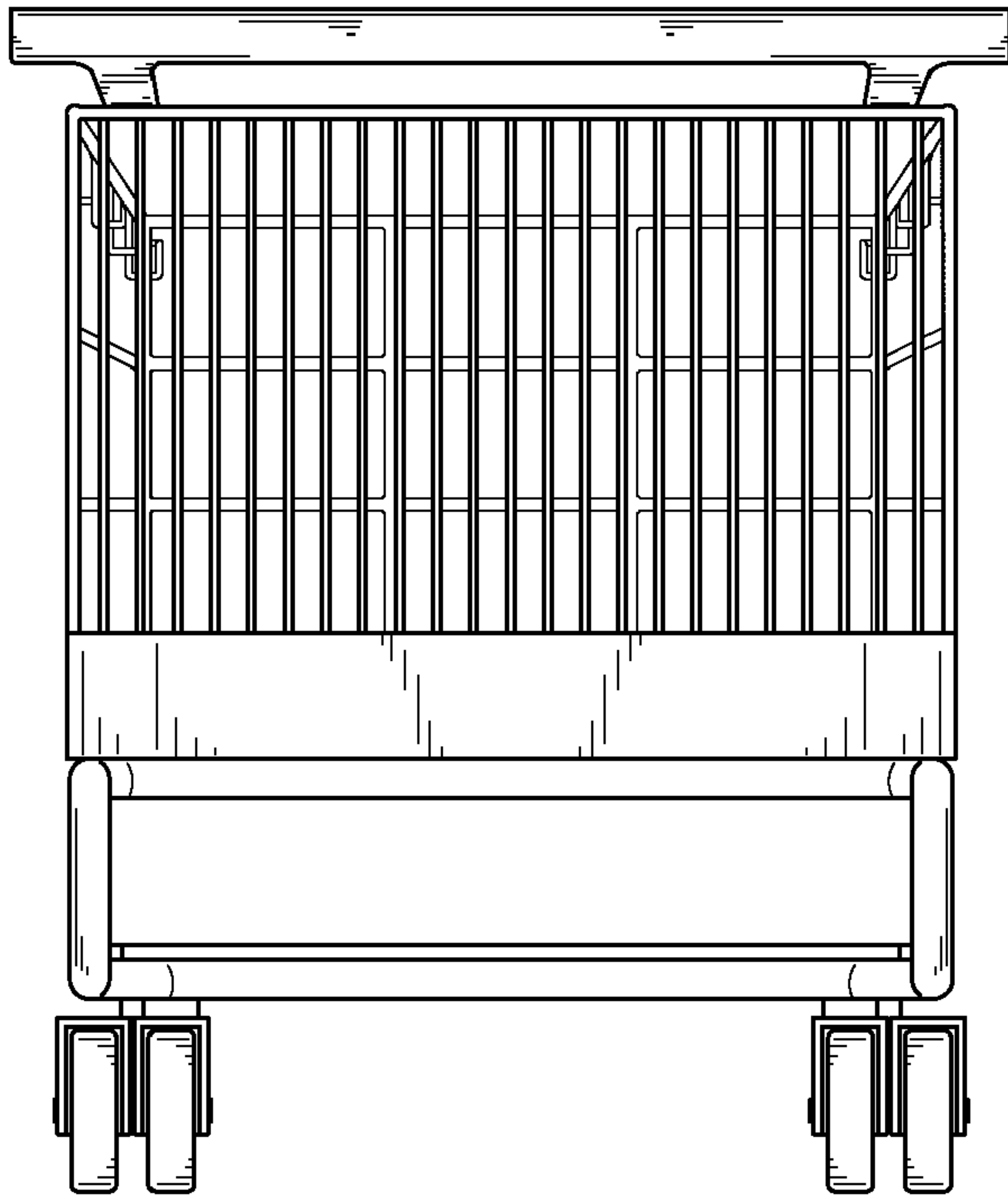

FIG. 6

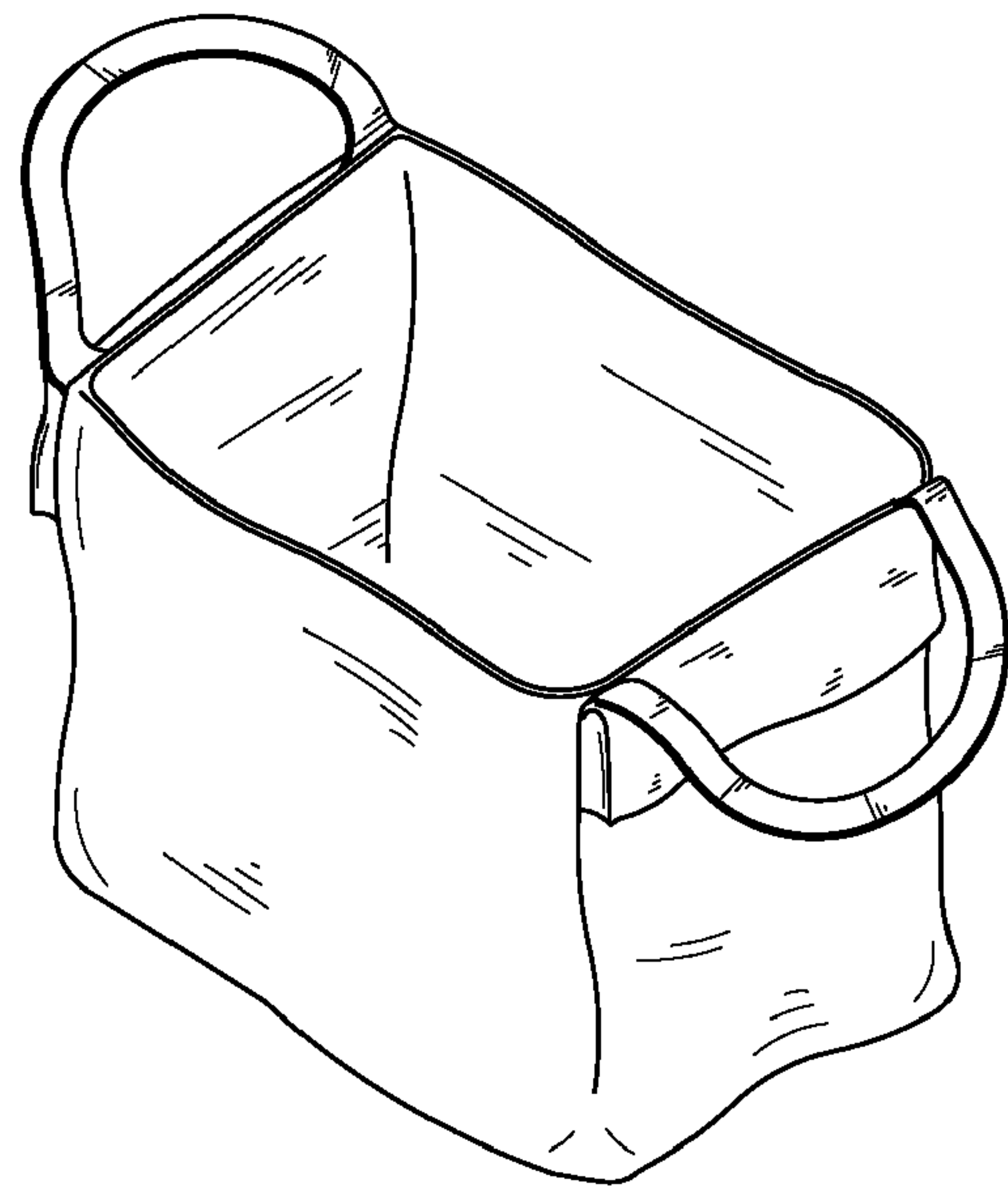

FIG. 7

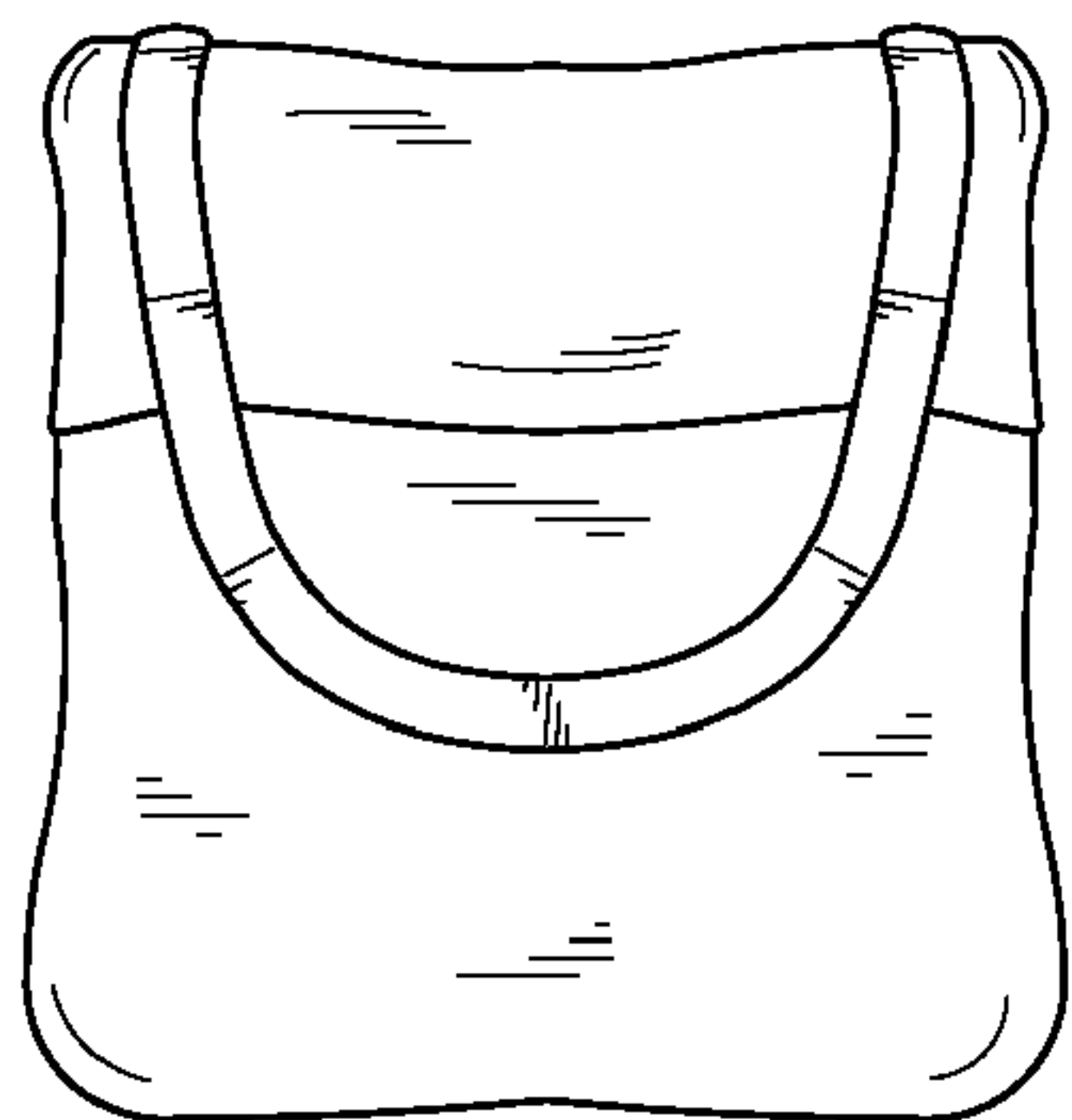

FIG. 8

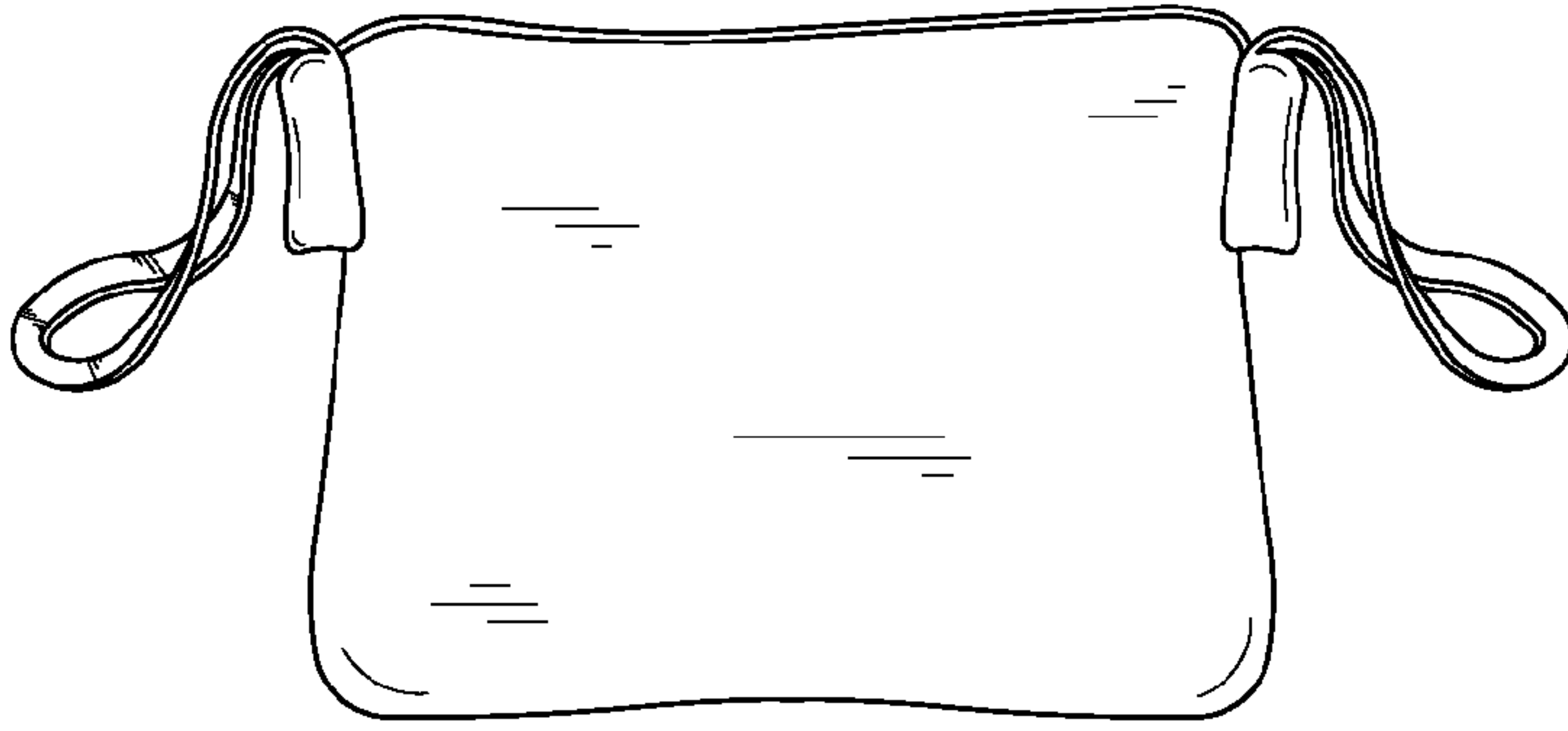

FIG. 9

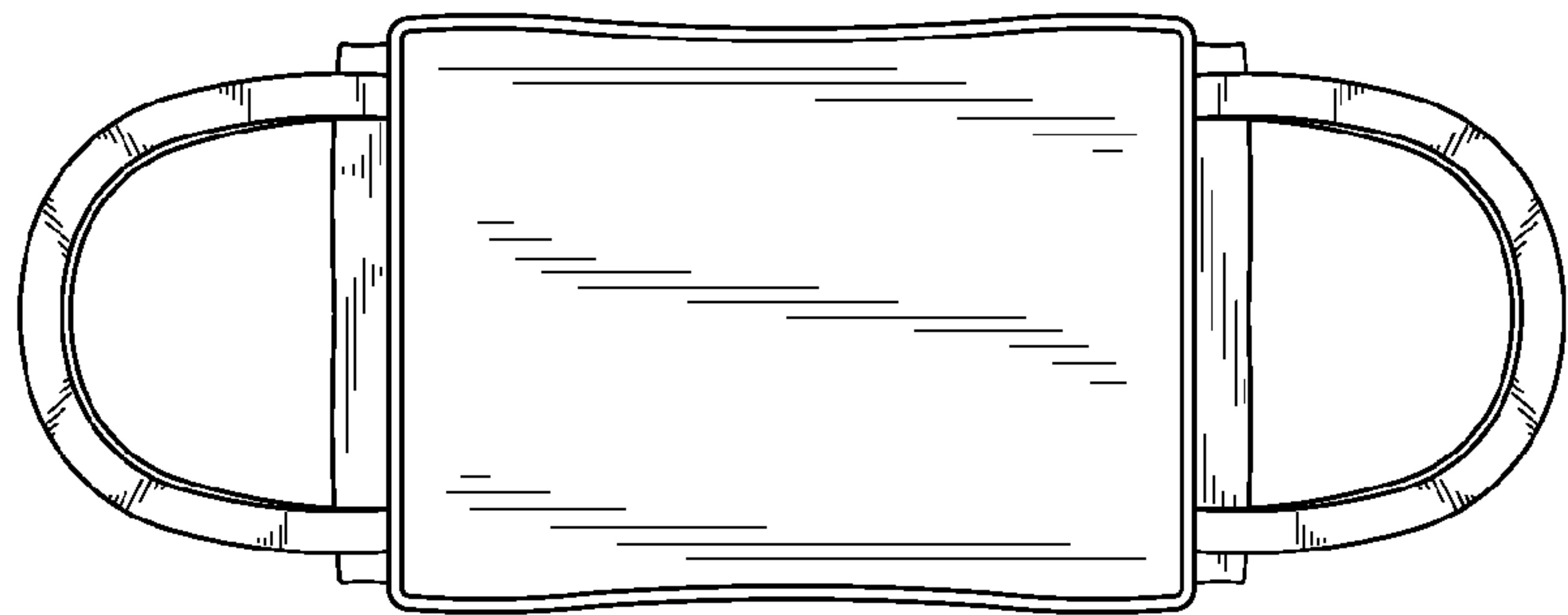

FIG. 10

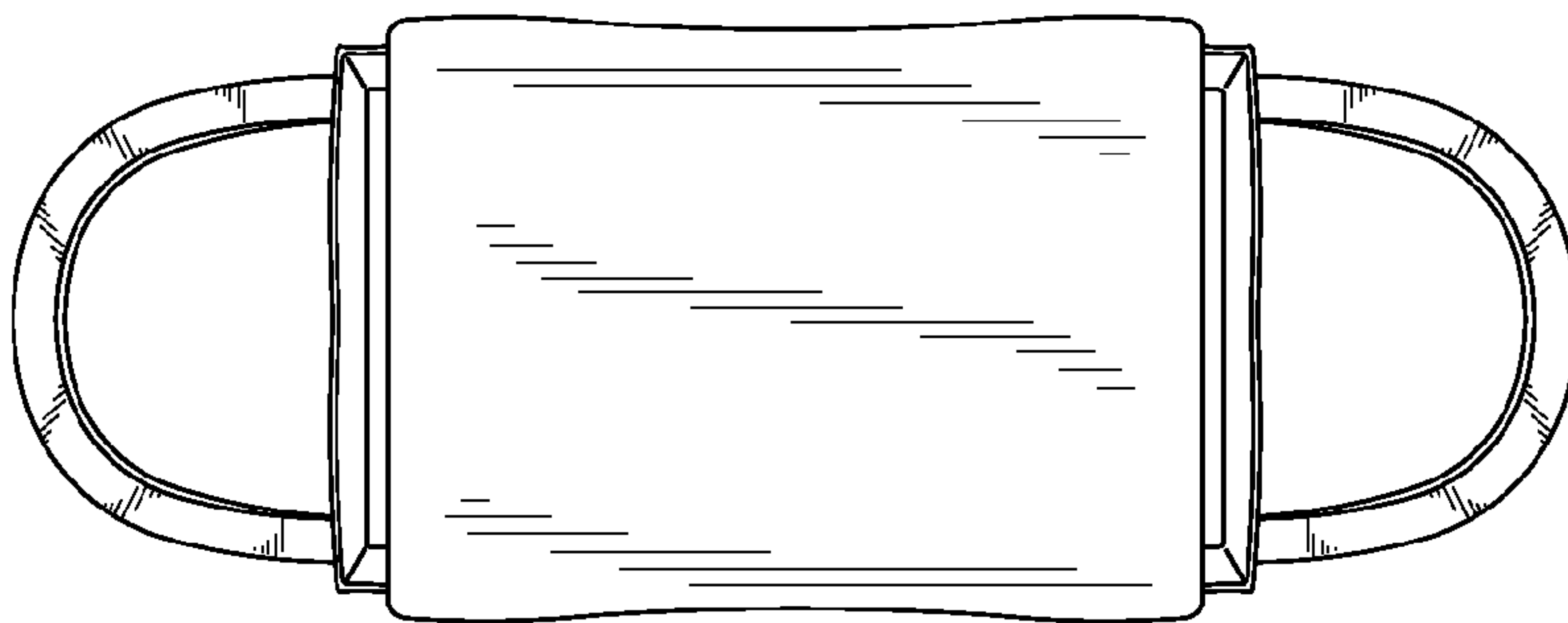

FIG. 11