



US00D608498S

(12) **United States Design Patent**
Beigel et al.

(10) **Patent No.:** **US D608,498 S**

(45) **Date of Patent:** **** Jan. 19, 2010**

(54) **HEADLAMP BEZEL AND TURN SIGNAL LENS OF A TRUCK VEHICLE**

(56) **References Cited**

U.S. PATENT DOCUMENTS

(75) Inventors: **David J. Beigel**, Payne, OH (US);
Marcey K. Collins, Fort Wayne, IN (US); **William Ratliff**, Commerce Township, MI (US); **Ronald E. Schoon**, Fort Wayne, MI (US); **Anthony Lynn Schroeder**, Leo, IN (US); **Jaimi Smith**, Lake Orion, MI (US); **Kris K. Timmerman**, Huntertown, IN (US); **Robert Scott Tirey**, Fort Wayne, IN (US); **Bruce Youngs**, Novi, MI (US); **Joseph E. Otto**, Fort Wayne, IN (US); **Pradhan Subhransu**, Akurdi, IN (US)

D485,934 S * 1/2004 Tsai D26/139
D499,202 S * 11/2004 Tsai D26/139
D513,644 S * 1/2006 Ruzicka et al. D26/139
D544,641 S * 6/2007 Elwell et al. D26/139

* cited by examiner

Primary Examiner—Marcus A Jackson
(74) *Attorney, Agent, or Firm*—Jeffrey P. Calfa; Mark C. Bach; Gerald W. Askew

(73) Assignee: **Mahindra Navistar Automotives Limited** (IN)

(57) **CLAIM**

The ornamental design for a headlamp bezel and turn signal lens of a truck vehicle, as shown and described.

(**) Term: **14 Years**

DESCRIPTION

(21) Appl. No.: **29/341,260**

(22) Filed: **Aug. 3, 2009**

(51) **LOC (9) Cl.** **26-99**

(52) **U.S. Cl.** **D26/139**

(58) **Field of Classification Search** D26/28–36,
D26/139; 362/459–468, 475–478, 485–487

FIG. 1 is a left, front perspective view of a headlamp bezel and turn signal lens of a truck vehicle showing our new design;

FIG. 2 is a front view thereof;

FIG. 3 is a left view thereof; and,

FIG. 4 is a top view thereof.

See application file for complete search history.

1 Claim, 2 Drawing Sheets

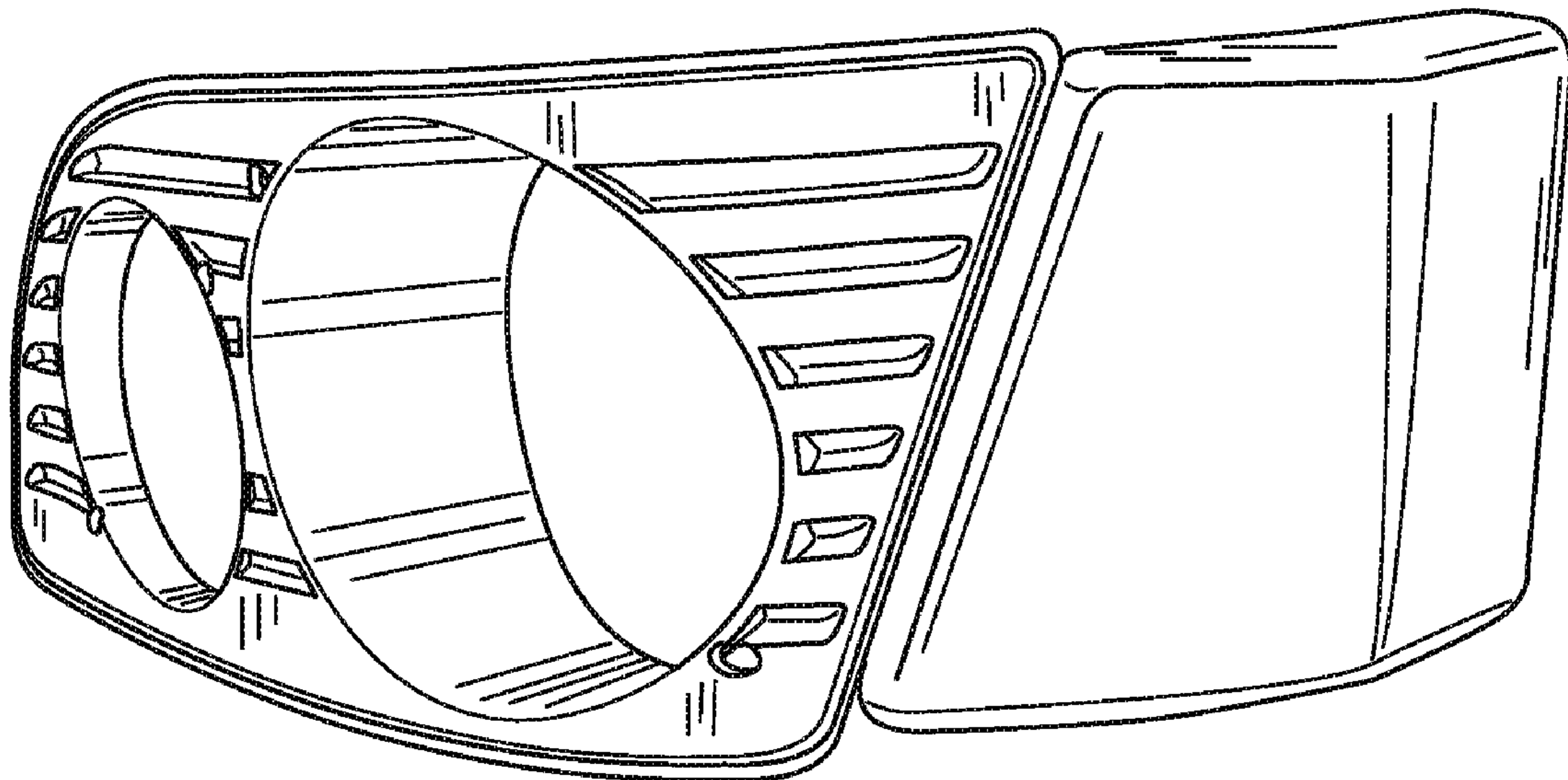

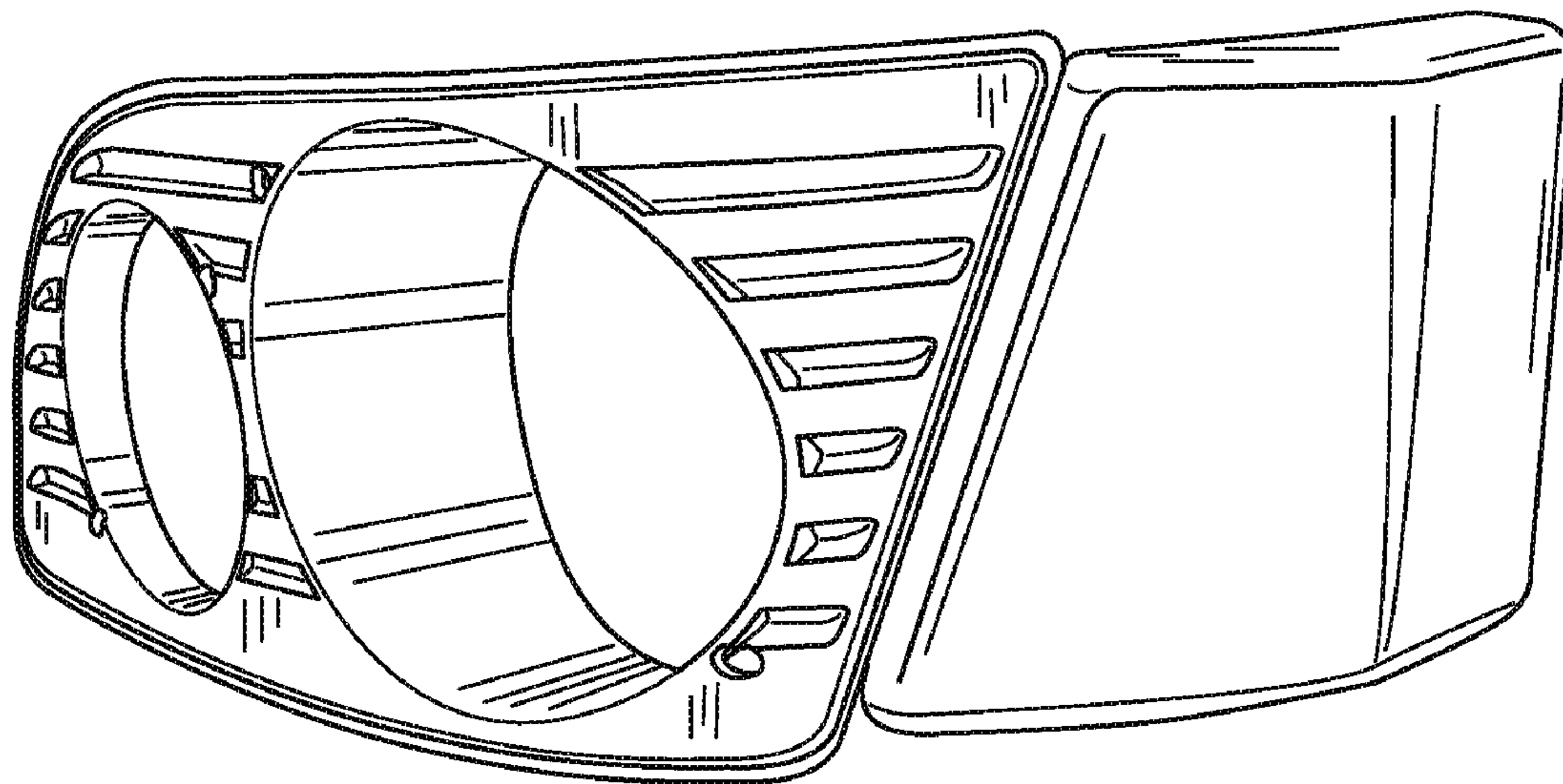

FIG. 1

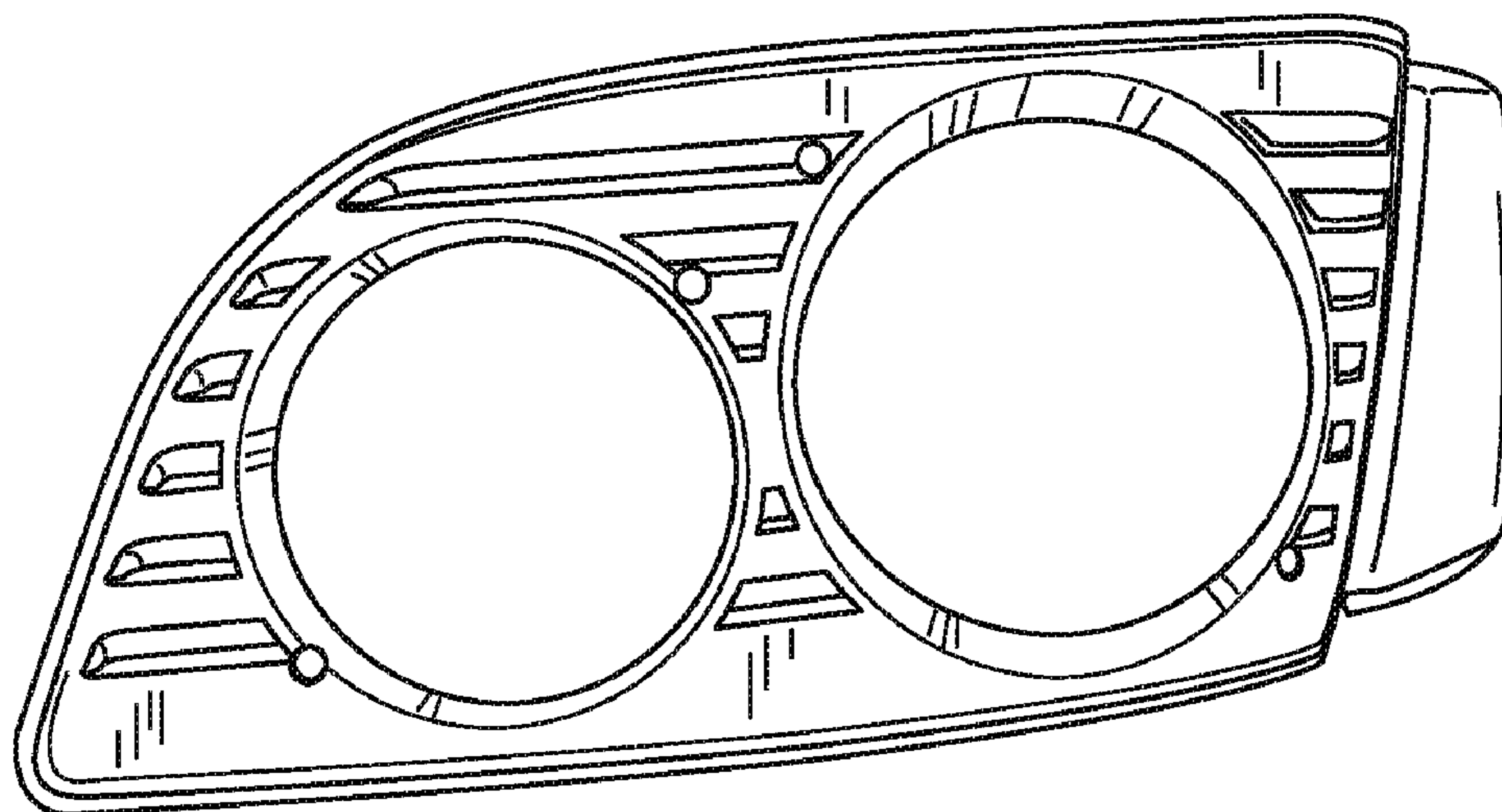

FIG. 2

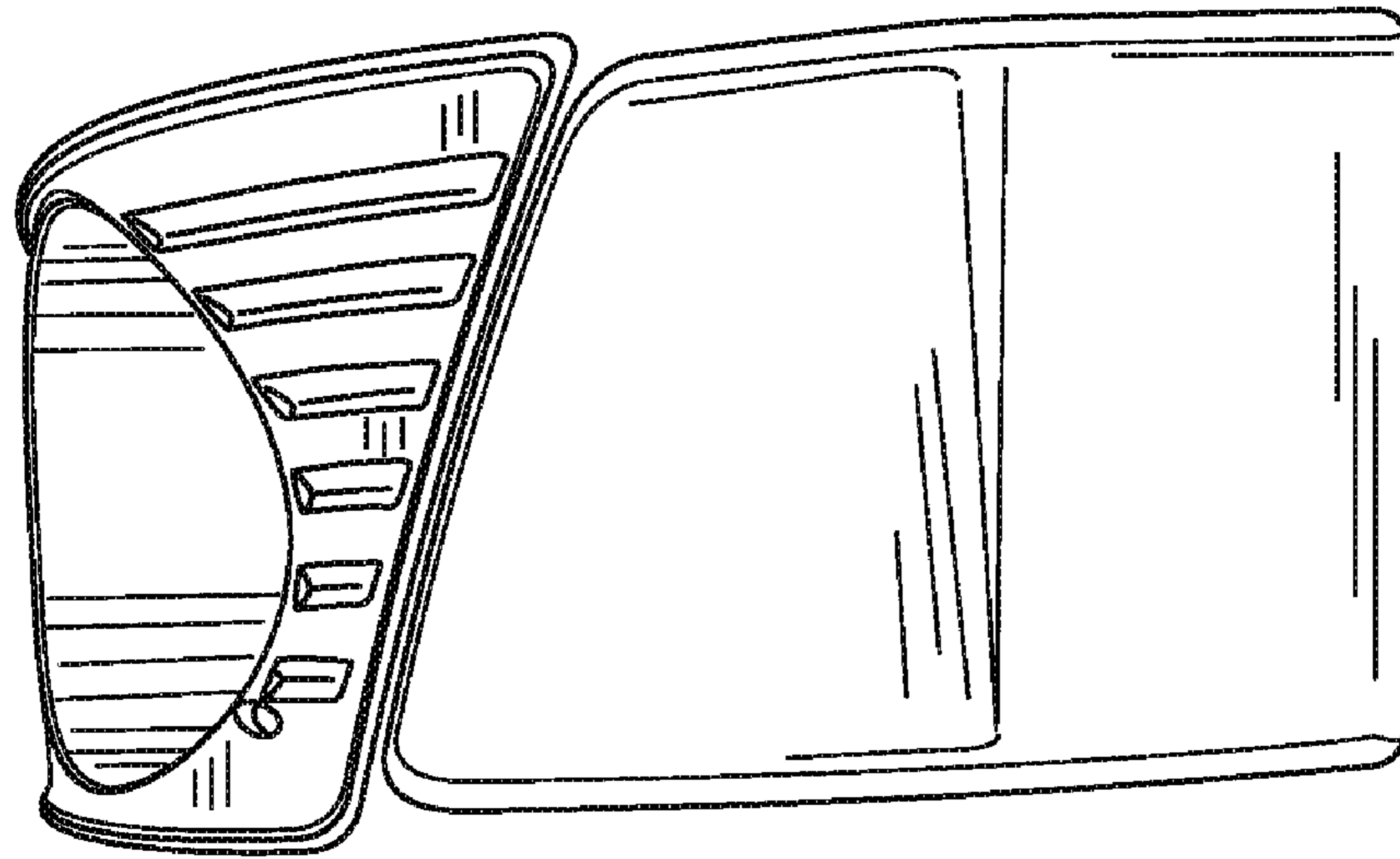

FIG. 3

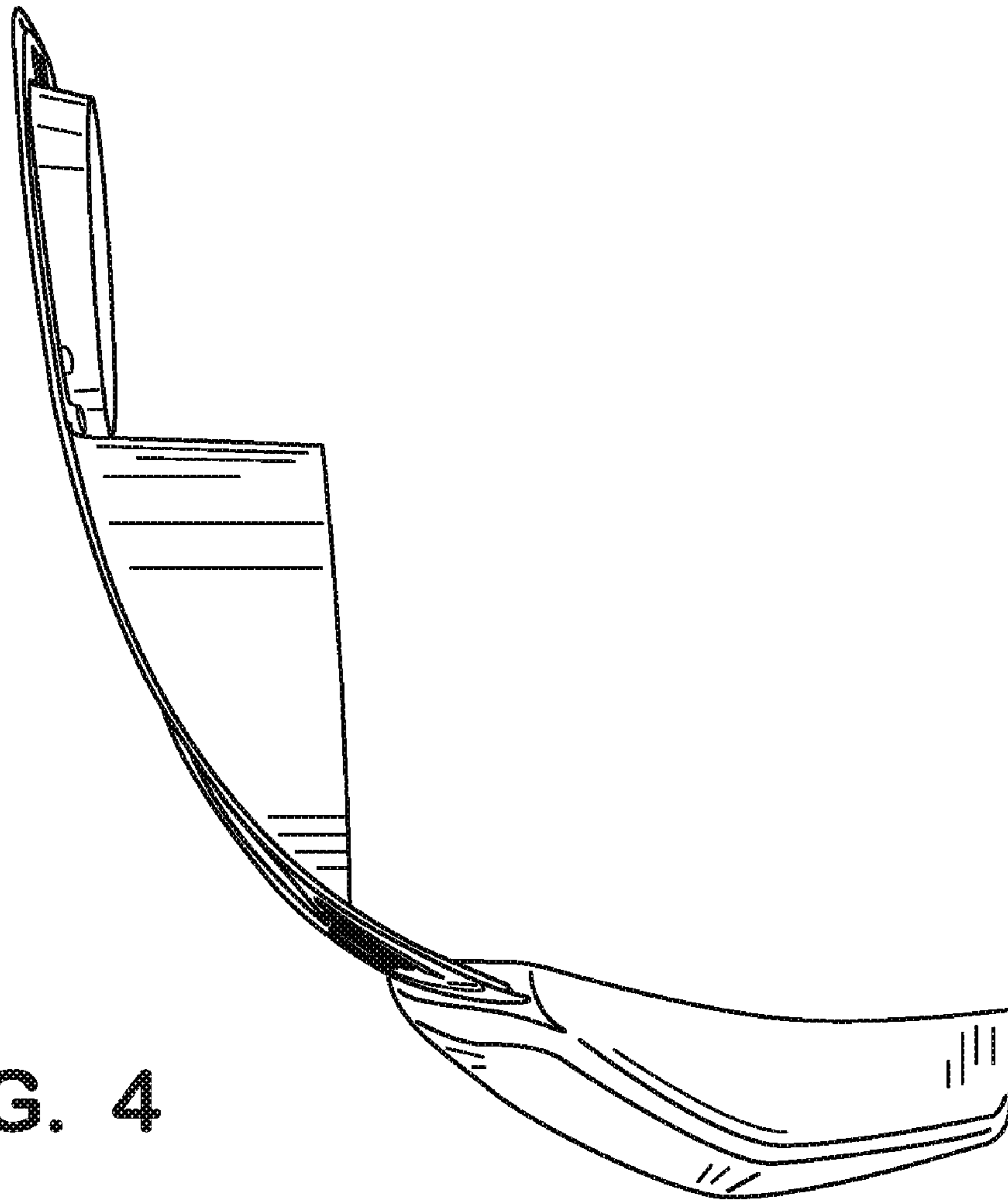

FIG. 4