



US00D607763S

(12) **United States Design Patent**
Morel

(10) **Patent No.:** **US D607,763 S**
(45) **Date of Patent:** **** Jan. 12, 2010**

(54) **ELECTRICAL VOLTAGE OR CURRENT SENSOR**

(75) Inventor: **Pascal Morel**, Saint Pierre en Faucigny (FR)

(73) Assignee: **Liaisons Electroniques-Mechaniques**. (CH)

(**) Term: **14 Years**

(21) Appl. No.: **29/325,925**

(22) Filed: **Oct. 8, 2008**

(30) **Foreign Application Priority Data**

Apr. 8, 2008 (CH) 2008/00346

(51) **LOC (9) Cl.** **10-04**

(52) **U.S. Cl.** **D10/79; D10/78**

(58) **Field of Classification Search** D10/75, D10/78, 79; 324/117 H, 117 R

See application file for complete search history.

(56) **References Cited**

U.S. PATENT DOCUMENTS

D401,171	S	*	11/1998	Cattaneo	D10/78
6,005,383	A	*	12/1999	Savary et al.	324/117 H
D420,297	S	*	2/2000	Cattaneo	D10/78
D494,078	S	*	8/2004	Vuillermoz	D10/75
D505,870	S	*	6/2005	Vuillermoz	D10/75
D506,153	S	*	6/2005	Morel	D10/78
D510,881	S	*	10/2005	Morel	D10/78

(Continued)

OTHER PUBLICATIONS

“Voltage Transducer LV 100-4000/SP2”, LEM Components, www.lem.com, 2 pp.

(Continued)

Primary Examiner—Antoine D Davis

(74) *Attorney, Agent, or Firm*—Baker & Daniels LLP

(57) **CLAIM**

The ornamental design for an electrical voltage or current sensor, as shown and described.

DESCRIPTION

FIG. 1 is a top perspective view of the first embodiment of the sensor from a first end;

FIG. 2 is a top perspective view of the sensor of FIG. 1 from a second end;

FIG. 3 is a bottom view of the sensor of FIG. 1;

FIG. 4 is an end view of the sensor of FIG. 1;

FIG. 5 is a top elevational view of the sensor of FIG. 1;

FIG. 6 is a right side view of the sensor of FIG. 1;

FIG. 7 is a right side view of the sensor of FIG. 1;

FIG. 8 is an end view of the sensor of FIG. 1;

FIG. 9 is a top perspective view of the second embodiment of the sensor from a first end;

FIG. 10 is a top perspective view of the sensor of FIG. 9 from a second end;

FIG. 11 is a bottom view of the sensor of FIG. 9;

FIG. 12 is an end view of the sensor of FIG. 9;

FIG. 13 is a top elevational view of the sensor of FIG. 9;

FIG. 14 is a right side view of the sensor of FIG. 9;

FIG. 15 is a right side view of the sensor of FIG. 9; and,

FIG. 16 is an end view of the sensor of FIG. 9.

1 Claim, 6 Drawing Sheets

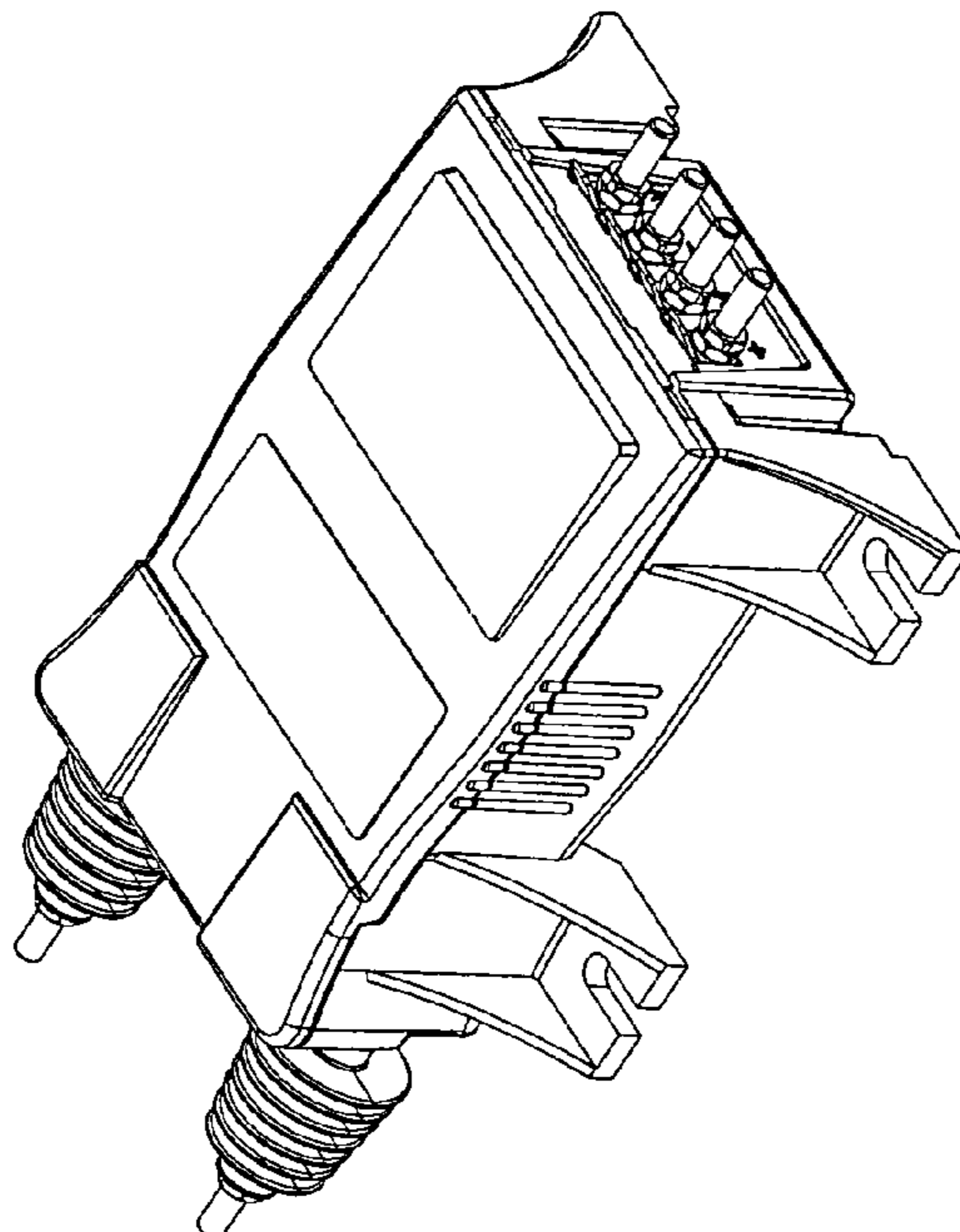

US D607,763 S

Page 2

U.S. PATENT DOCUMENTS

D511,112 S * 11/2005 Takada D10/75
2008/0048642 A1* 2/2008 Aratani et al. 324/117 H

OTHER PUBLICATIONS

“Voltage Transducer CV 4-8000/SP2”, LEM , www.lem.com, pp. 1-3.

“Capteurs de tension Gamme VS”, ABB Entrelec Control Division, <http://www.abb.com>, 8 pp.

“NV100-3000V/SP7 Voltage Transducer”, Times Electric Group, Ningbo Branch, www.zelrinb.com.cn, 2 pp.

“Voltage Transducer OV 200-4200/SP4”, LEM Components, www.lem.com, pp. 1-3.

* cited by examiner

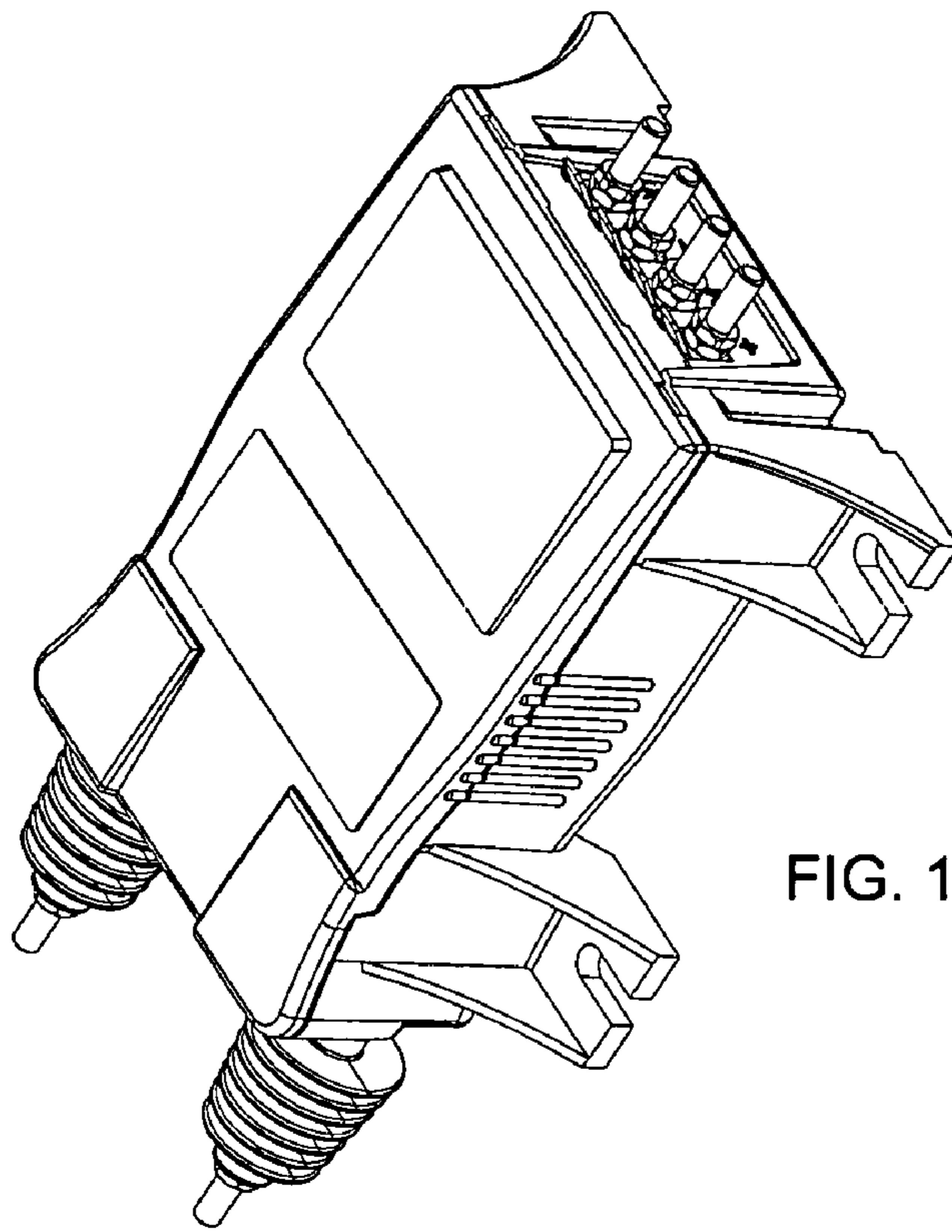
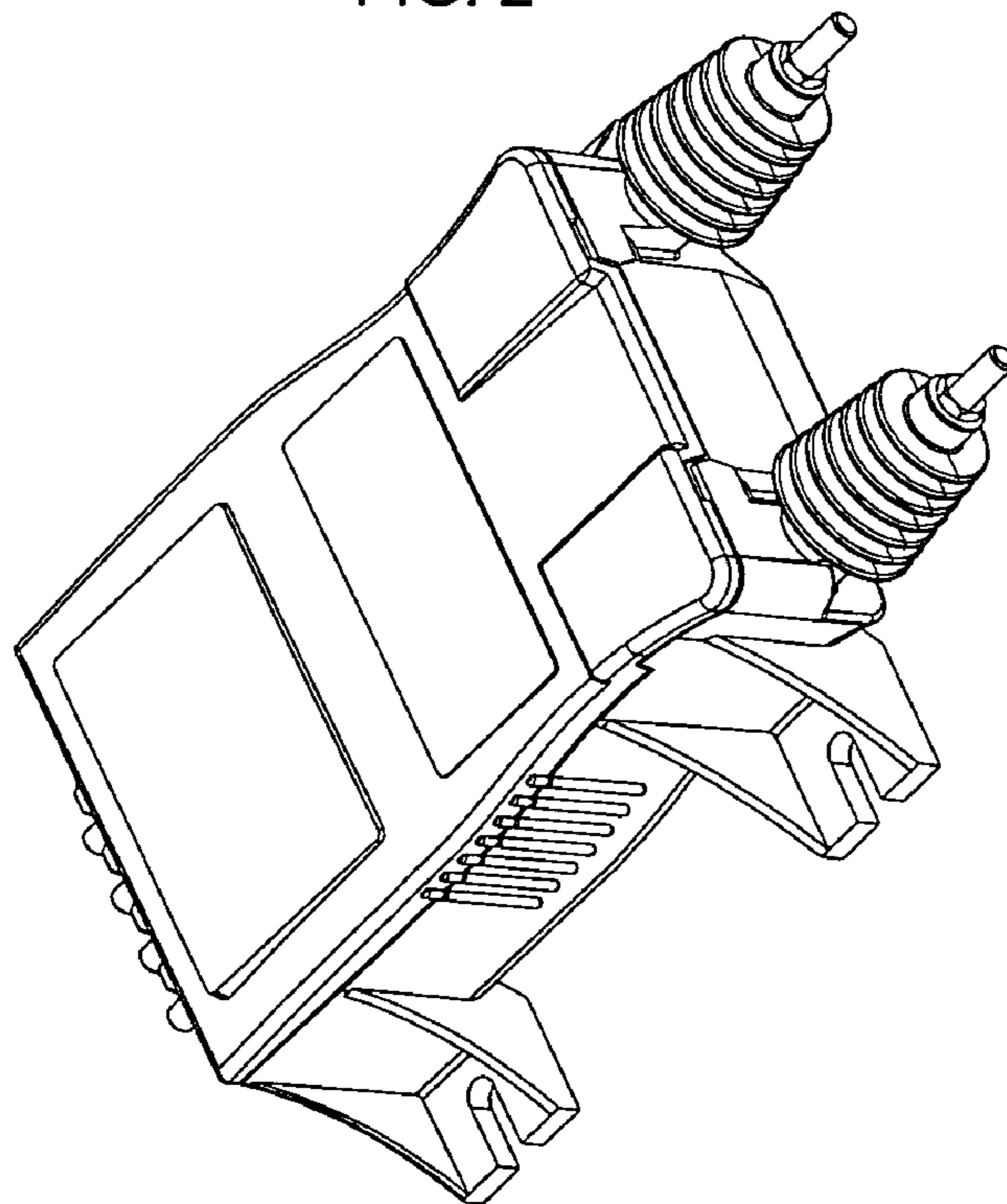

FIG. 1

FIG. 2



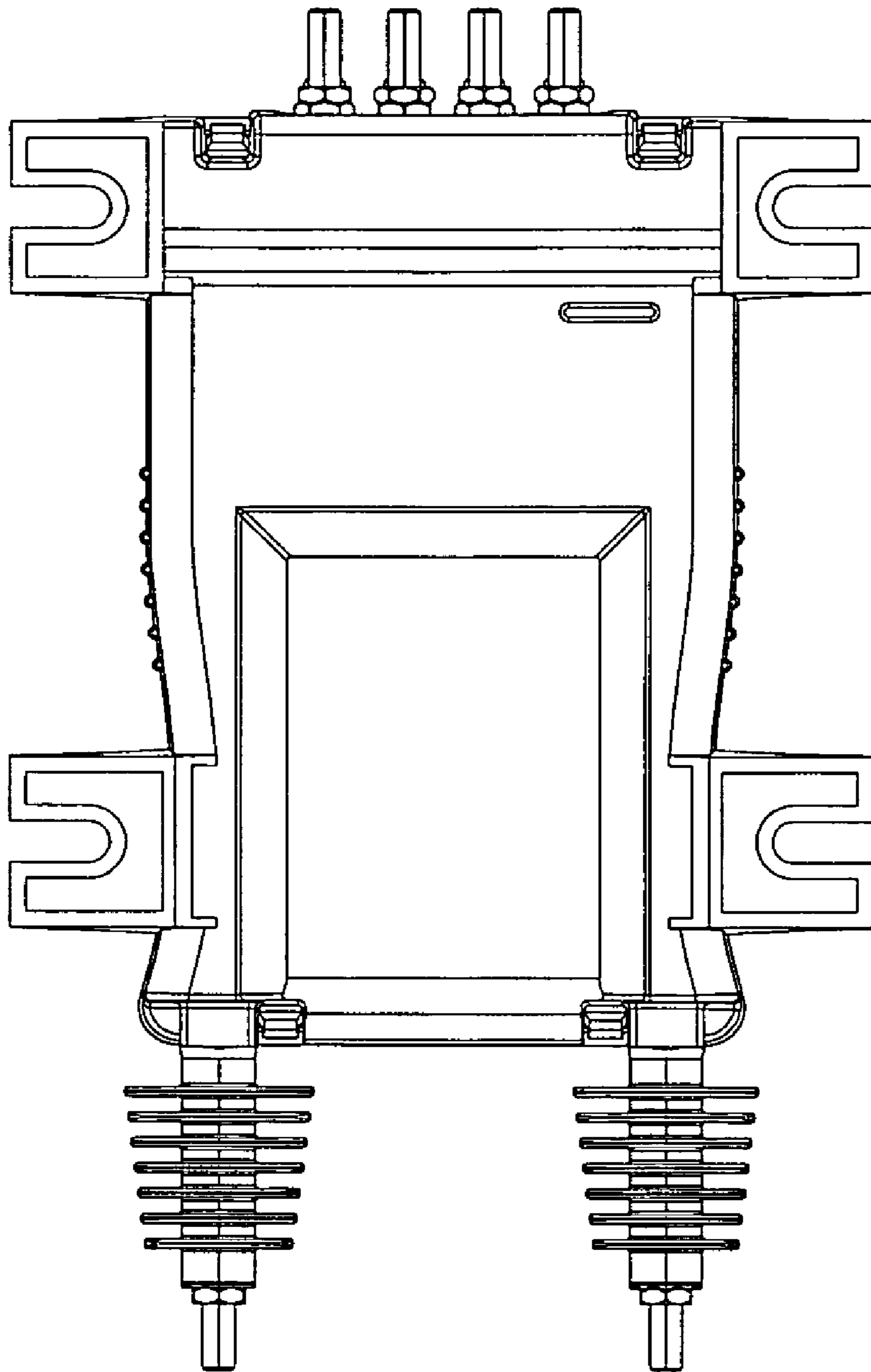

FIG. 3

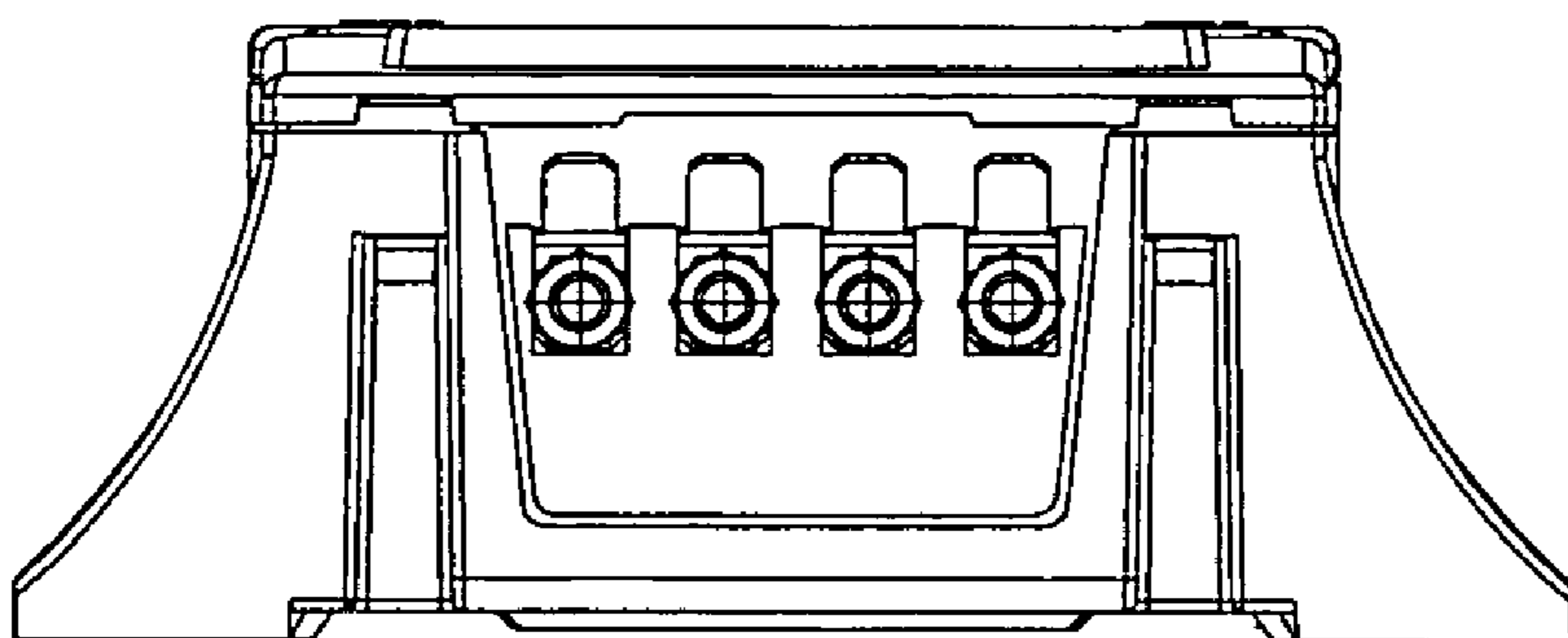

FIG. 4

FIG. 6

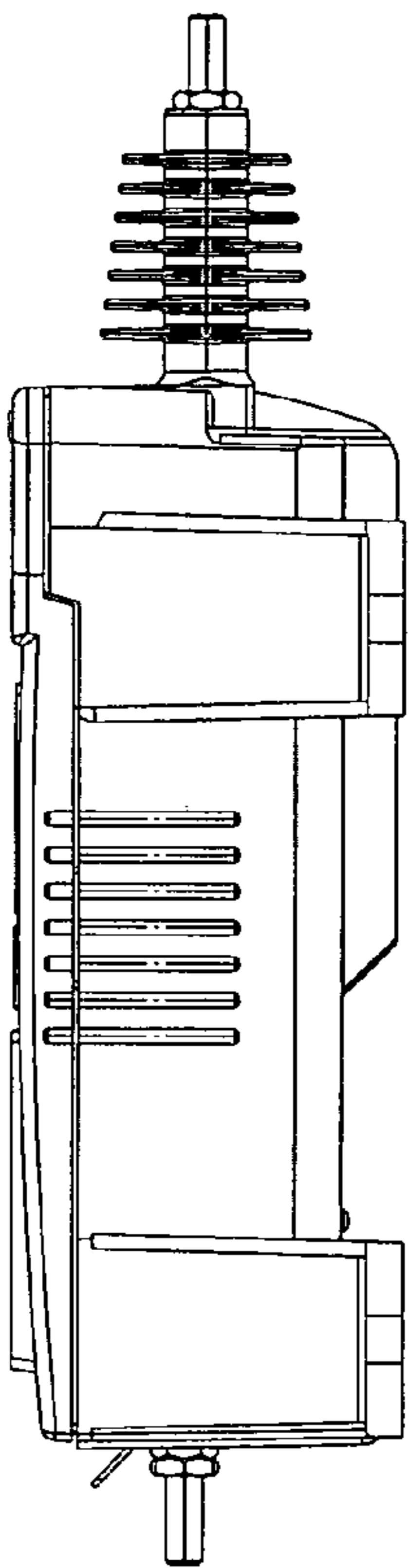

FIG. 5

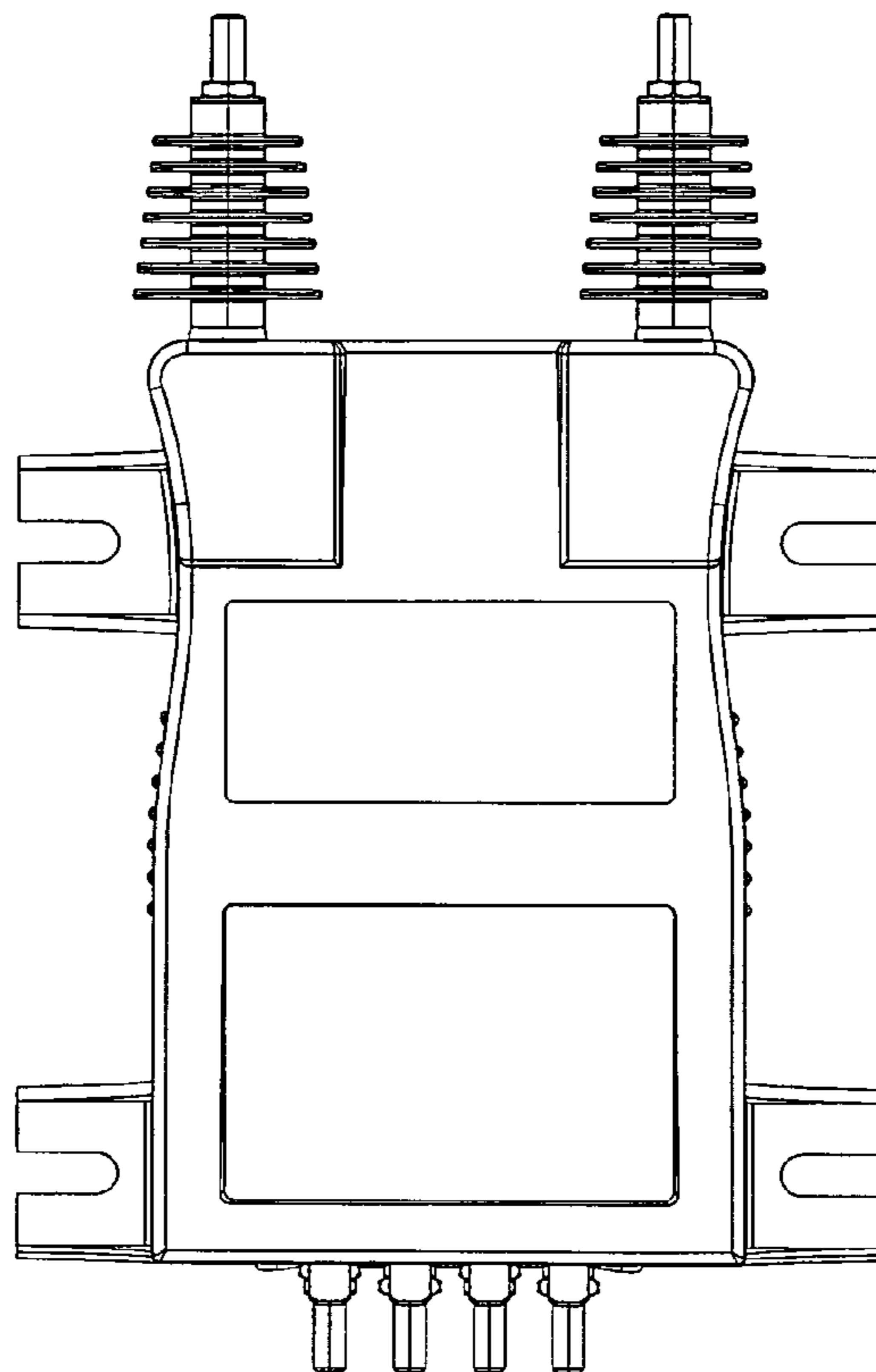

FIG. 7

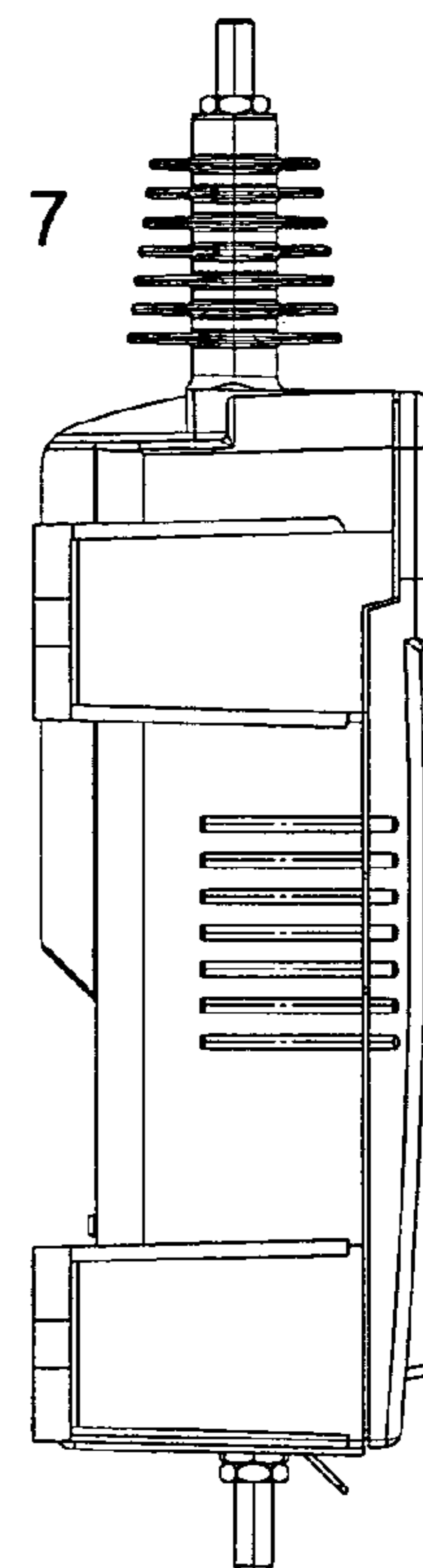
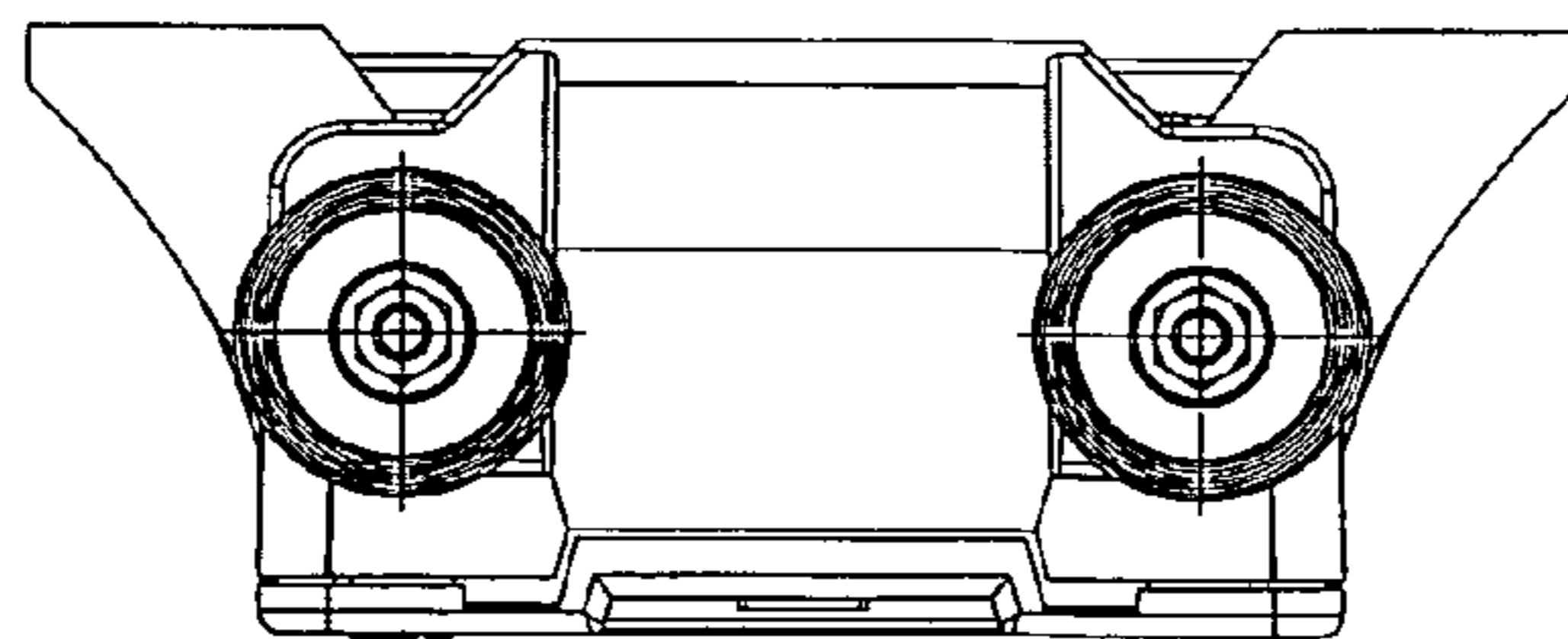

FIG. 8



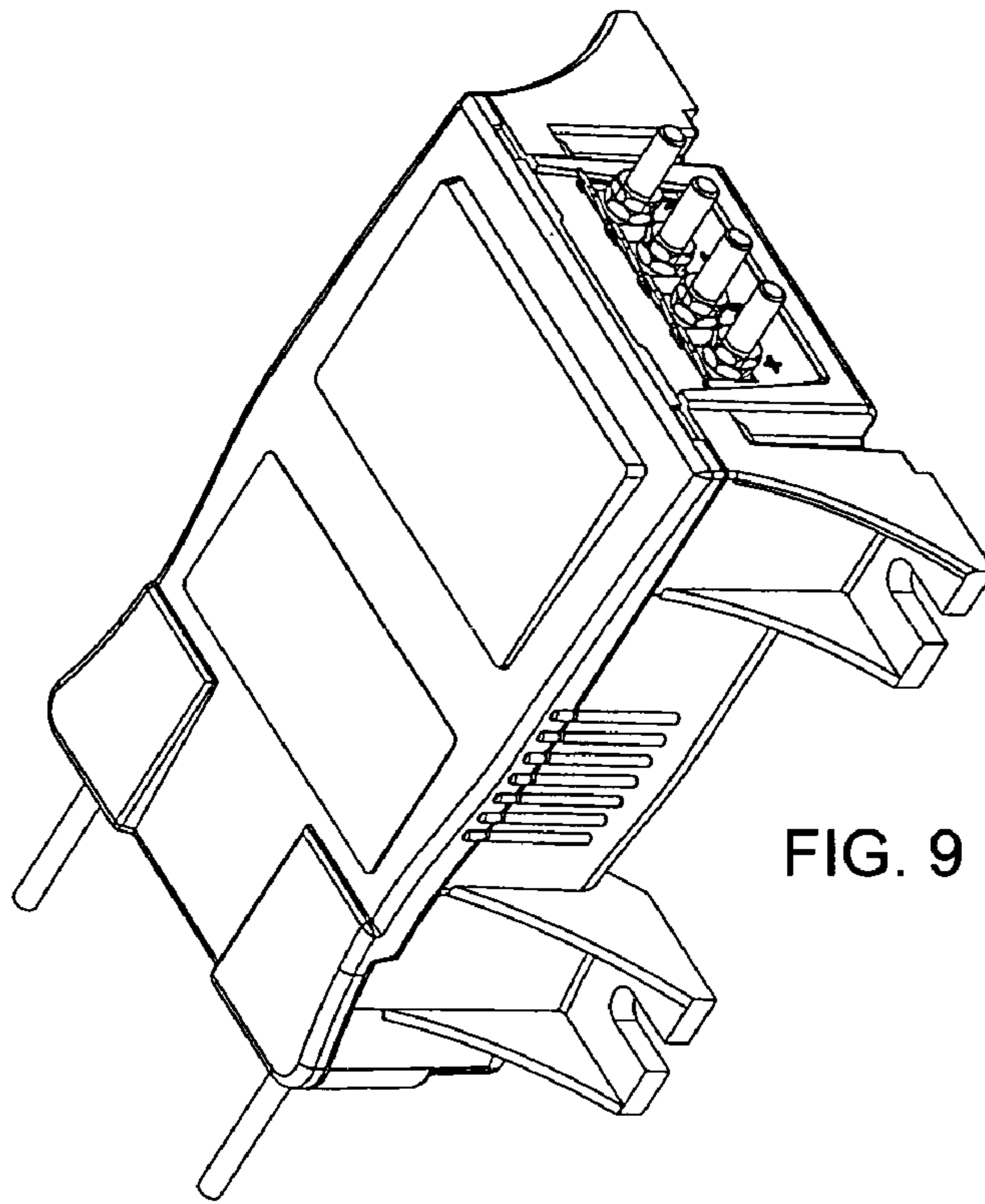
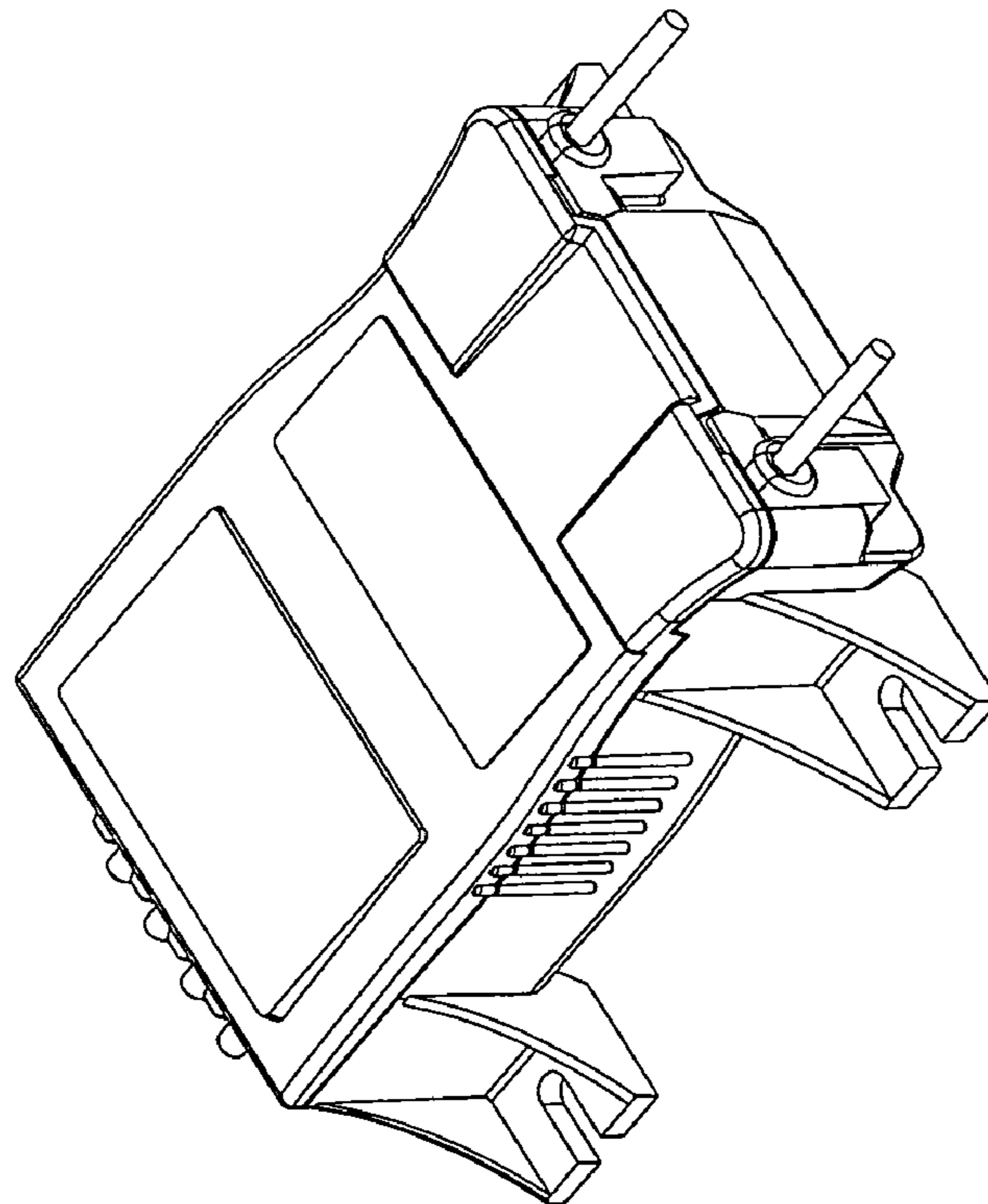

FIG. 9

FIG. 10



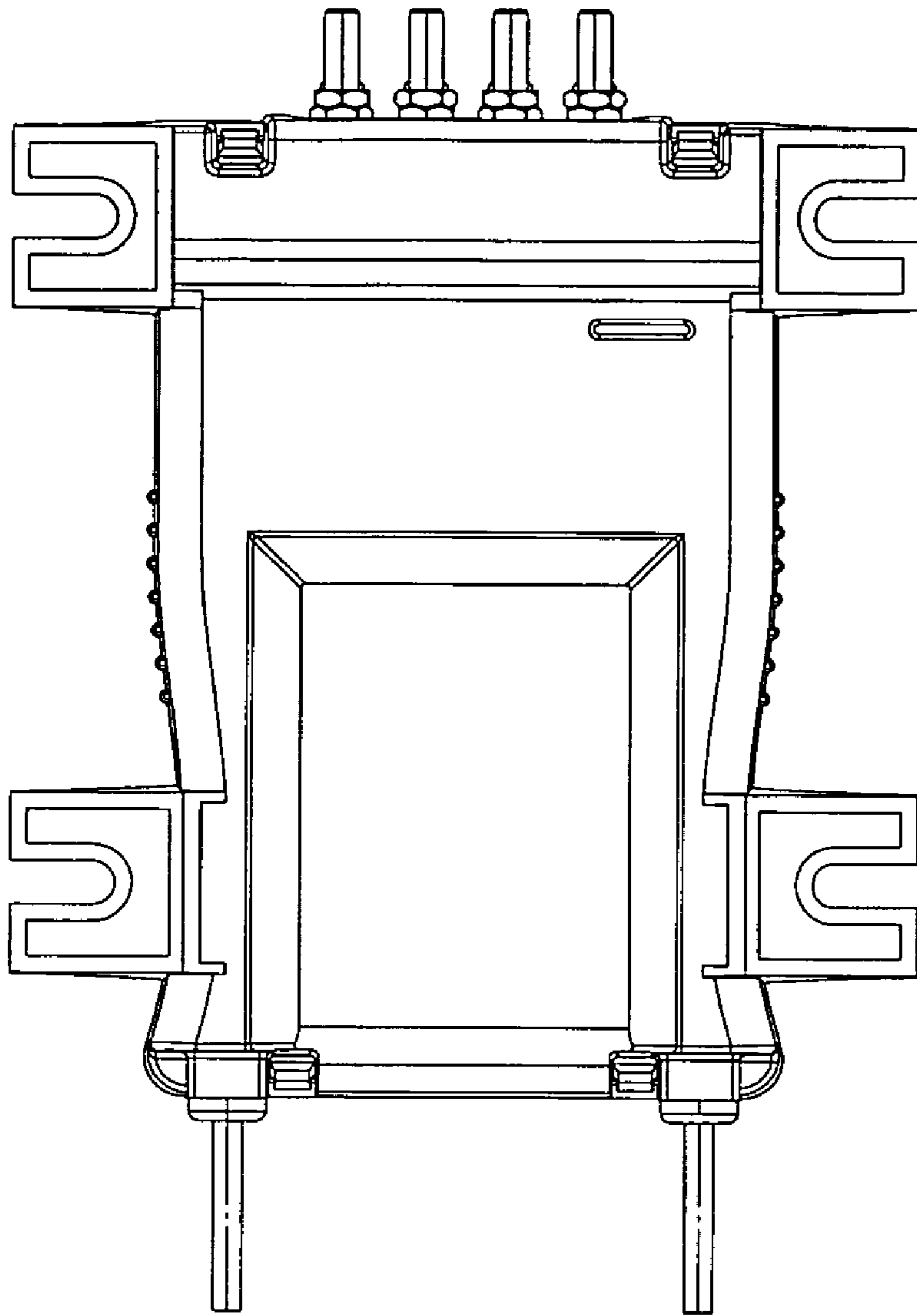

FIG. 11

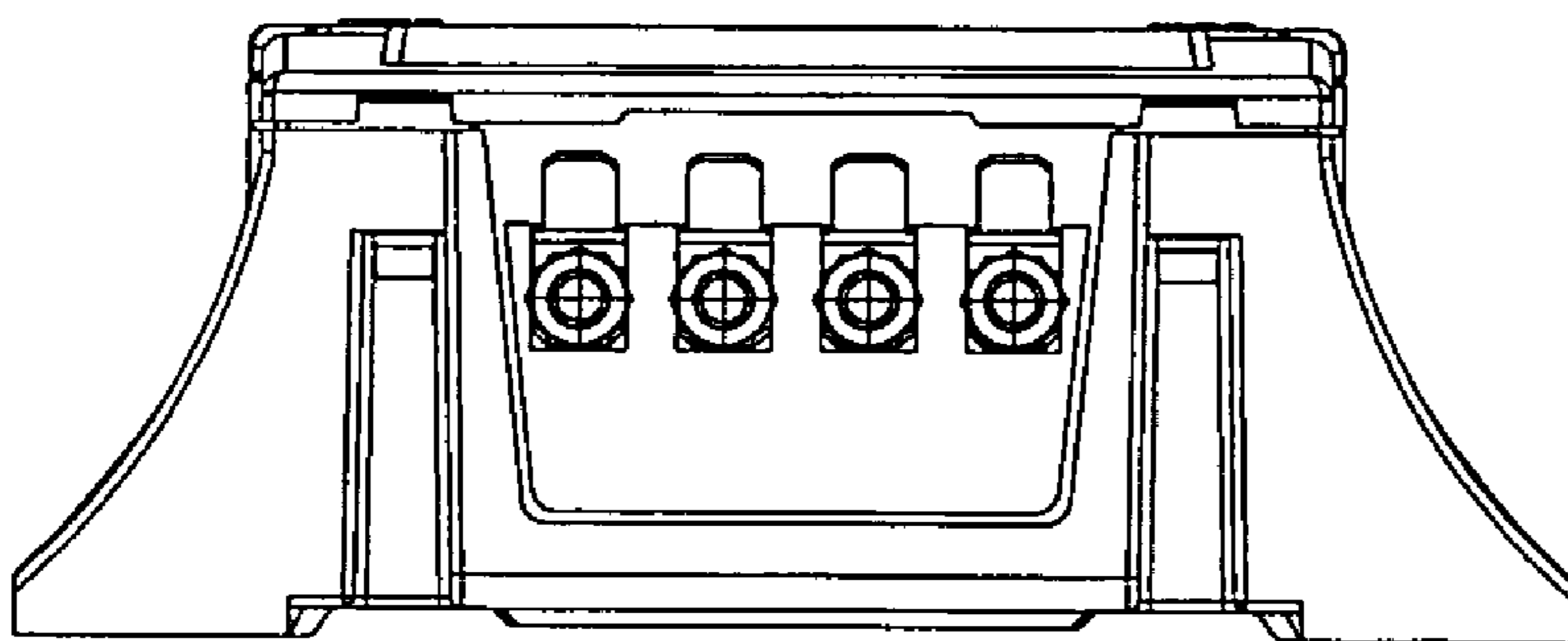

FIG. 12

FIG. 14

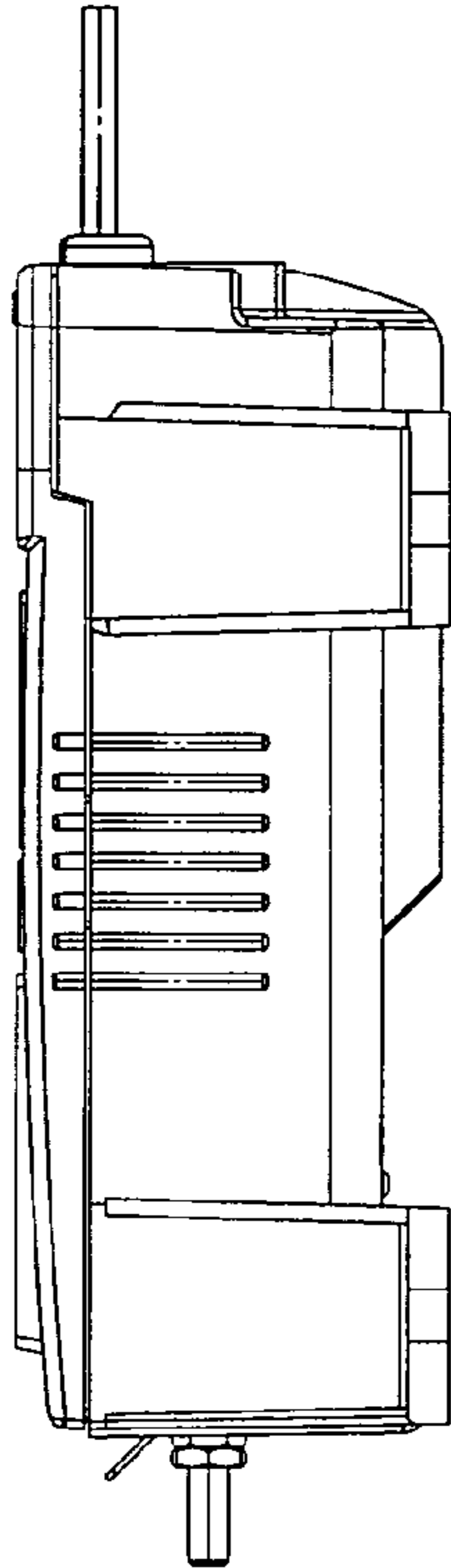

FIG 13

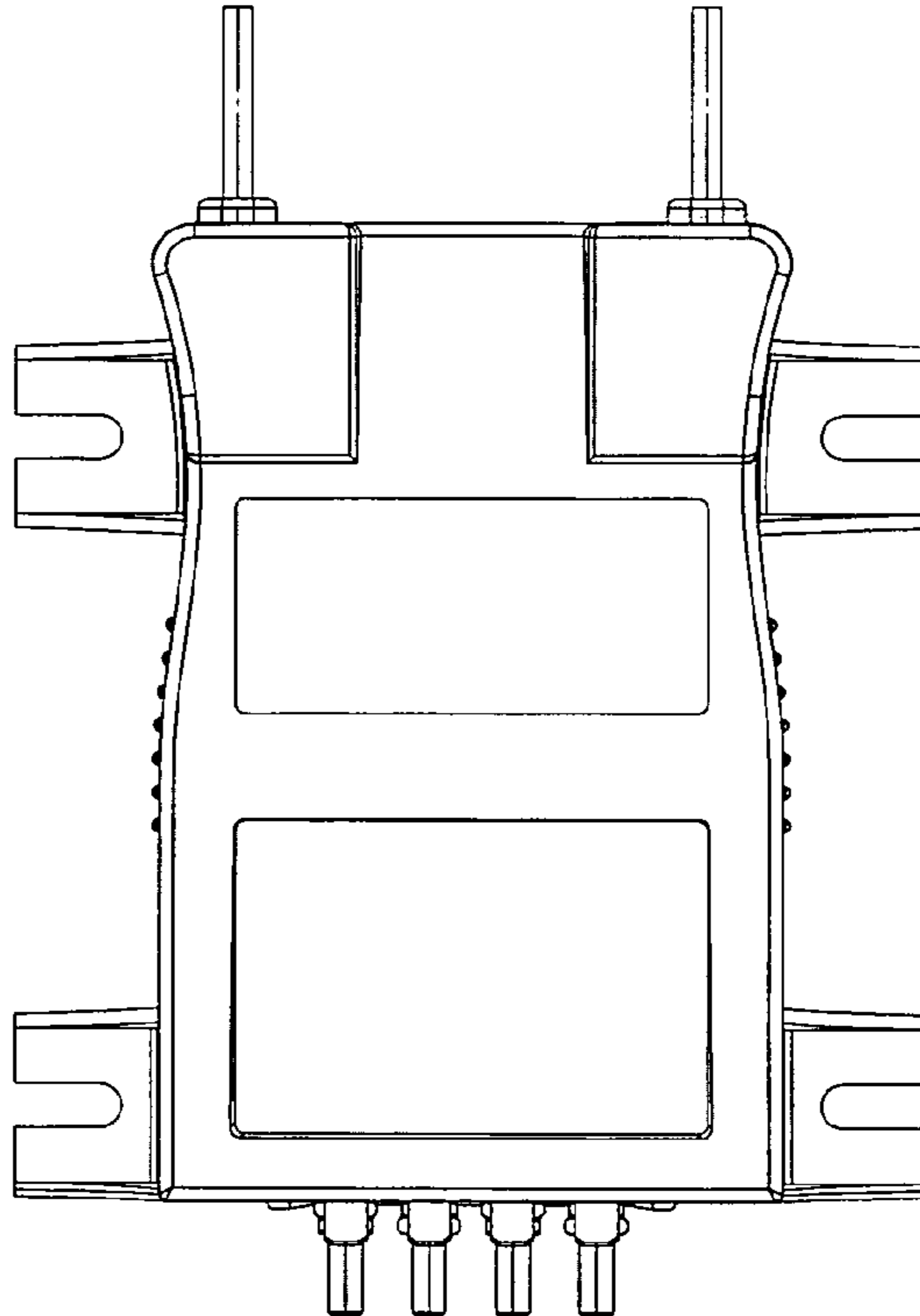

FIG. 15

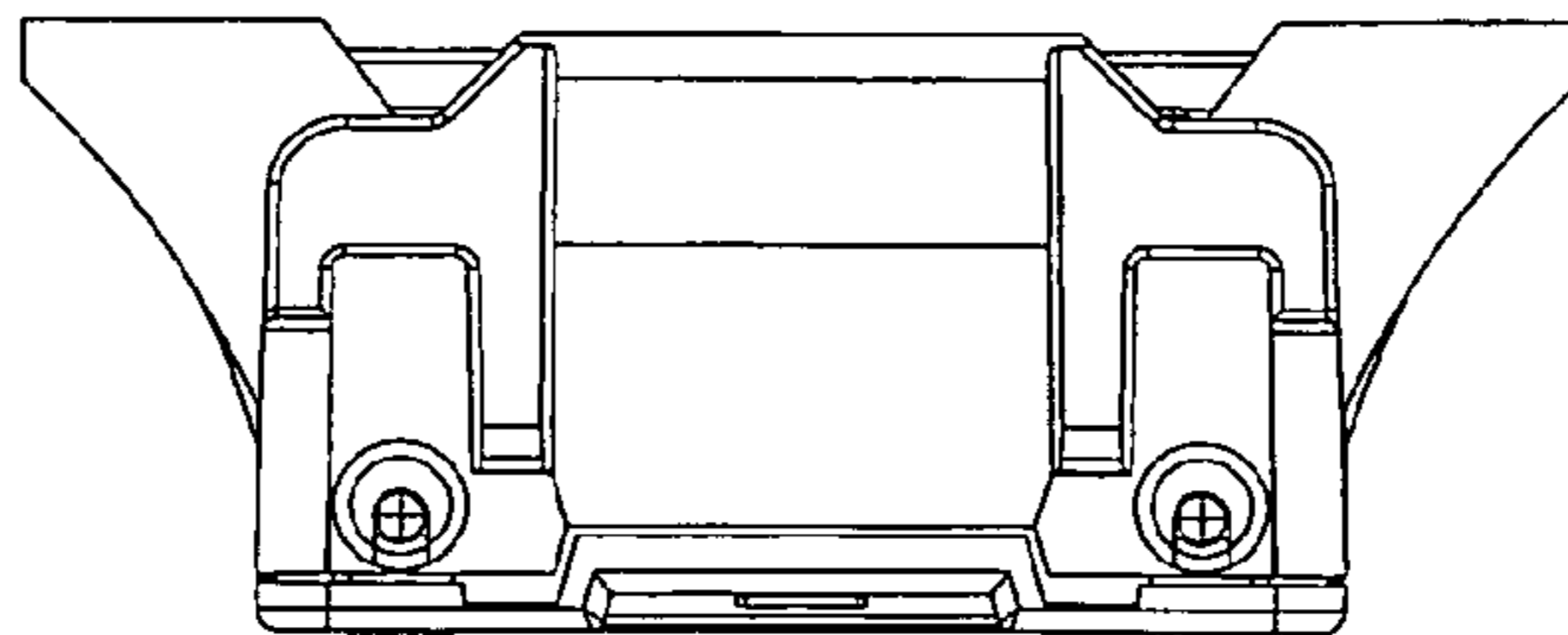
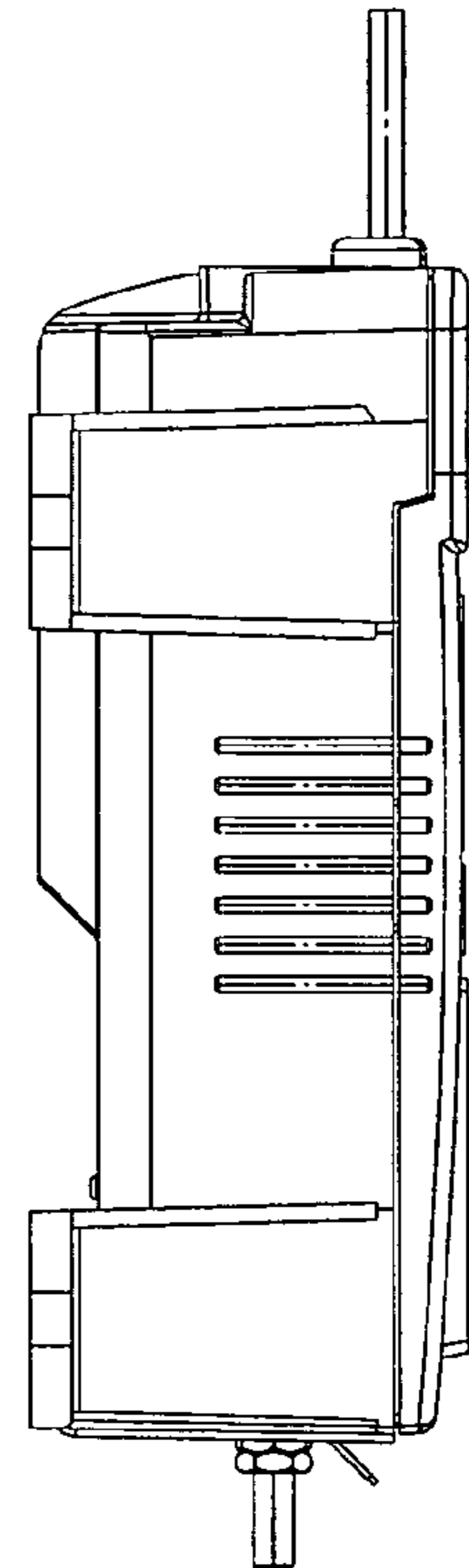

FIG.16