



US00D607472S

(12) **United States Design Patent**  
**Nishi et al.**

(10) **Patent No.:** **US D607,472 S**  
(45) **Date of Patent:** **\*\* Jan. 5, 2010**

(54) **PUMP IMPELLER**

(75) Inventors: **Yasuyuki Nishi**, Hyogo (JP); **Seiji Kawaguchi**, Hyogo (JP); **Satoshi Mashita**, Hyogo (JP); **Kazuki Takeuchi**, Hyogo (JP); **Nobukazu Tanaka**, Hyogo (JP); **Akihiro Ando**, Hyogo (JP); **Yasuhide Okazaki**, Hyogo (JP); **Junya Enomoto**, Hyogo (JP); **Arata Funasaka**, Hyogo (JP); **Terumasa Okizoe**, Hyogo (JP)

(73) Assignee: **ShinMaywa Industries, Ltd.**, Hyogo (JP)

(\*\*) Term: **14 Years**

(21) Appl. No.: **29/334,577**

(22) Filed: **Mar. 27, 2009**

(51) **LOC (9) Cl.** ..... **15-02**

(52) **U.S. Cl.** ..... **D15/7**

(58) **Field of Classification Search** ..... D15/7-9;  
D23/231, 232, 225; 417/410.1, 359, 415-416,  
417/234, 321, 265, 405

See application file for complete search history.

(56) **References Cited**

**U.S. PATENT DOCUMENTS**

D262,538 S \* 1/1982 Erikson ..... D15/7

(Continued)

**FOREIGN PATENT DOCUMENTS**

JP 2006-291937 A 10/2006

(Continued)

*Primary Examiner*—R. Seifert

(74) *Attorney, Agent, or Firm*—Roberts Mlotkowski Safran & Cole, P.C.; Thomas W. Cole

(57) **CLAIM**

The ornamental design for a pump impeller, as shown and described.

**DESCRIPTION**

FIG. 1 is the impeller viewed obliquely from above.

FIG. 2 is the impeller viewed obliquely from below.

FIG. 3 is the impeller viewed from front.

FIG. 4 is the impeller viewed from back.

FIG. 5 is the impeller viewed from right.

FIG. 6 is the impeller viewed from left.

FIG. 7 is the impeller viewed from above.

FIG. 8 is the impeller viewed from below.

FIG. 9 is a cross section taken along the line 9—9 of FIG. 7.

FIG. 10 is a cross section taken along the line 10—10 of FIG. 7.

FIG. 11 is a cross section taken along the line 11—11 of FIG. 7.

FIG. 12 is a cross section taken along the line 12—12 of FIG. 7.

FIG. 13 is the impeller without a lid, viewed from above.

FIG. 14 is a modified impeller, viewed obliquely from above.

FIG. 15 is the modified impeller, viewed obliquely from below.

FIG. 16 is the modified impeller, viewed from front.

FIG. 17 is the modified impeller, viewed from back.

FIG. 18 is the modified impeller, viewed from right.

FIG. 19 is the modified impeller, viewed from left.

FIG. 20 is the modified impeller, viewed from above.

FIG. 21 is the modified impeller, viewed from below.

FIG. 22 is a cross section taken along the line 22—22 of FIG. 20.

FIG. 23 is a cross section taken along the line 23—23 of FIG. 20.

FIG. 24 is a cross section taken along the line 24—24 of FIG. 20; and,

FIG. 25 is a cross section taken along the line 25—25 of FIG. 20.

The impeller is provided in a pump, and draws in liquid through an inlet in the bottom shown in FIG. 2. The liquid passes through the flow path formed inside the impeller shown in the cross sections of FIGS. 9-12. The impeller has a hollow part opening at the top of the impeller body shown in FIG. 13 and a lid screwed to the top to close the hollow part.

**1 Claim, 13 Drawing Sheets**

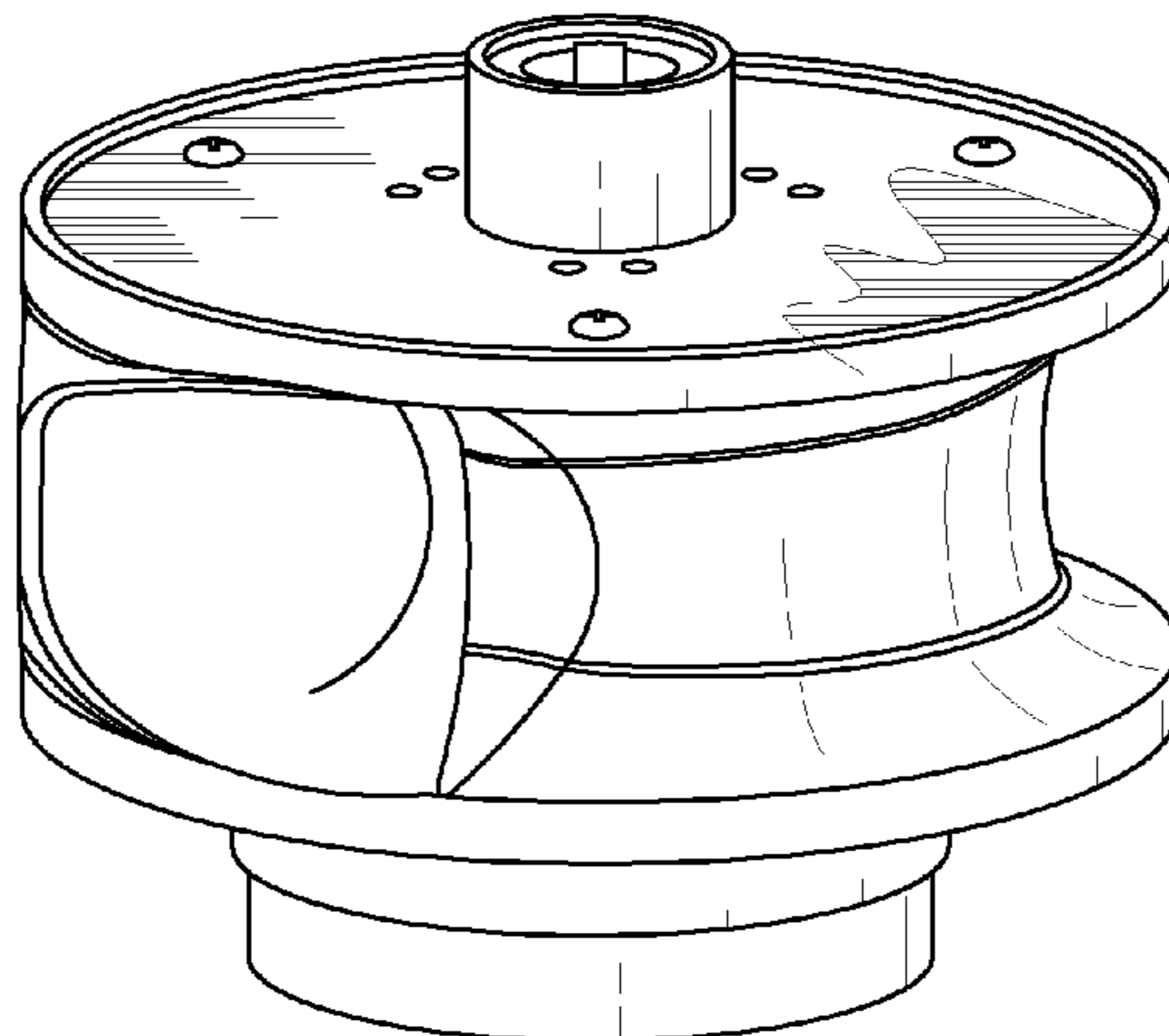

# US D607,472 S

Page 2

---

U.S. PATENT DOCUMENTS			
		JP	1290074 S 12/2006
D268,112 S *	3/1983 Sugiura	JP	1290390 S 12/2006
4,666,373 A *	5/1987 Sugiura	JP	1290391 S 12/2006
D443,281 S *	6/2001 Sodergard	JP	1295382 S 3/2007
D514,125 S *	1/2006 Cook	JP	1295624 S 3/2007
2005/0013688 A1	1/2005 Nishi et al.	JP	1315873 S 11/2007
		JP	1316218 S 12/2007
FOREIGN PATENT DOCUMENTS			
JP	1290072 S	JP	1316510 S 12/2007
JP	1290073 S	JP	1316511 S 12/2007

\* cited by examiner

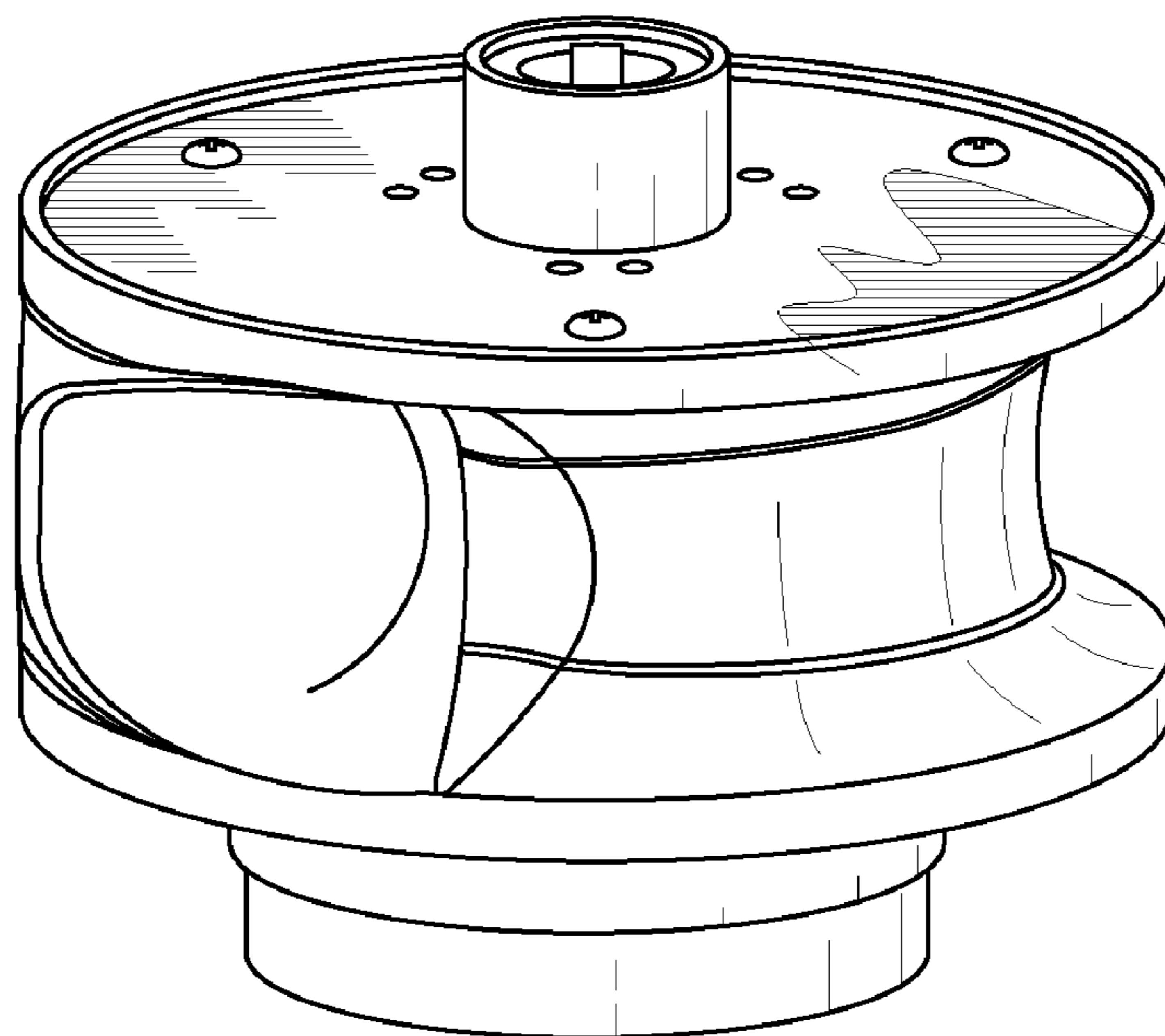

FIG. 1

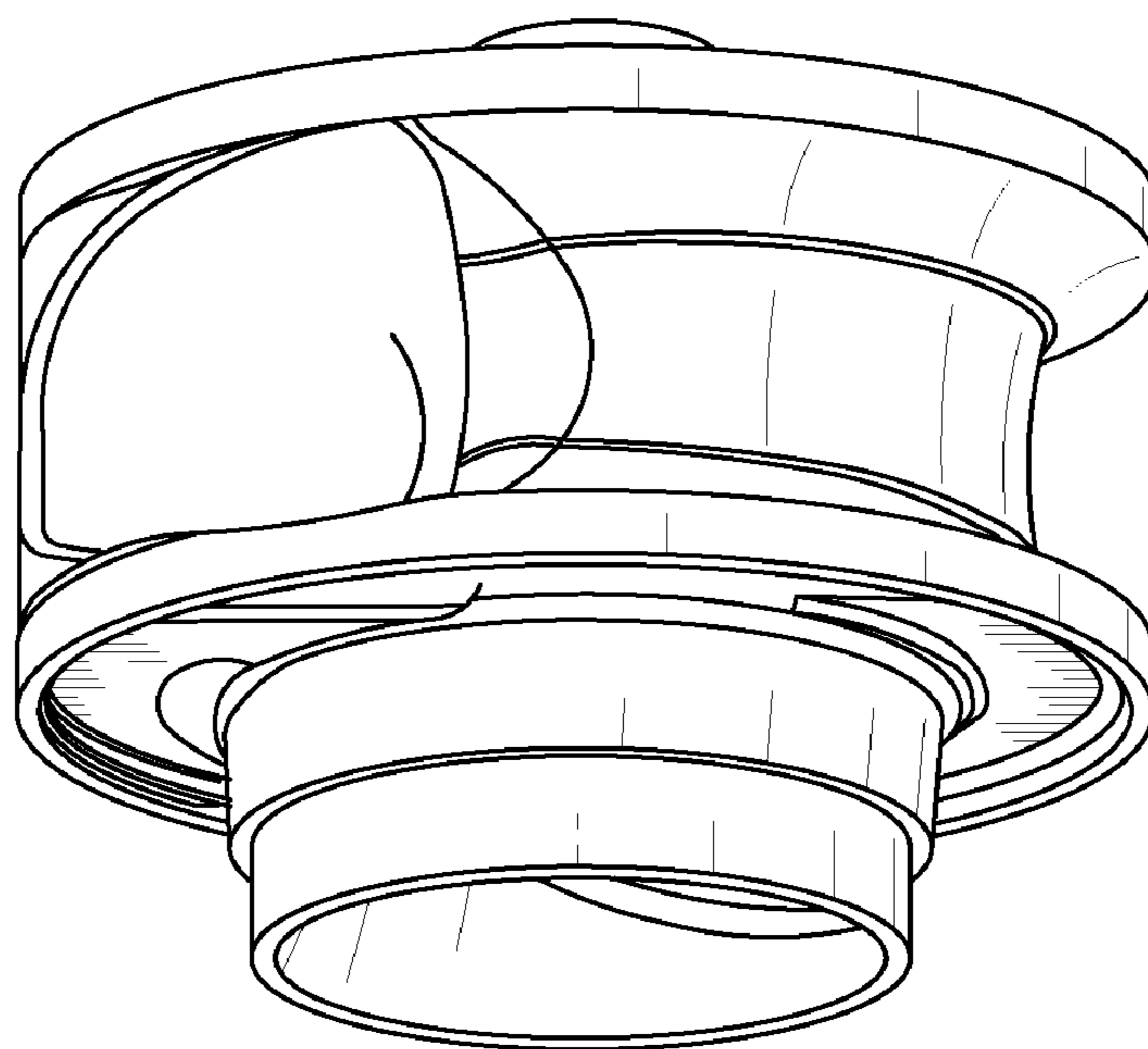

FIG. 2

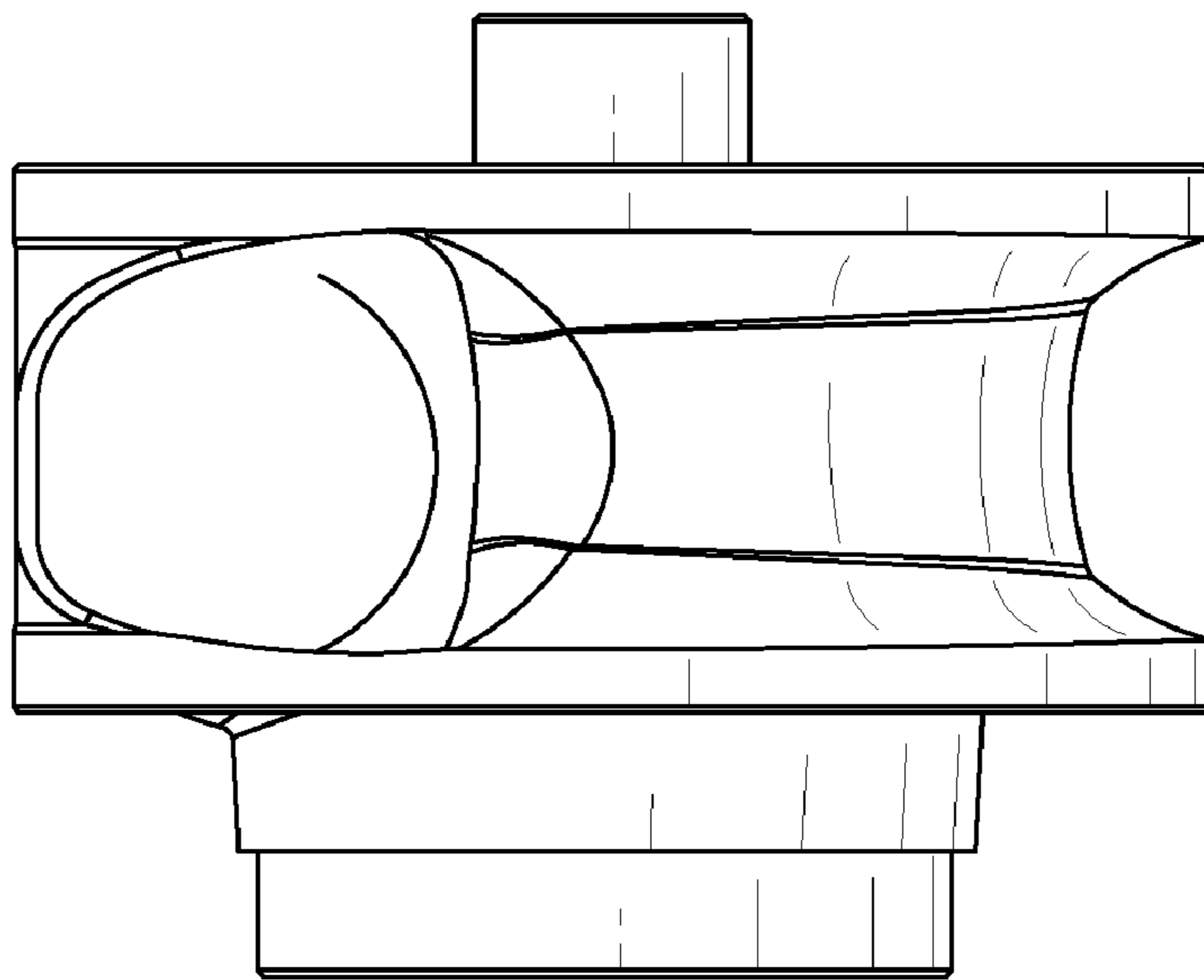

FIG. 3

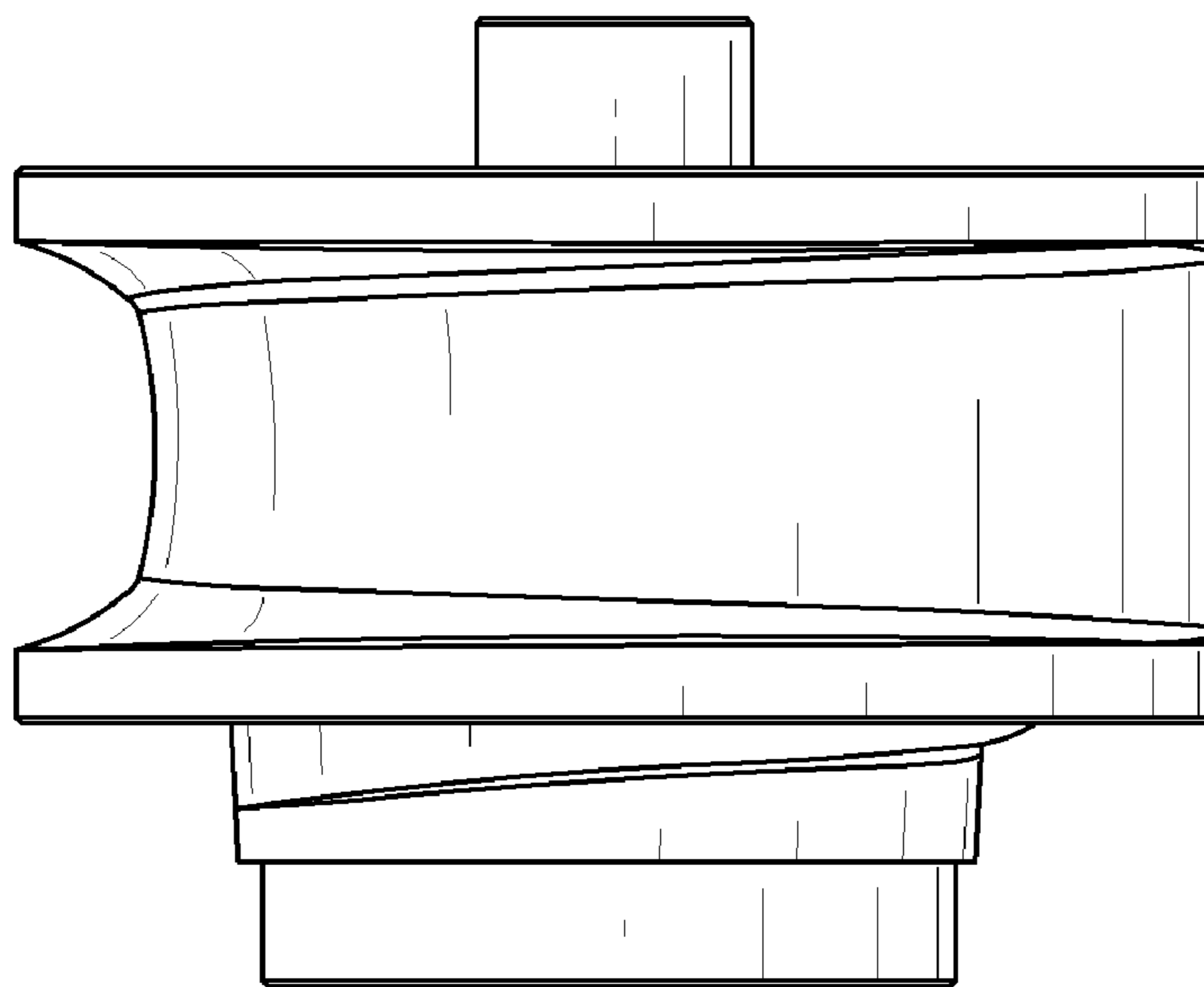

FIG. 4

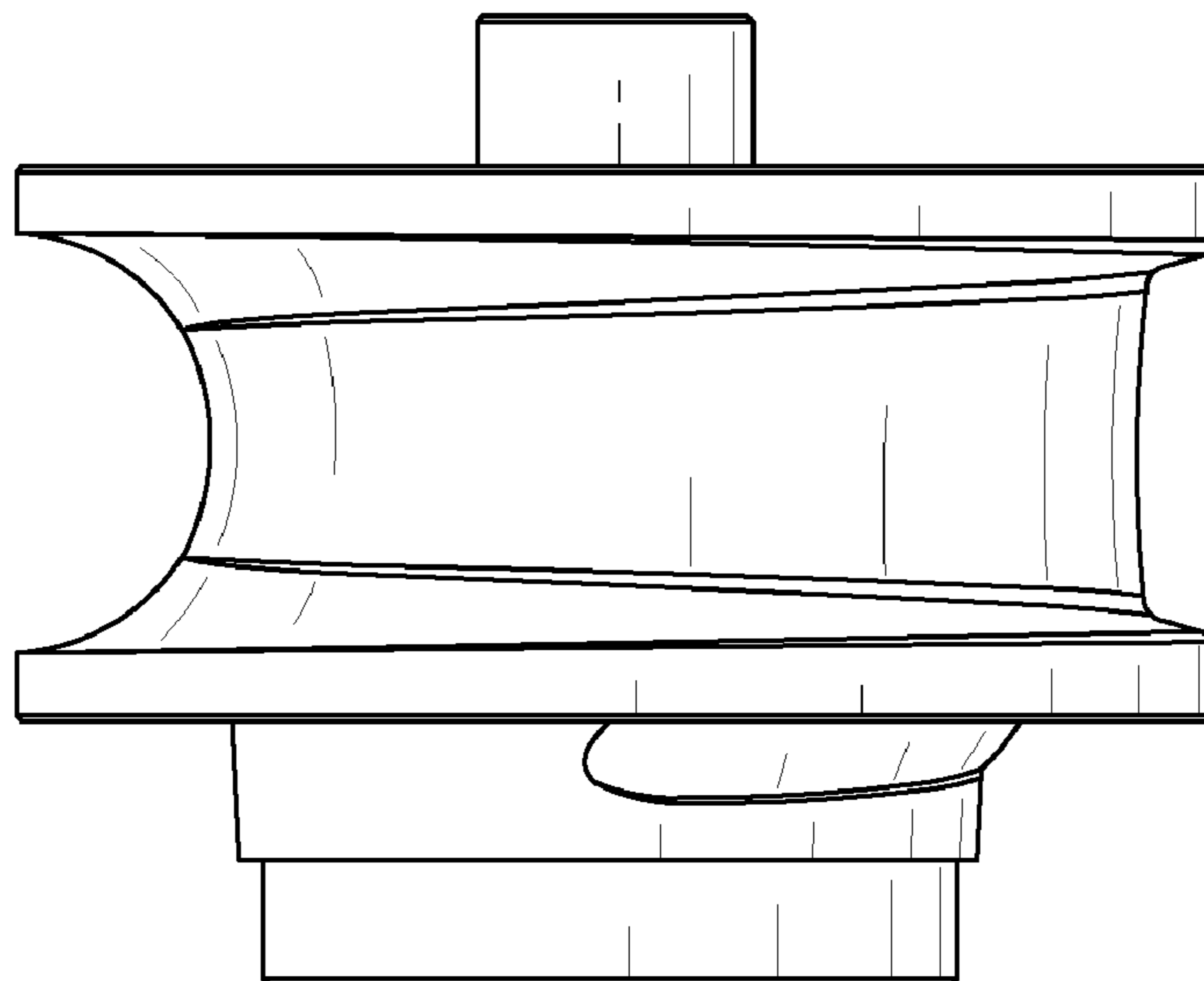

FIG. 5

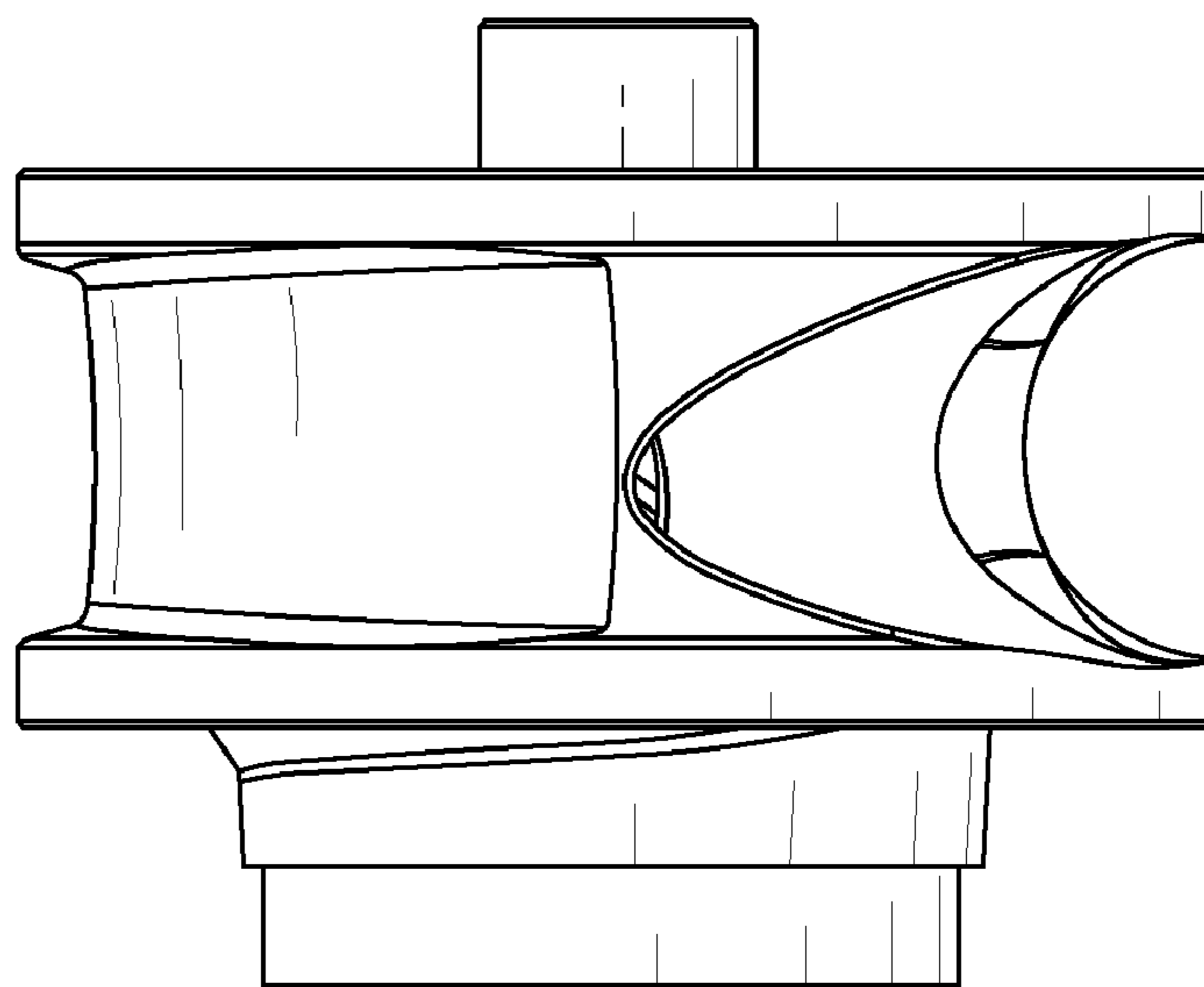

FIG. 6

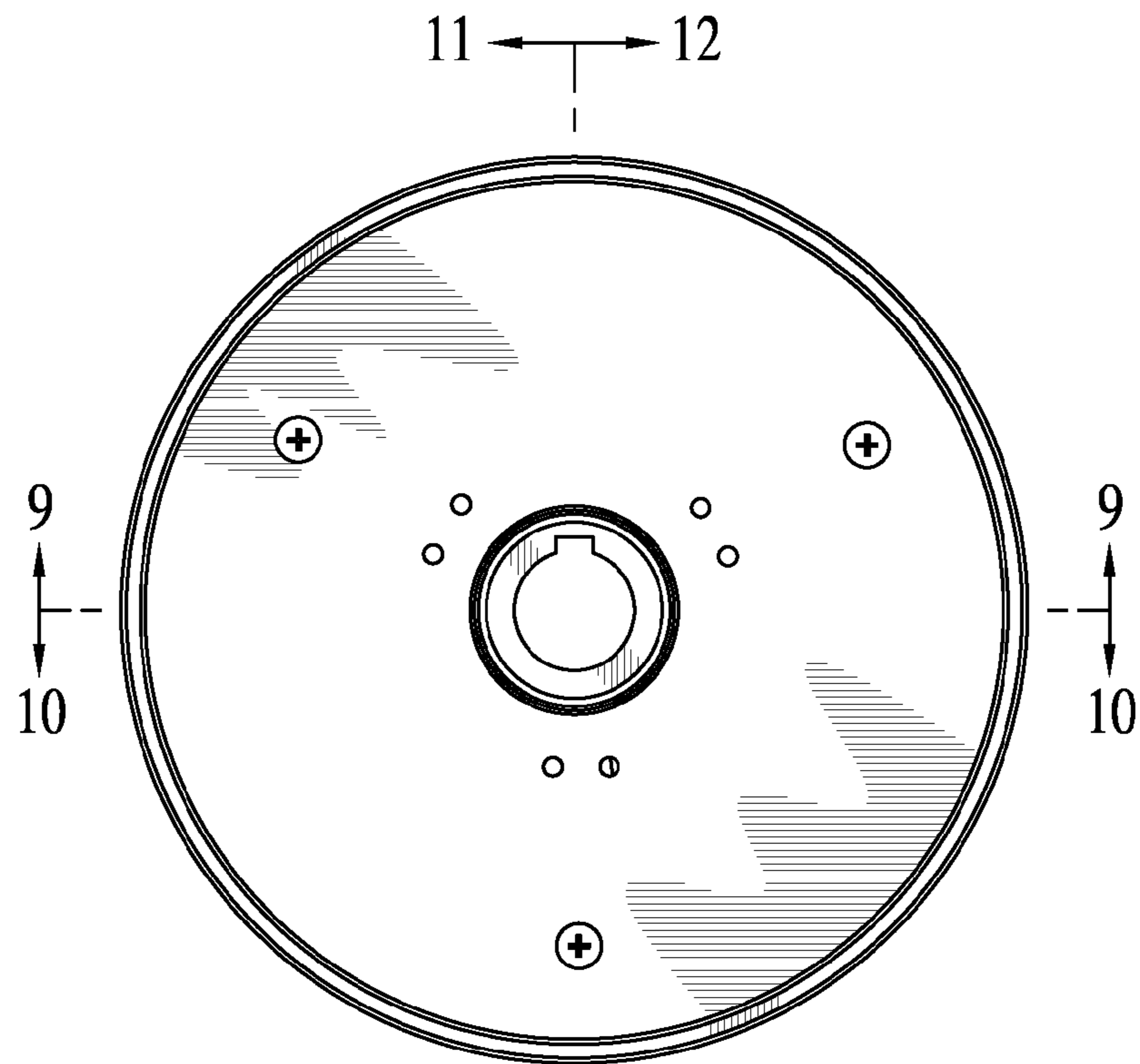

FIG. 7

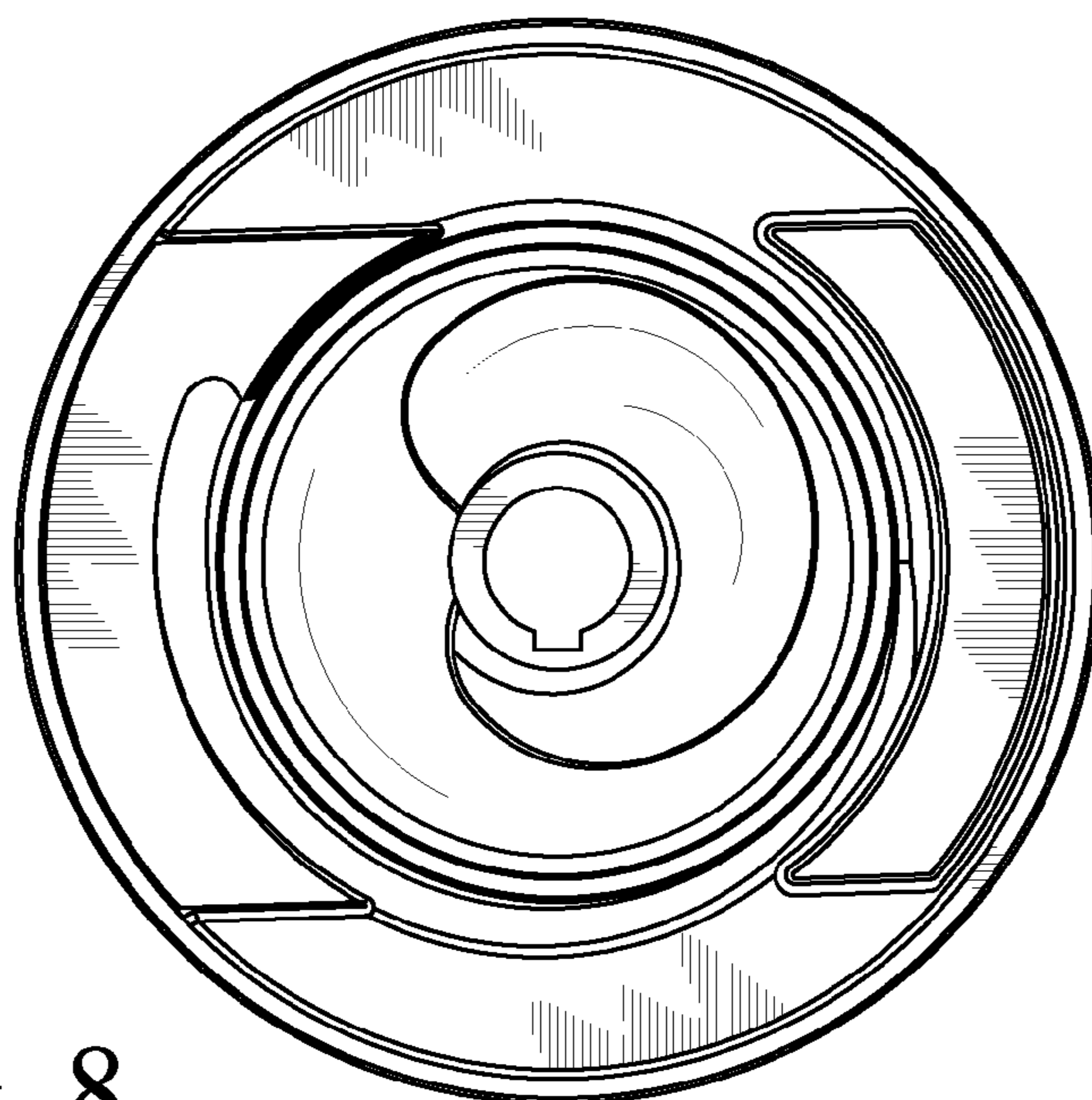
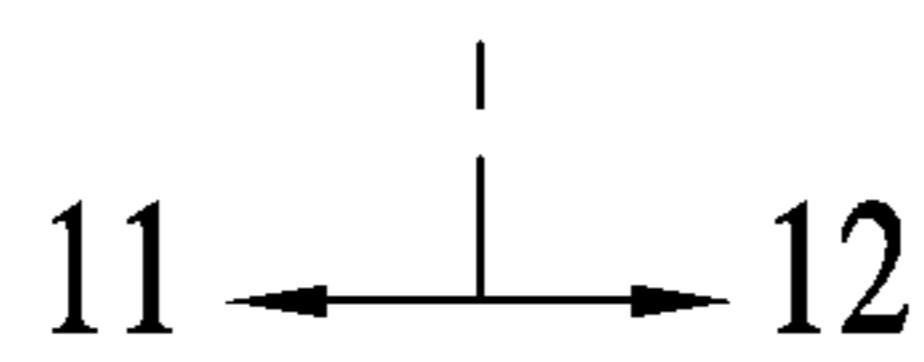

FIG. 8

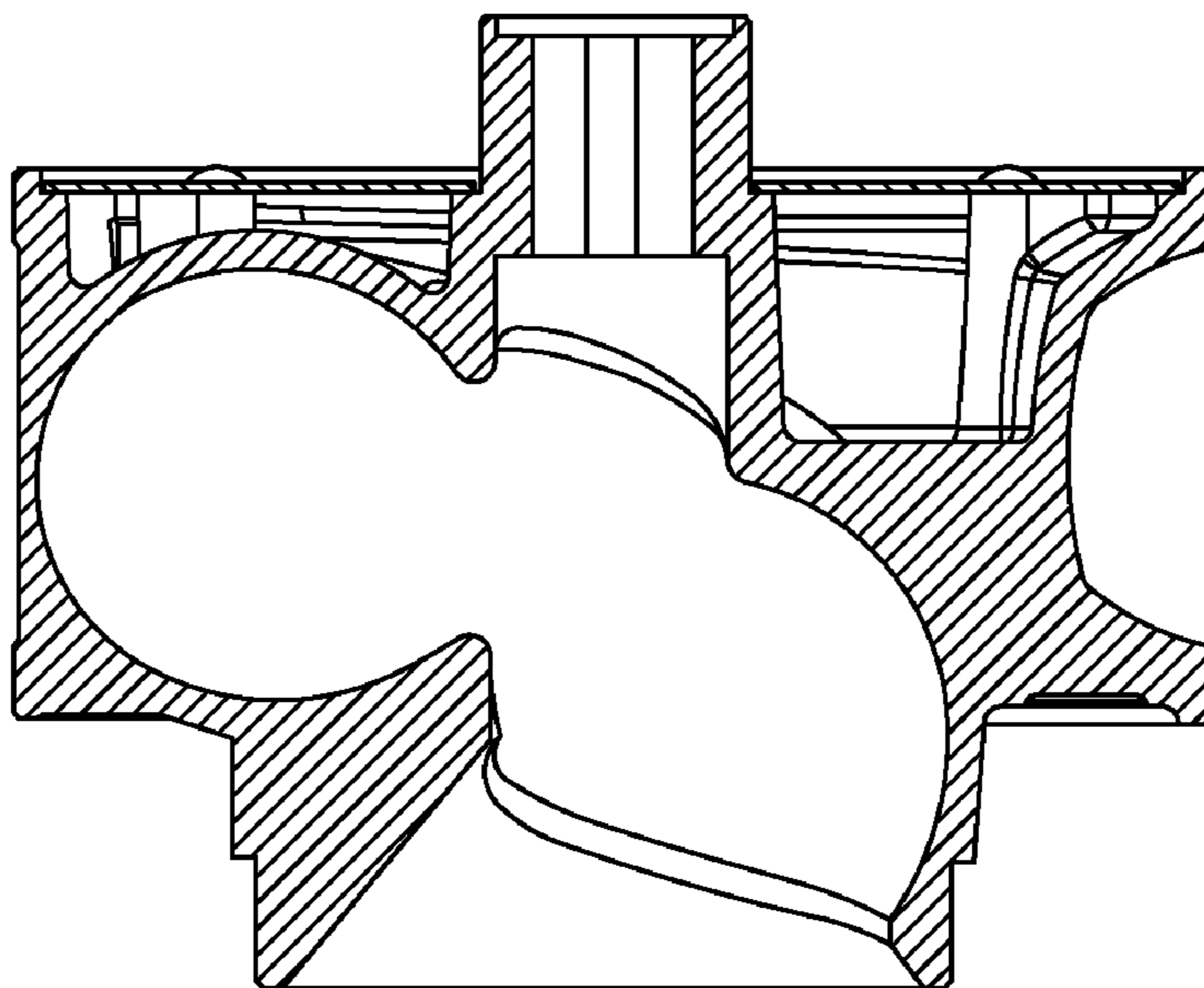

FIG. 9

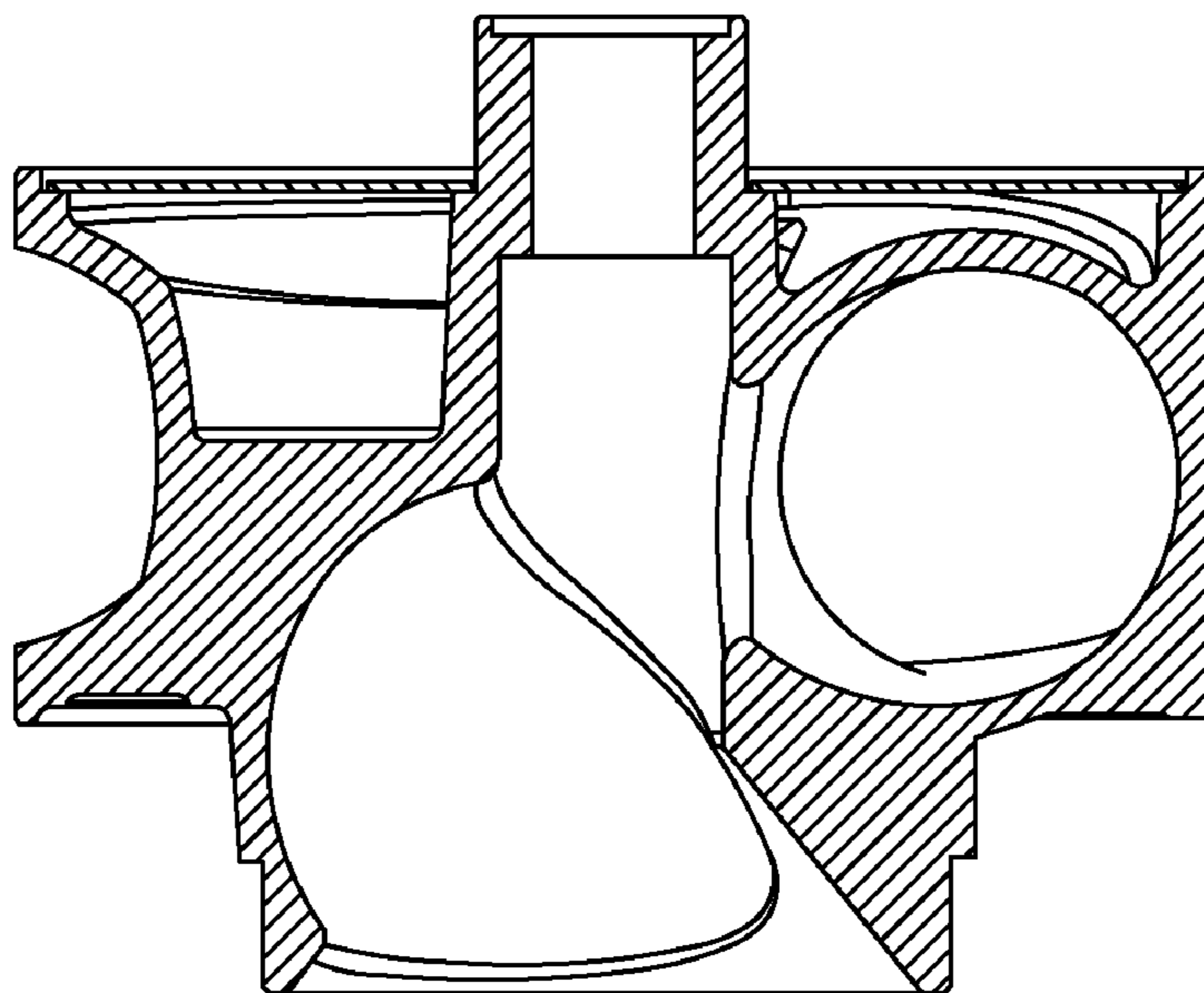

FIG. 10

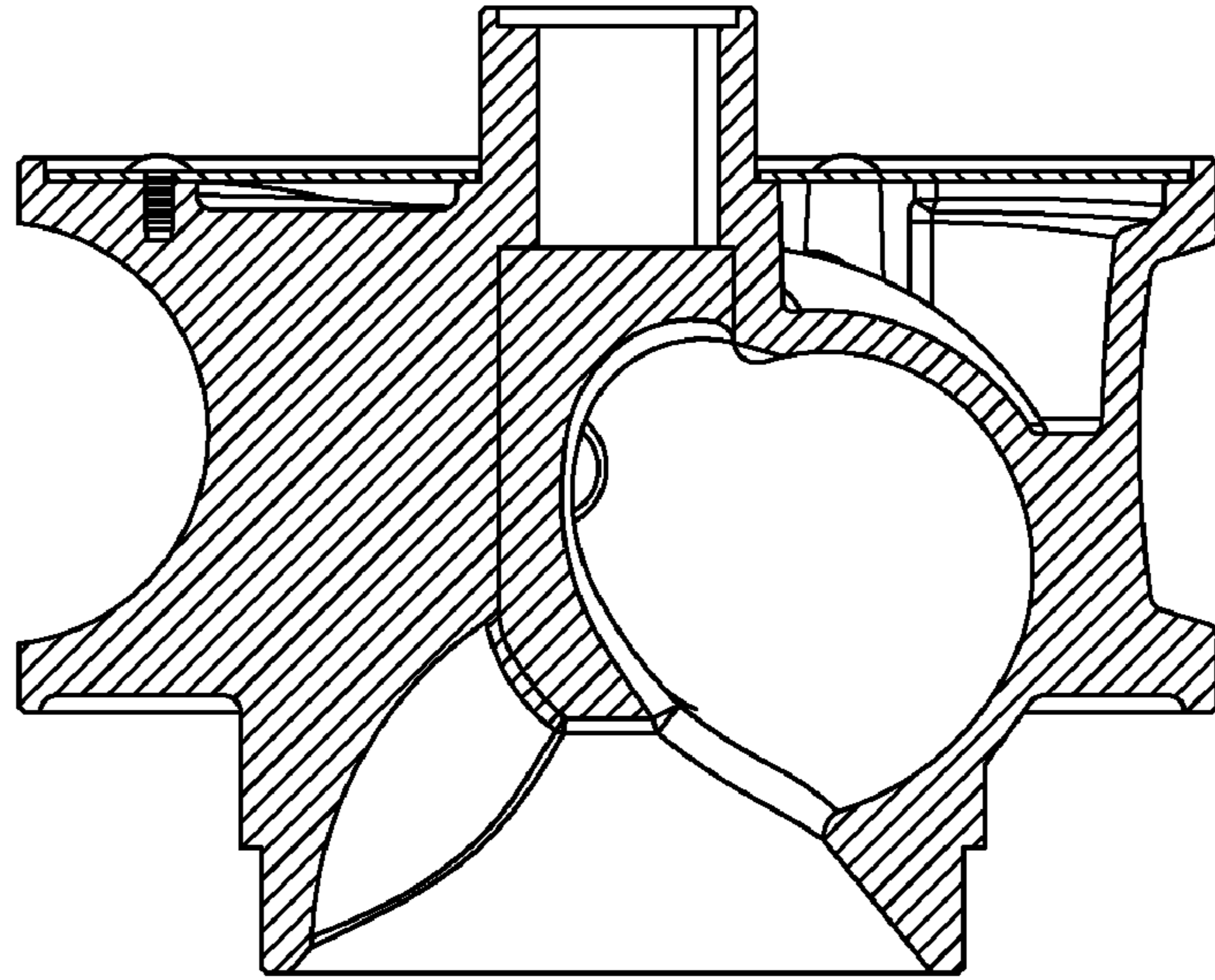

FIG. 11

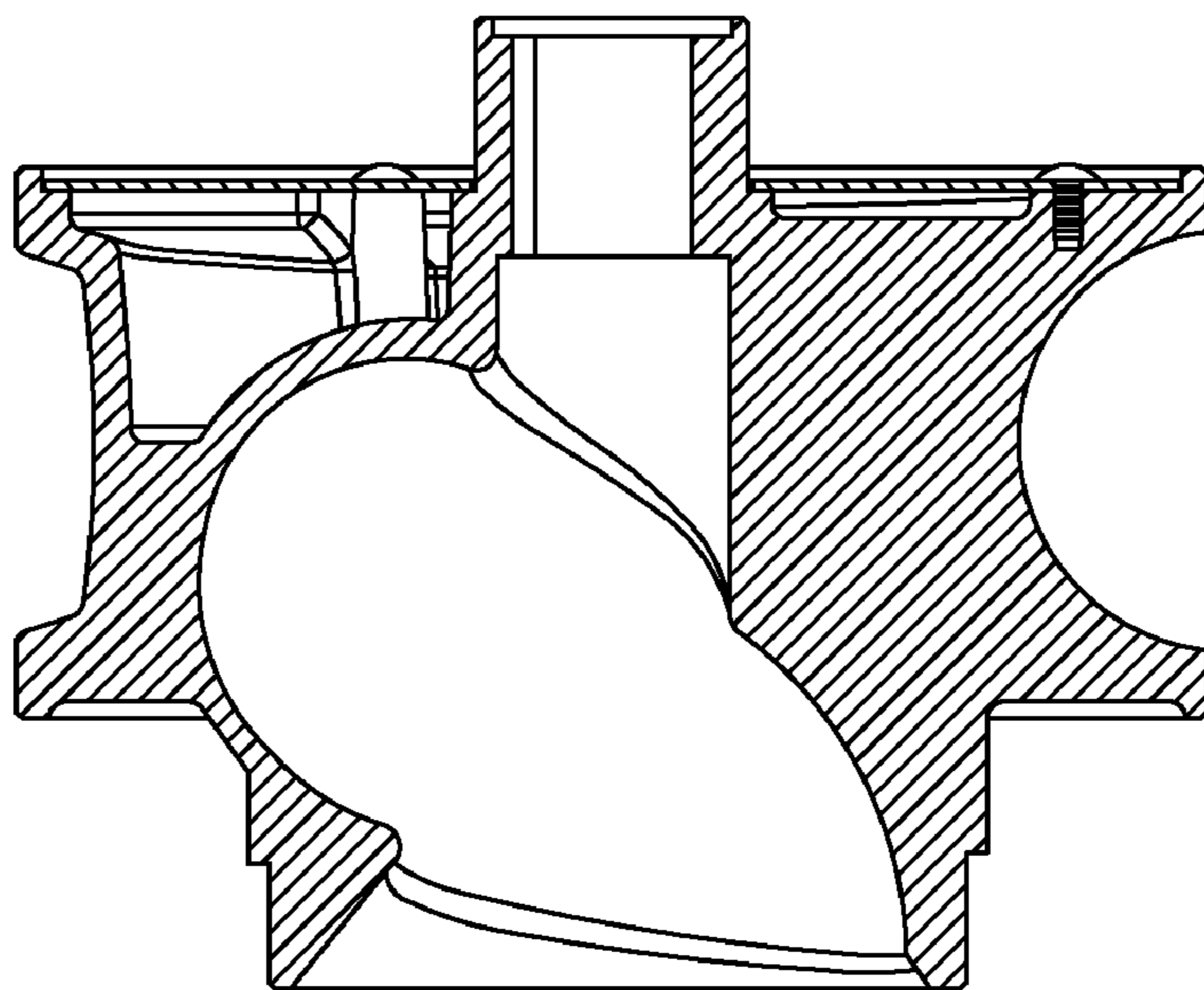

FIG. 12



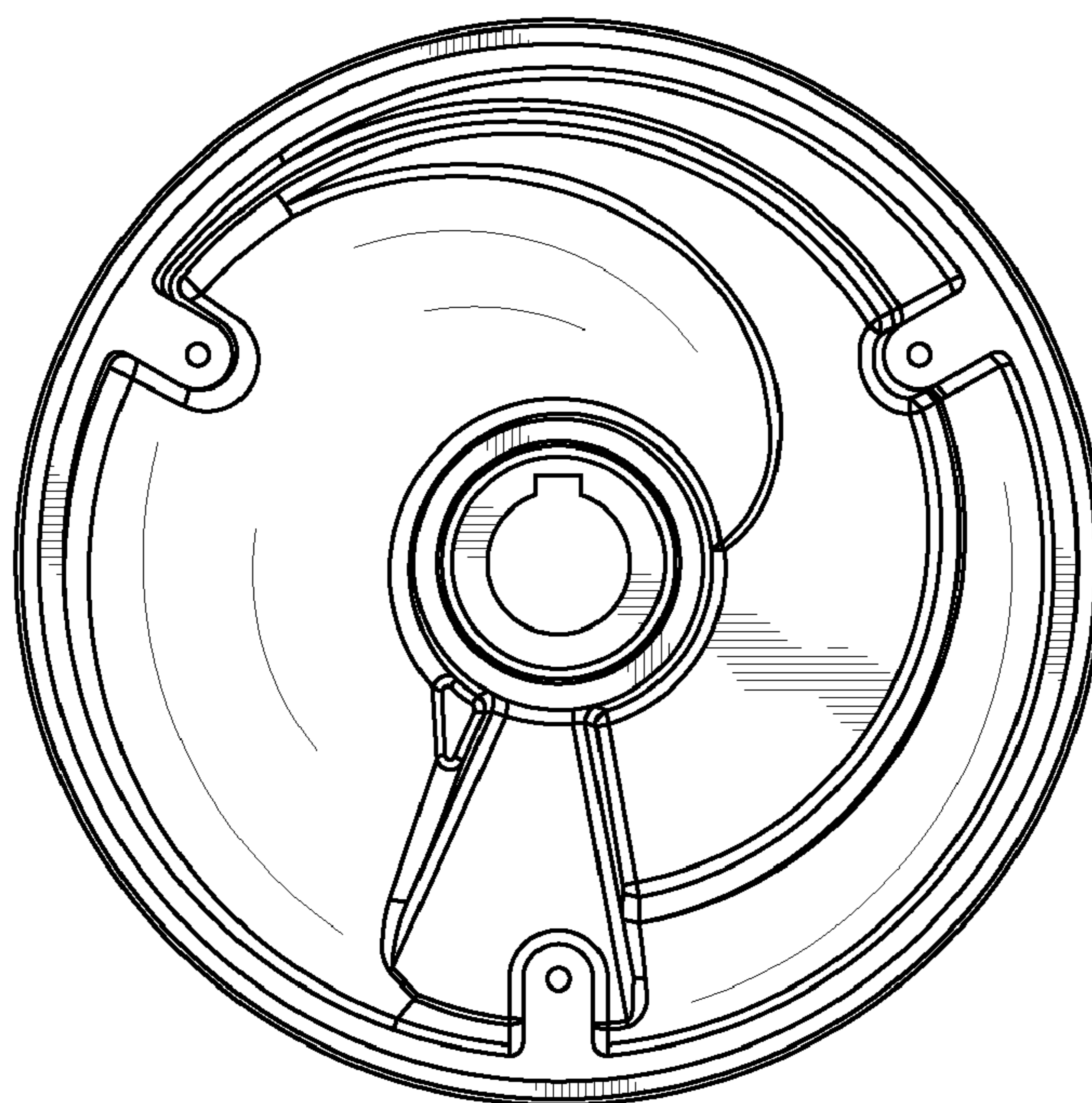

FIG. 13

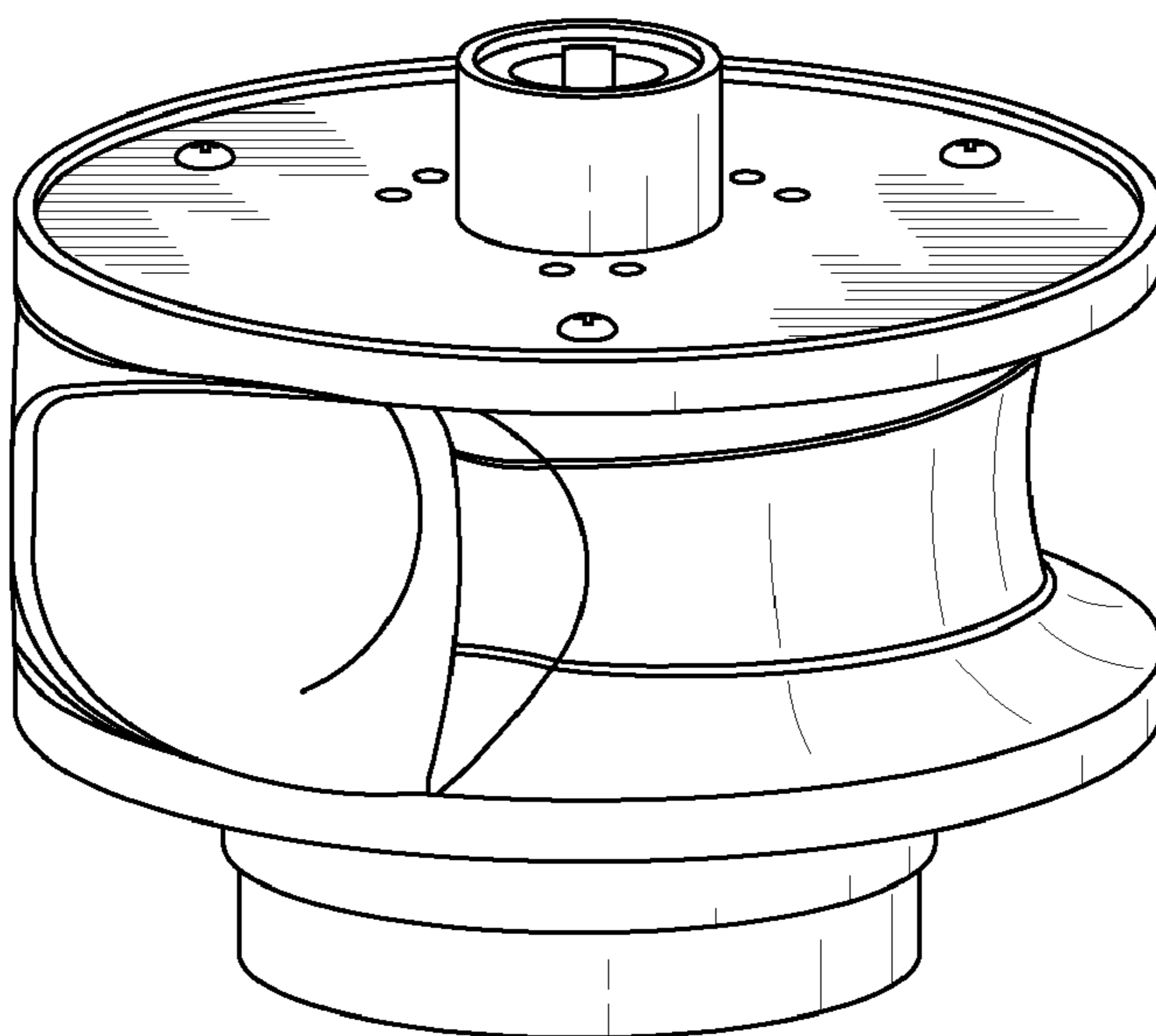

FIG. 14

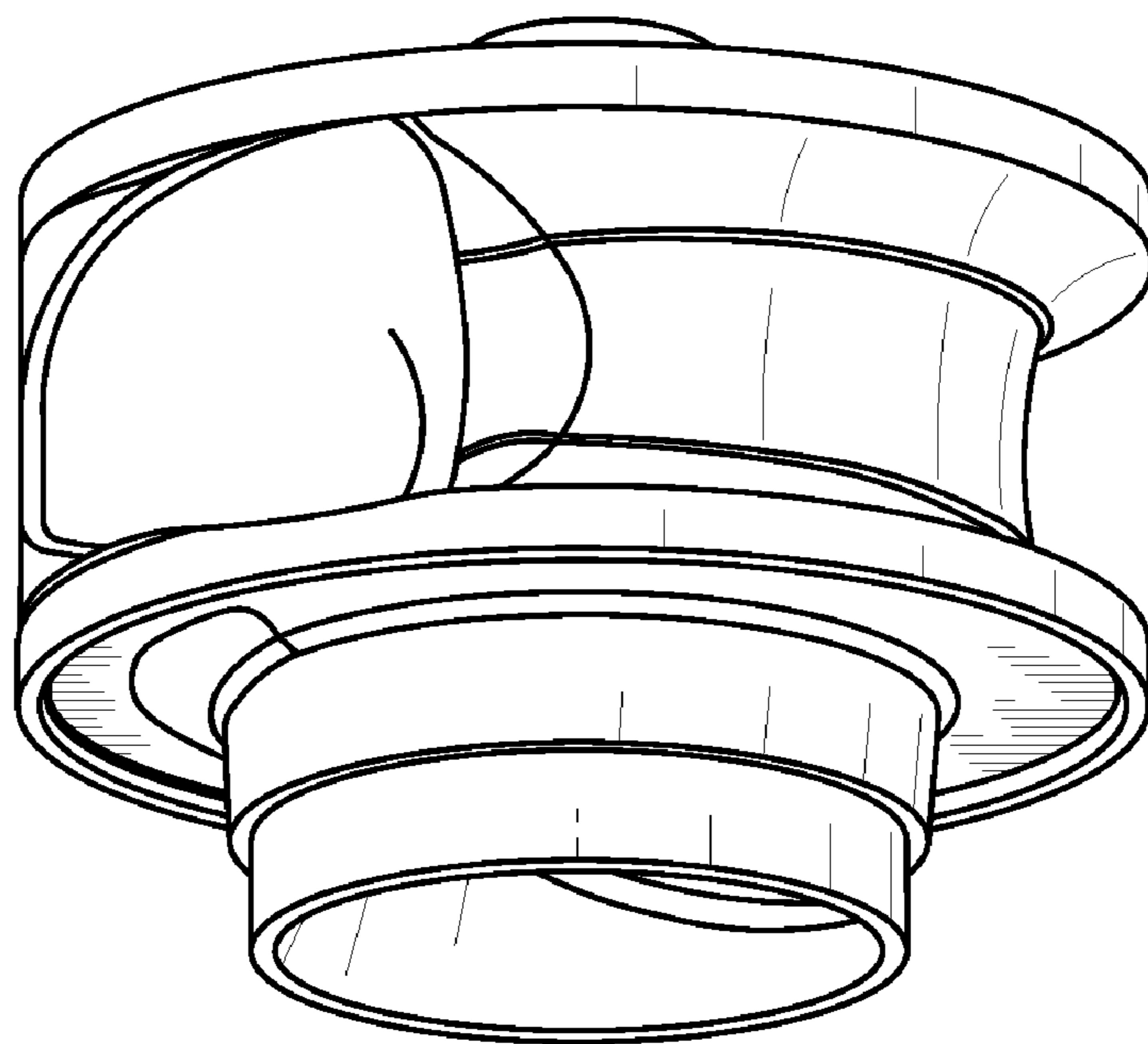

FIG. 15

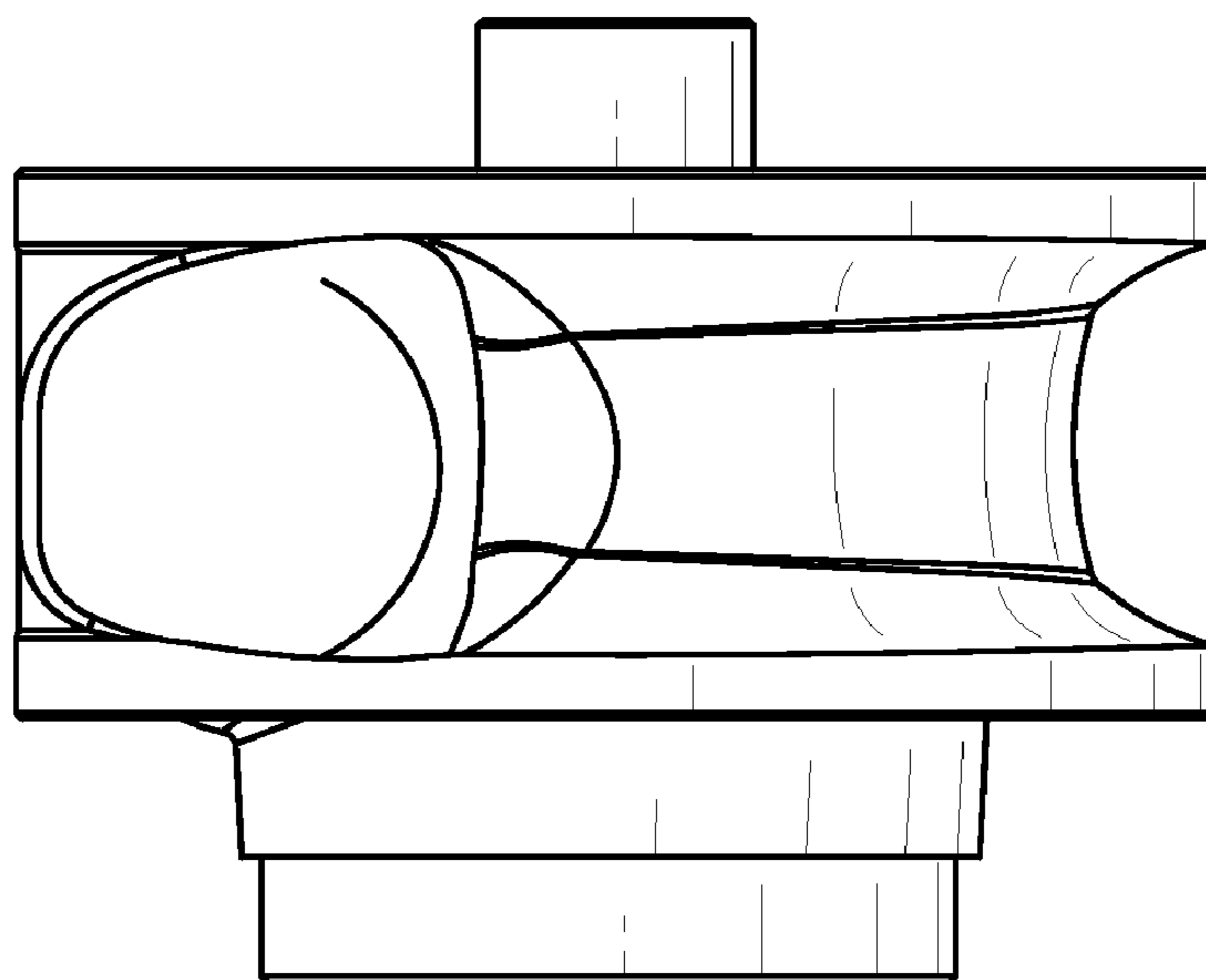

FIG. 16

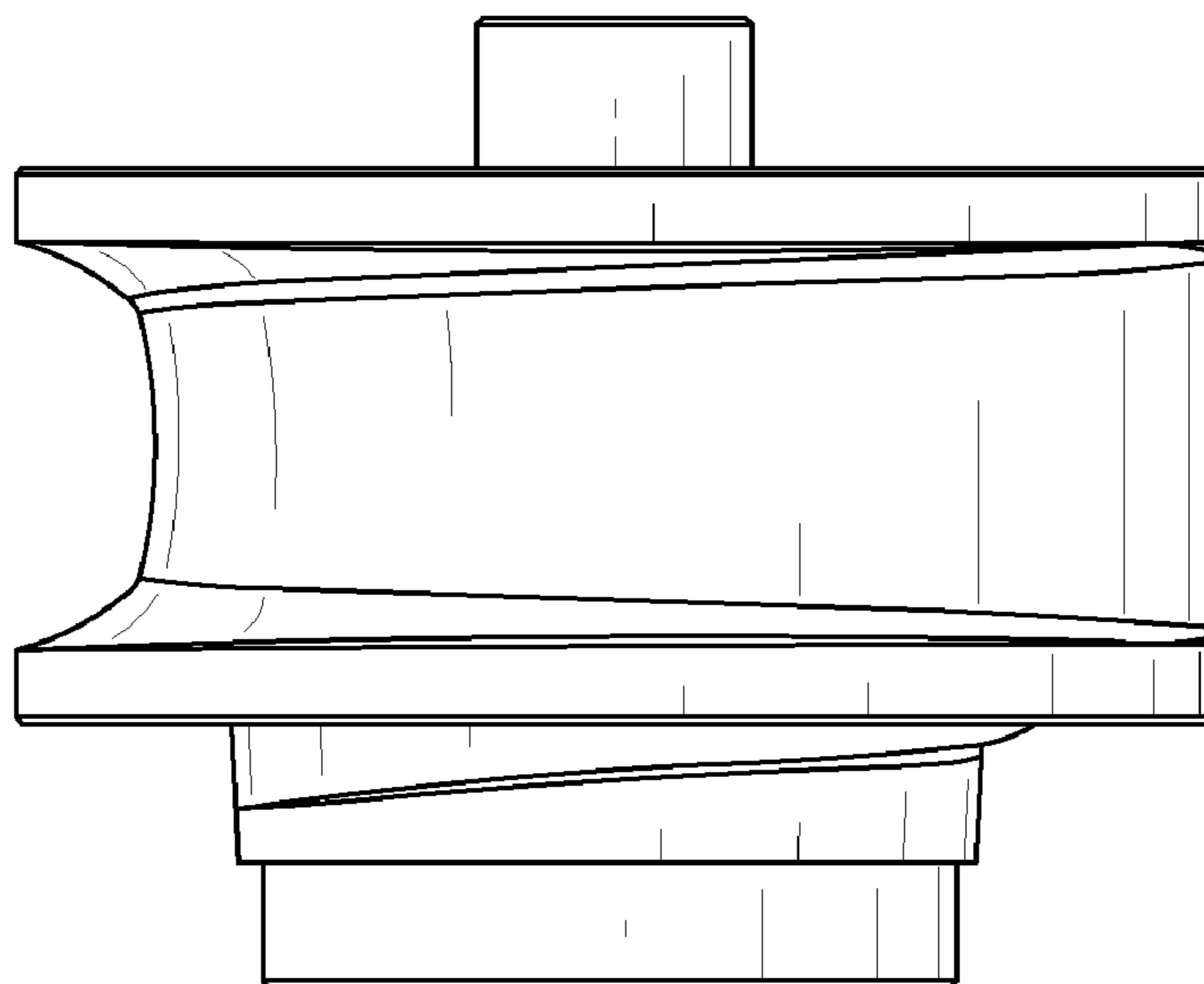

FIG. 17

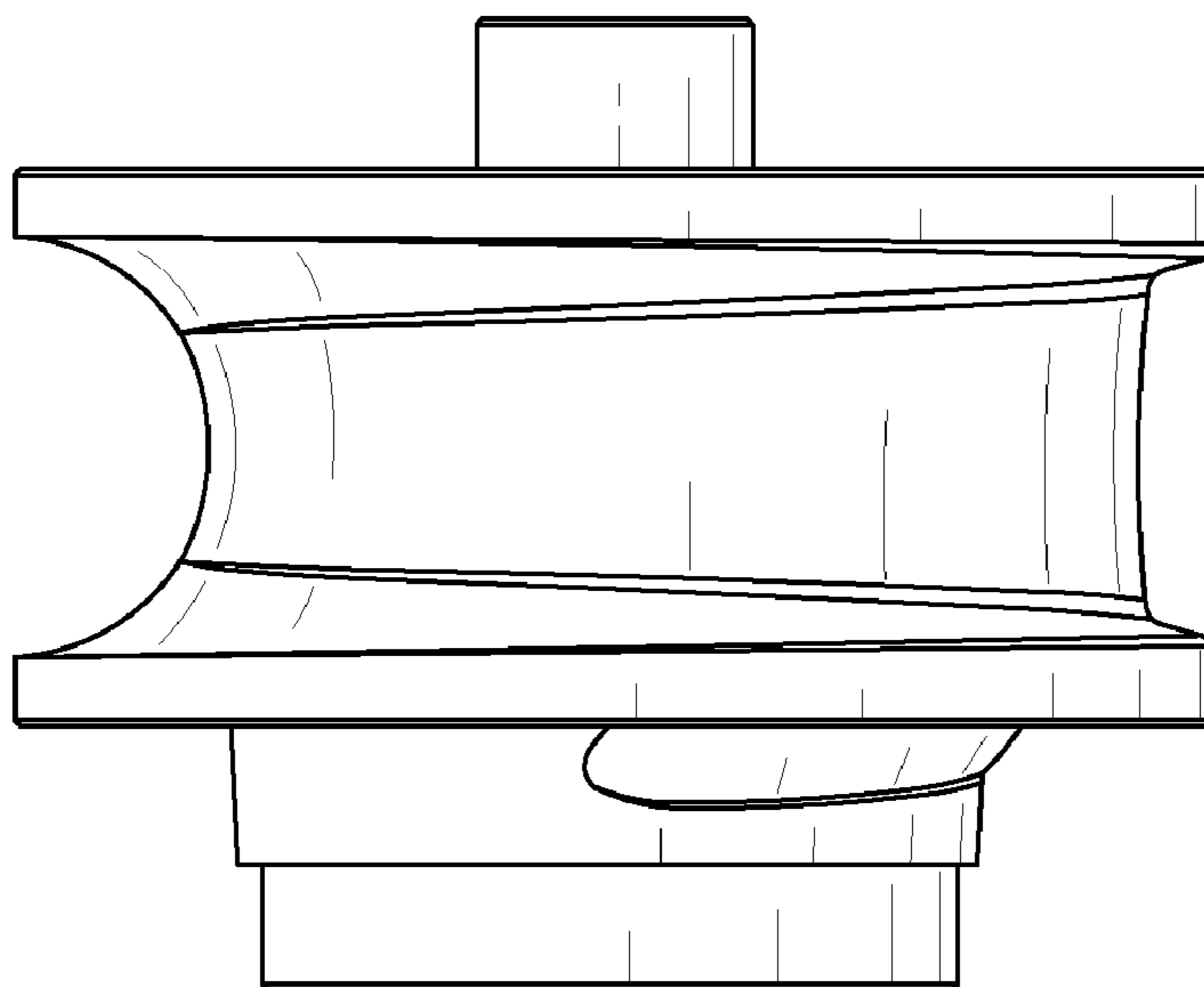

FIG. 18

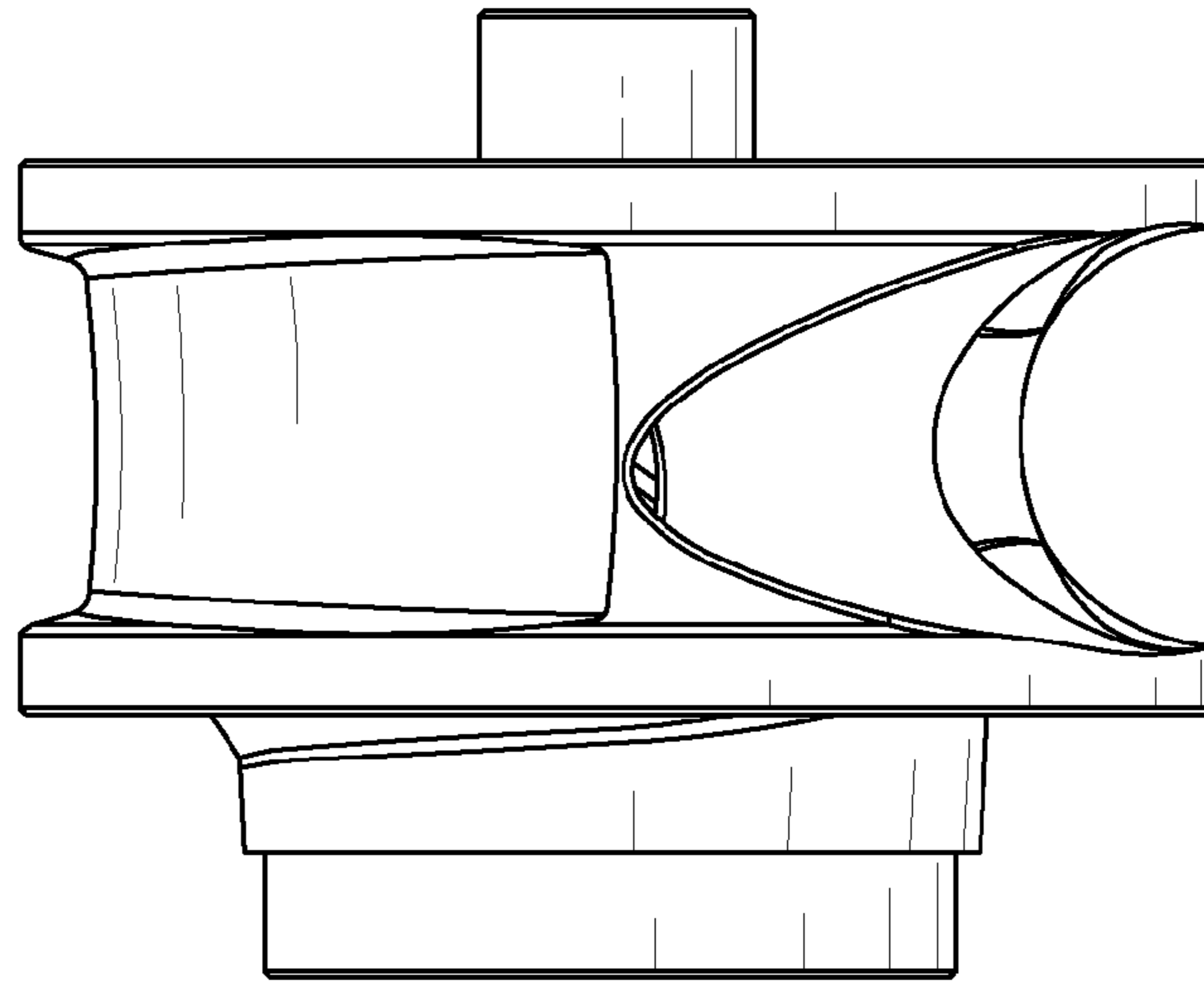

FIG. 19

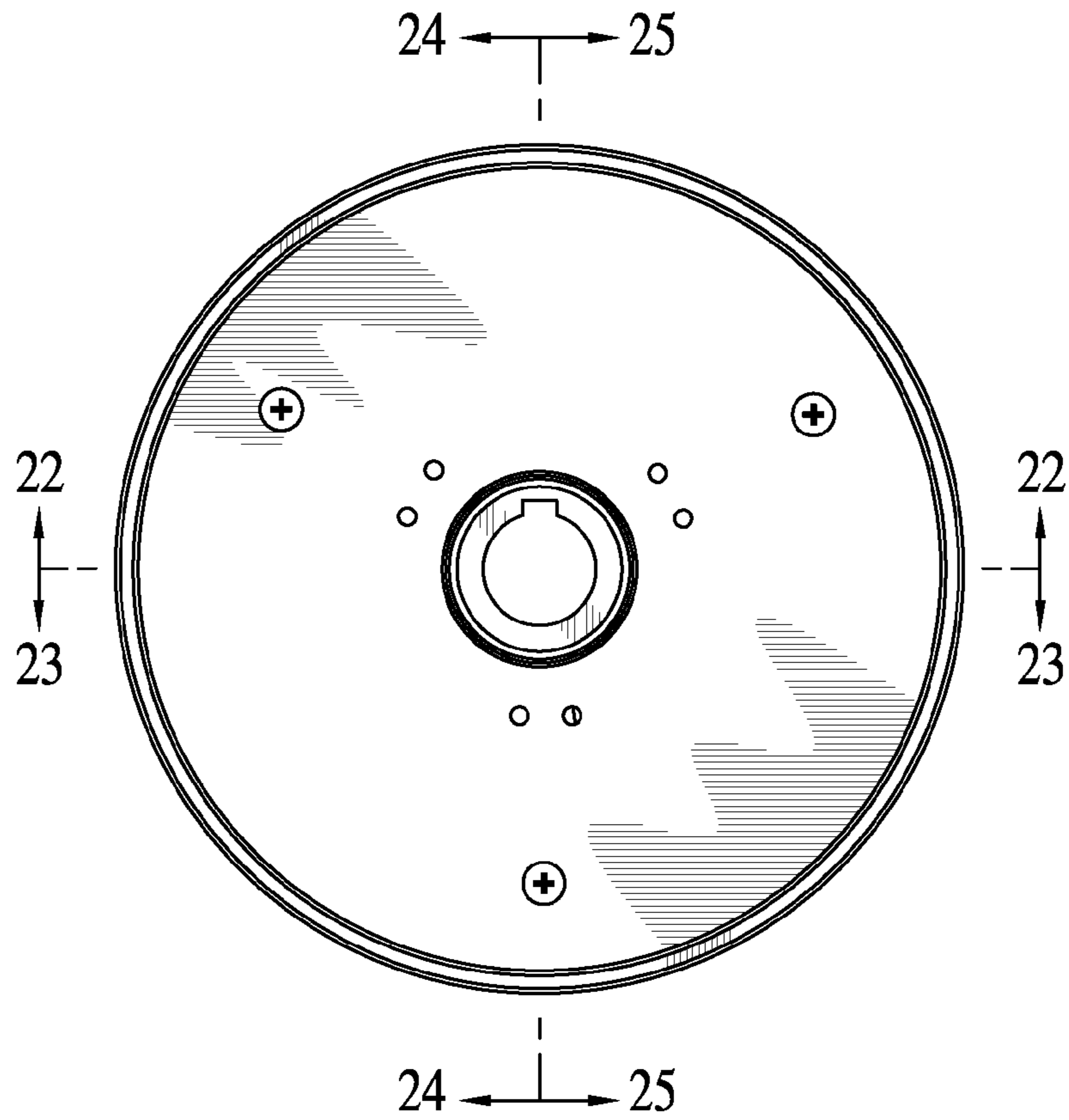

FIG. 20

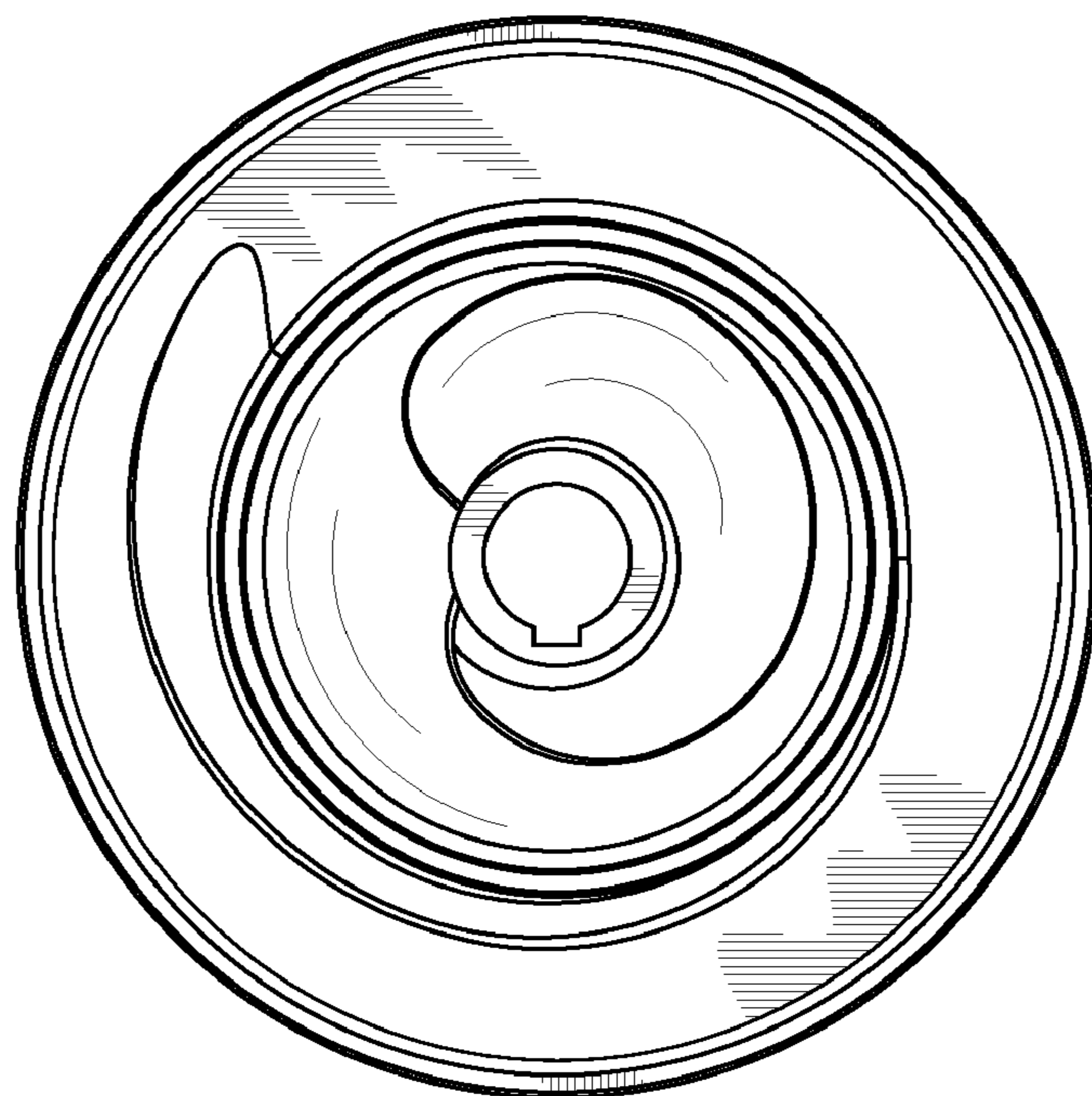

FIG. 21

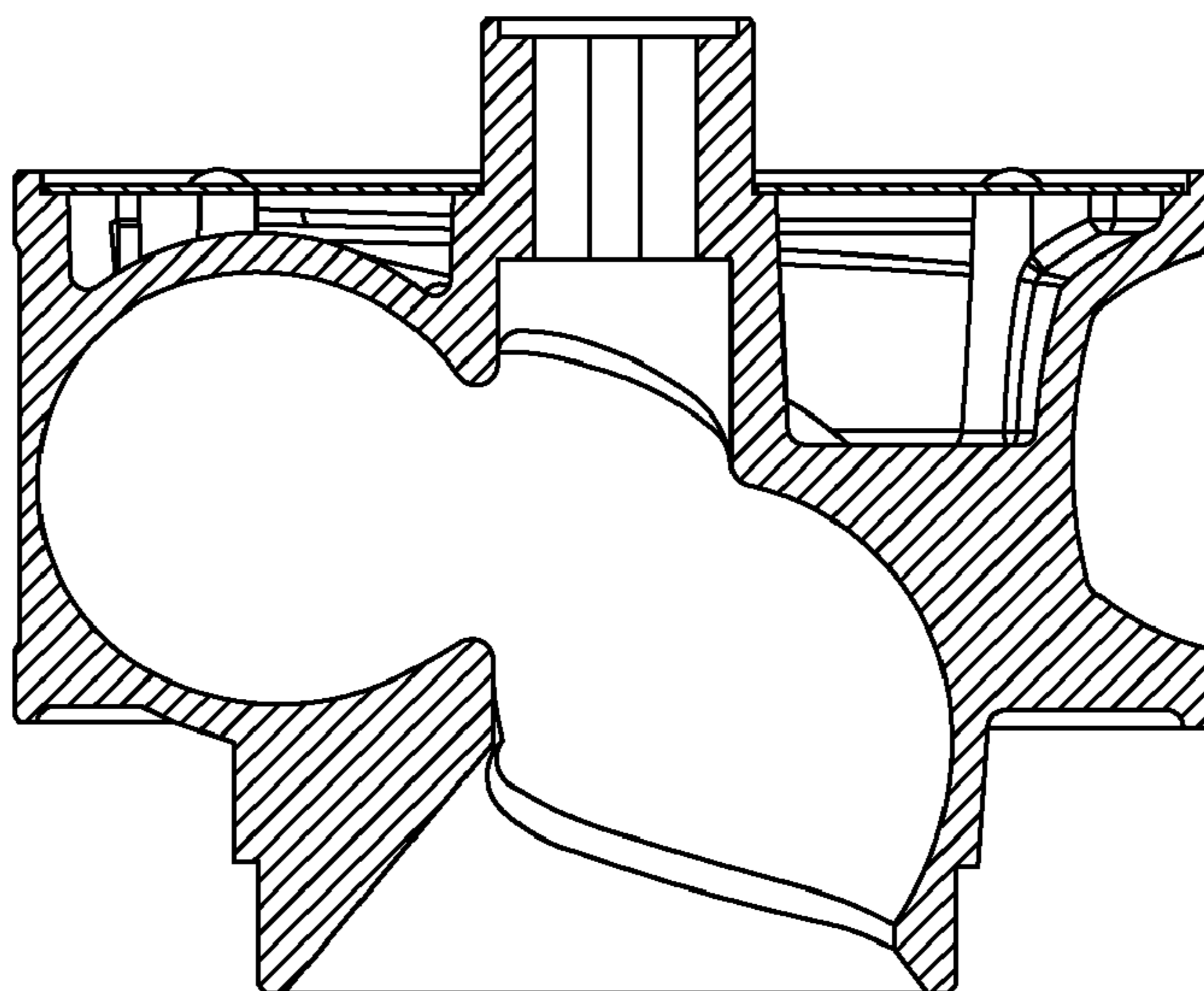

FIG. 22

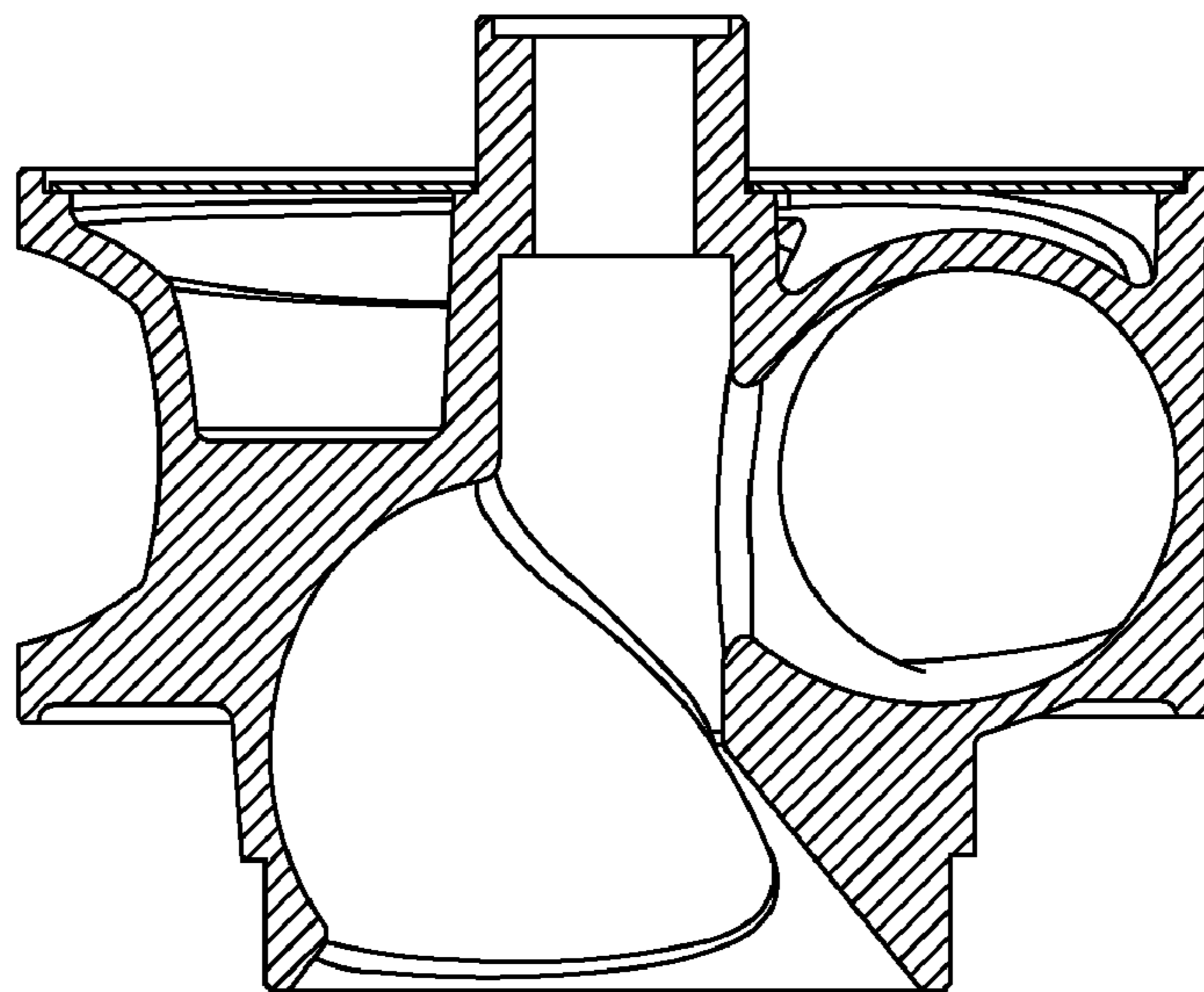

FIG. 23

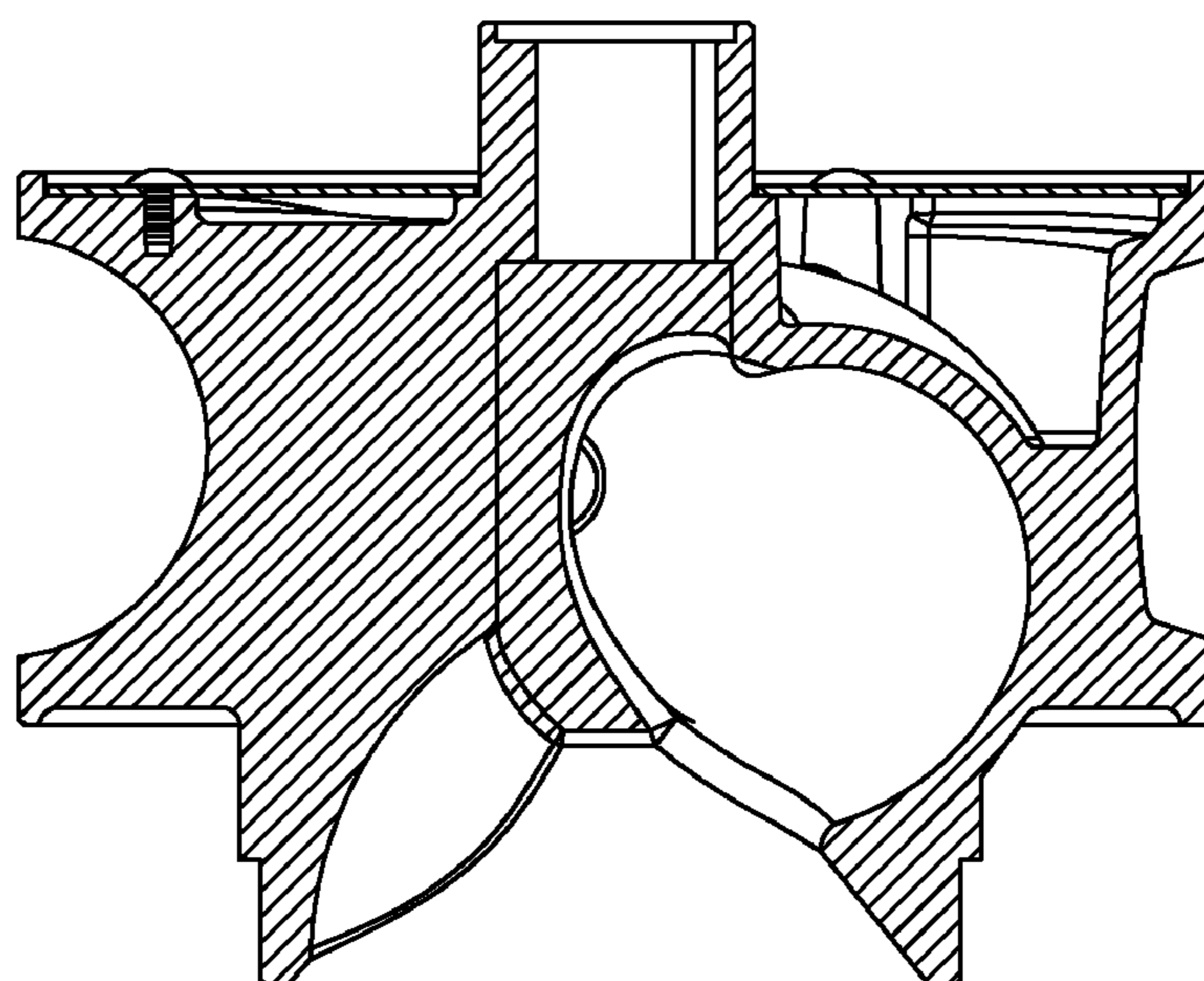

FIG. 24

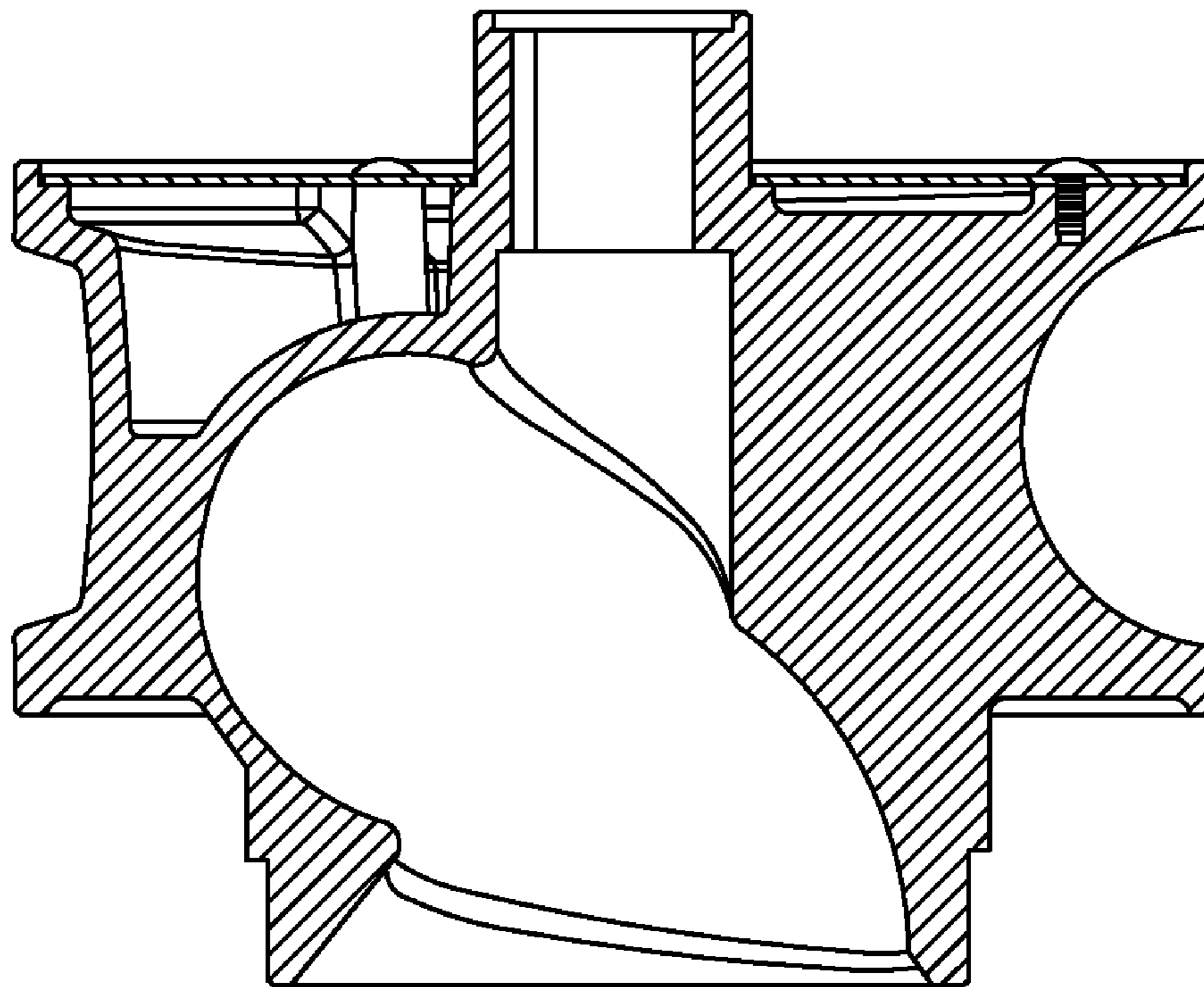

FIG. 25