



US00D607379S

(12) **United States Design Patent**
Inukai et al.

(10) **Patent No.:** **US D607,379 S**
(45) **Date of Patent:** **** Jan. 5, 2010**

(54) **AUTOMOBILE AND TOY REPLICA THEREOF**

(75) Inventors: **Kenichi Inukai**, Toyota (JP); **Manabu Hirokawa**, Toyota (JP); **Tomokazu Morikawa**, Kariya (JP); **Takafumi Ito**, Kariya (JP); **Kazumi Kouwaki**, Kariya (JP); **Ryousuke Yokoi**, Kariya (JP); **Takeo Sowa**, Kariya (JP)

(73) Assignee: **Toyota Jidosha Kabushiki Kaisha**, Toyota (JP)

(**) Term: **14 Years**

(21) Appl. No.: **29/329,717**

(22) Filed: **Dec. 19, 2008**

(51) **LOC (9) Cl.** **12-08**

(52) **U.S. Cl.** **D12/92**

(58) **Field of Classification Search** D12/86,
D12/90-92; 296/181.1, 181.5

See application file for complete search history.

(56) **References Cited**

U.S. PATENT DOCUMENTS

D501,645 S	2/2005	Hosoda et al.	
D531,547 S	11/2006	Hiruta et al.	
D547,699 S	7/2007	Okazak et al.	
D562,188 S	2/2008	Matsumoto et al.	
D567,147 S	4/2008	Sakae et al.	
D573,064 S *	7/2008	Sawai	D12/92
D596,991 S *	7/2009	Takahashi	D12/92

OTHER PUBLICATIONS

Driver Jul. 5th Issue, Mazda MPV, Issued on Jul. 5, 2008, Yaesu Publishing Co., Ltd.

Toyota Corolla Rumion, Brochure of Rumion, Oct. 2007, Toyota Jidosha Kabushiki Kaisha.

Mazda Biante, The separate volume of Motar Fan All About Minivans, issued Aug. 24, 2008, Sanei-Shobo Publishing Co., Ltd. Honda Accord, <http://www.netcarshow.com/honda/2008-accord-lx-p-sedan>.

Mazda 6, <http://www.netcarshow.com/mazda/2008-6-sedan>.

Brochure of Belta, Toyota Belta, Nov. 2005, Toyota Jidosha Kabushiki Kaisha.

Automobile Guidebook of Japan, Toyota Mark X, issued on Oct. 24, 2007 by Japan Automobile Manufacturers Association, Inc.

* cited by examiner

Primary Examiner—Melody N Brown

(74) *Attorney, Agent, or Firm*—Finnegan, Henderson, Farabow, Garrett & Dunner, LLP

(57) **CLAIM**

The ornamental design for an automobile and toy replica thereof, as shown and described.

DESCRIPTION

FIG. 1 is a front perspective view of an automobile and toy replica thereof of our new design;

FIG. 2 is a right side view thereof, the left side view being a mirror image thereof, with the exception of the fuel door which is not present on the left side;

FIG. 3 is a rear perspective view thereof;

FIG. 4 is a front view thereof;

FIG. 5 is a rear view thereof; and,

FIG. 6 is a top plan view thereof.

The bottom view of the automobile forms no part of the claimed design.

1 Claim, 5 Drawing Sheets

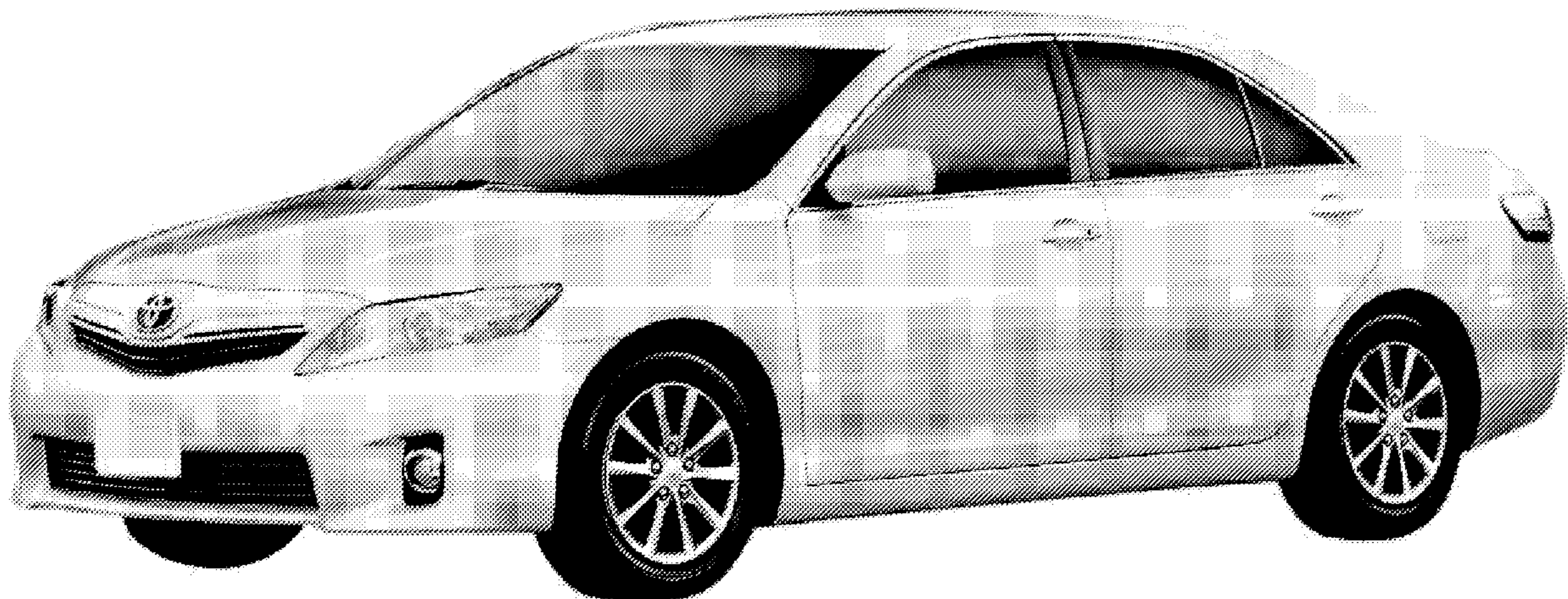

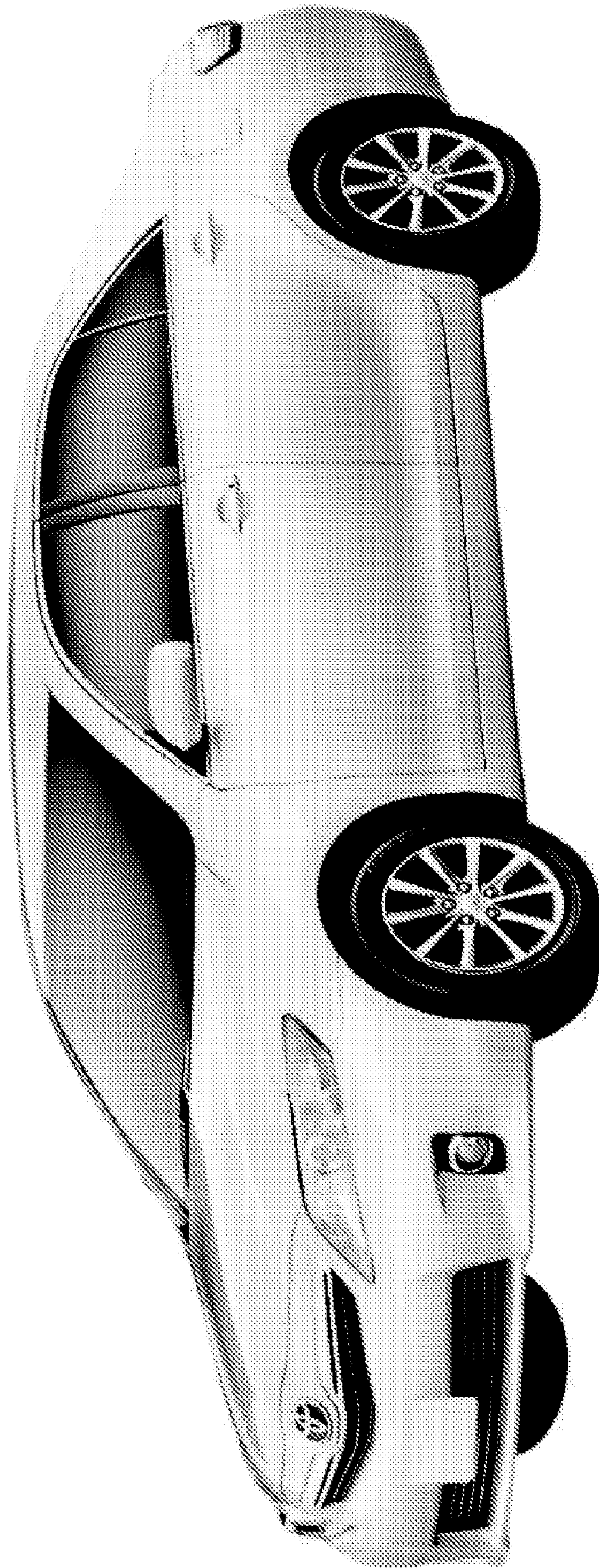

FIG. 1

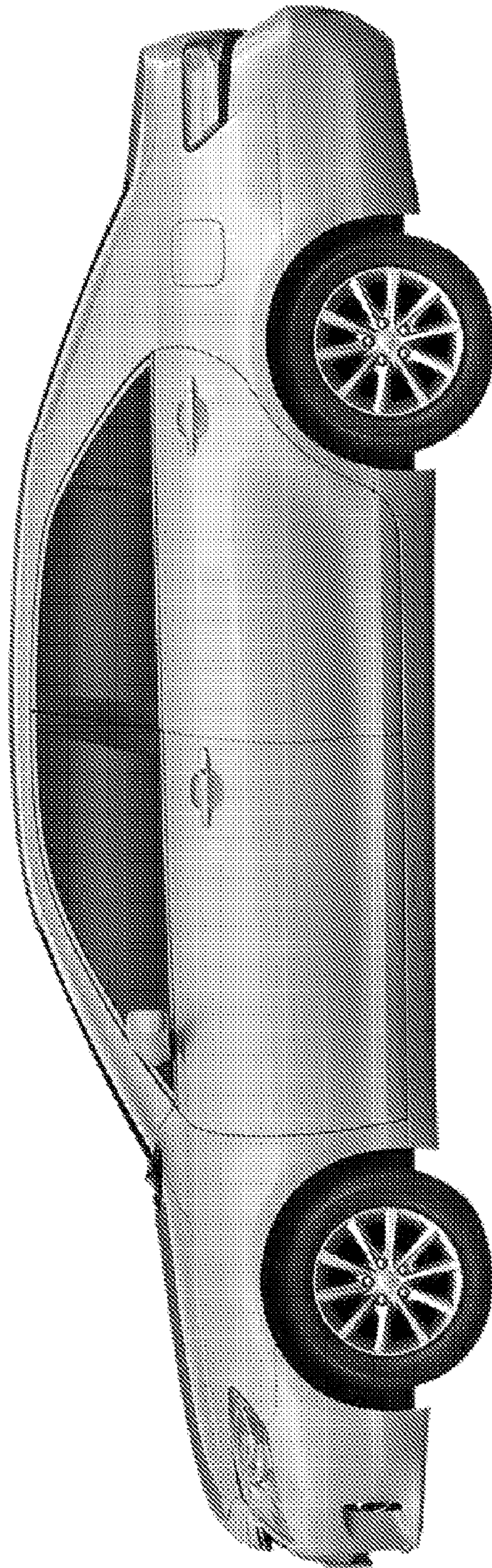

FIG. 2

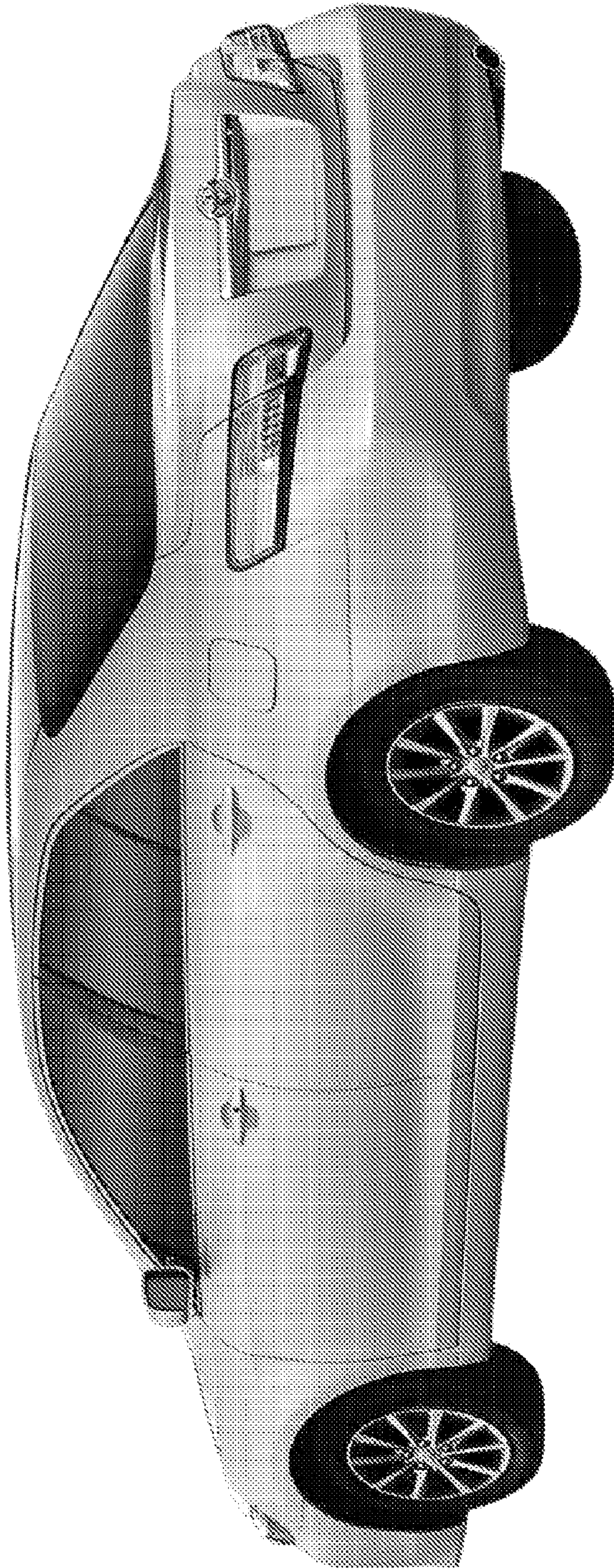

FIG. 3



FIG. 4



FIG. 5

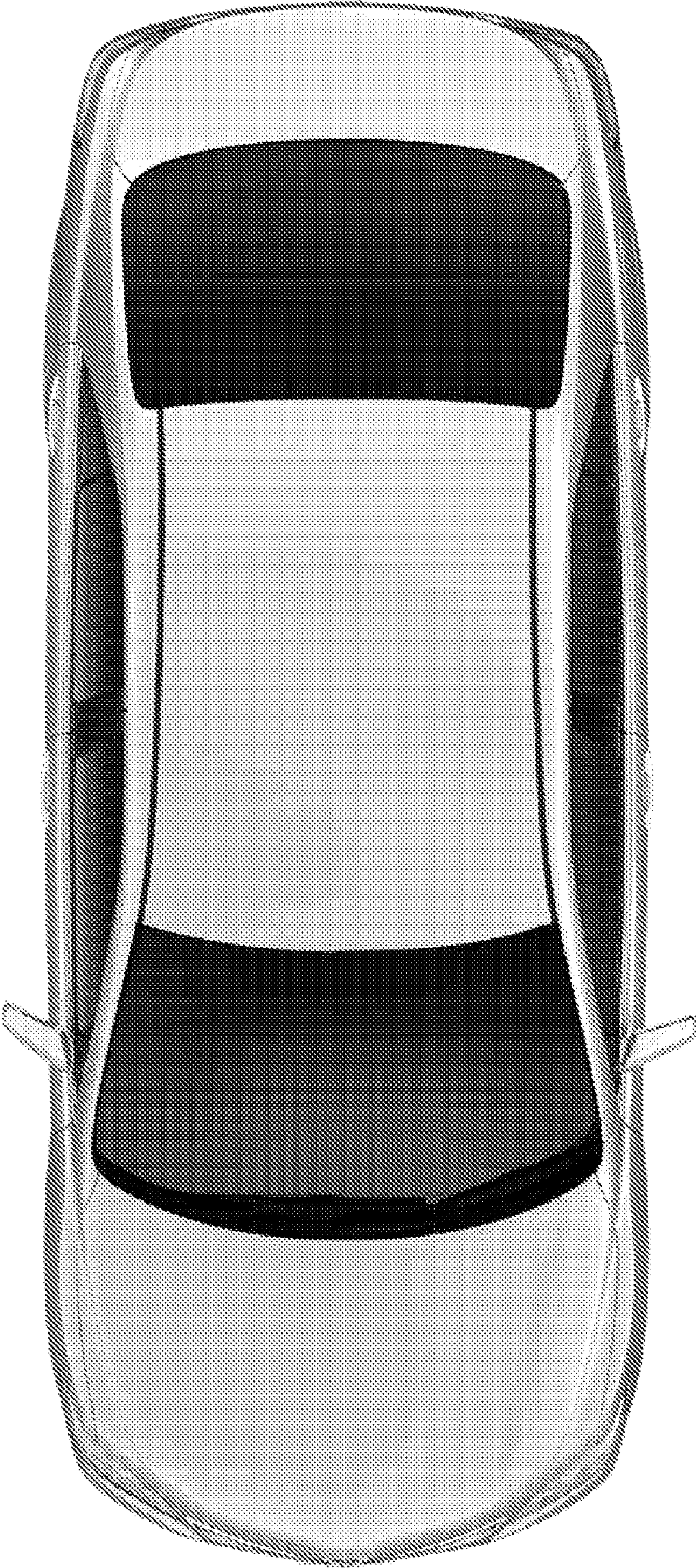

FIG. 6

UNITED STATES PATENT AND TRADEMARK OFFICE
CERTIFICATE OF CORRECTION

PATENT NO. : Des. 607,379 S
APPLICATION NO. : 29/329717
DATED : January 5, 2010
INVENTOR(S) : Kenichi Inukai, Manabu Hirokawa and Tomokazu Morikawa

Page 1 of 1

It is certified that error appears in the above-identified patent and that said Letters Patent is hereby corrected as shown below:

Title page, item (75) should read:

(75) Inventors: Kenichi Inukai, Toyota (JP); Manabu Hirokawa, Toyota (JP);
Tomokazu Morikawa, Kariya (JP); ~~Takafumi Ito, Kariya (JP);~~
~~Kazumi Kouwaki, Kariya (JP); Ryouusuke Yokoi, Kariya (JP);~~
~~Takeo Sowa, Kariya (JP)~~

Signed and Sealed this

Twenty-third Day of March, 2010



David J. Kappos
Director of the United States Patent and Trademark Office