



US00D607377S

(12) **United States Design Patent**  
**Shimomura et al.**

(10) **Patent No.:** **US D607,377 S**  
(45) **Date of Patent:** **\*\* Jan. 5, 2010**

(54) **TRANSPORT VEHICLE**

(75) Inventors: **Takashi Shimomura**, Takatsuki (JP);  
**Yoshitaka Higashikawa**, Sakai (JP)

(73) Assignee: **Kubota Corporation**, Osaka (JP)

(\*\*) Term: **14 Years**

(21) Appl. No.: **29/301,530**

(22) Filed: **Mar. 5, 2008**

(30) **Foreign Application Priority Data**

Sep. 18, 2007 (JP) ..... 2007-025169

(51) **LOC (9) Cl.** ..... **12-13**

(52) **U.S. Cl.** ..... **D12/14**

(58) **Field of Classification Search** ..... D12/87,  
D12/86, 1, 433, 15, 16, 107, 82, 88, 89, 90,  
D12/91, 92, 93; D15/30; D21/803; 180/233,  
180/908; 280/DIG. 5, 183, 184, 185, 186,  
280/28, 37.7

See application file for complete search history.

(56) **References Cited**

**U.S. PATENT DOCUMENTS**

D422,938	S	*	4/2000	Molzon et al.	.....	D12/1
D427,109	S	*	6/2000	Molzon et al.	.....	D12/1
D436,557	S	*	1/2001	Selby et al.	.....	D12/14
D439,548	S	*	3/2001	Kouchi et al.	.....	D12/1
6,523,879	B2	*	2/2003	Mizuta	.....	296/71
D494,890	S	*	8/2004	Katoh	.....	D12/14
D503,657	S	*	4/2005	Katoh	.....	D12/14
D511,317	S	*	11/2005	Tanaka et al.	.....	D12/1
D521,413	S	*	5/2006	Katoh	.....	D12/1
D578,934	S	*	10/2008	Tanaka et al.	.....	D12/14
2004/0222032	A1	*	11/2004	Nakatani et al.	.....	180/367
2005/0037892	A1	*	2/2005	Nakatani et al.	.....	477/120
2007/0210617	A1	*	9/2007	Nakamura	.....	296/190.08

2008/0084082 A1\* 4/2008 Nakamura et al. .... 296/37.15  
2008/0084091 A1\* 4/2008 Nakamura et al. .... 296/190.08

\* cited by examiner

*Primary Examiner*—T. Chase Nelson

*Assistant Examiner*—Ania K Dworzecka

(74) *Attorney, Agent, or Firm*—The Webb Law Firm

(57) **CLAIM**

The ornamental design for a transport vehicle, as shown and described.

**DESCRIPTION**

FIG. 1 is a right side elevation view of the transport vehicle showing our new design;

FIG. 2 is a left side elevation view thereof;

FIG. 3 is a front elevation view thereof;

FIG. 4 is a rear elevation view thereof;

FIG. 5 is a top plan view thereof;

FIG. 6 is a right front perspective view thereof;

FIG. 7 is a left front perspective view thereof;

FIG. 8 is a left rear perspective view thereof;

FIG. 9 is a right rear perspective view thereof;

FIG. 10 is a partially enlarged view thereof taken on line 10—10 in FIG. 1;

FIG. 11 is a partially enlarged view thereof taken on line 11—11 in FIG. 1;

FIG. 12 is a partially enlarged view thereof taken on line 12—12 in FIG. 2; and,

FIG. 13 is a partially enlarged view thereof taken on line 13—13 in FIG. 2.

The broken line showings in the figures are environmental only and not part of the claimed design.

**1 Claim, 13 Drawing Sheets**

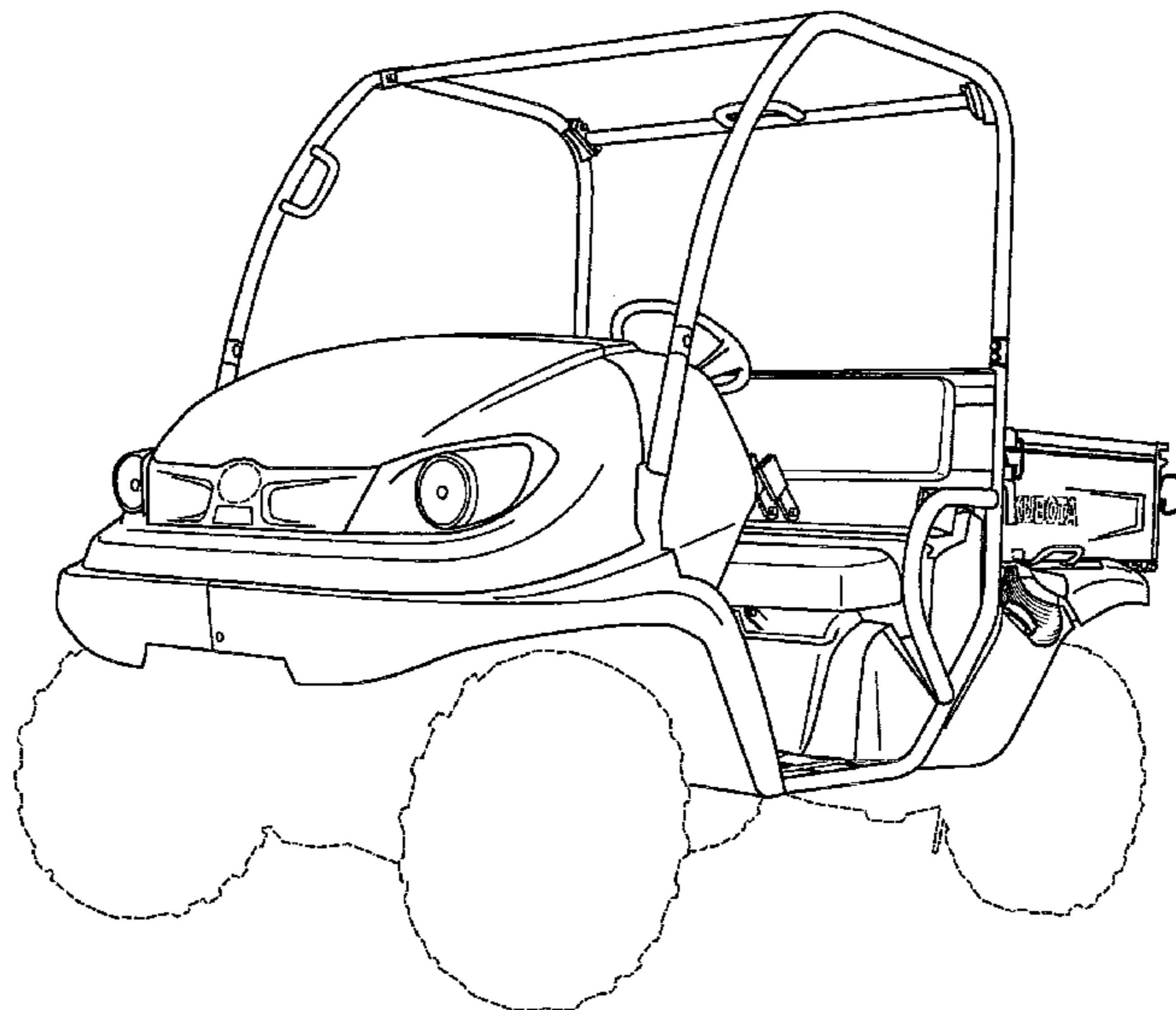

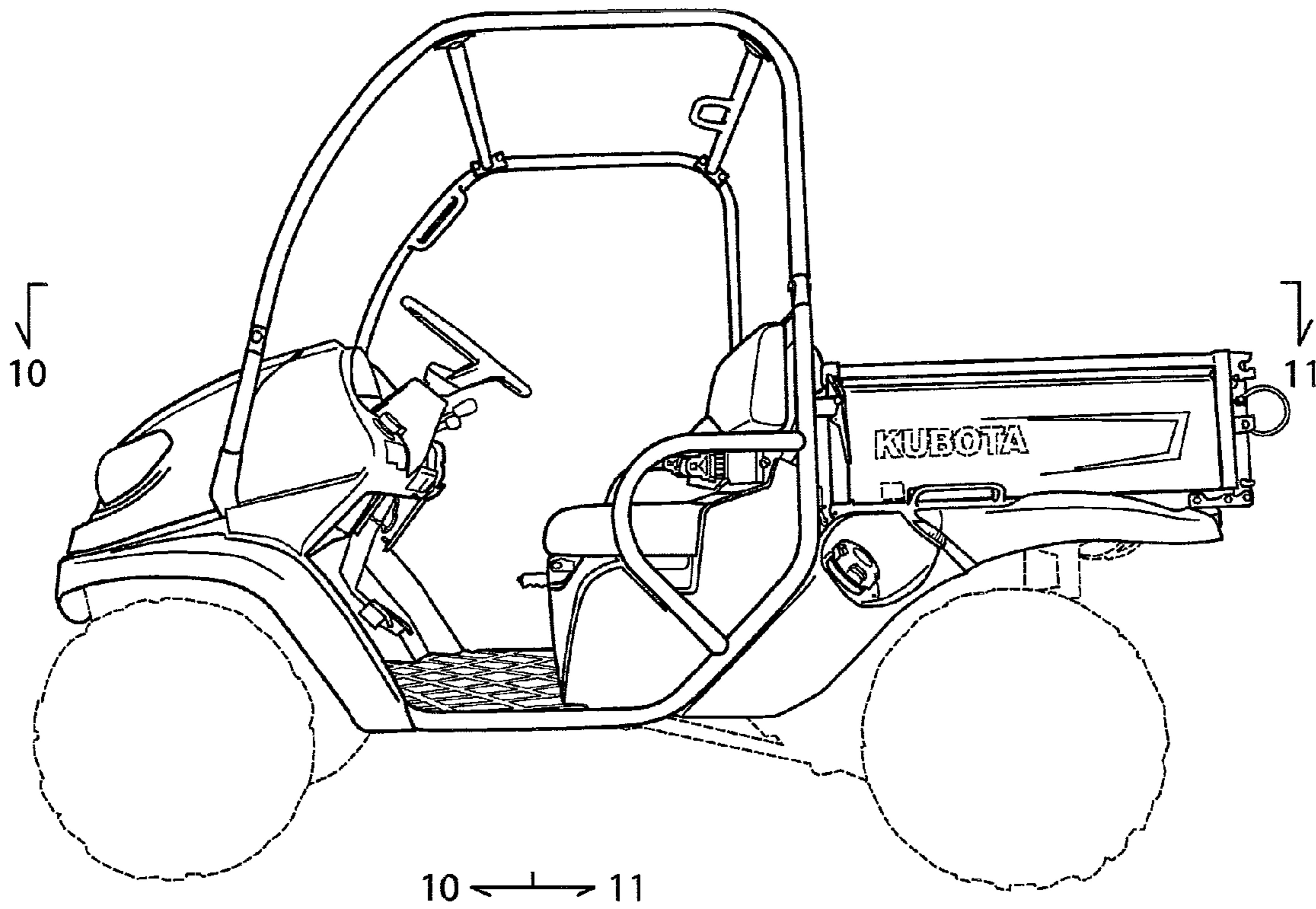

FIG. 1

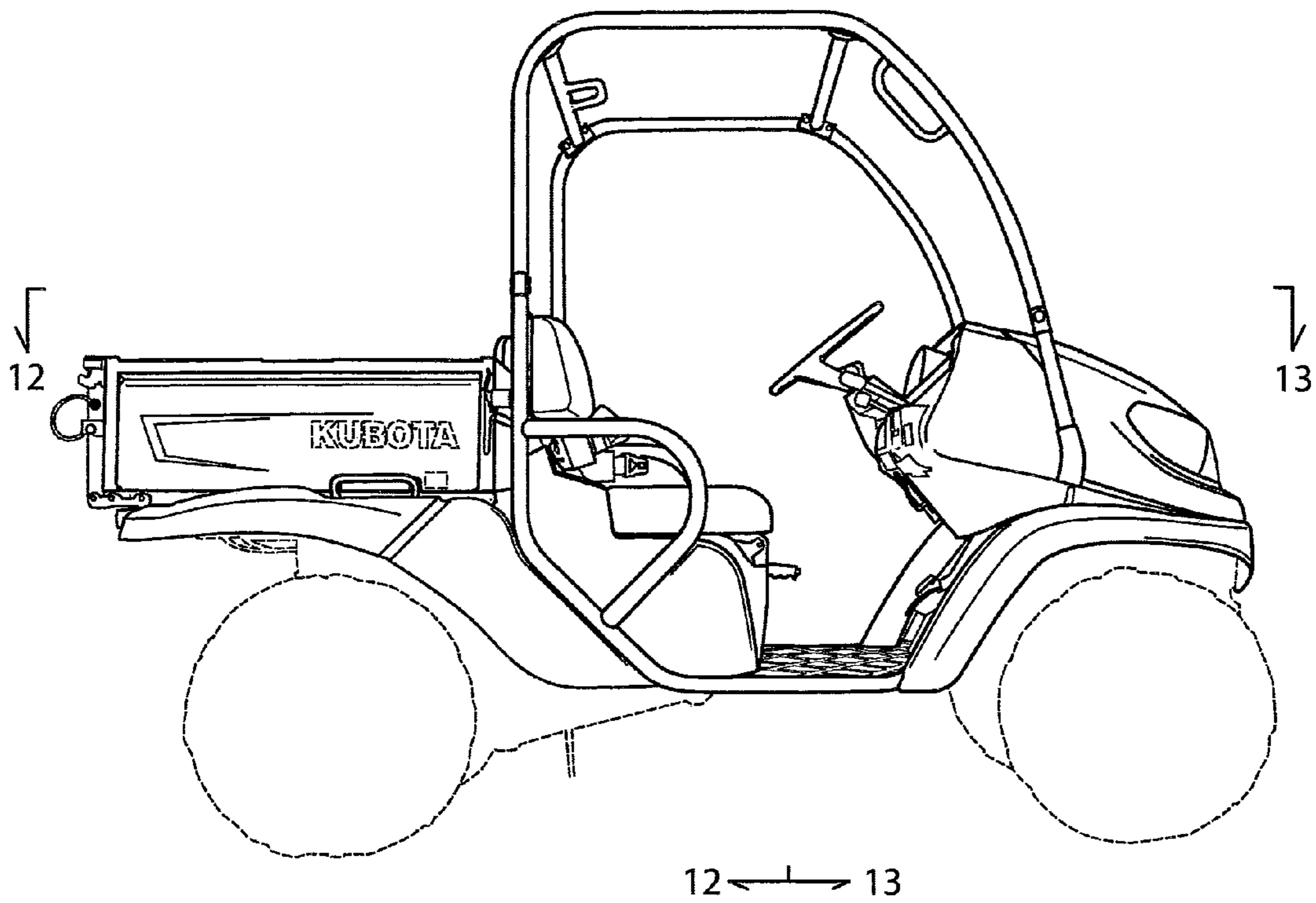
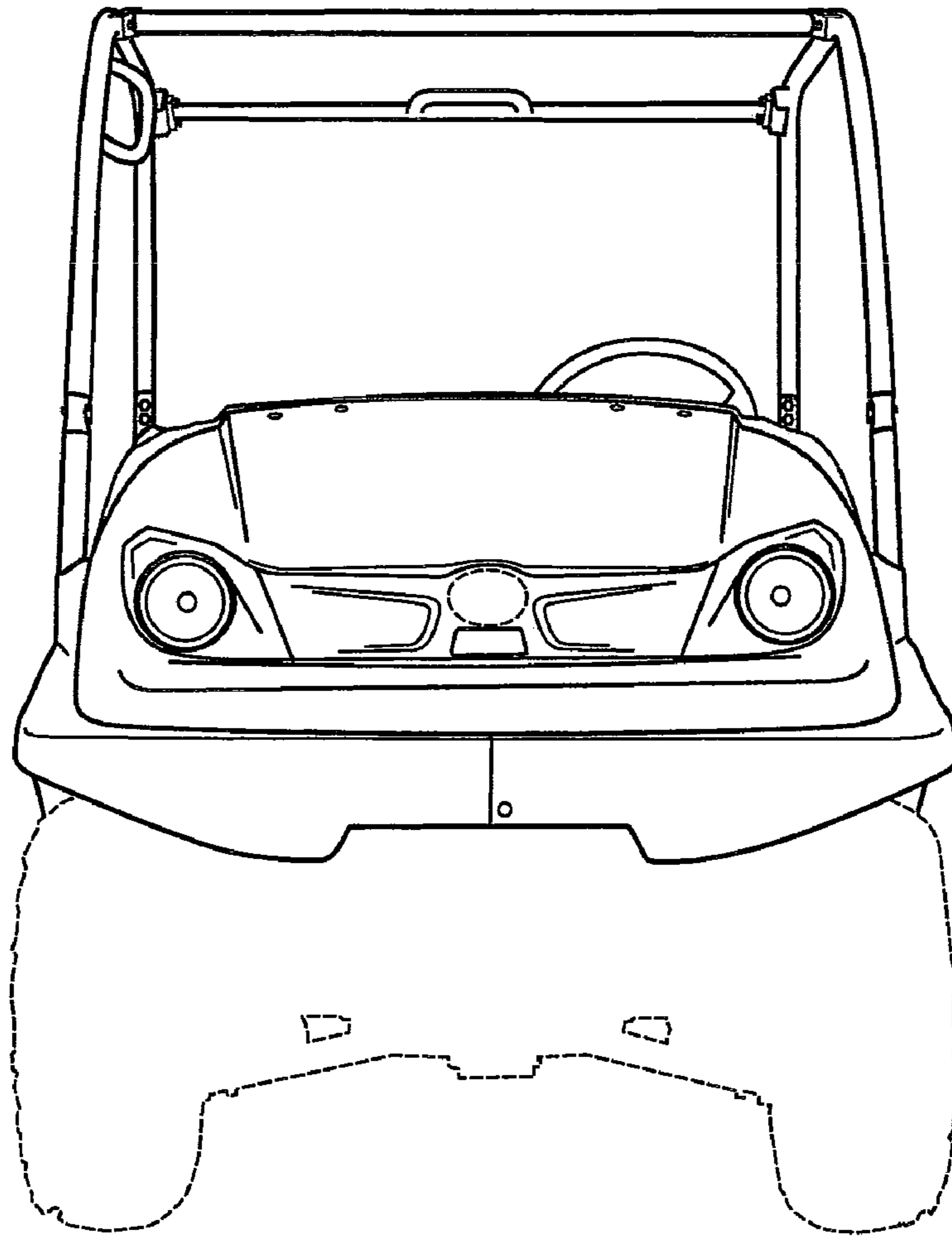
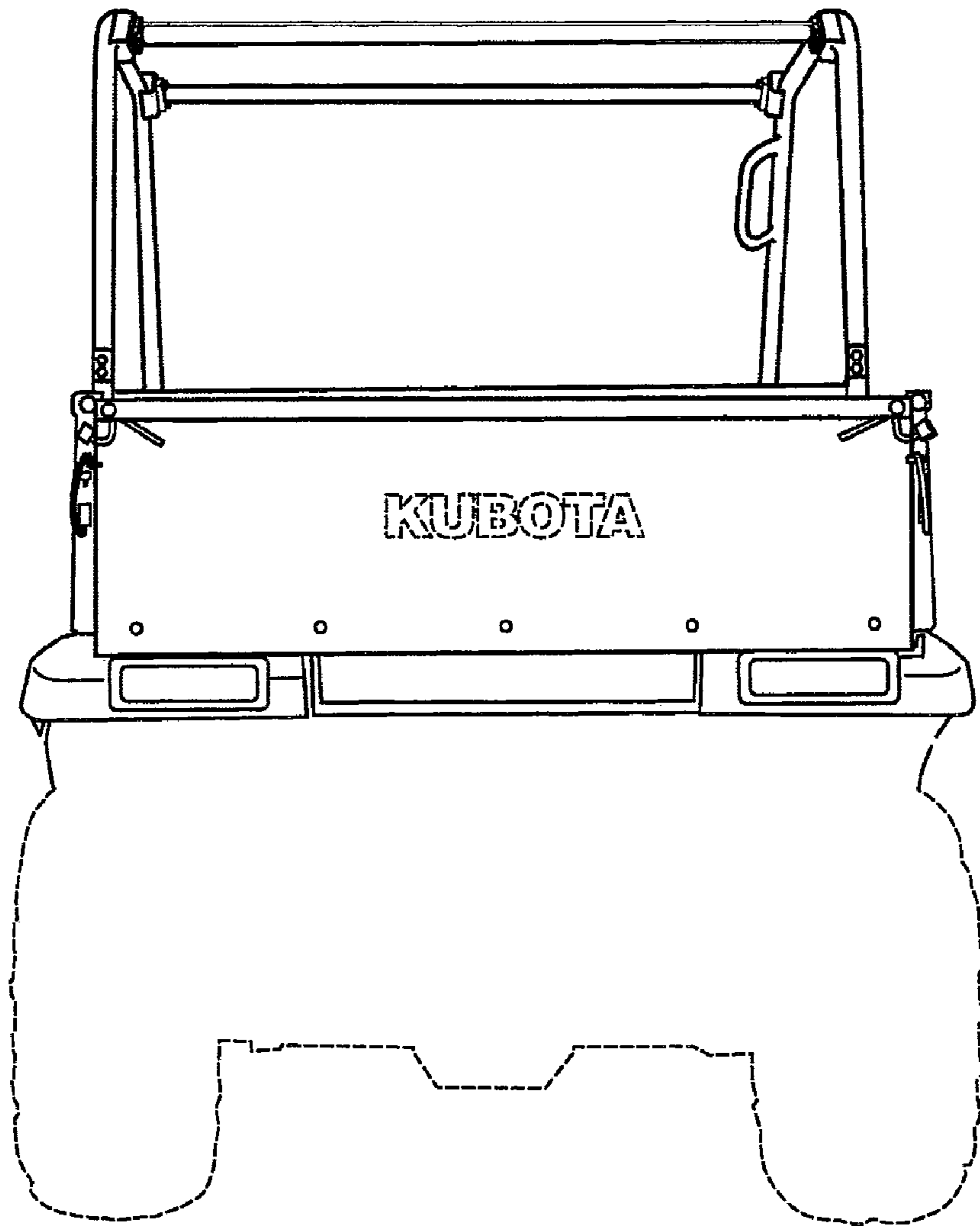

FIG. 2



**FIG. 3**



**FIG. 4**

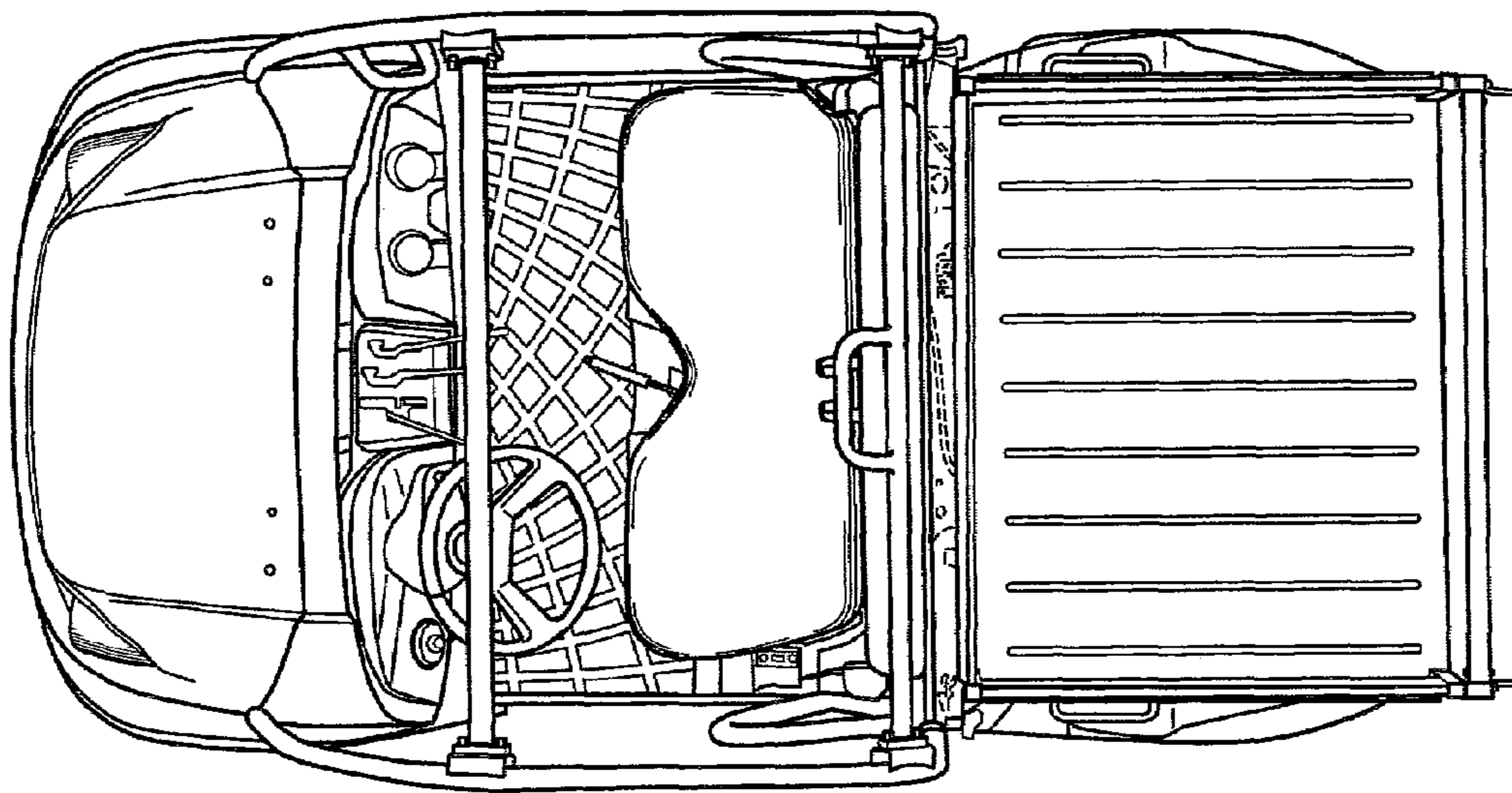
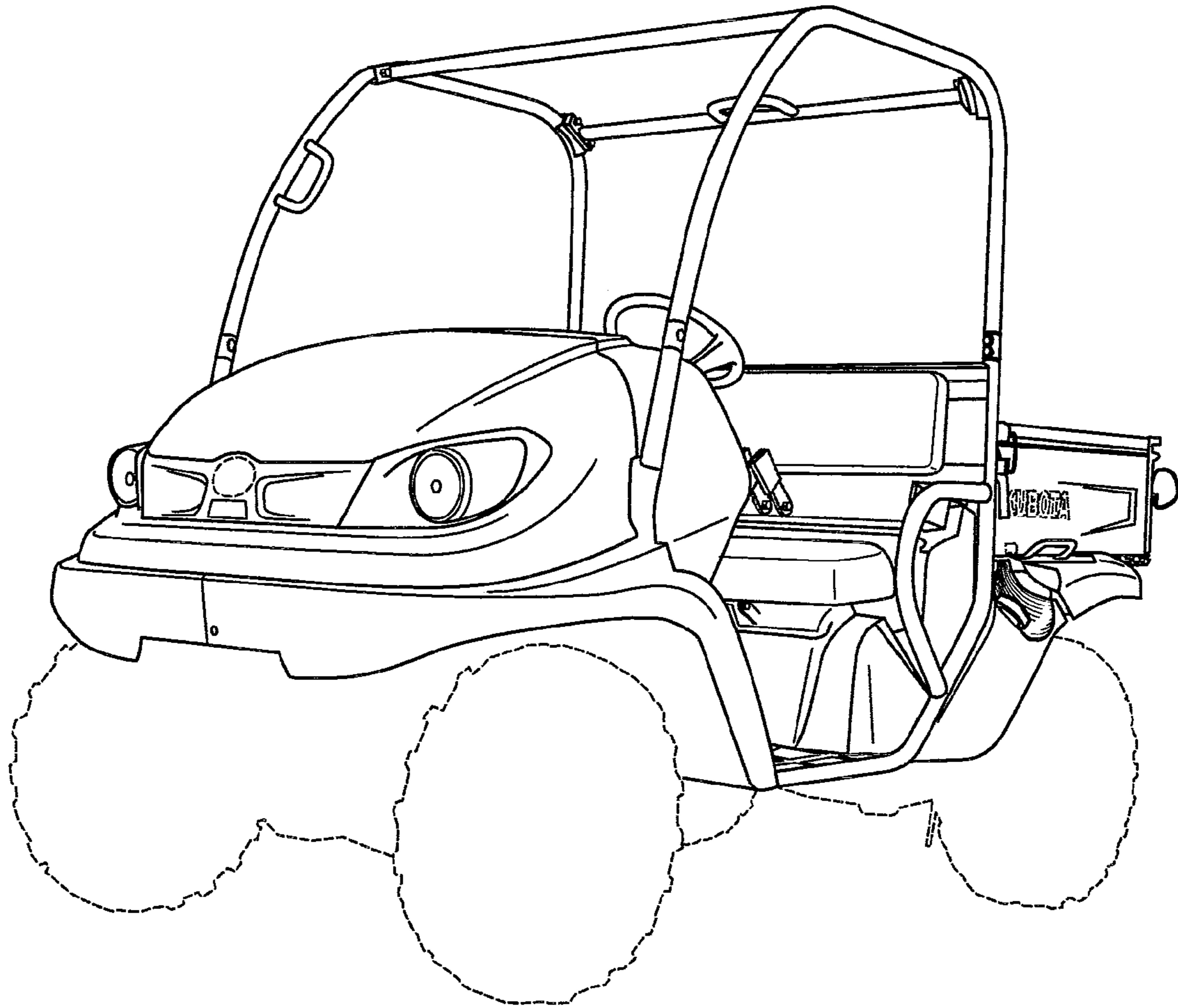
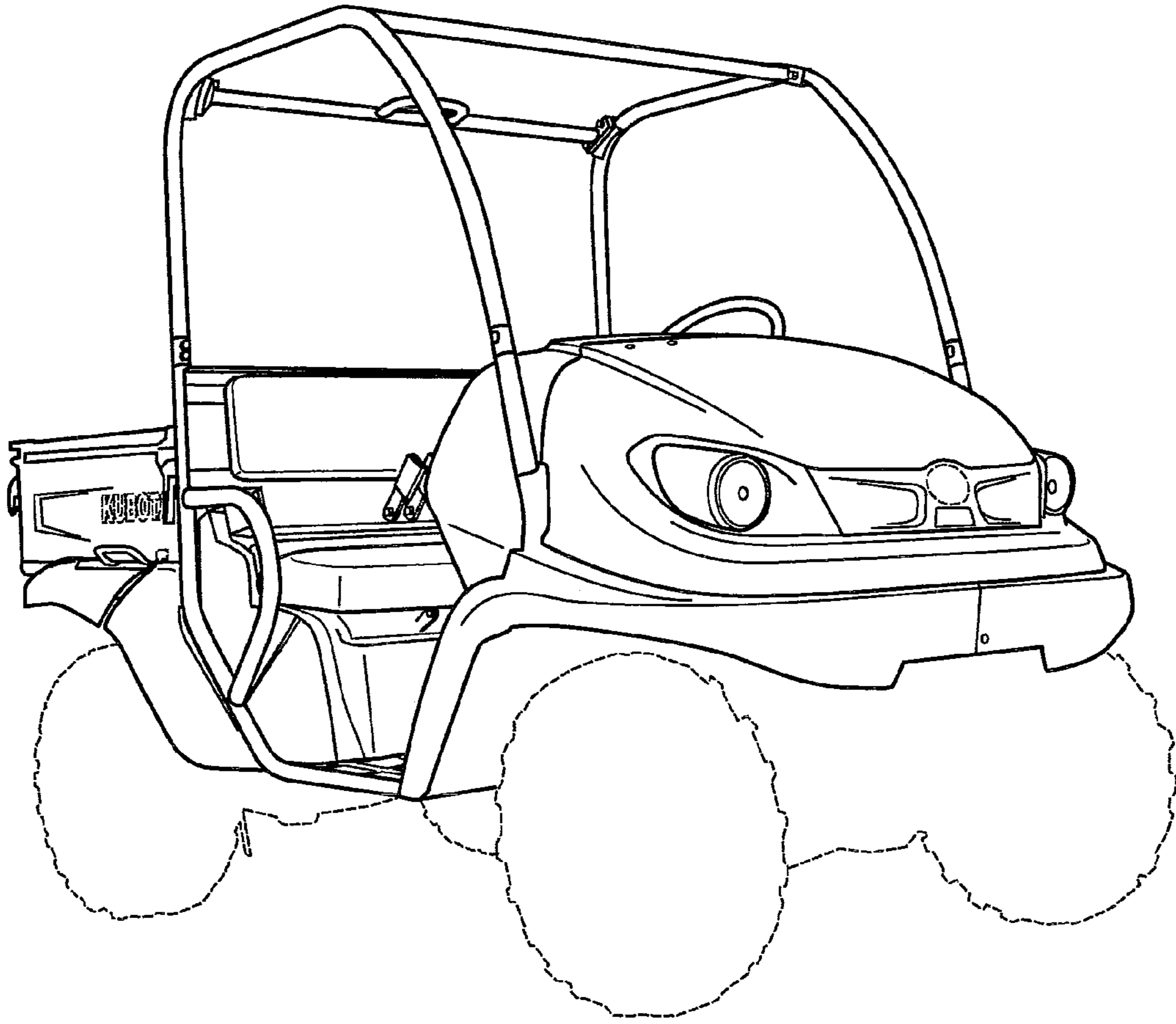

FIG. 5

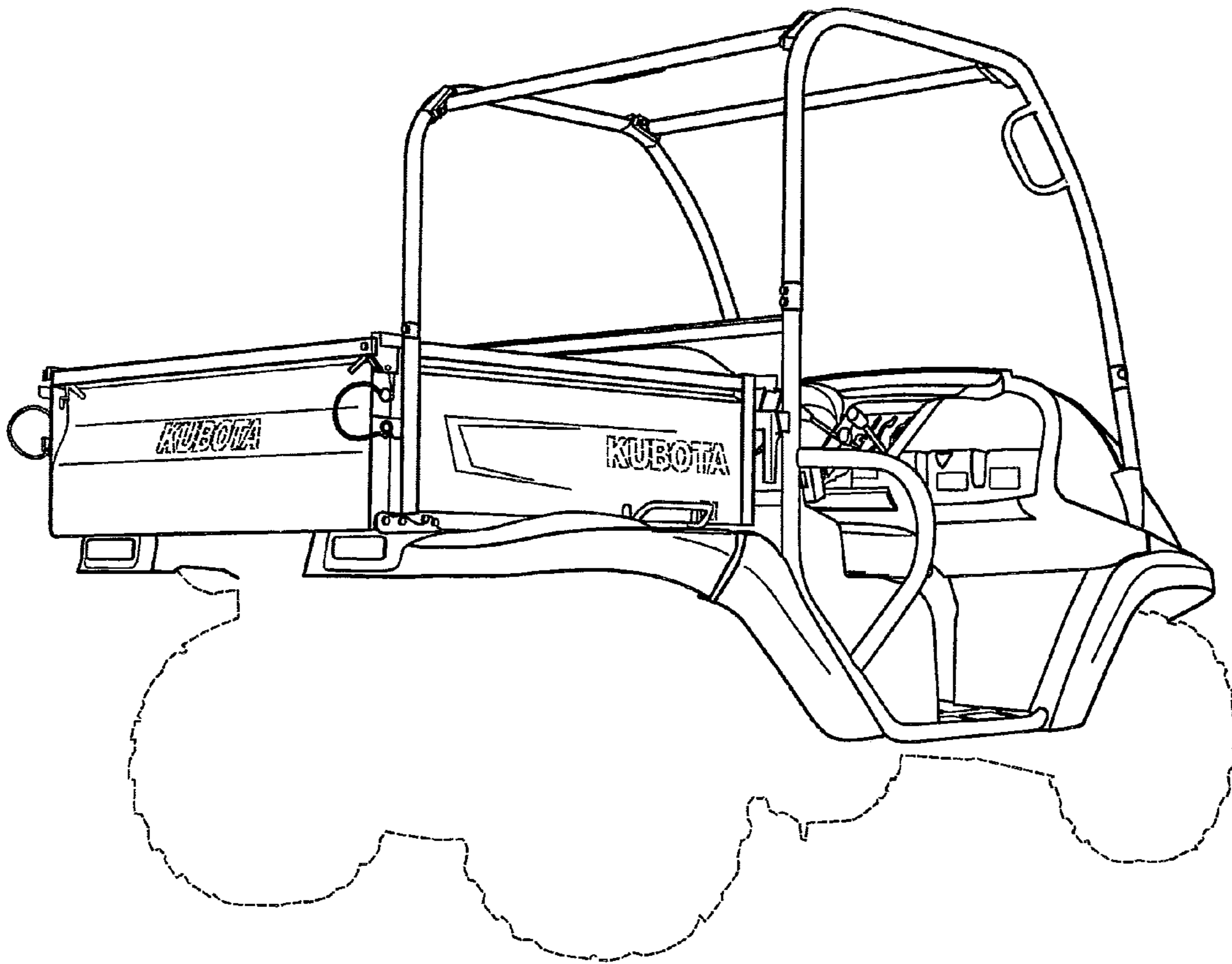

**FIG. 6**

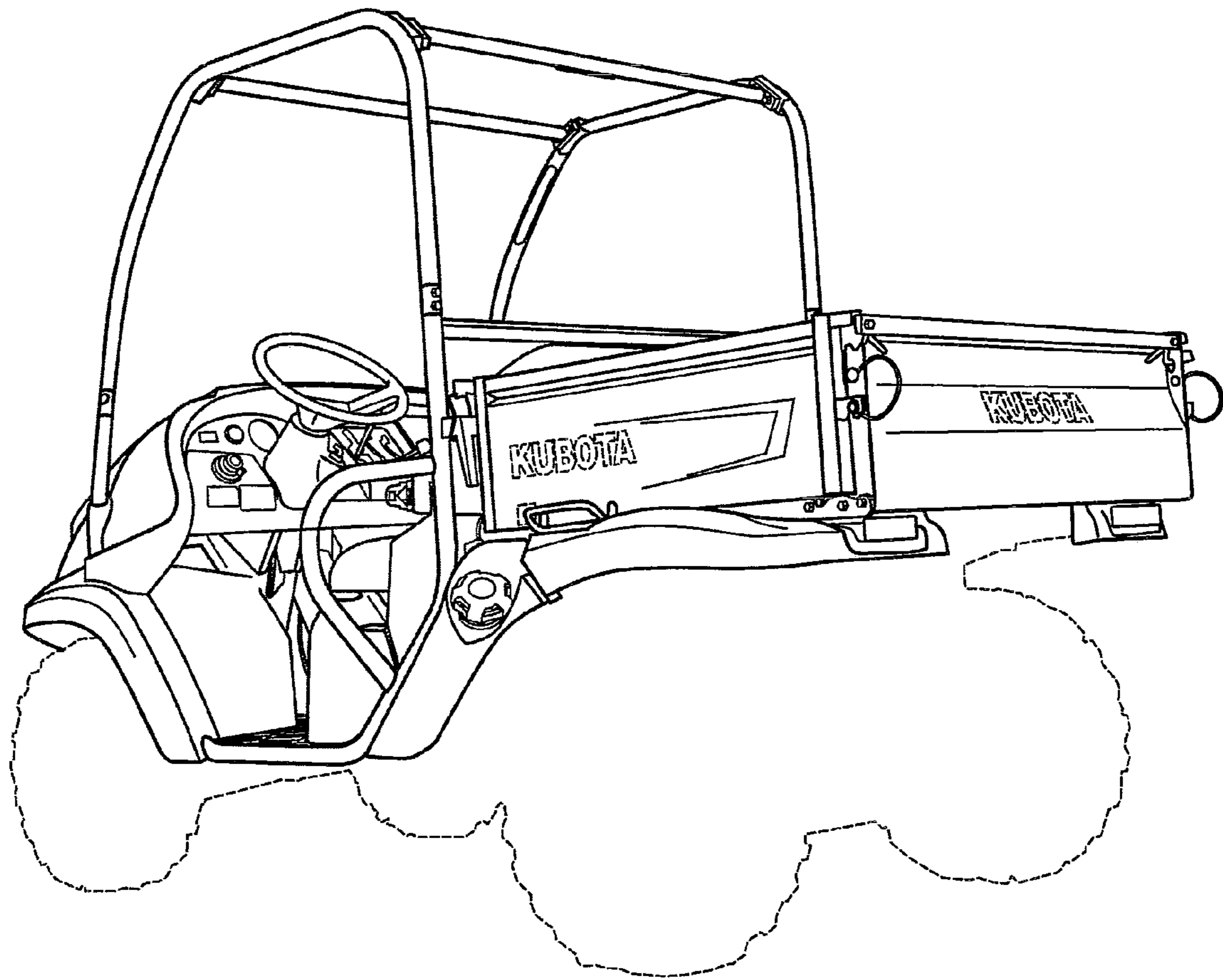

**FIG. 7**

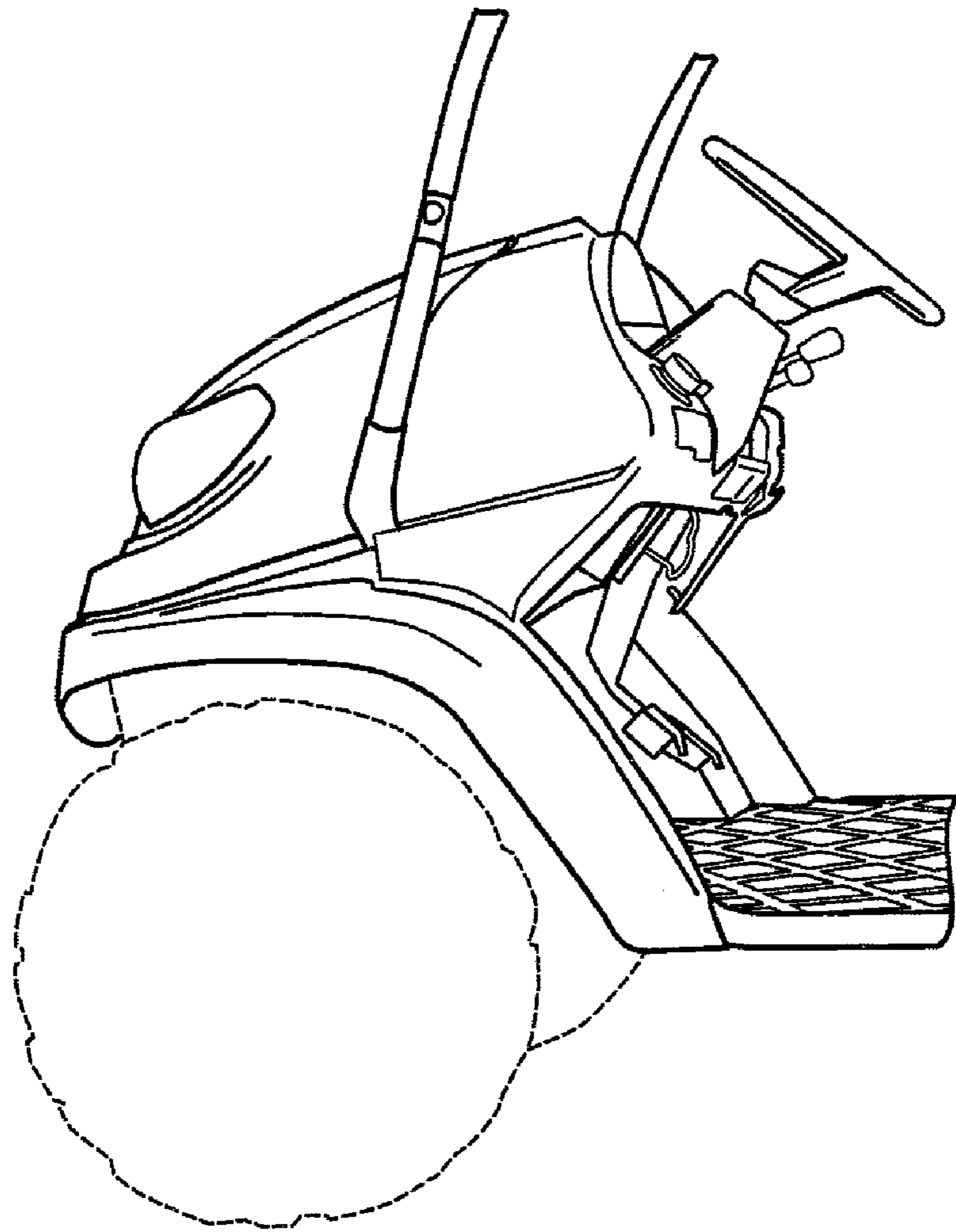



**FIG. 8**



**FIG. 9**



**FIG. 10**

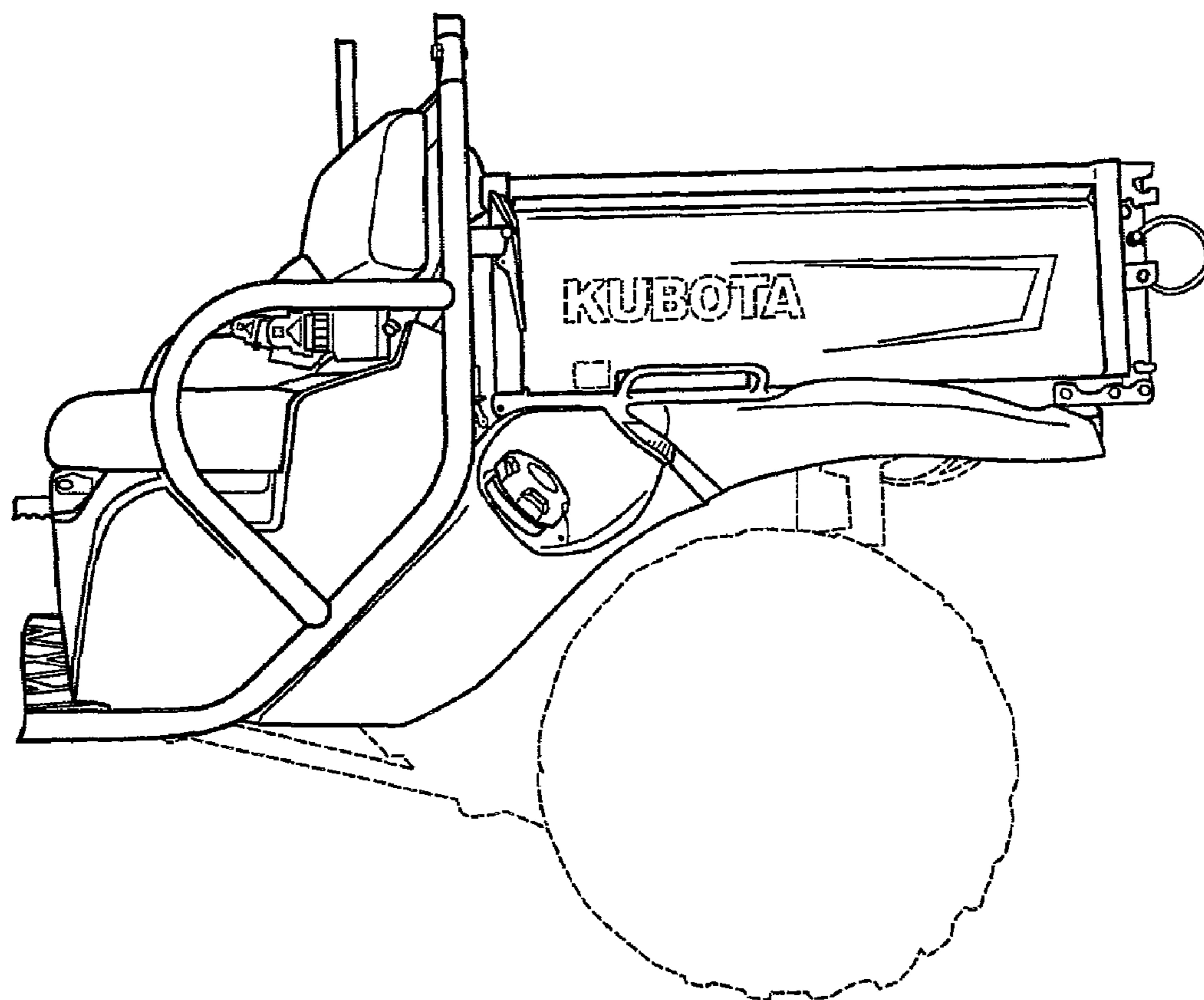

**FIG. 11**

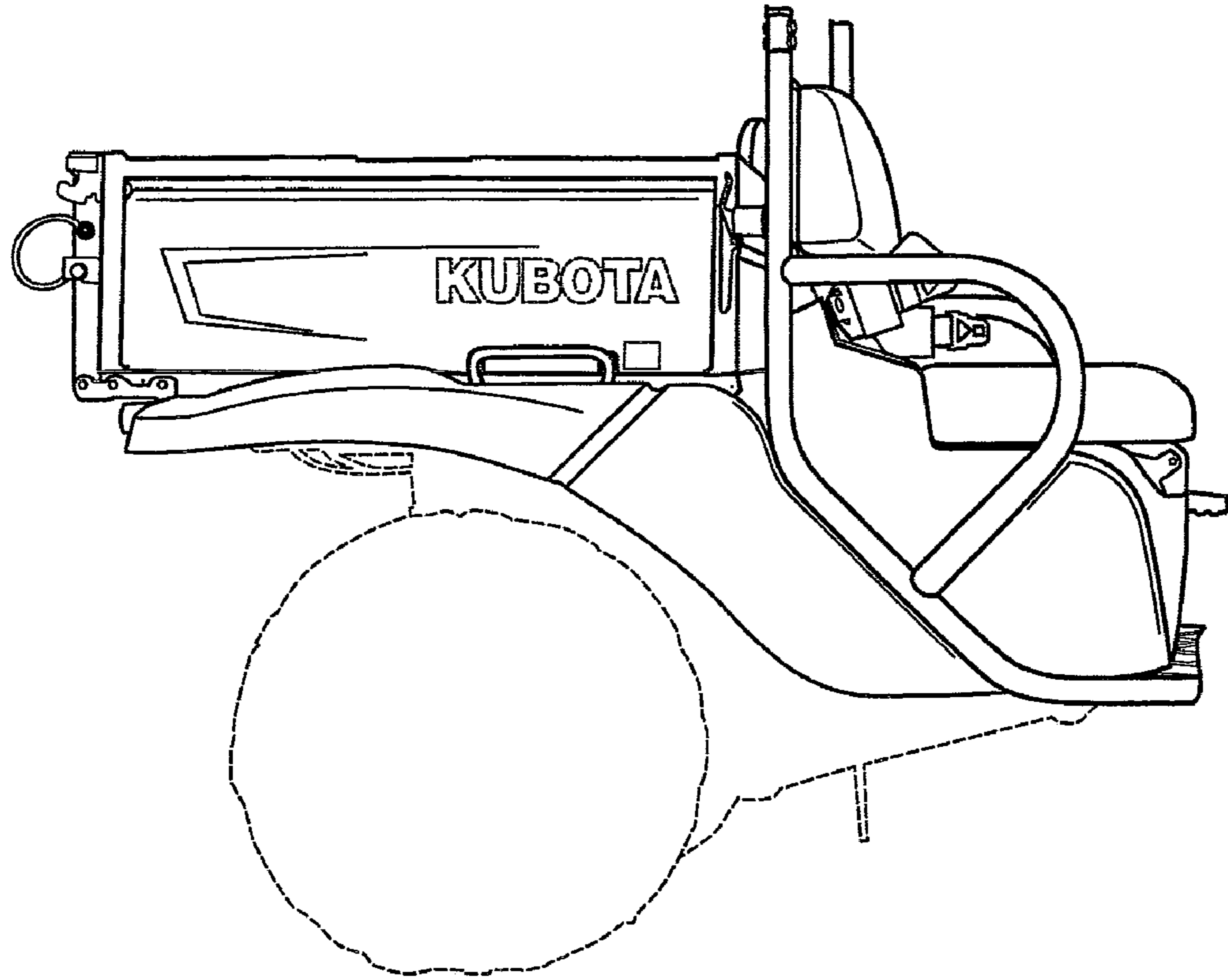

**FIG. 12**

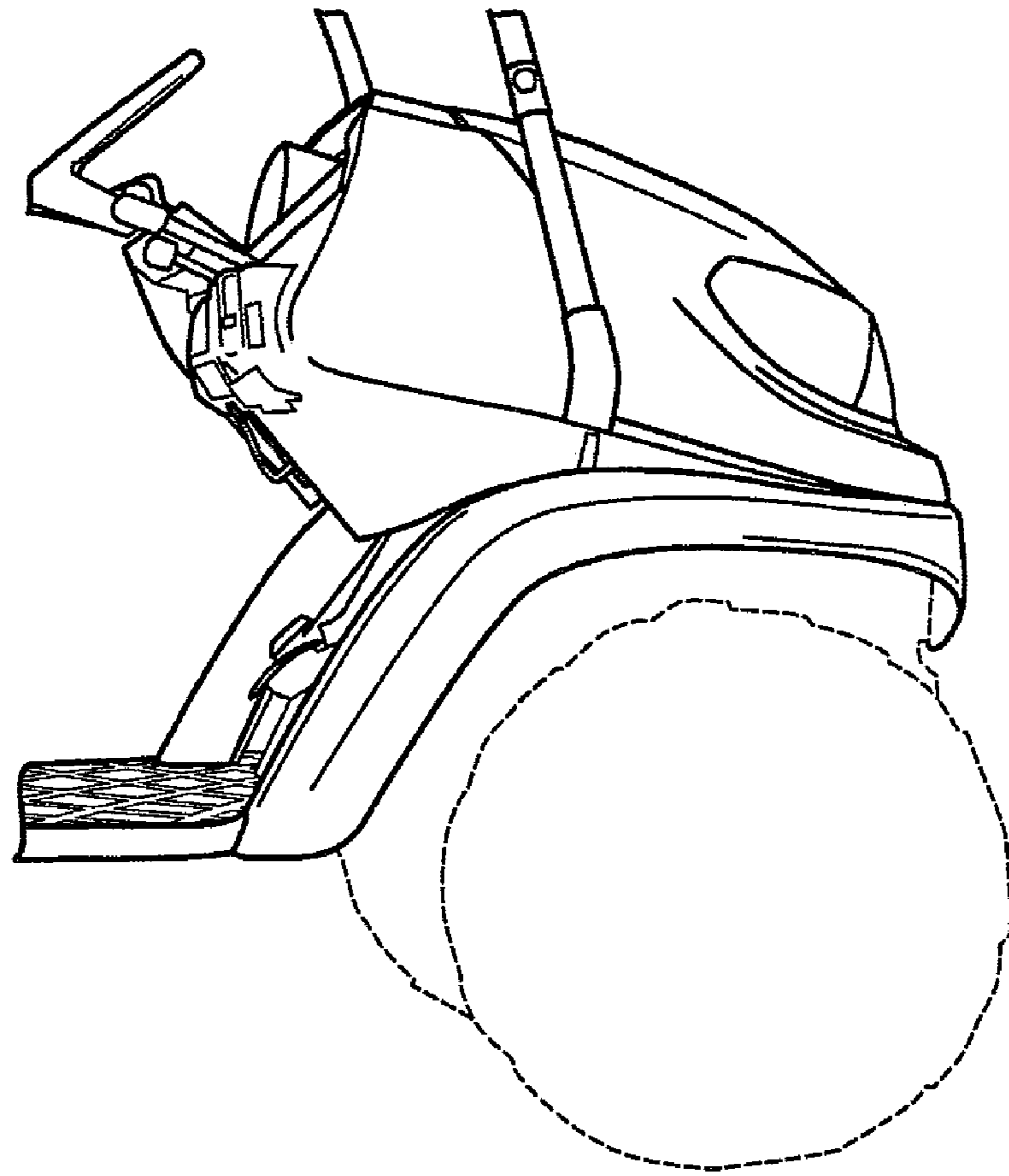

**FIG. 13**