



US00D607029S

(12) **United States Design Patent**
Stehle

(10) **Patent No.:** **US D607,029 S**
(45) **Date of Patent:** **** Dec. 29, 2009**

(54) **CONTAINER FOR TIRE SEALANT WITH ATTACHED DEVICE FOR INJECTING TIRE SEALANT INTO VEHICLE TIRES**

(75) Inventor: **Michael Stehle**, Uberlingen (DE)

(73) Assignee: **Doukas AG**, Kreuzlingen (CH)

(**) Term: **14 Years**

(21) Appl. No.: **29/331,555**

(22) Filed: **Jan. 28, 2009**

Related U.S. Application Data

(63) Continuation-in-part of application No. 29/269,256, filed on Nov. 27, 2006, now abandoned.

(51) **LOC (9) Cl.** **15-99**

(52) **U.S. Cl.** **D15/199**

(58) **Field of Classification Search** D8/105, D8/499; D9/434, 440, 528, 531, 544; D15/140, D15/199; D23/202, 213, 225; 141/38, 67, 141/100; 152/415; 239/142, 154, 333
See application file for complete search history.

(56) **References Cited**

U.S. PATENT DOCUMENTS

D309,858	S	*	8/1990	Meyersburg	D23/225
D347,047	S	*	5/1994	Wood	D23/225
5,765,601	A	*	6/1998	Wells et al.	141/38
D431,279	S	*	9/2000	Spriegel	D23/225
6,506,273	B1	*	1/2003	Hull	156/115
6,964,284	B2	*	11/2005	Eckhardt	141/38
D516,167	S	*	2/2006	Leer et al.	D23/225
D570,447	S	*	6/2008	Hillhouse	D23/225
2003/0024596	A1	*	2/2003	Kojima et al.	141/38
2005/0247369	A1	*	11/2005	Dudley	141/38
2007/0181209	A1	*	8/2007	Stehle	141/38
2008/0060734	A1	*	3/2008	Stehle	152/416
2008/0202632	A1	*	8/2008	Hung	141/38
2008/0264540	A1	*	10/2008	Dowel	152/509

2009/0107578 A1* 4/2009 Trachtenberg et al. 141/5

* cited by examiner

Primary Examiner—Sandra Snapp

Assistant Examiner—Patricia Palasik

(74) *Attorney, Agent, or Firm*—Bachman & LaPointe, P.C.

(57) **CLAIM**

The ornamental design for a container for tire sealant with attached device for injecting tire sealant into vehicle tires, as shown and described.

DESCRIPTION

FIG. 1 is a perspective view of the container for tire sealant with attached device for injecting tire sealant into vehicle tires of the present invention;

FIG. 2 is a left side view of the container for tire sealant with attached device for injecting tire sealant into vehicle tires of FIG. 1;

FIG. 3 is a right side view of the container for tire sealant with attached device for injecting tire sealant into vehicle tires of FIG. 1;

FIG. 4 is a front view of the container for tire sealant with attached device for injecting tire sealant into vehicle tires of FIG. 1;

FIG. 5 is a rear view of the container for tire sealant with attached device for injecting tire sealant into vehicle tires of FIG. 1;

FIG. 6 is a top view of the container for tire sealant with attached device for injecting tire sealant into vehicle tires of FIG. 1; and,

FIG. 7 is a bottom view of the container for tire sealant with attached device for injecting tire sealant into vehicle tires of FIG. 1.

The broken lines in the drawings depict unclaimed environmental subject matter.

1 Claim, 5 Drawing Sheets

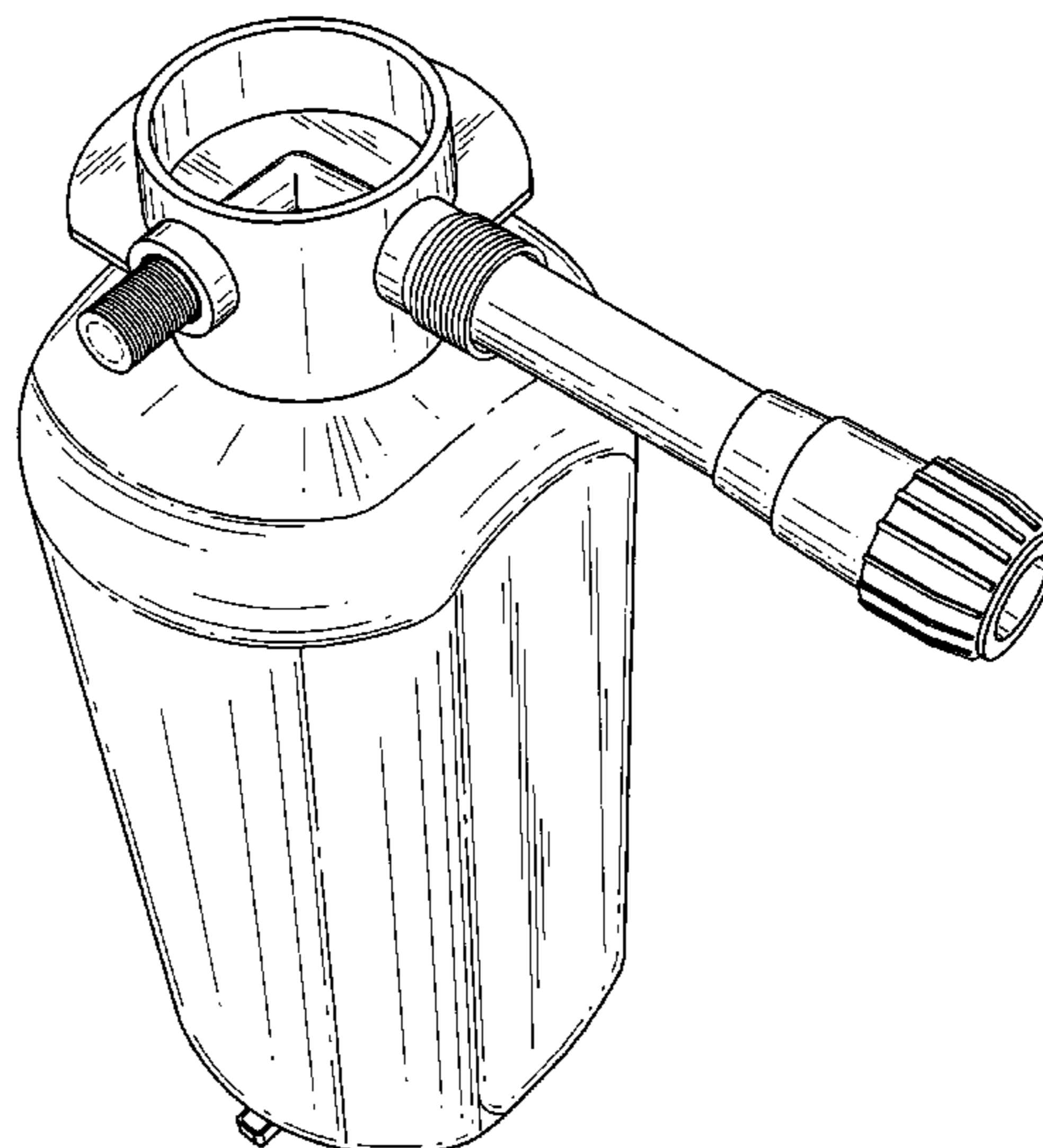

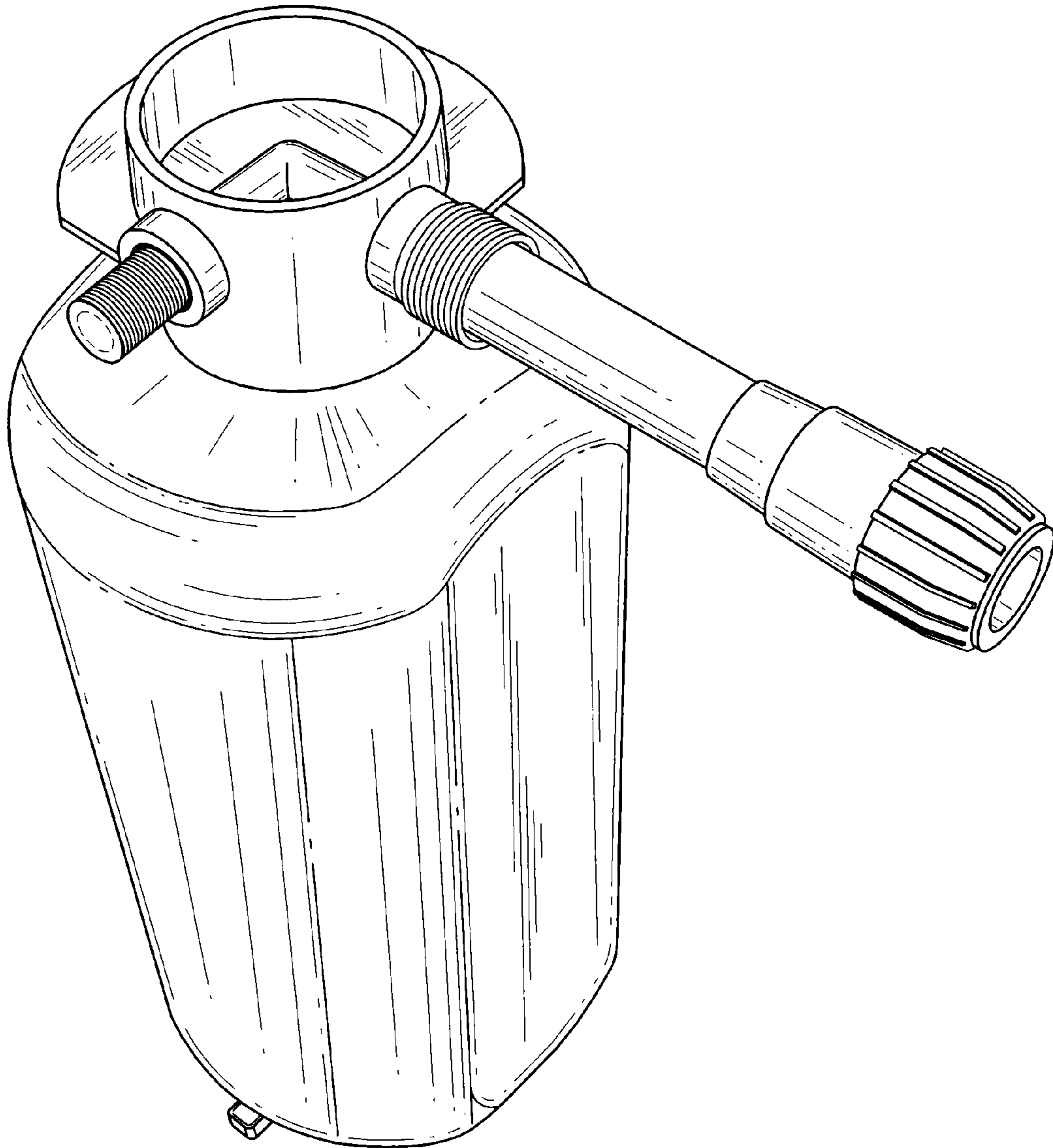

FIG. 1

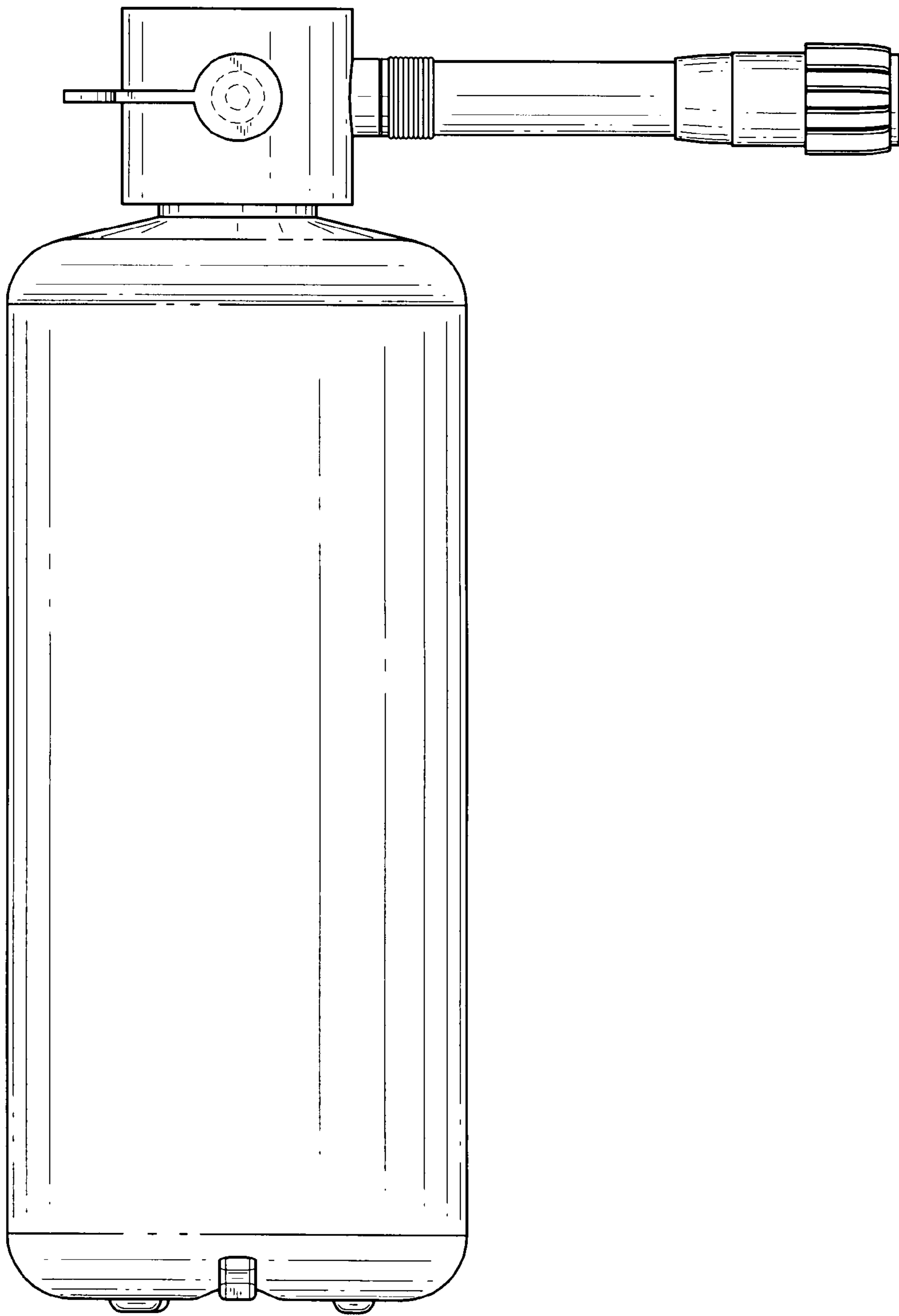

FIG. 2

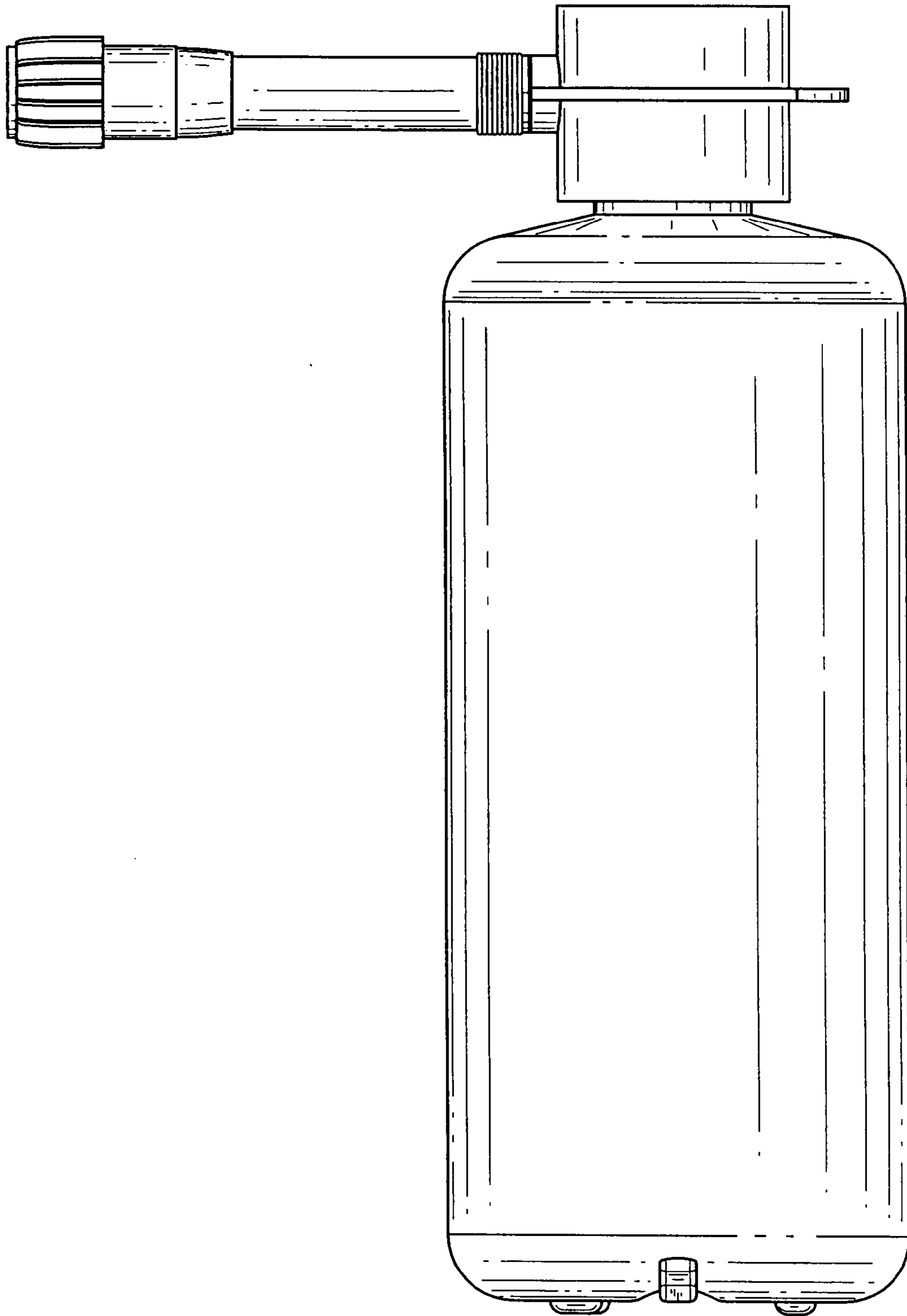

FIG. 3

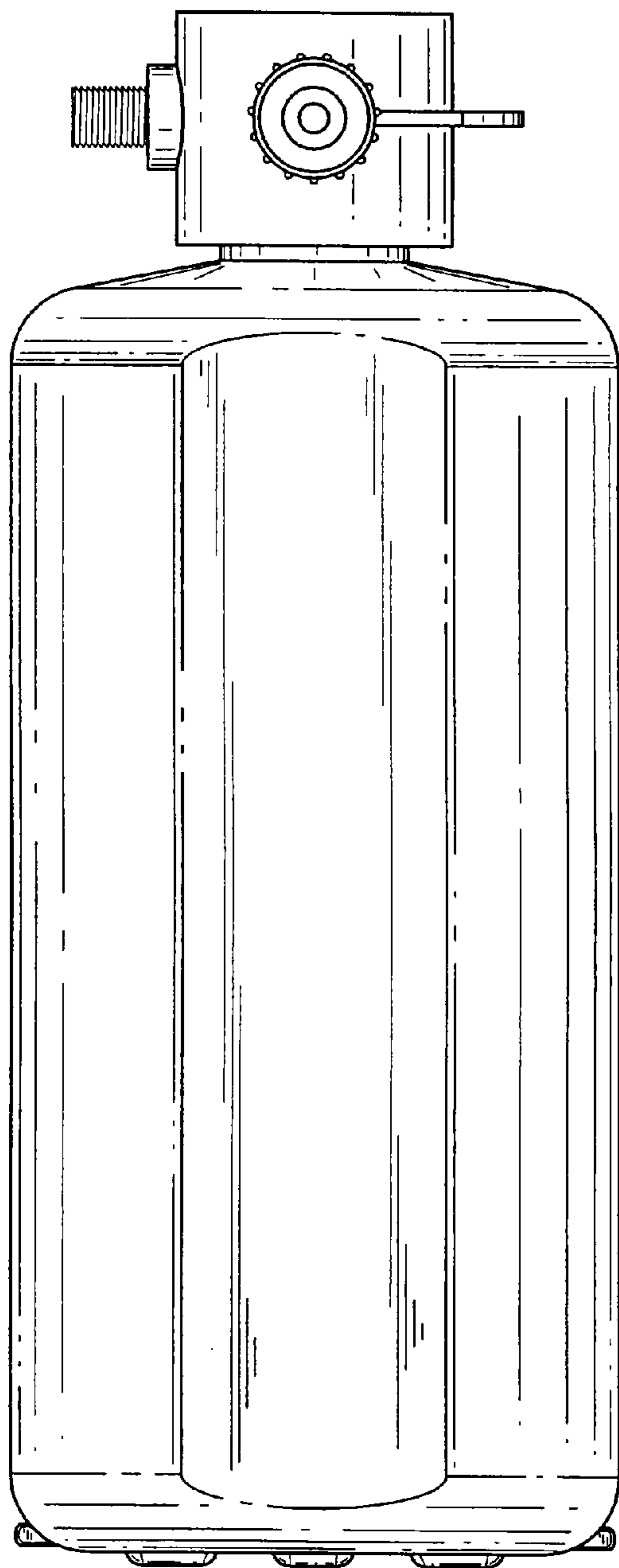

FIG. 4

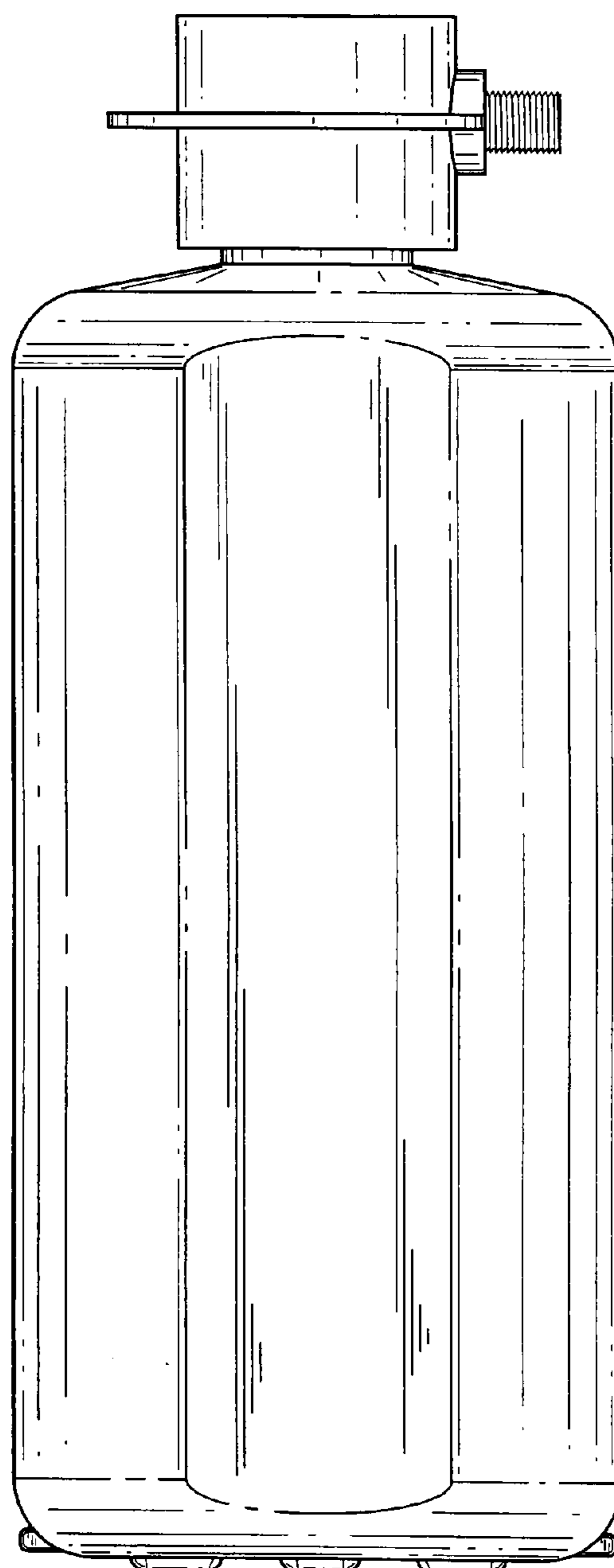

FIG. 5

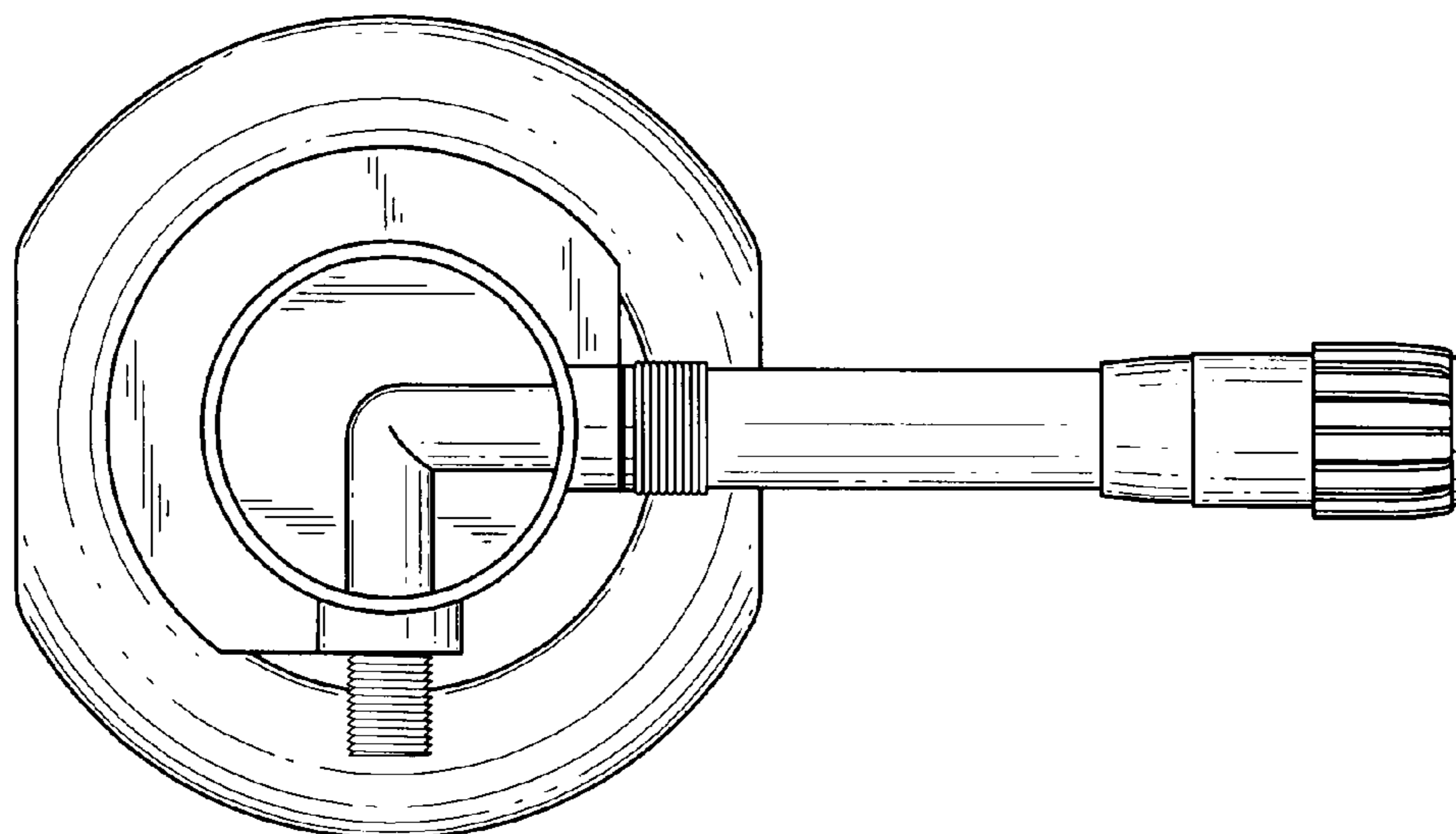

FIG. 6

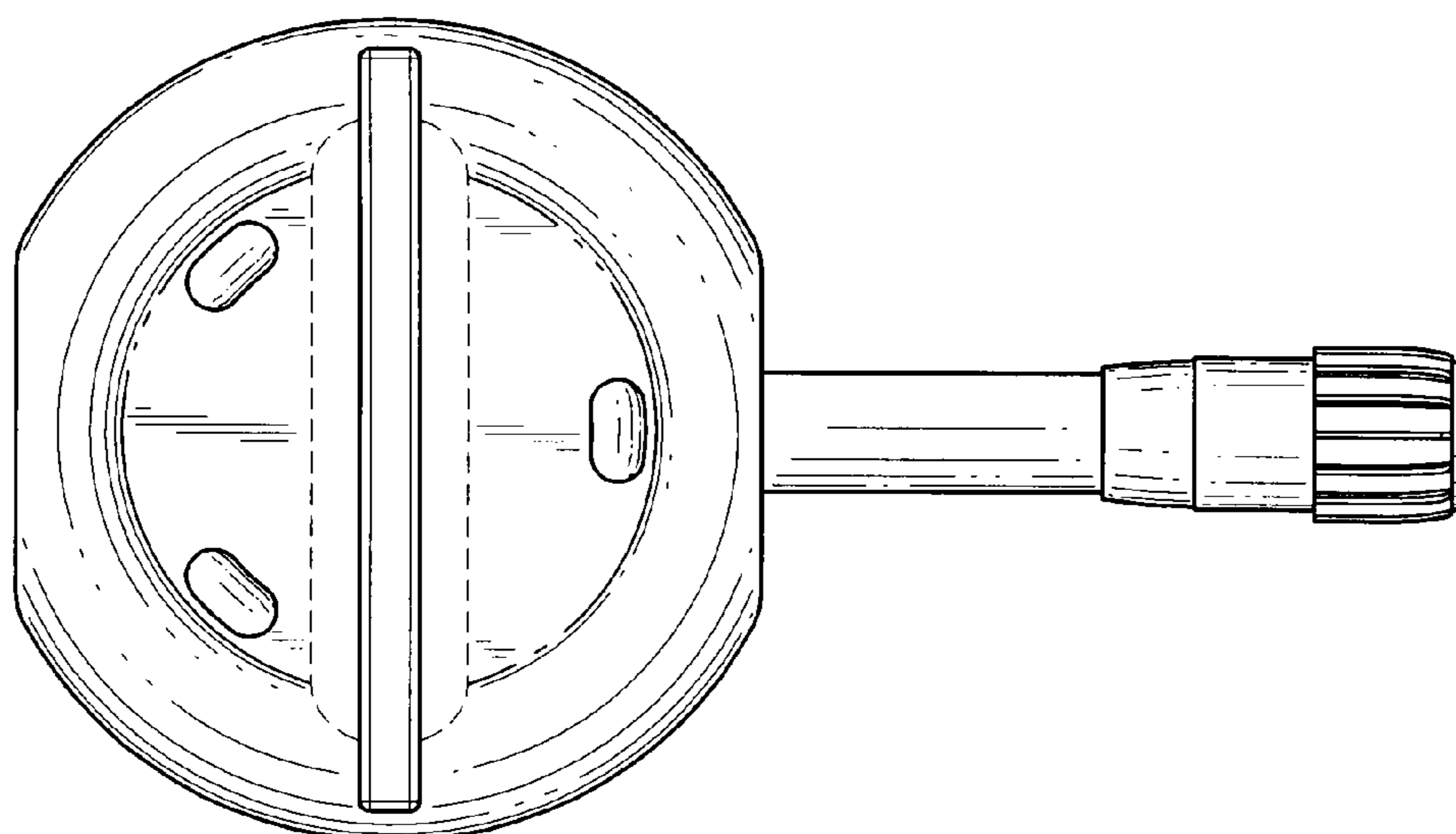

FIG. 7