

US00D606915S

(12) **United States Design Patent**  
**Booker**

(10) **Patent No.:** **US D606,915 S**

(45) **Date of Patent:** **\*\* Dec. 29, 2009**

(54) **PADDED COVER FOR A GEAR SHIFT**

(76) Inventor: **Keith Booker**, P.O. Box 4112, Virginia Beach, VA (US) 23454

(\*\*) Term: **14 Years**

(21) Appl. No.: **29/302,589**

(22) Filed: **Jan. 18, 2008**

(51) **LOC (9) Cl.** ..... **12-16**

(52) **U.S. Cl.** ..... **D12/179**

(58) **Field of Classification Search** ..... D12/174,  
D12/179, 400, 606; D8/301, 303, 305, 307,  
D8/310, 315; D7/393; D13/165, 171; 74/473.1,  
74/475, 489, 523; 16/433; 40/331; 292/347,  
292/348; 396/6; 455/345, 352

See application file for complete search history.

(56) **References Cited**

**U.S. PATENT DOCUMENTS**

4,869,305 A *	9/1989	Jones	.....	150/155
D411,497 S *	6/1999	Lagaay	.....	D12/179
D416,525 S *	11/1999	Sacco et al.	.....	D12/179
D432,892 S *	10/2000	Nakatani et al.	.....	D8/307
D440,919 S *	4/2001	Pfeiffer	.....	D12/179
D463,765 S *	10/2002	Pfeiffer et al.	.....	D12/179
D484,078 S *	12/2003	Hartono et al.	.....	D12/179
D491,120 S *	6/2004	Watanabe	.....	D12/179
D492,629 S *	7/2004	Hartono et al.	.....	D12/179
D498,189 S *	11/2004	Ligneau	.....	D12/179
D554,567 S *	11/2007	Landestoy	.....	D12/179

D562,738 S \* 2/2008 Young ..... D12/126

\* cited by examiner

*Primary Examiner*—Robert M Spear

*Assistant Examiner*—Cynthia Underwood

(57) **CLAIM**

The ornamental design for padded cover for a gear shift, as shown and described.

**DESCRIPTION**

FIG. 1 is a perspective view of a padded cover for a gear shift, illustrating the upper portion of the pad in an engaged position;

FIG. 2 is a front elevational view thereof;

FIG. 3 is a rear elevational view thereof;

FIG. 4 is a left-side elevational view thereof;

FIG. 5 is a right-side elevational view thereof;

FIG. 6 is a top plan view thereof;

FIG. 7 is a bottom plan view thereof; and,

FIG. 8 is a right-side elevational view of the invention, illustrating the upper portion of the pad in a disengaged position.

The broken lines in FIG. 1 showing a gear shift column illustrate the invention in use and in FIG. 7 the broken lines represent the boundary of the claim. The broken lines form no part of the claimed design. The broken lines surrounding the pen and pencil holder in FIGS. 2, 3, 5 and 8 represent stitching and are included in the claim.

**1 Claim, 3 Drawing Sheets**

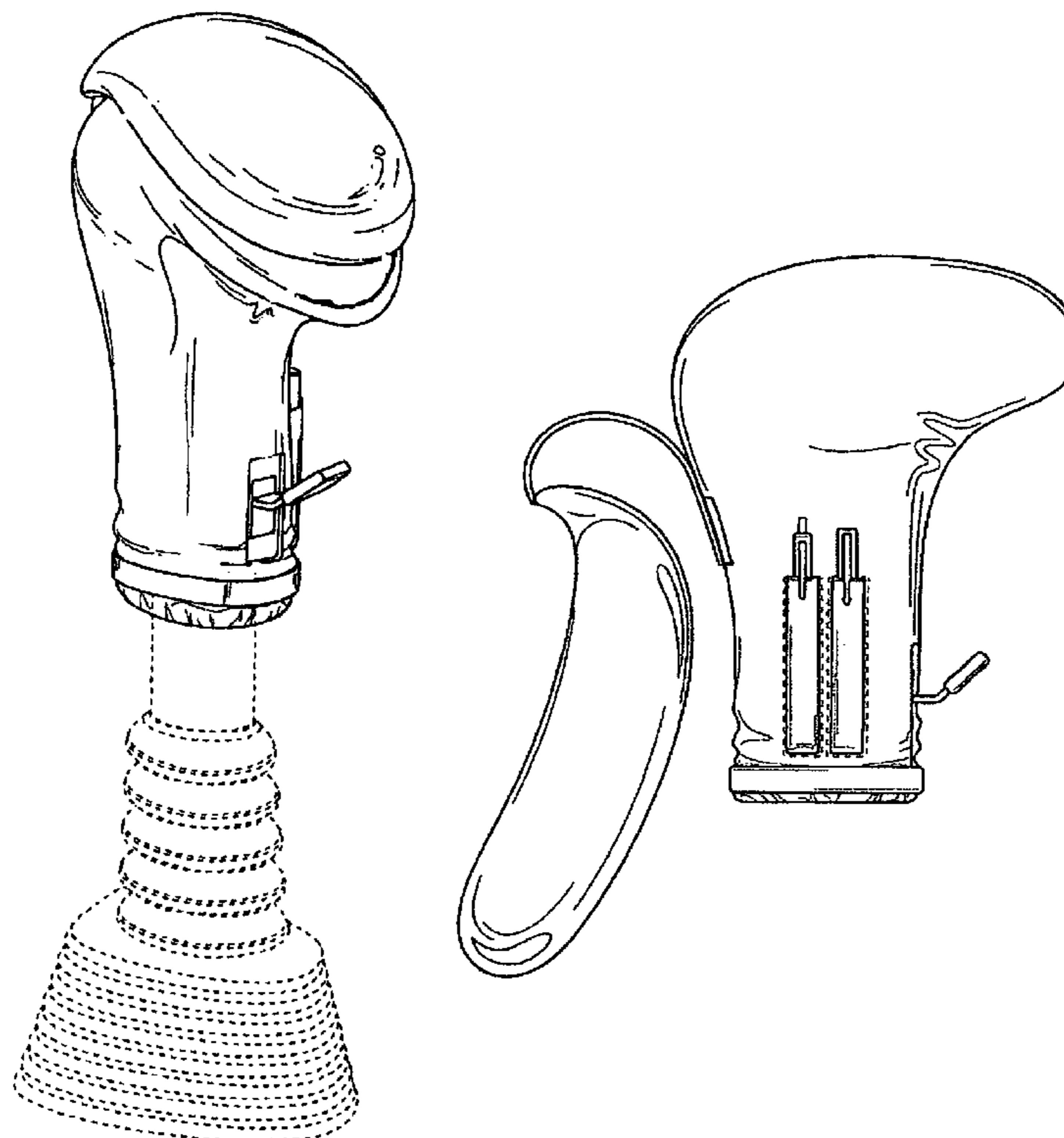

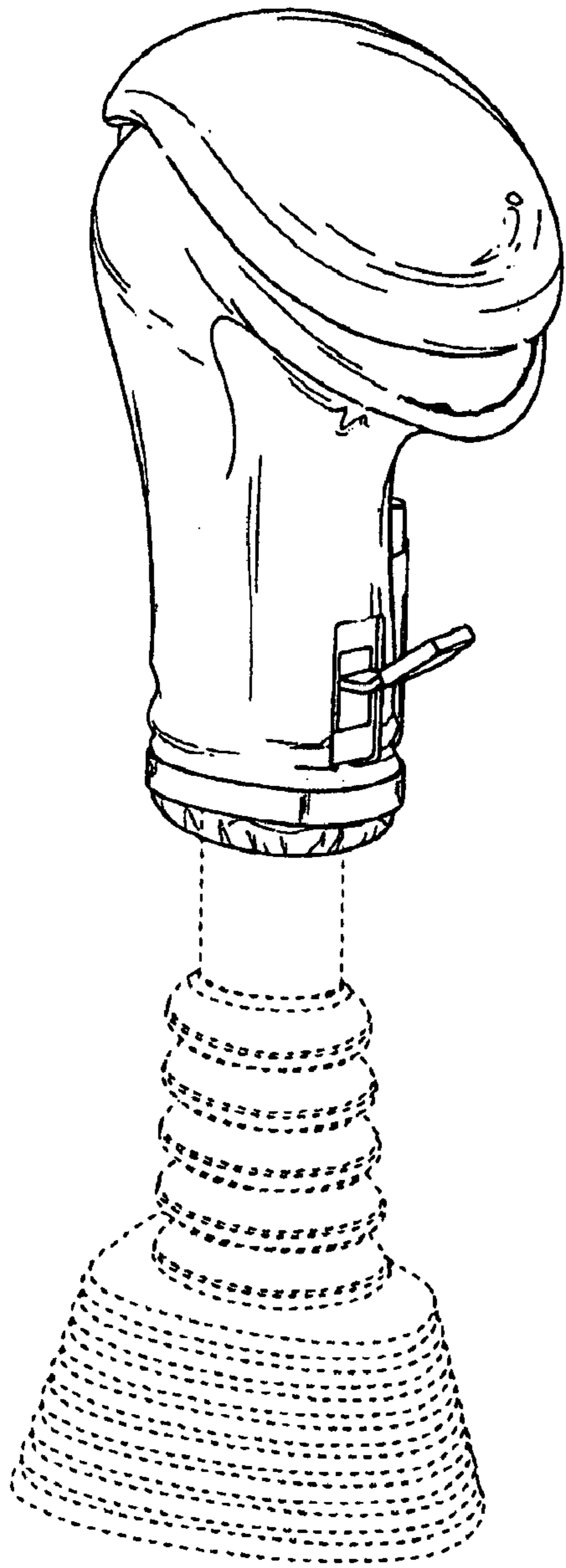

FIG. 1

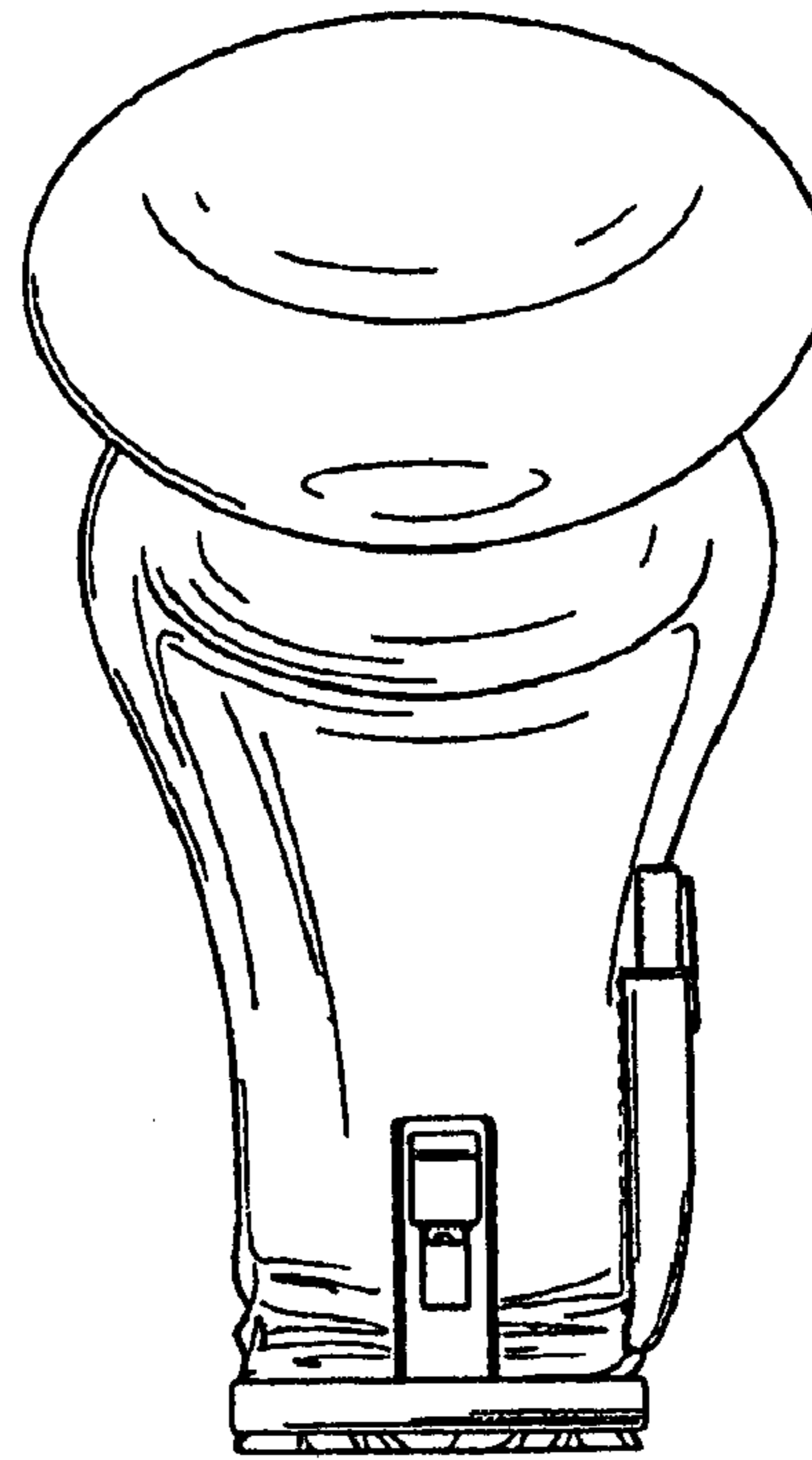

FIG. 2

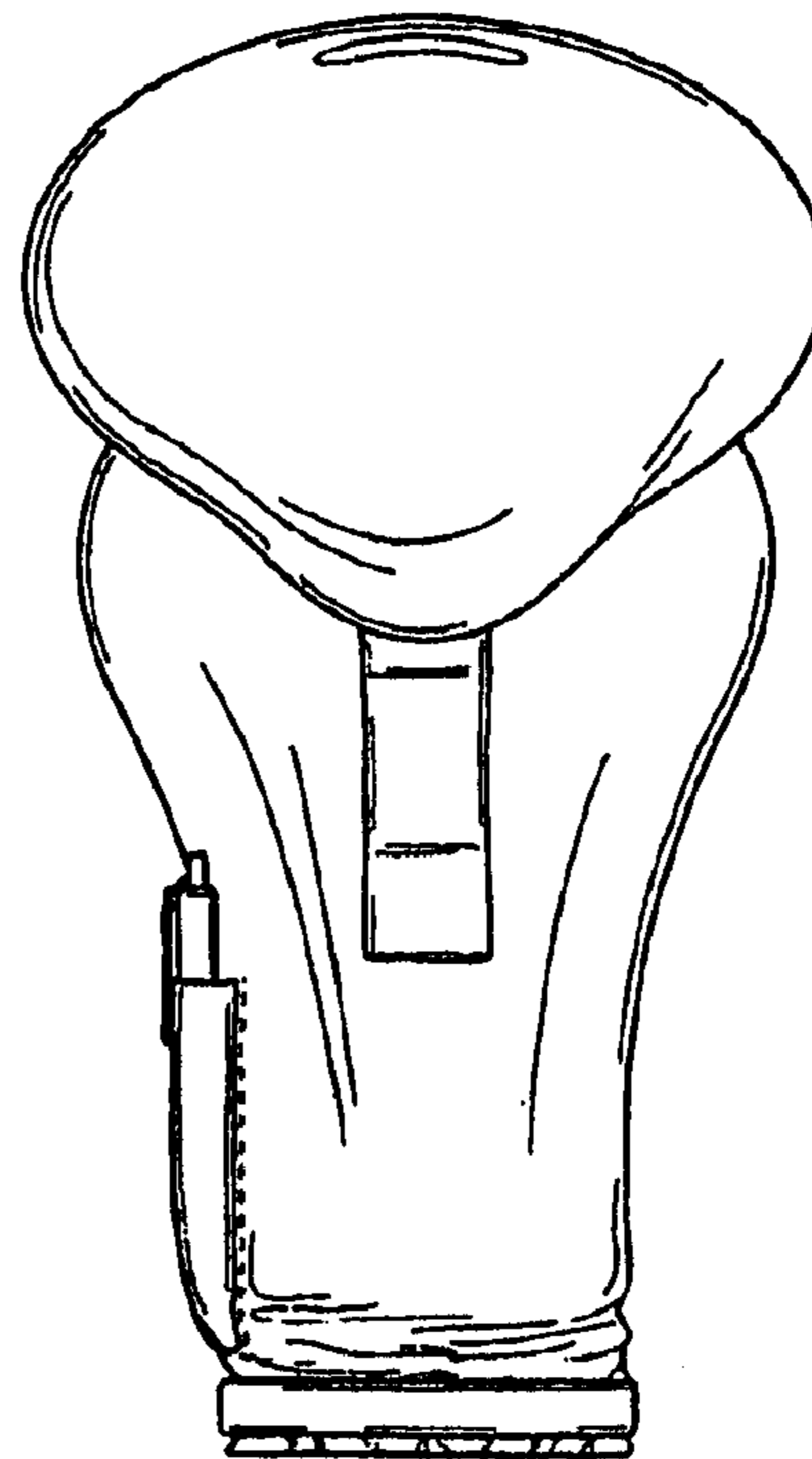

FIG. 3

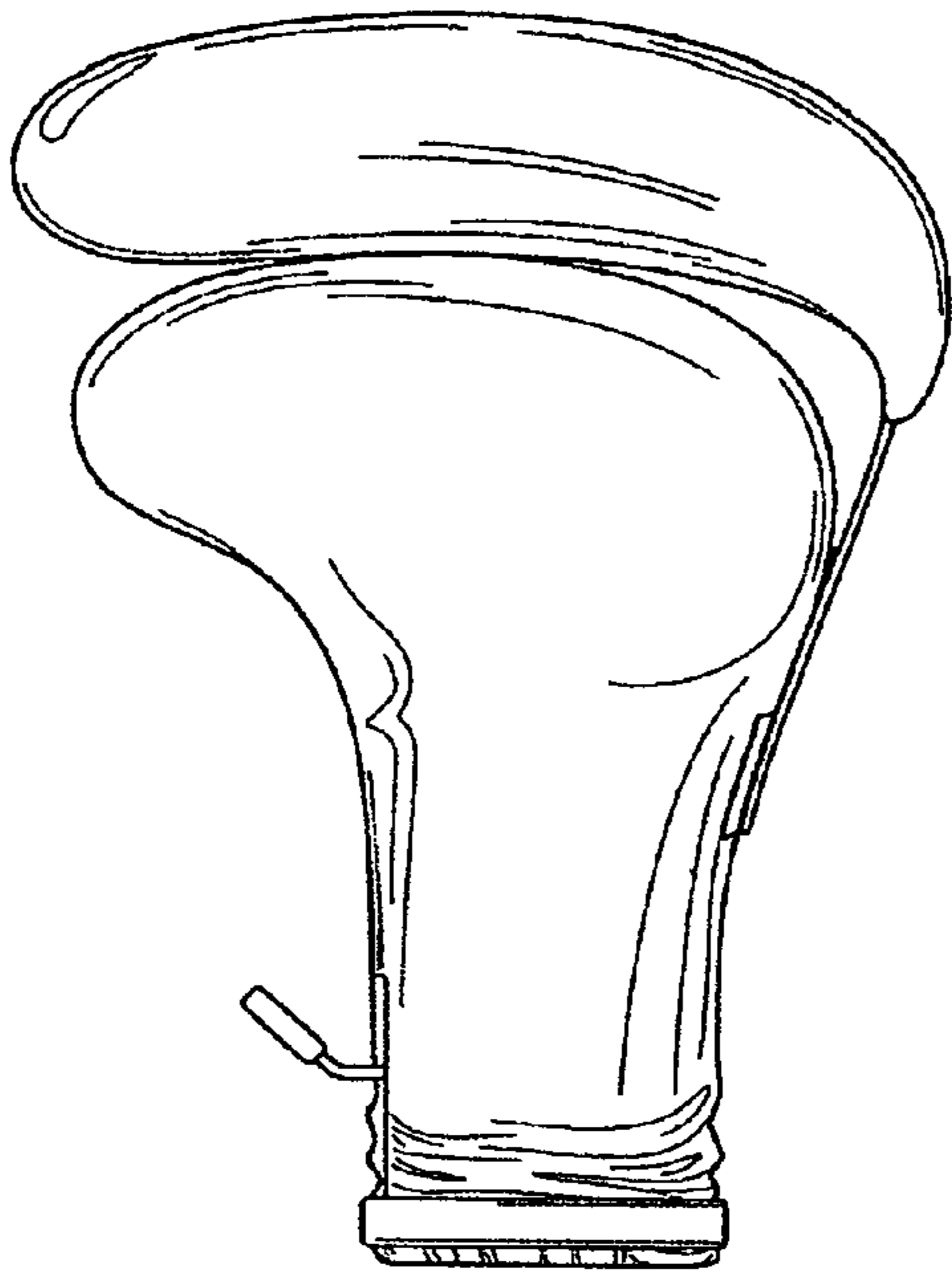

FIG. 4

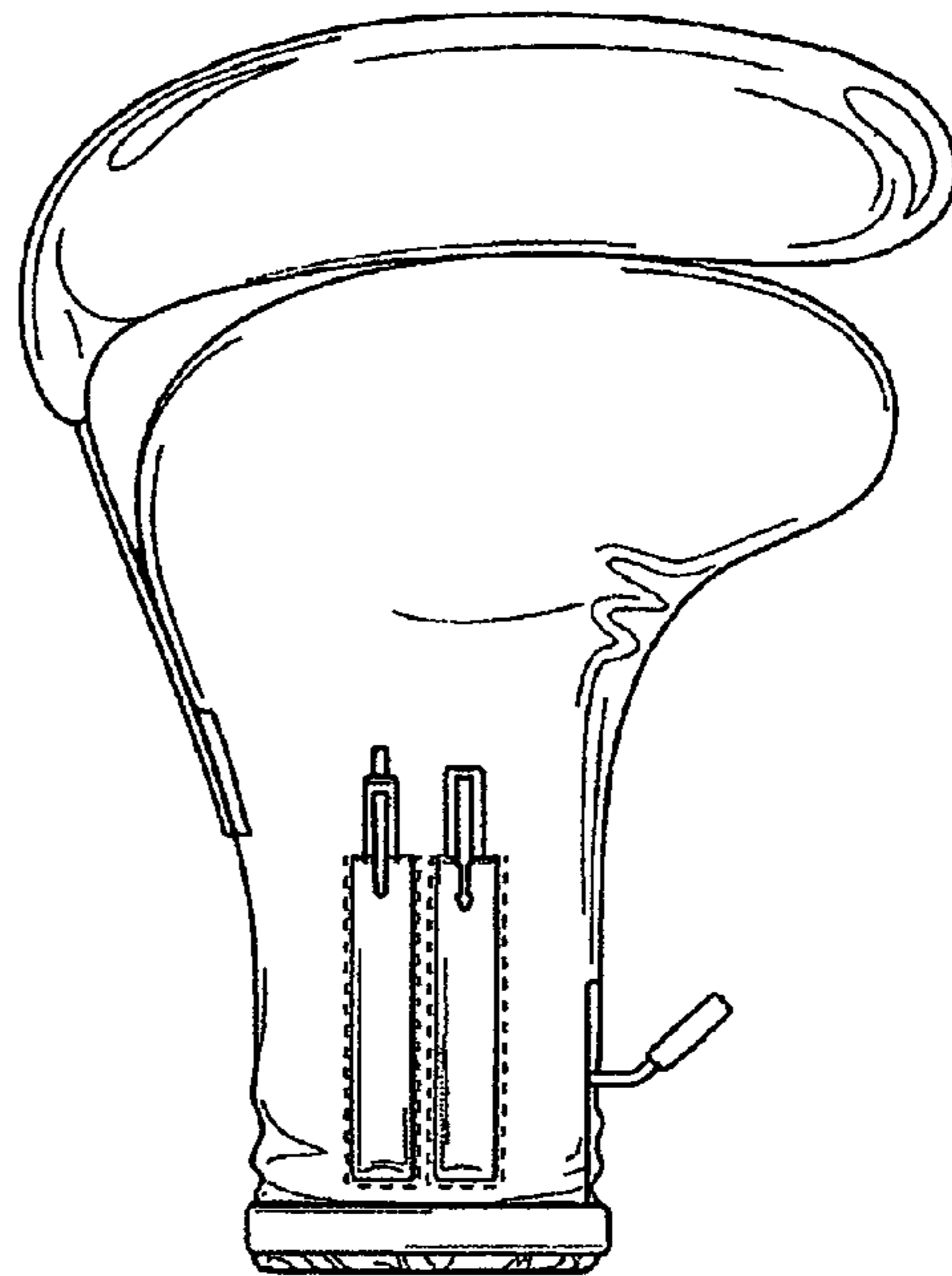

FIG. 5

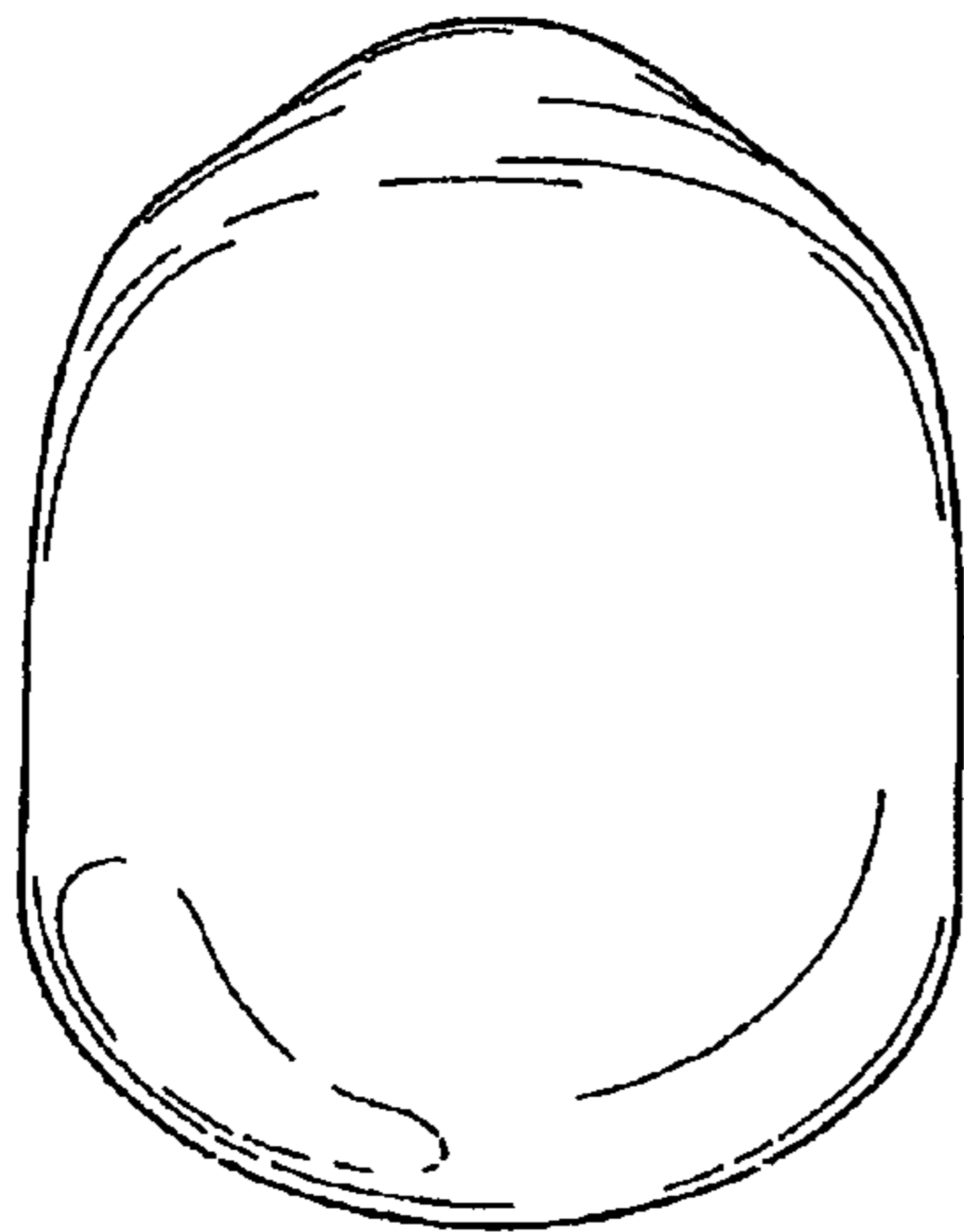

FIG. 6

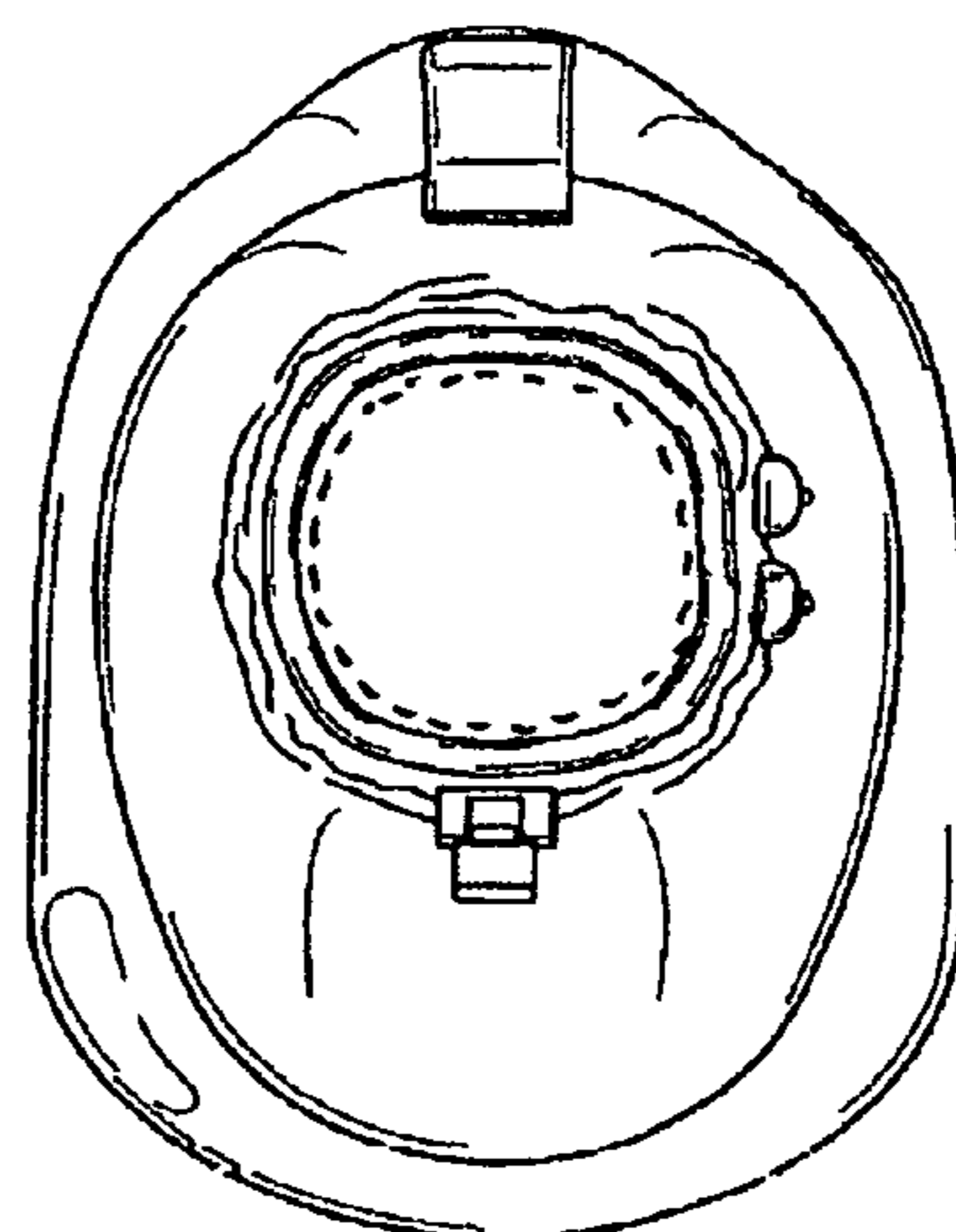

FIG. 7

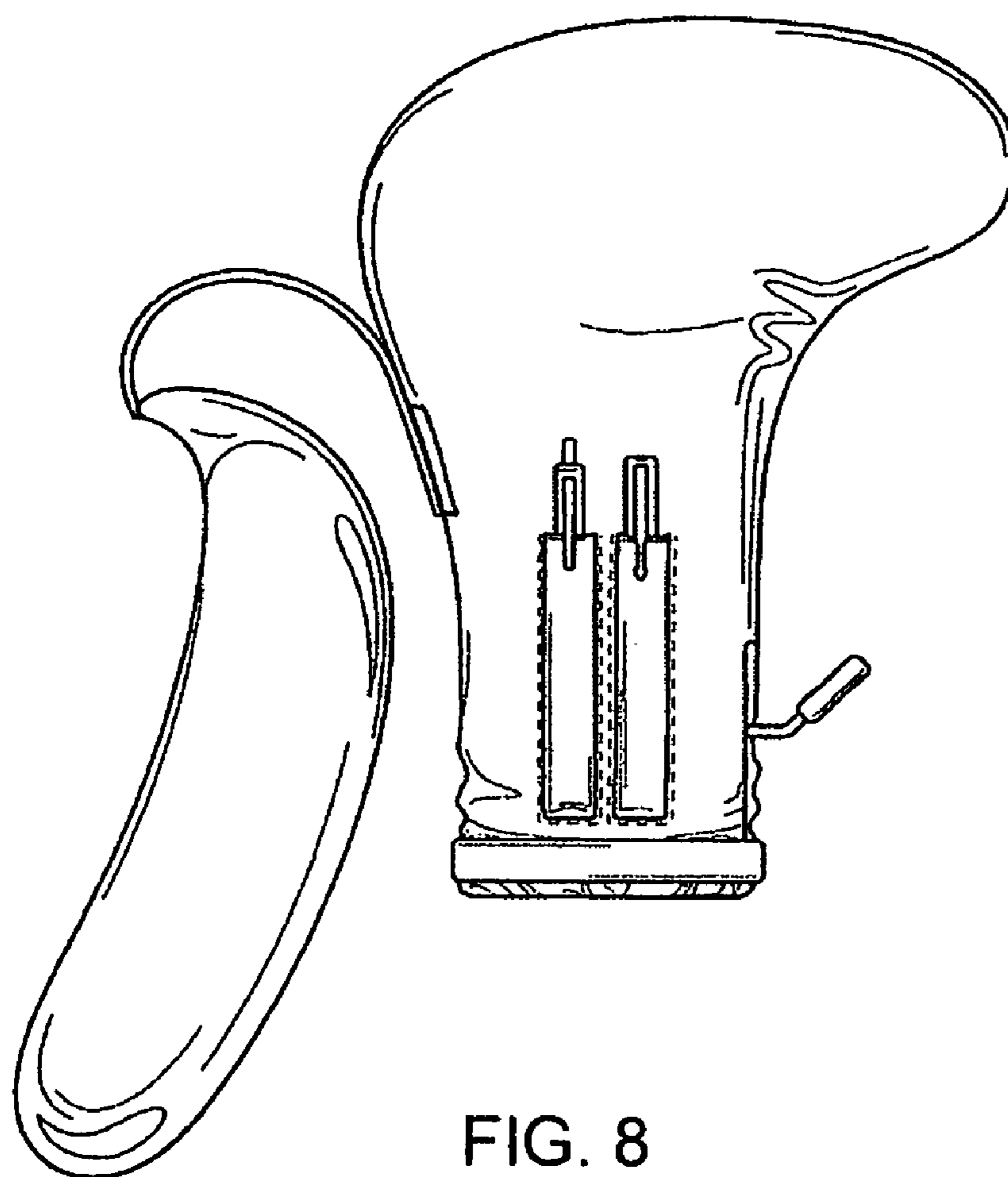

FIG. 8