

US00D606907S

(12) **United States Design Patent**
Arai et al.

(10) **Patent No.:** **US D606,907 S**
(45) **Date of Patent:** **** Dec. 29, 2009**

(54) **MOTORCYCLE OR MOTORCYCLE
REPLICA**

(75) Inventors: **Takashi Arai**, Wako (JP); **Takahiro
Asakawa**, Wako (JP)

(73) Assignee: **Honda Motor Co., Ltd.**, Tokyo (JP)

(**) Term: **14 Years**

(21) Appl. No.: **29/334,241**

(22) Filed: **Mar. 23, 2009**

(30) **Foreign Application Priority Data**

Sep. 24, 2008 (JP) 2008-024425

(51) **LOC (9) Cl.** **12-11**

(52) **U.S. Cl.** **D12/110**

(58) **Field of Classification Search** D12/110,
D12/218, 186; 180/219, 220, 69.4; 280/833-835;
D6/354; 297/195.1, 188.01, 217.1

See application file for complete search history.

(56) **References Cited**

U.S. PATENT DOCUMENTS

D288,796 S * 3/1987 Nakano et al. D12/110

D516,468 S * 3/2006 Kuboshima et al. D12/110

D531,090 S * 10/2006 Iimura D12/110
D559,738 S * 1/2008 Takigawa et al. D12/110

* cited by examiner

Primary Examiner—Cathron C Brooks

Assistant Examiner—Linda G. Brooks

(74) *Attorney, Agent, or Firm*—Birch, Stewart, Kolasch &
Birch, LLP

(57) **CLAIM**

The ornamental design for, motorcycle or motorcycle replica,
as shown and described.

DESCRIPTION

FIG. 1 is a front and right side perspective view of motorcycle
or motorcycle replica, showing our new design;

FIG. 2 is a rear and left side perspective view thereof;

FIG. 3 is a front elevation view thereof;

FIG. 4 is a rear elevation view thereof;

FIG. 5 is a top plan view thereof;

FIG. 6 is a right side elevation view thereof; and,

FIG. 7 is a left side elevation view thereof.

The broken lines illustrate portions of the motorcycle or
motorcycle replica that form no part of the claimed design.

1 Claim, 7 Drawing Sheets

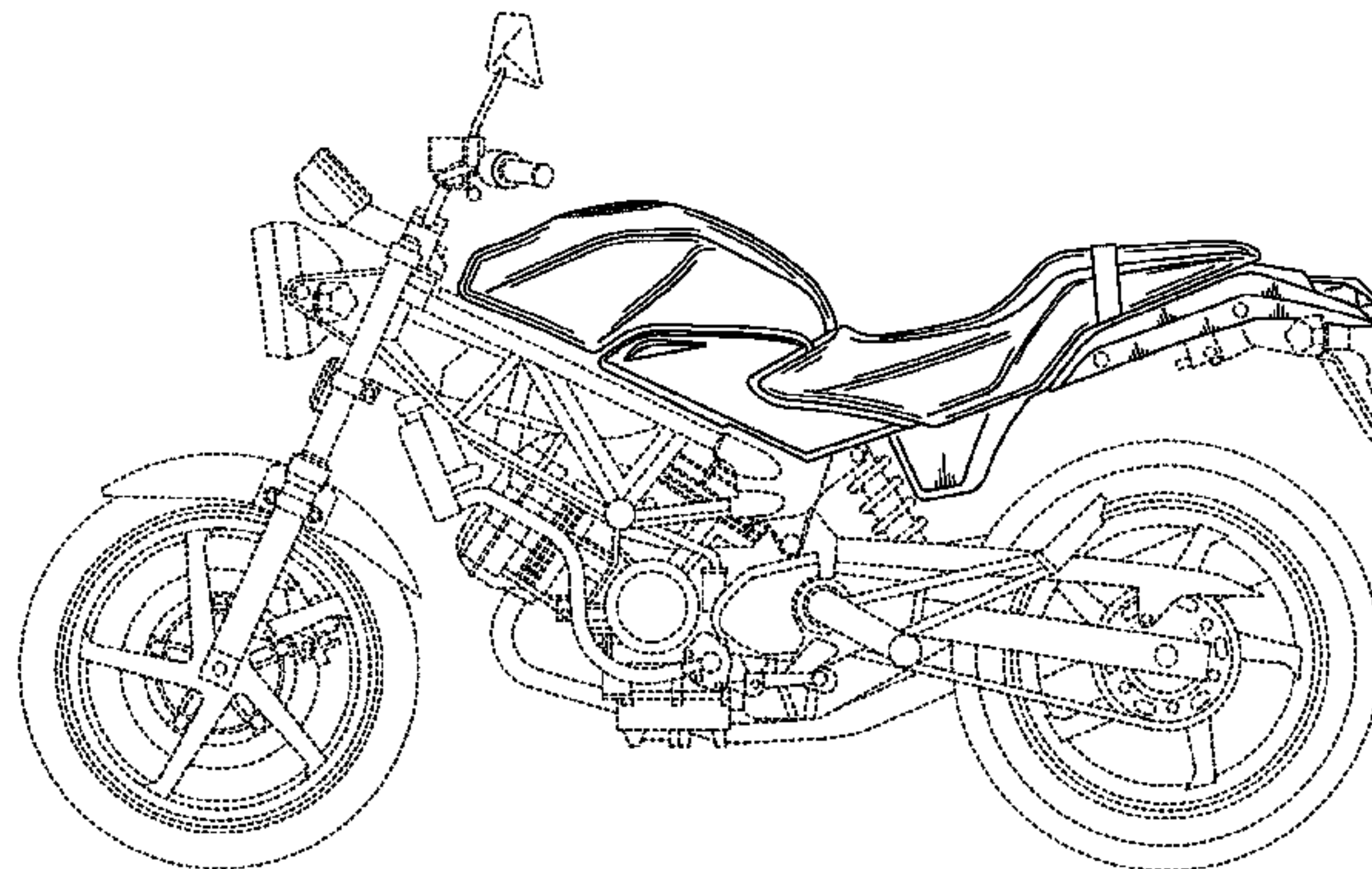
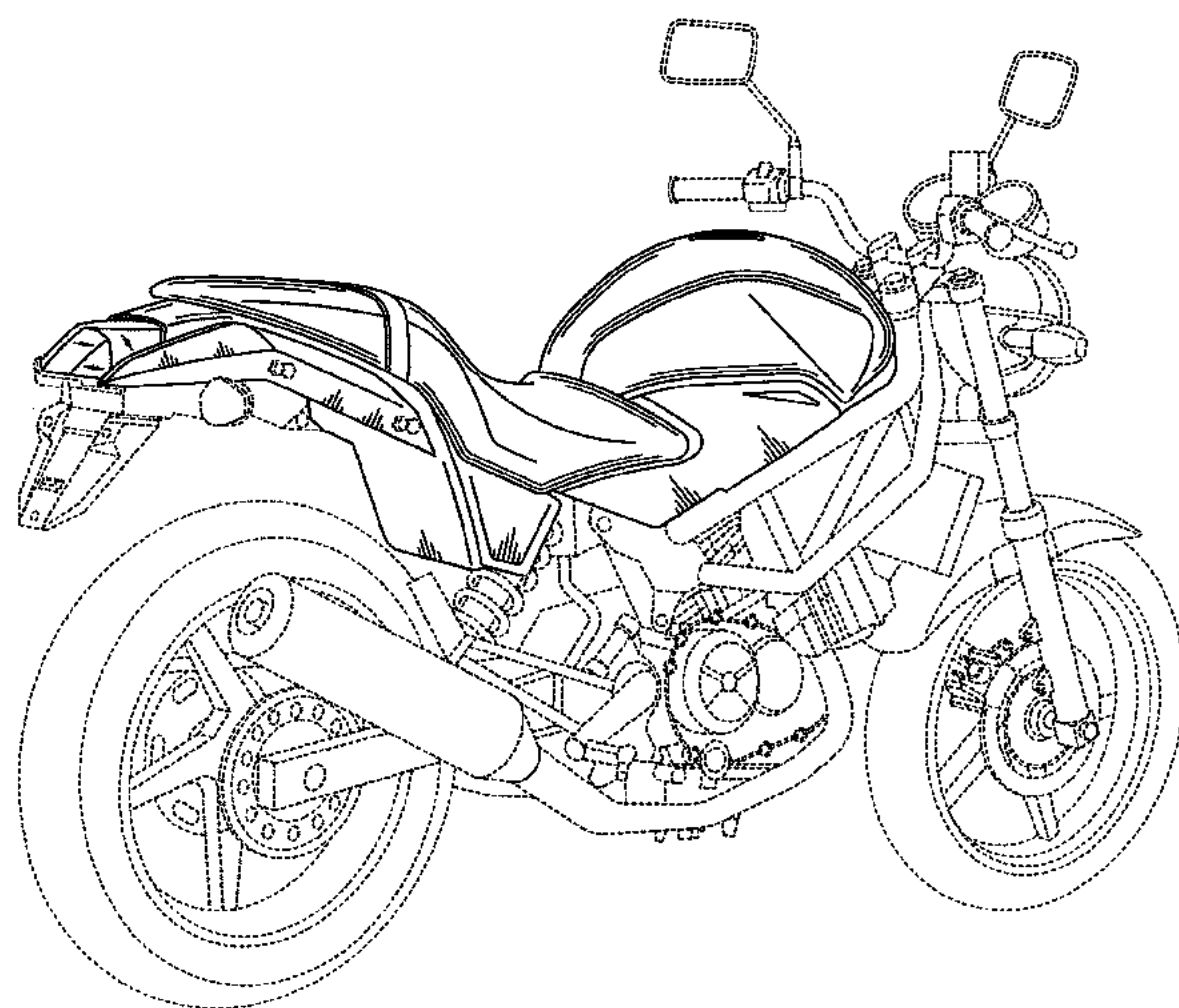

Fig. 1

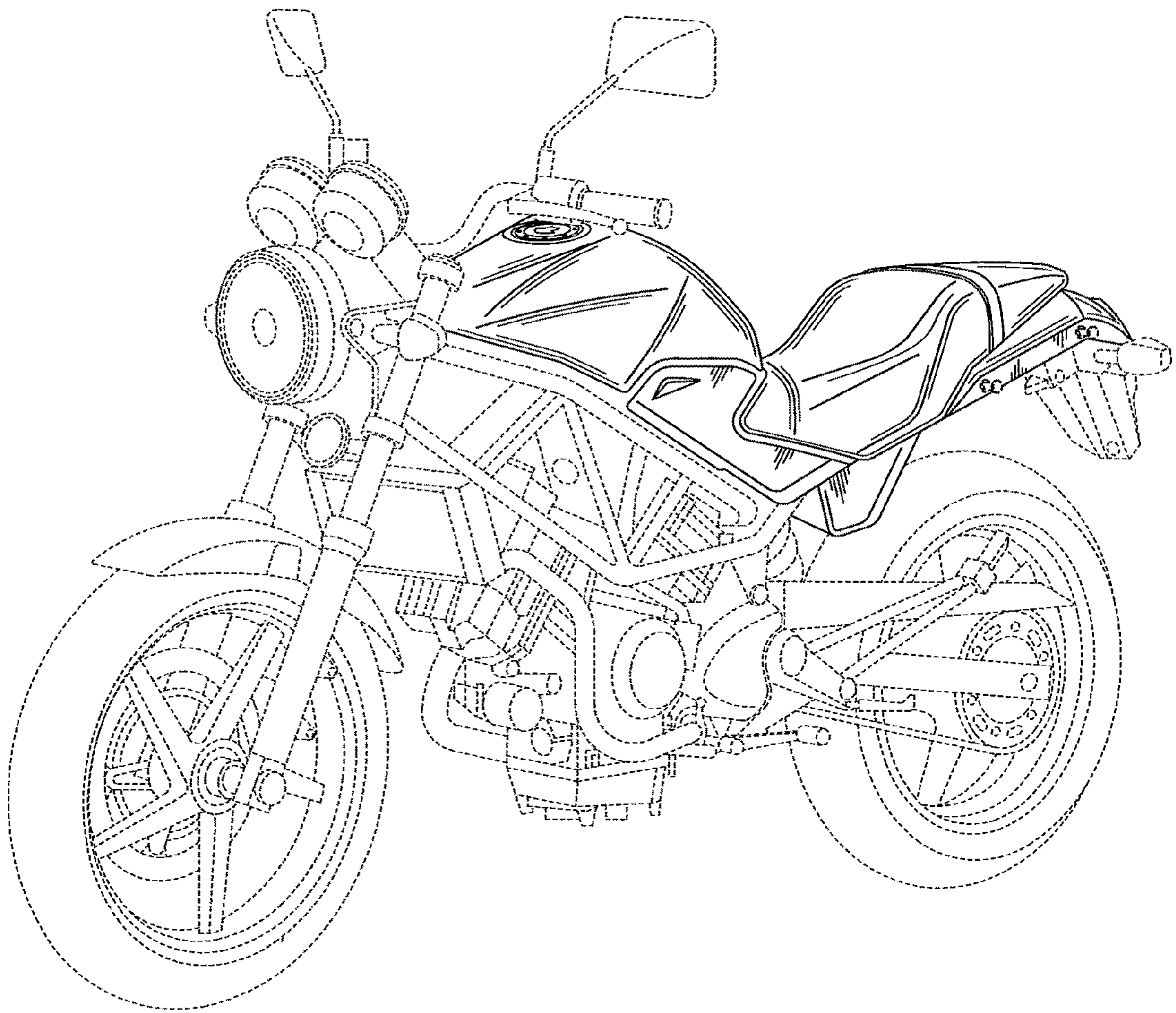

Fig. 2

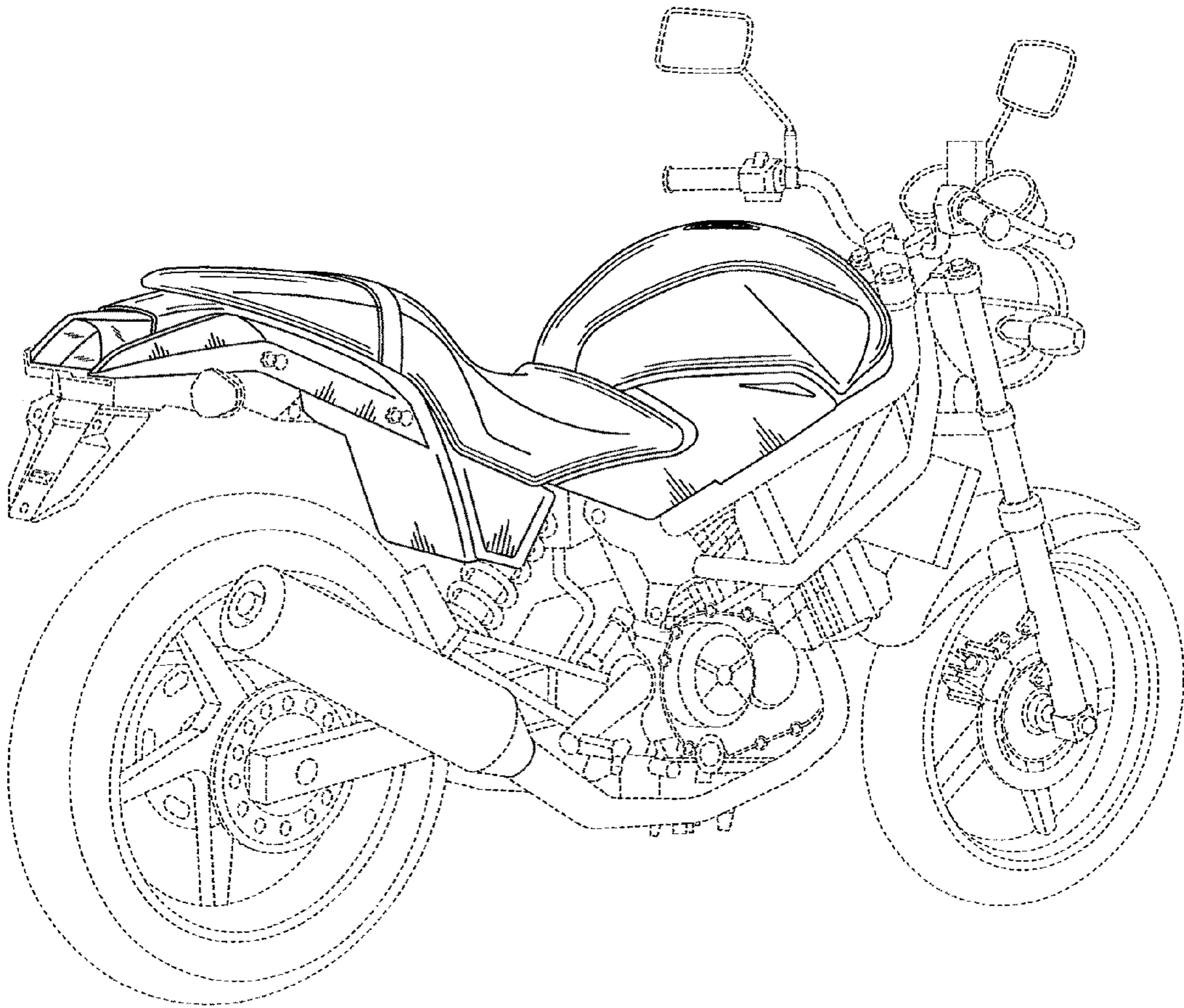

Fig. 3

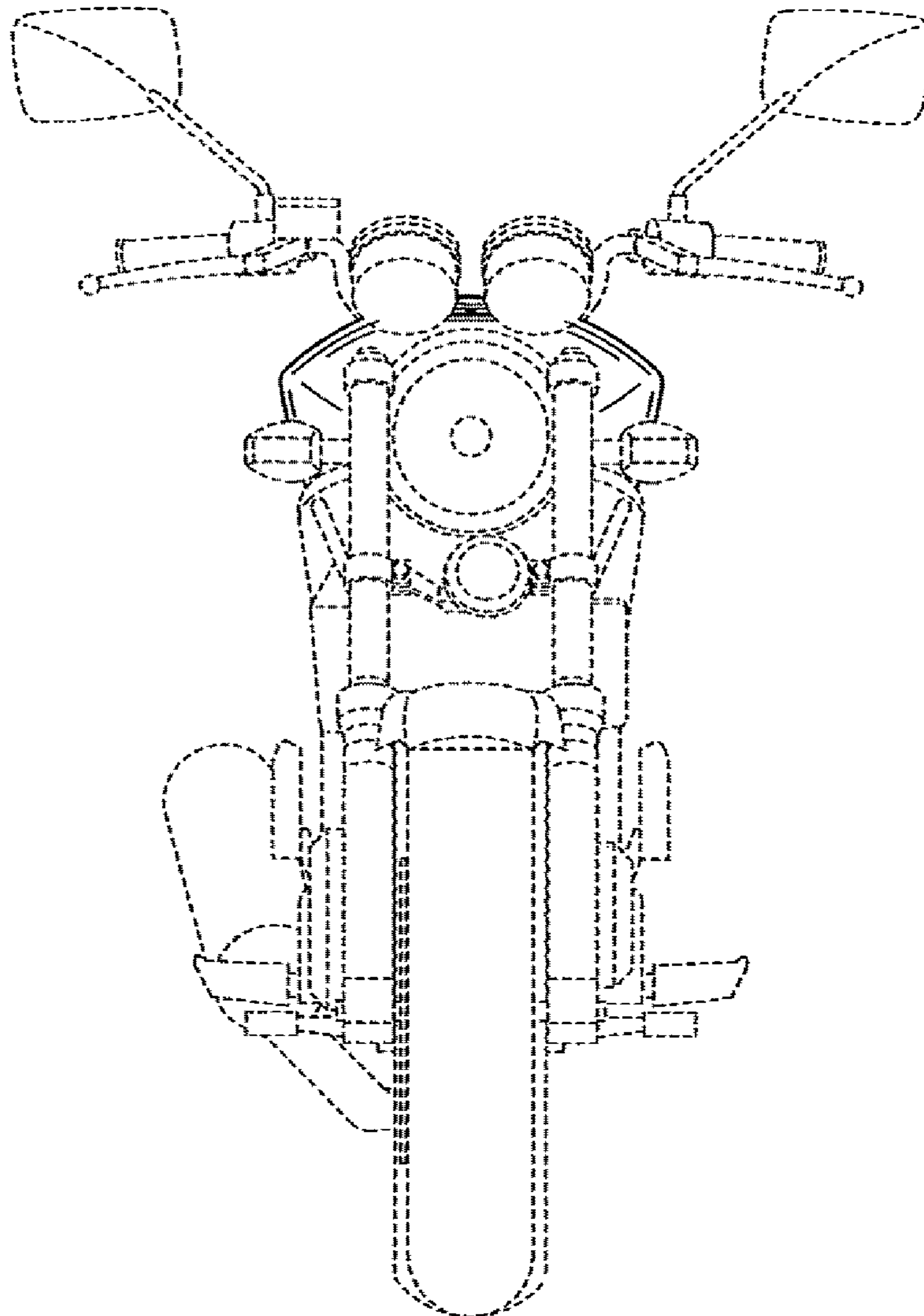

Fig. 4

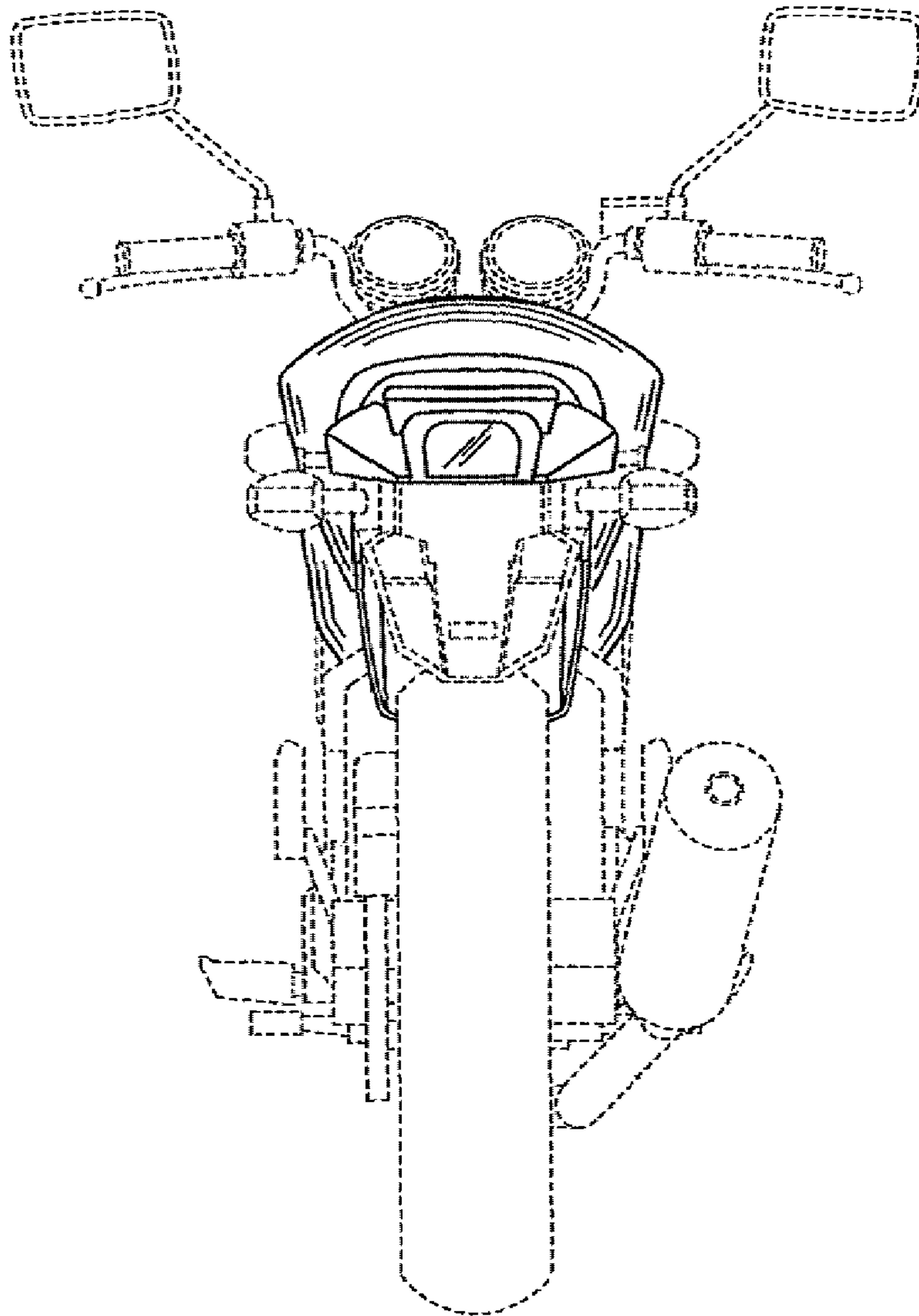

Fig. 5

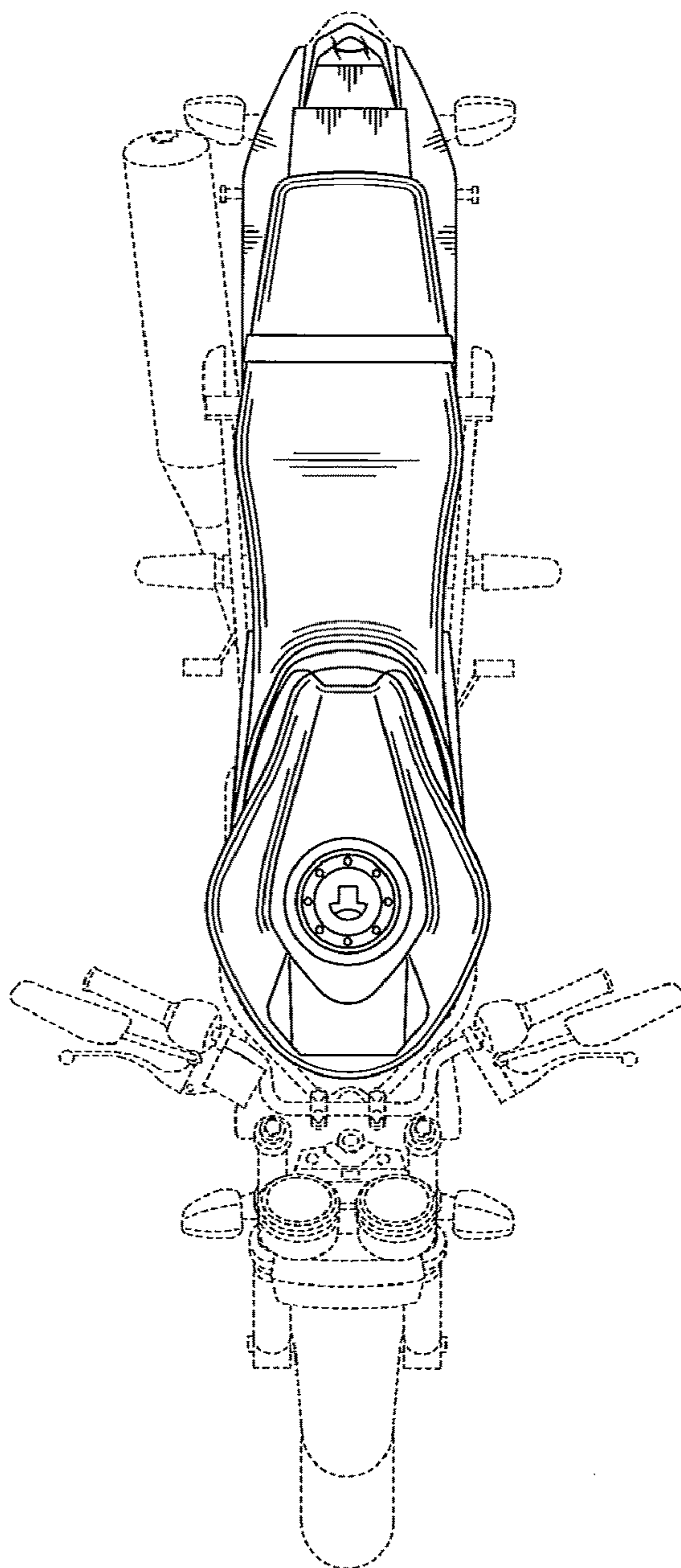

Fig.6

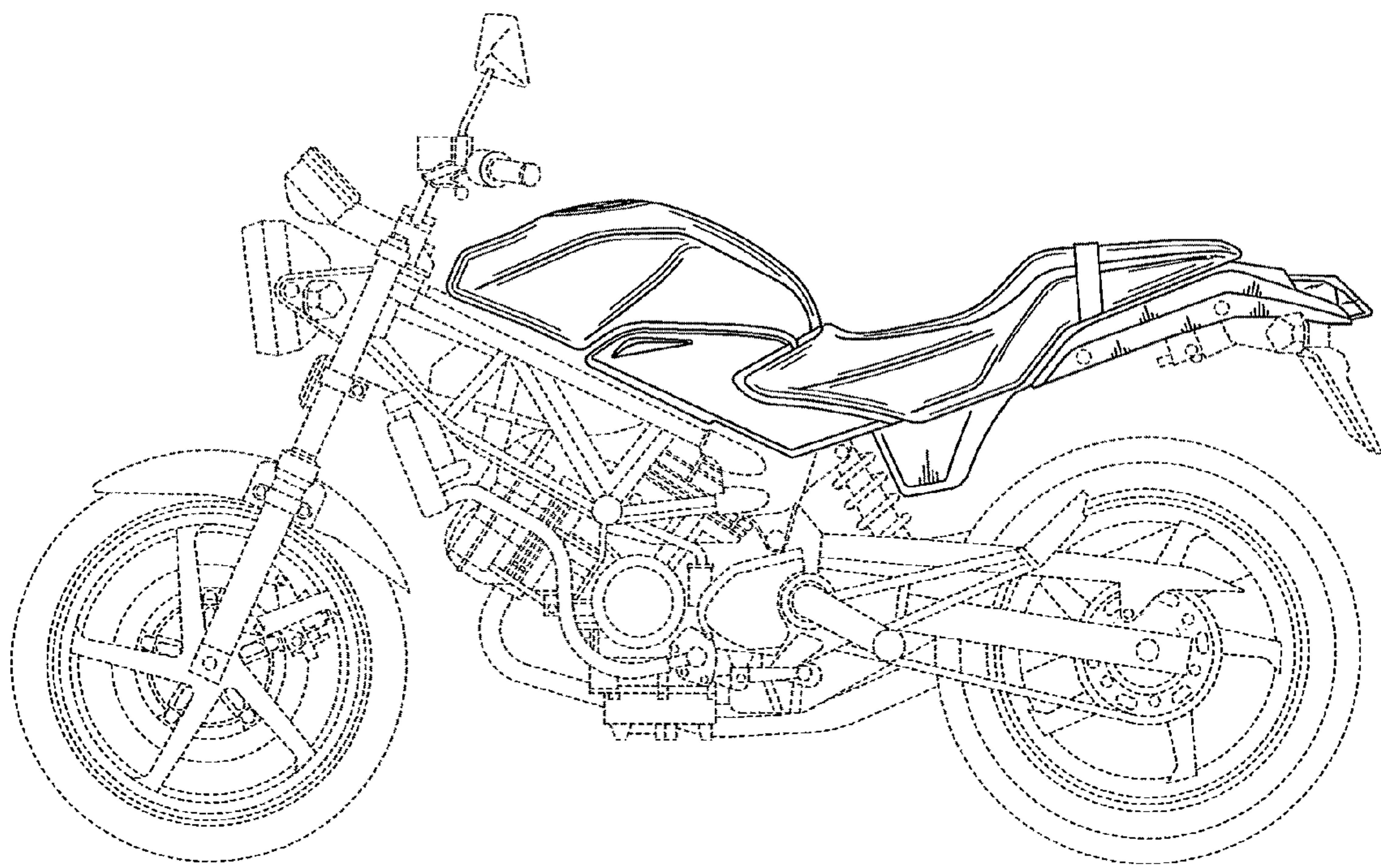

Fig. 7

